

**Items you will need to provide for assembly:**  
**Articles que vous devrez fournir pour le montage:**  
**Elementos que necesitará para el montaje:**

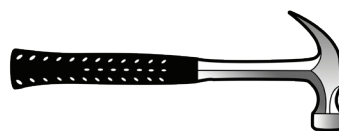

# PARTS | PIÈCES | PIEZAS

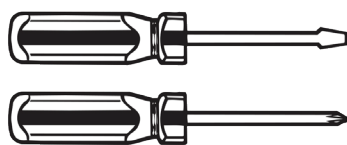
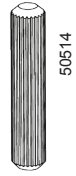

x14

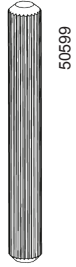

x6

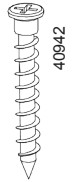

x18



x20



x11

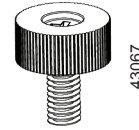

x5



x2



x1

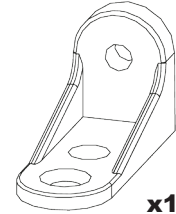

x1

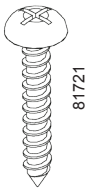

x1

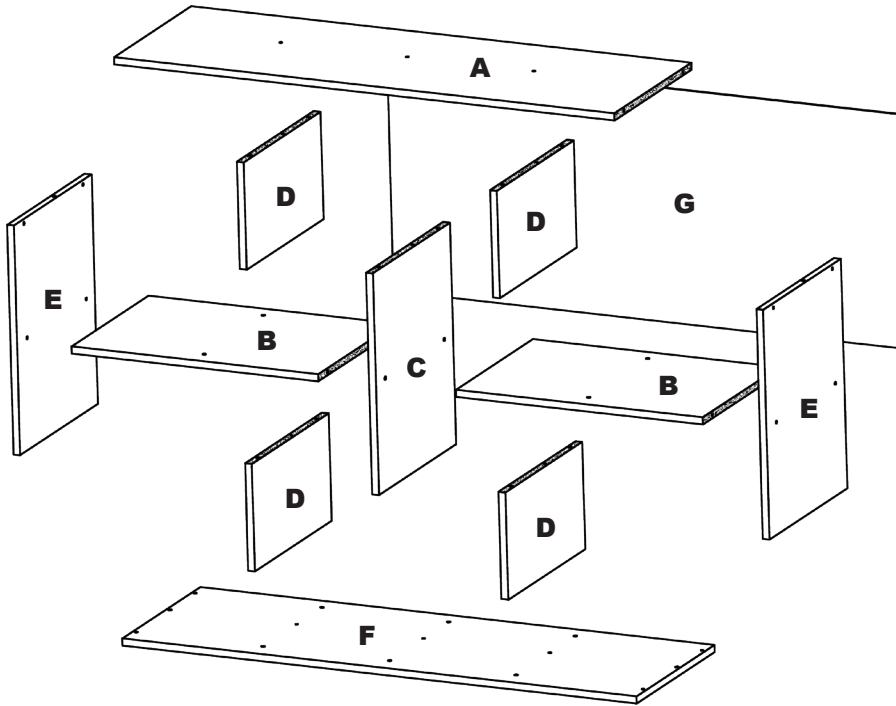

- A** x1
- B** x2
- C** x1
- D** x4
- E** x2
- F** x1
- G** X1

To ease part identification, all laminate parts are labeled. Locate sticker or a “stamp” on an unfinished edge to identify parts.

To further ease assembly, all unfinished edges/sides are shown as a shaded pattern throughout each assembly step.

Pour faciliter l'identification des pièces, toutes les pièces stratifiées sont étiquetées. Localiser un autocollant ou une estampe servant à identifier les pièces sur une bordure brute.

Pour faciliter encore une fois le montage, toutes les bordures et surfaces brutes sont présentées en « gris » à chaque étape du processus de montage. Pour identifier les pièces plus

fácilmente, todas las piezas laminadas tienen una etiqueta. Ubique la pegatina o el “sello” en el borde sin acabar para identificar las piezas.

Para facilitar aún más el ensamblaje, todos los bordes / lados sin acabar están sombreados de color “gris” en todos los pasos del ensamblaje.



## SAFETY PRECAUTIONS | CONSIGNES DE SÉCURITÉ | PRECAUCIONES DE SEGURIDAD



### WARNING

- This unit contains small parts which could be a choking hazard for small children. Children should be under adult supervision at all times or serious injury could occur.
- Always unload unit prior to moving the unit. The weight of personal belongings can cause the unit to become unstable and either tip or collapse. Serious bodily injury and/or damage to personal belongings may occur.
- Do not overload unit. If any shelf, top, or bottom of unit bows or bends, it is overloaded. The shelf, top, or bottom could collapse and cause serious bodily injury and/or damage to personal belongings.
- Do not climb or step on the unit. The unit may become unstable and either tip or collapse. Serious bodily injury and/or damage to personal belongings may occur.
- Follow proper safety procedures when using power tools and ladders (when applicable).
- **FOR FLOOR USE ONLY. NOT INTENDED FOR USE ON SHELF**



### MISE EN GARDE

- Cette unité contient des petites pièces qui représentent un risque d'étouffement pour les jeunes enfants. Les enfants doivent être sous la supervision d'un adulte en tout temps afin d'éviter les blessures graves.
- Veuillez toujours vider l'unité avant de la déplacer. Le poids des biens personnels peut déstabiliser l'unité, la faisant basculer ou se renverser. Cela pourrait causer des blessures corporelles graves ou endommager les effets personnels.
- Ne surchargez pas l'unité. Si une des tablettes de l'unité courbe ou plie, elle est trop chargée. La tablette du milieu, le haut ou le bas de l'unité pourrait s'effondrer et causer de graves blessures corporelles ou endommager les effets personnels.
- Ne grimpez pas ou ne montez pas sur l'unité. L'unité peut devenir instable et risque de basculer ou de se renverser. Cela pourrait causer des blessures corporelles graves ou endommager les effets personnels.
- Suivez les procédures de sécurité lors de l'utilisation d'outils et d'échelles (lorsque nécessaire).
- **POUR UTILISER AU SOL SEULEMENT. NON DESTINÉ À ÊTRE UTILISÉ SUR UNE ÉTAGÈRE.**



### ADVERTENCIA

- Esta unidad contiene partes pequeñas que podrían resultar peligrosas y causar asfixia en niños pequeños. Los niños deben permanecer bajo la supervisión de un adulto en todo momento para evitar lesiones graves.
- Descargue la unidad siempre antes de desplazarla. El peso de sus pertenencias puede hacer que la unidad se vuelva inestable y se incline o se caiga, pudiendo causar lesiones corporales graves o dañar sus pertenencias.
- No sobrecargue la unidad. Si alguna estantería, la parte superior o la parte inferior de la unidad se comban o se doblan, entonces están sobrecargadas. La estantería, la parte superior o la parte inferior podrían caerse y causar lesiones corporales graves o dañar sus pertenencias.
- No trepe ni se suba a la unidad, tampoco la pise. Esta podría volverse inestable e inclinarse o caerse, pudiendo causar lesiones corporales graves o dañar sus pertenencias.
- Siga los procedimientos de seguridad adecuados cuando utilice herramientas eléctricas y escaleras (si corresponde).
- **PARA UTILIZARSE ÚNICAMENTE EN EL SUELO. NO HA SIDO DISEÑADO PARA UTILIZARSE EN ESTANTERÍAS**

# HELPFUL HINTS | CONSEILS UTILES | CONSEJOS PRÁCTICOS

Use "PART IDENTIFICATION" and exploded view to identify parts!

Utiliser l'« IDENTIFICATION DES PIÈCES » et le schéma éclaté pour identifier les pièces!

¡Use la "IDENTIFICACIÓN DE LAS PIEZAS" y la perspectiva ampliada para identificar las piezas!

- Note overall shape of part.
- Remarquer la forme générale de chaque pièce.
- Vea la forma de las piezas en general.

- Count and locate holes in each part.
- Compter et localiser les trous de chaque pièce.
- Cuente y ubique los agujeros de cada pieza.

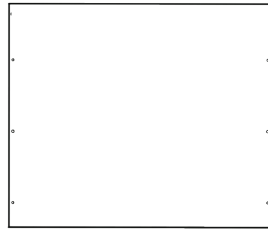

FINISHED EDGE | BORDURE OUVRÉE | BORDE ACABADO



UNFINISHED EDGE | BORDURE BRUTE | BORDE SIN ACABAR



CORRECT | ADÉQUAT | CORRECTO

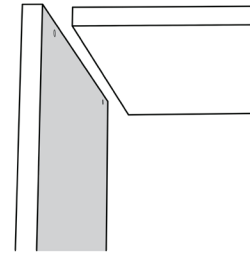

INCORRECT | INADÉQUAT  
INCORRECTO

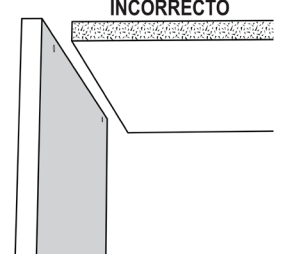

## DOWELS | GOUJONS | ESPIGAS

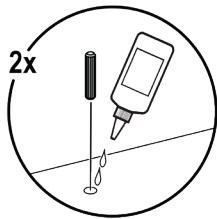

Place 1-2 drops of glue in each dowel hole.

Déposer 1 ou 2 gouttes de colle dans chaque trou de goujon.

Aplique de 1 a 2 gotas de pegamento en cada agujero de las espigas.



GLUE  
COLLE  
PEGAMENTO



We recommend you assemble on a soft surface to avoid damage to the unit or surface.



Nous vous recommandons de faire l'assemblage sur une surface lisse afin d'éviter d'endommager l'unité ou la surface.



Recomendamos realizar el ensamblaje sobre una superficie suave para evitar cualquier daño a la unidad o a la superficie.

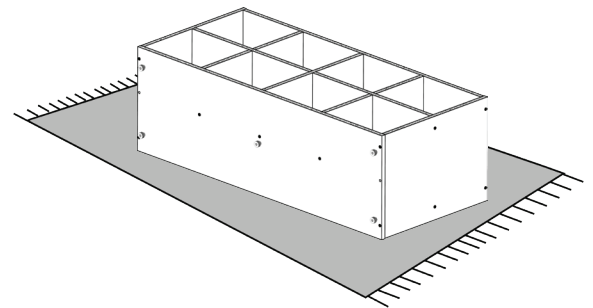

- We recommend you hand tighten screws. Use care not to over tighten if using power tools!
- Nous recommandons de resserrer les vis à la main. Prendre garde de ne pas trop serrer en utilisant des outils mécaniques.
- Recomendamos ajustar los tornillos de forma manual. Tenga cuidado de no ajustar demasiado si utiliza herramientas eléctricas.

**CLOSETMAID®**

# 1

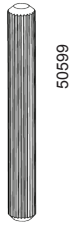

x2

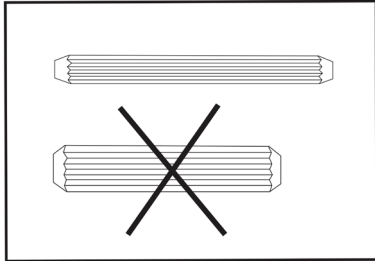

# 1)

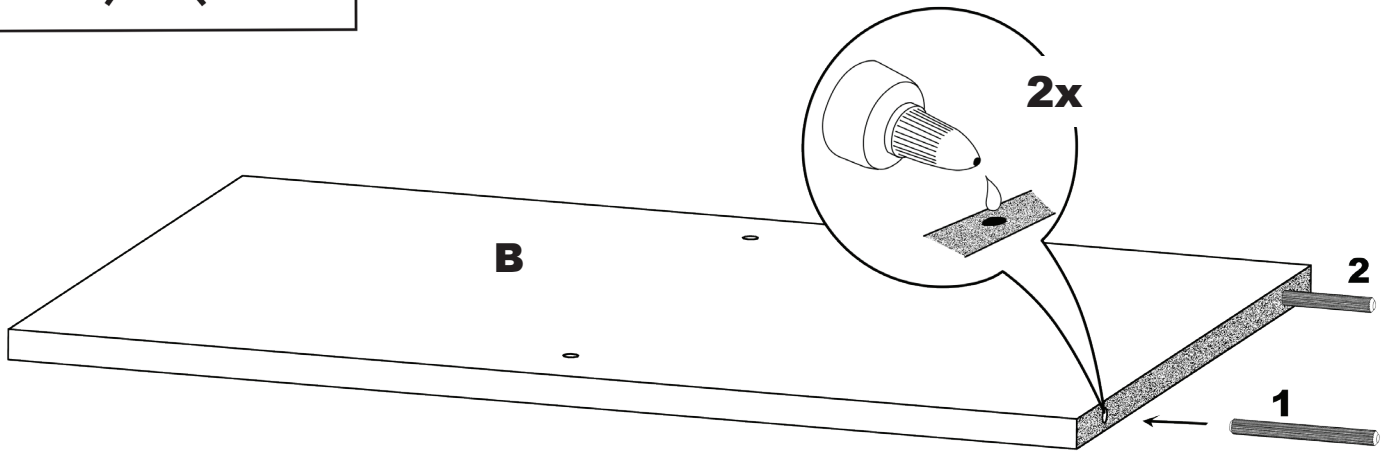

# 2)

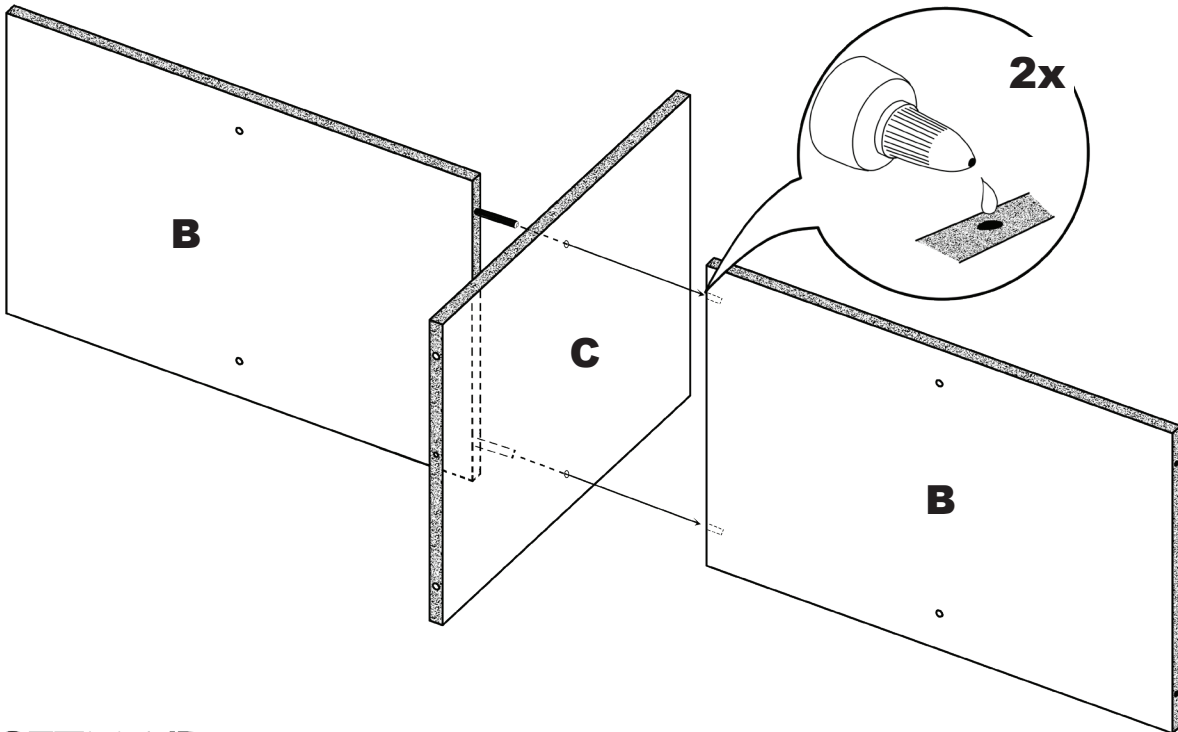

**CLOSETMAID**<sup>®</sup>

# 2

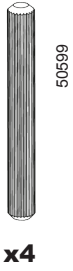

## 1)

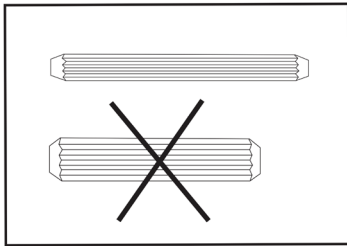
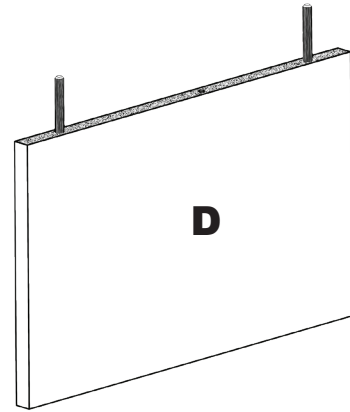
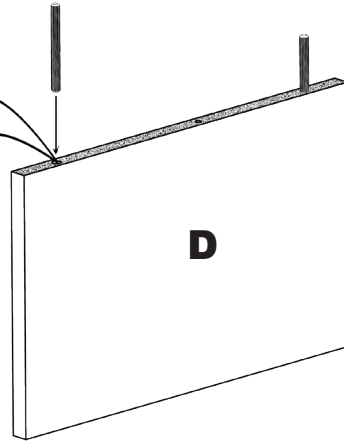
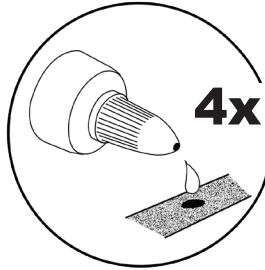

## 2)

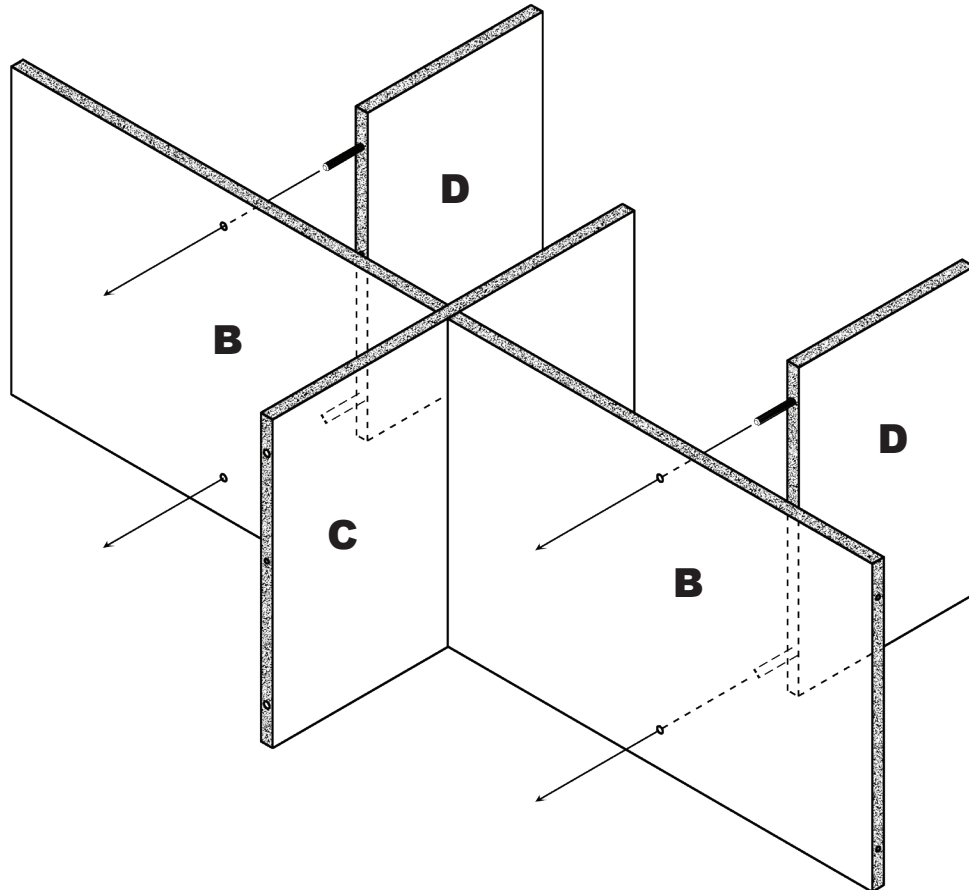

**CLOSETMAID®**

# 3

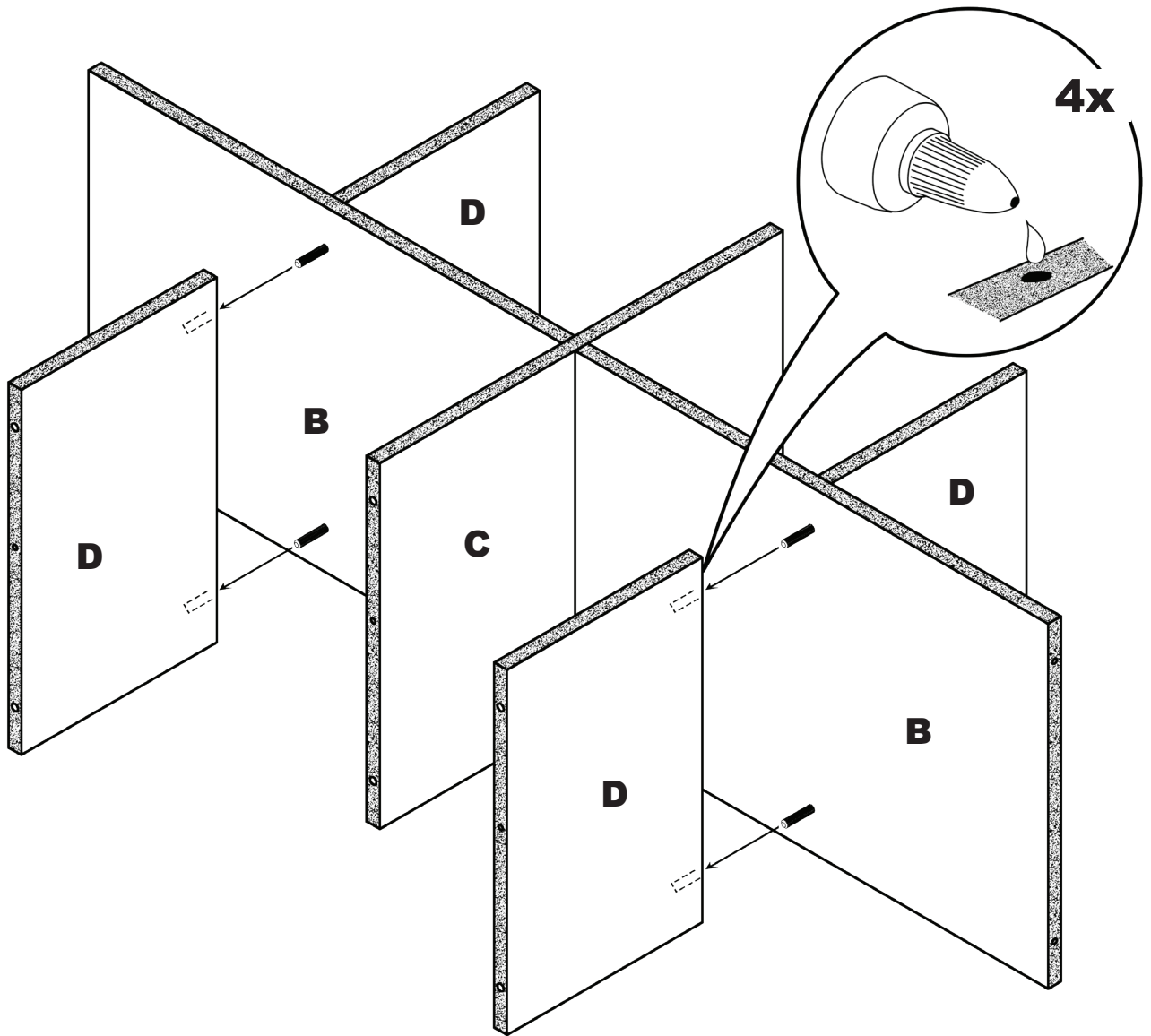

# 4

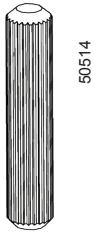

50514

x6



## 1)

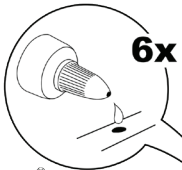

6x

**A**

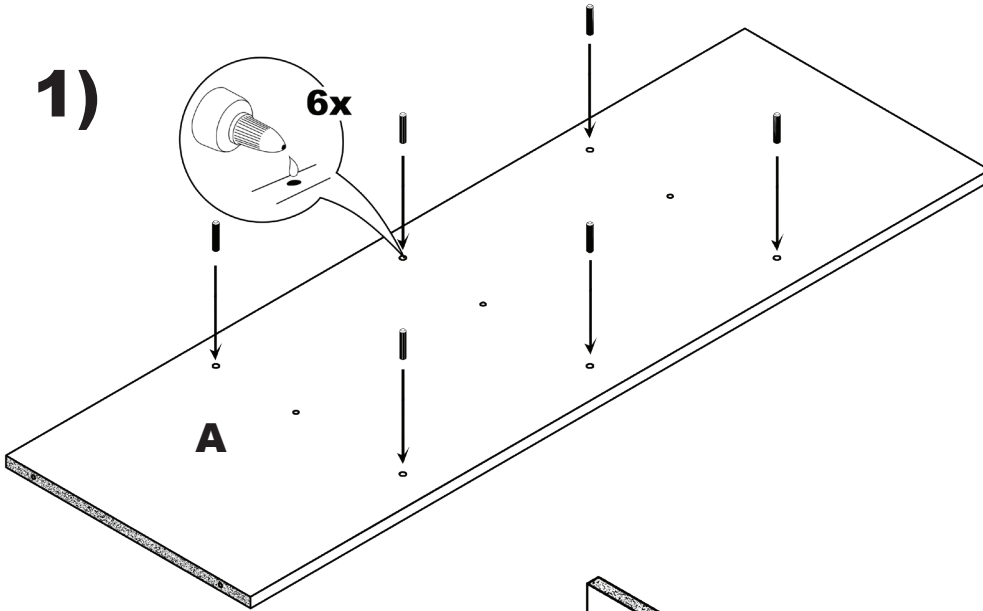

## 2)

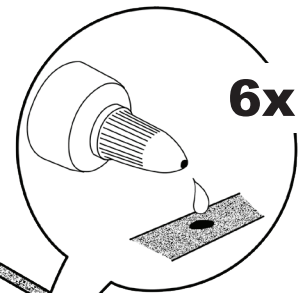

6x

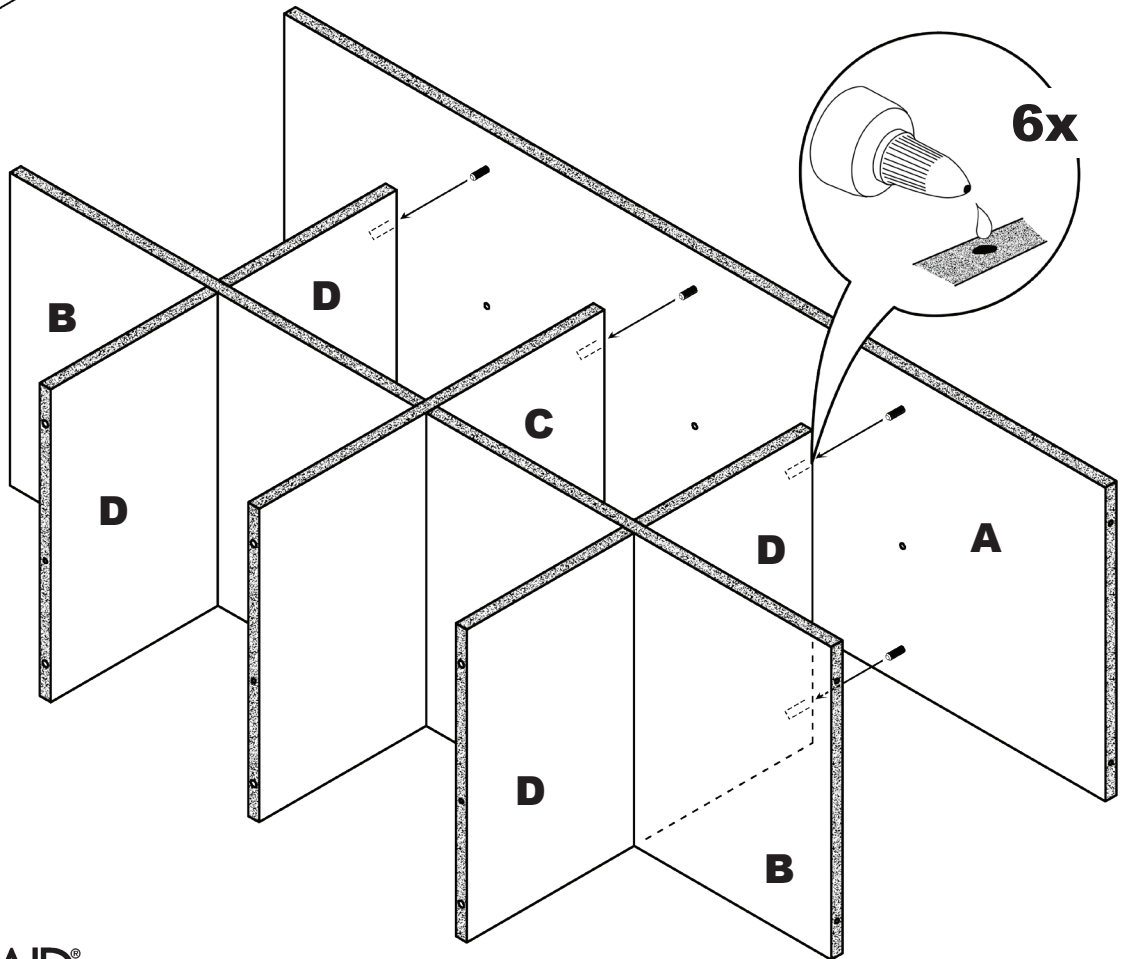

**CLOSETMAID**<sup>®</sup>

# 5

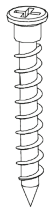

40942

x11

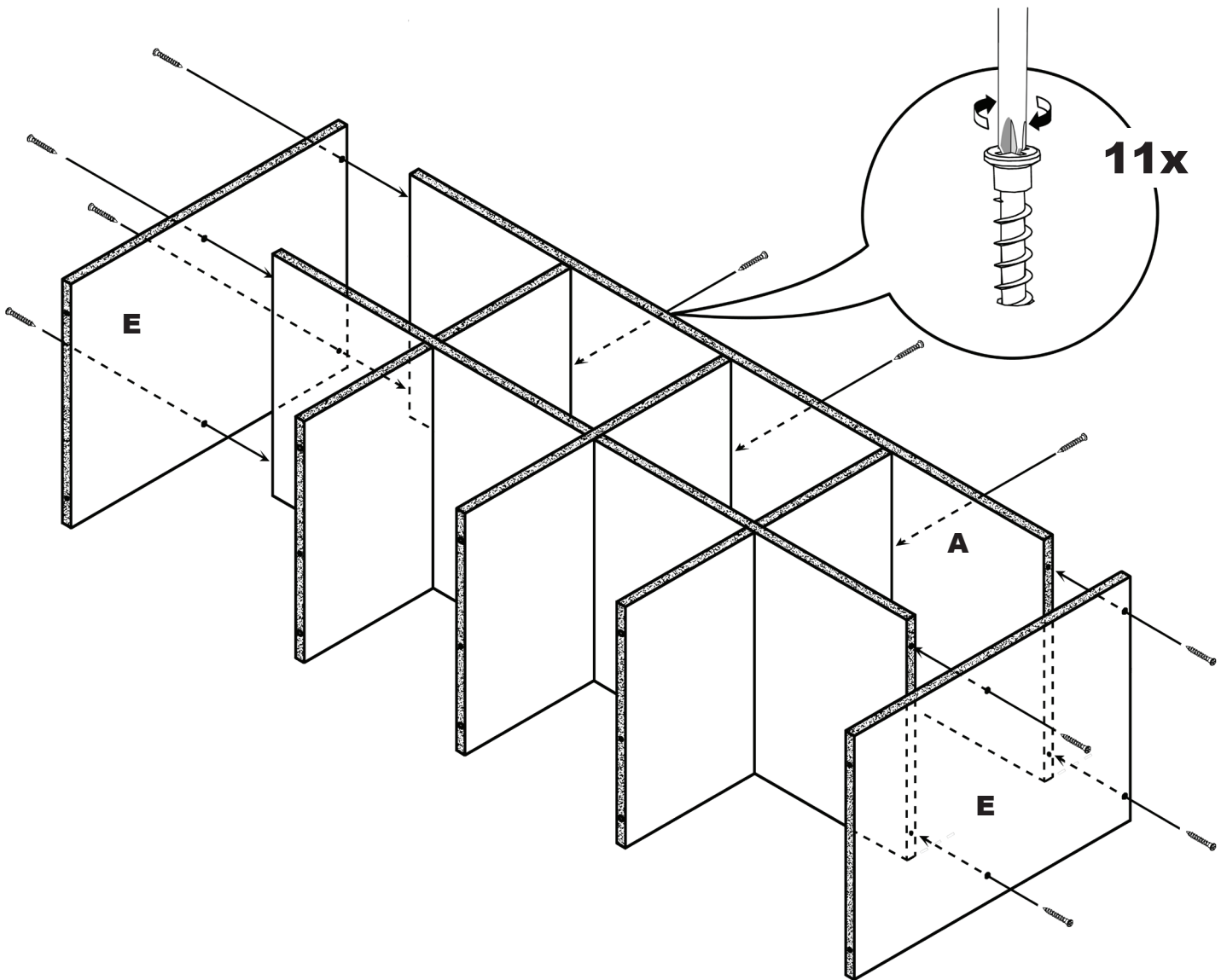
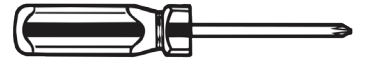

**CLOSETMAID®**

# 6



50514

x6



40942

x7



## 1)

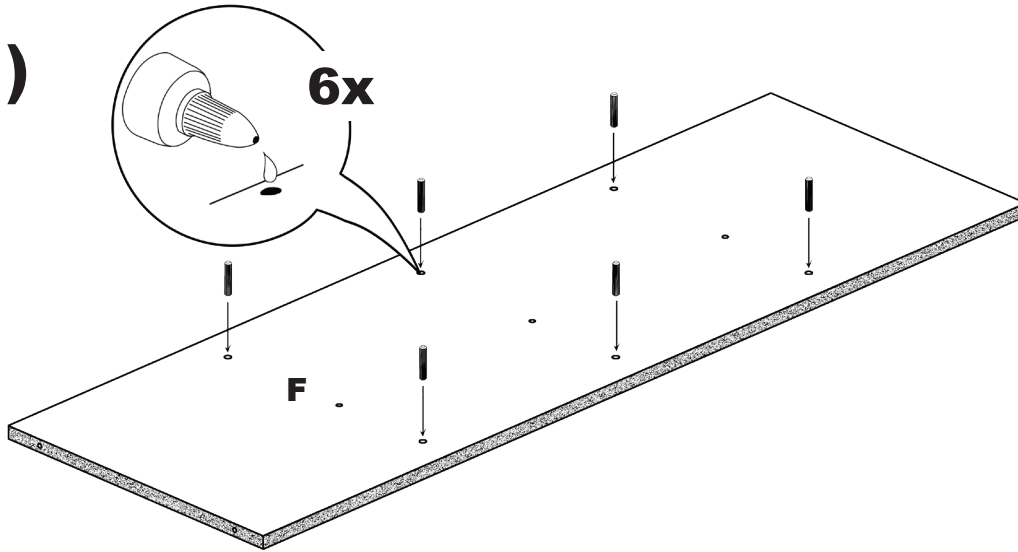

## 2)

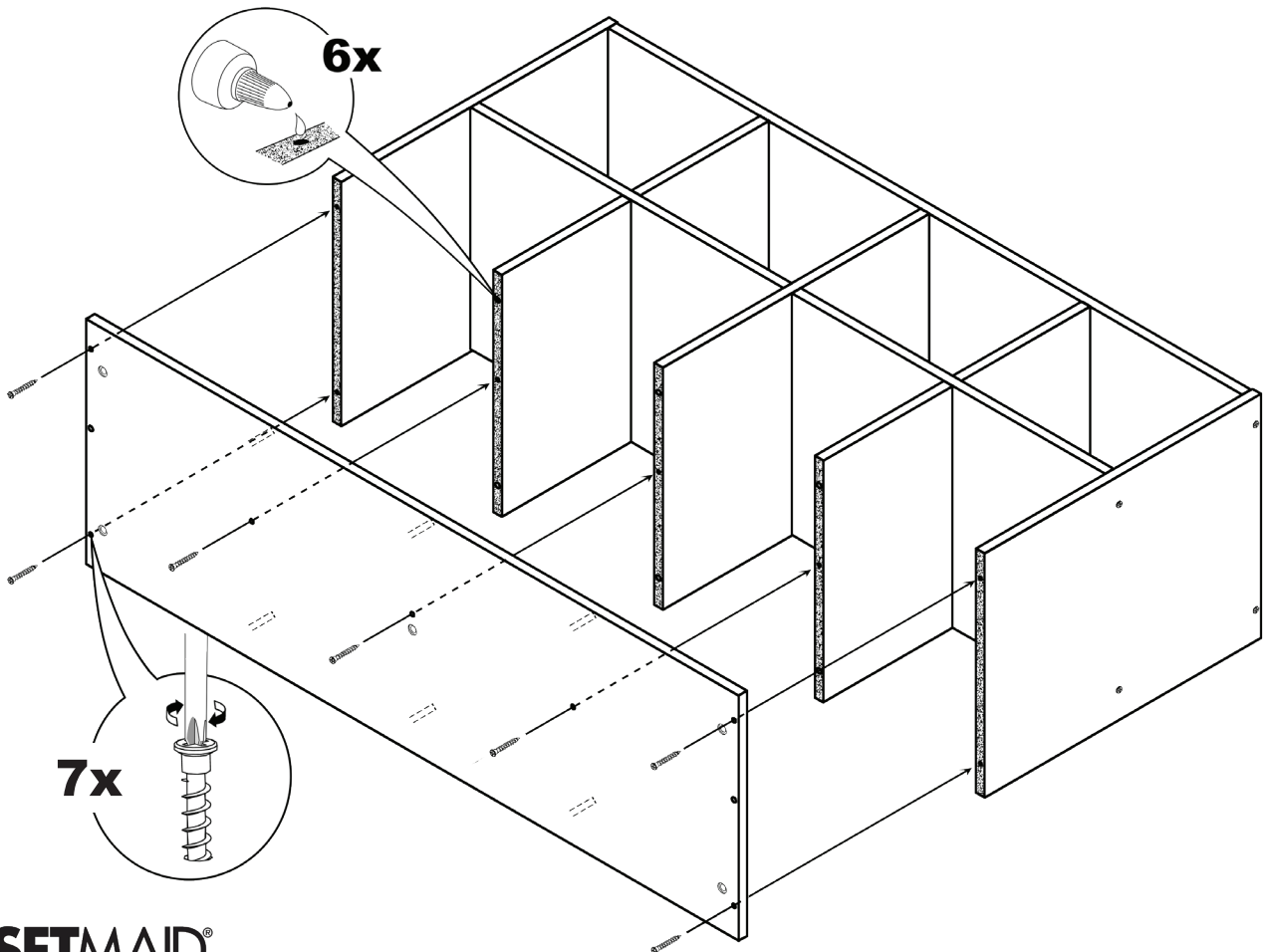

**CLOSETMAID**

# 7

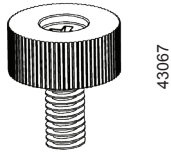

x5

 **CAUTION: DO NOT INSTALL FEET ON STACKED UNITS; ONLY ON THE FLOOR UNIT.**

**ATTENTION : N'INSTALLEZ PAS LES PIEDS SUR LES ÉLÉMENTS EMPILÉS — SEULEMENT SUR L'ÉLÉMENT AU SOL.**

**PRECAUCIÓN: NO COLOQUE EL PIE EN LAS UNIDADES APILADAS... SOLO EN LA UNIDAD DEL PISO.**

GENTLY SCREW EACH FOOT INTO THE INSERT UNTIL SLIGHT RESISTANCE IS ENCOUNTERED. DO NOT OVER-TIGHTEN.

VISSER DÉLICATEMENT CHAQUE PIED DANS L'ENCART JUSQU'À CE QU'UNE LÉGÈRE RÉSISTANCE SE FASSE SENTIR. NE PAS TROP SERRER.

ENROSQUE CADA PATA SUAVEMENTE DONDE CORRESPONDE HASTA NOTAR CIERTA RESISTENCIA. NO APRIETE DEMASIADO.

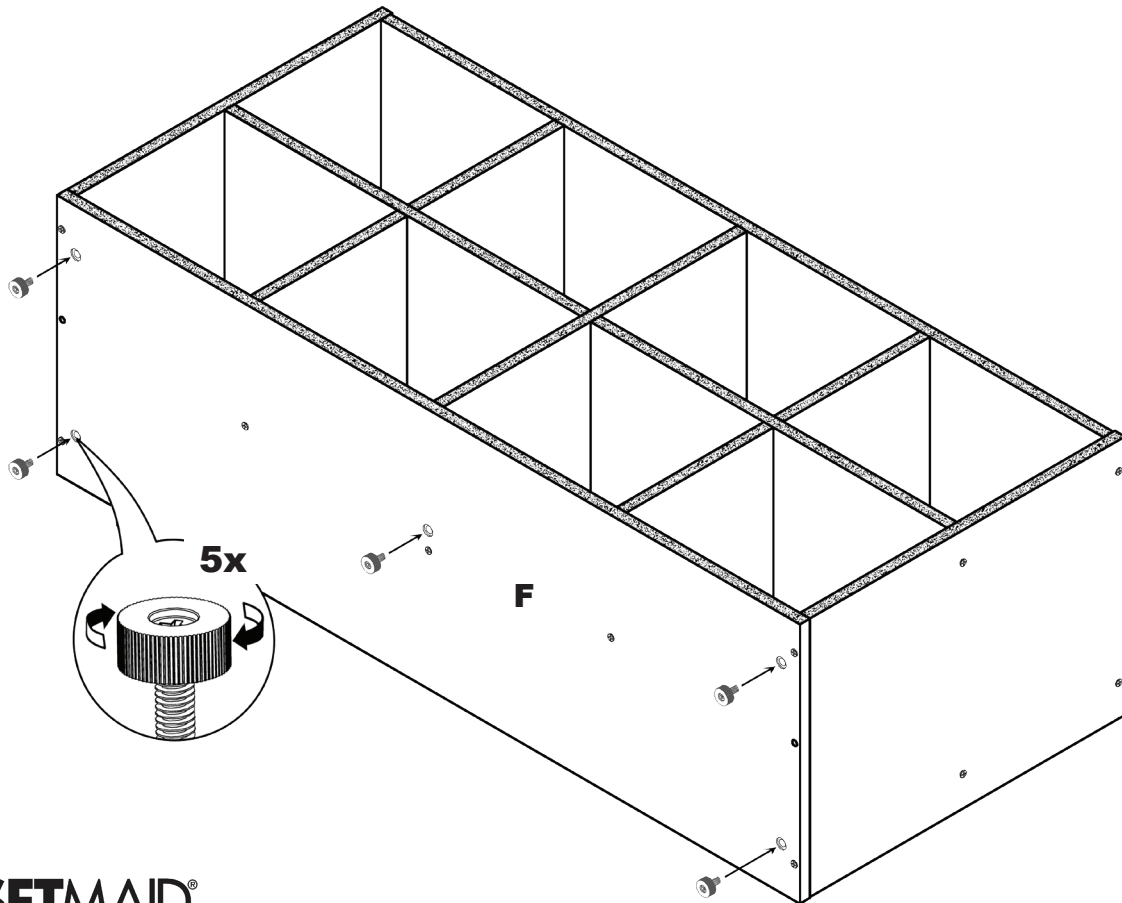

 **CLOSETMAID®**

# 8

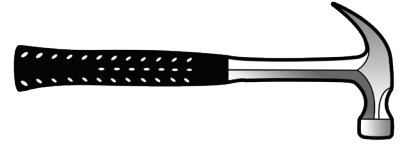
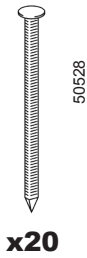

## NOTE:

- If you plan to stack units, use scissors or utility knife to cut a 3/4 in. x 1-1/4 in. hole in top center location of back panel.
- With all unfinished edges facing up, square up the unit by placing back panel onto the cabinet. Nail the back into position using nails. Avoid angling nails.

## REMARQUE:

- En prévision de la superposition, utiliser des ciseaux ou un couteau universel pour tailler un trou de 1,9 cm x 3,2 cm au centre de la partie supérieure du panneau arrière.
- Retourner l'ensemble sur le plancher, les bords non finis vers le haut. Clouez le panneau arrière avec les clous. Évitez d'enfoncer les clous de travers.

## NOTA:

- Si piensa apilar los cubos, utilice tijeras o un cuchillo para cortar un agujero de 1,9 cm x 3,2 cm en el centro superior del panel trasero.
- Coloque la unidad cara abajo en el suelo con los bordes no terminados hacia arriba. Clave el panel trasero en su lugar usando los clavos. Evite colocar los clavos en ángulo.

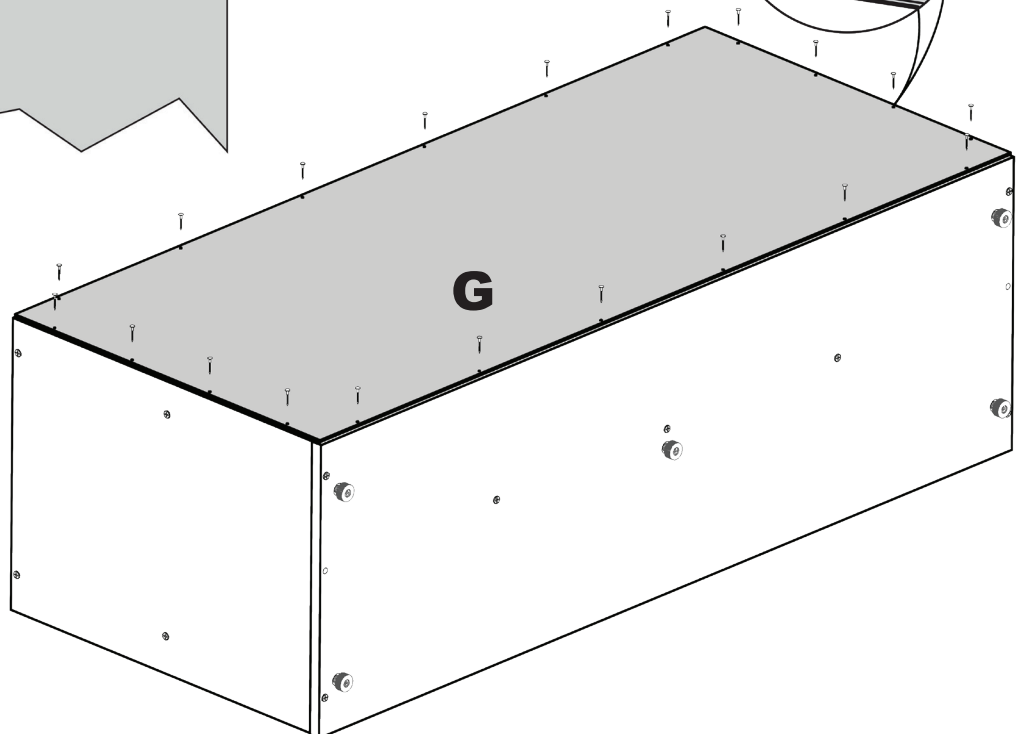
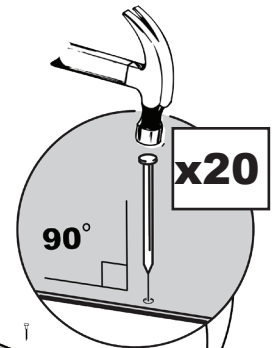
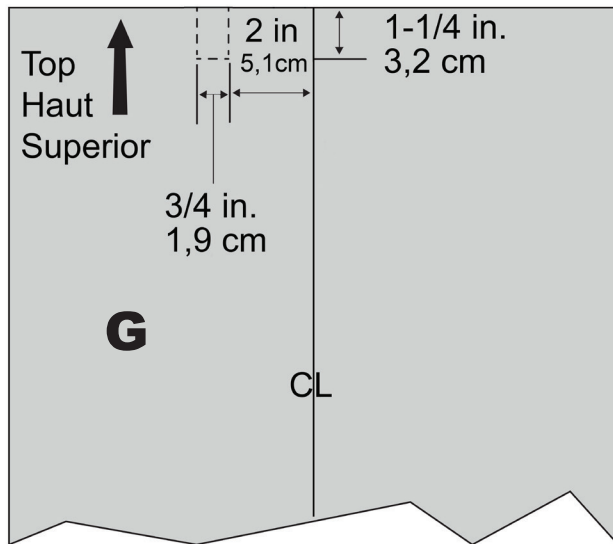

**CLOSETMAID**

# 9



x11



x2

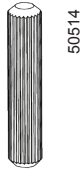

50514

x2



### NOTE:

- Locate all exposed screw heads and place cap firmly into place.
- If stacking units, place one or two drops of glue into the top holes and insert dowel.
- If single unit, place hole plugs into top holes.

### REMARQUE:

- Localisez toutes les têtes de vis exposées et mettez les capuchons en place en appuyant fermement.
- Si vous superposez les unités, déposez une ou deux gouttes de colle dans les trous du haut avant d'introduire les goujons.
- S'il y a une seule unité, placez les bouchons dans les trous supérieurs.

### NOTA:

- Localice todas las cabezas de los tornillos donde corresponden y coloque los tapones firmemente en su lugar.
- Si apila las unidades, aplique una o dos gotas de pegamento en los agujeros superiores e inserte un pasador.
- Si se trata de una sola unidad, coloque tapones en los agujeros superiores.

For single unit  
Module autonome  
Para unidades sencillas

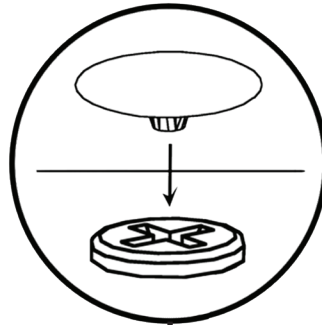

For stacking  
Modules superposés  
Para apilar

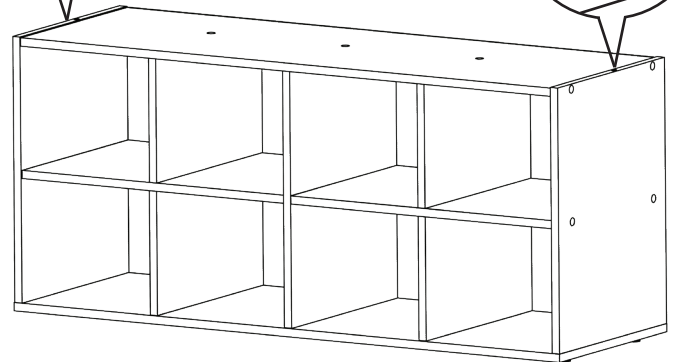
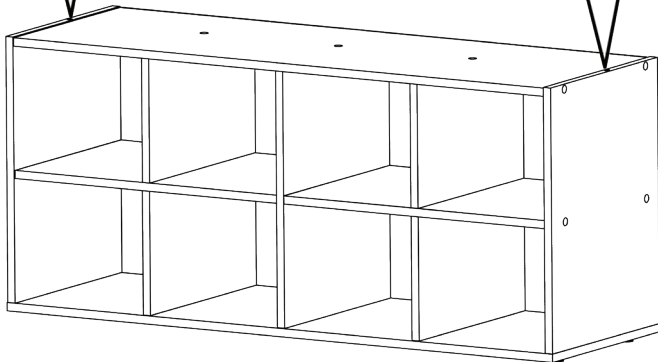
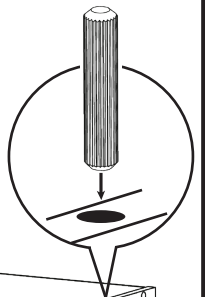
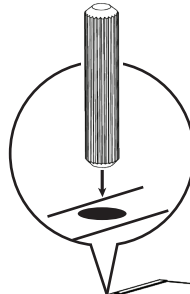
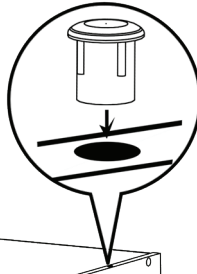
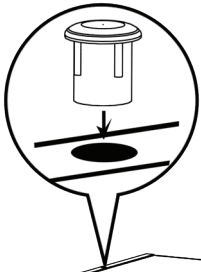

## CLOSETMAID®

# 10



x1



x1



x1



All units **MUST** be fastened to the wall. When stacking units, the unit on the bottom must be attached to the wall first before setting another unit on top. Do not stack units more than 72 in. high.

Tous les modules **DOIVENT** être attachés au mur. Pour empiler les modules, celui du bas doit d'abord être fixé au mur avant l'installation d'un autre module par dessus. Ne pas superposer les modules à plus de 183 cm.

Todas las unidades **DEBEN** sujetarse a la pared. Cuando las unidades se apilen, la unidad del fondo debe sujetarse a la pared primero antes de colocar otra unidad encima. No apile las unidades a más de 183 cm de altura.

Wall Stud  
Montante De Charpente  
Montante De Pared



For single unit  
Module autonome  
Para unidades sencillas

For stacking  
Modules superposés  
Para apilar

or  
ou  
o

