

finori GmbH
Straßäcker 2
D - 96253 Untersiemau

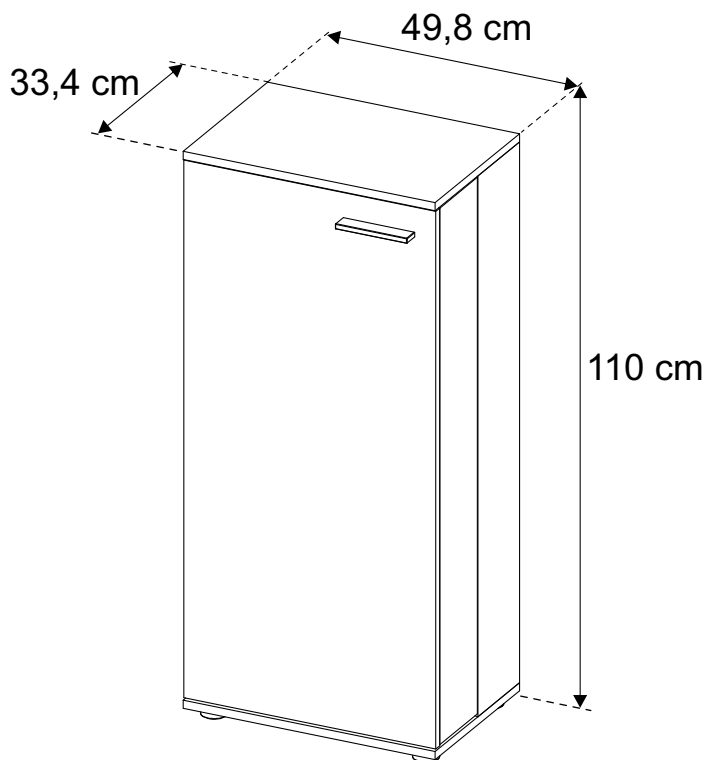

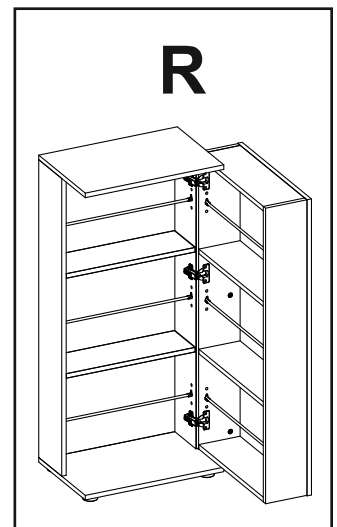
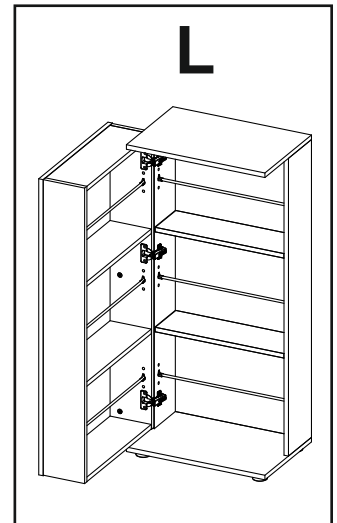
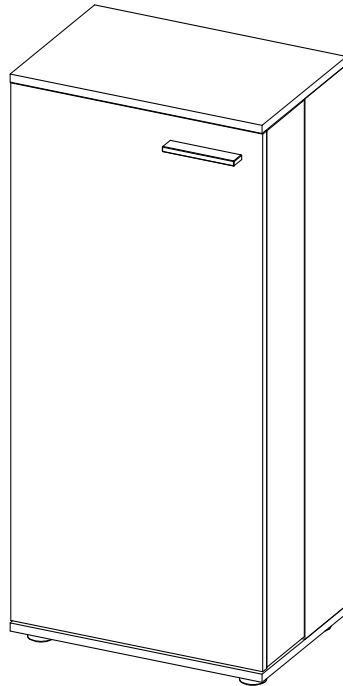
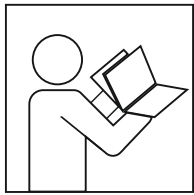

- (D) Befolgen Sie stets die Anleitung des Herstellers!
- (GB) Please generally follow the manufacturers instructions!
- (FR) Suivez toujours les instructions du fabricant!
- (NL) Volg steeds de handleiding van de producent!
- (ES) Siga siempre las instrucciones del fabricante!
- (PL) Stale przestrzegaj instrukcji producenta!

- (RU) Всегда следуйте инструкции производителя!
- (IT) Seguire sempre le istruzioni del produttore!
- (HU) Mindig tartsa be a gyártó utasításait!
- (P) Siga sempre as instruções do fabricante!
- (CZ) Vždy dodržujte pokyny výrobce!
- (SK) Vždy dodržujte pokyny výrobcu!

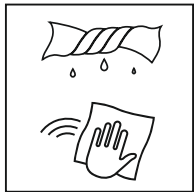

- (D) Verwenden Sie zur Reinigung nur ein feuchtes Tuch!
- (GB) Please only clean with a damp cloth!
- (FR) N'utilisez qu'un chiffon humide pour le nettoyage!
- (NL) Gebruik voor de reiniging enkel een vochtige doek!
- (ES) Para limpiar utilice sólo un paño húmedo!
- (PL) Do czyszczenia używaj wilgotnej szmatki!

- (RU) Для очистки используйте только влажную ткань!
- (IT) Per la pulizia, utilizzare solo un panno umido!
- (HU) A tisztításhoz elegendő egy nedves kendő használatát!
- (P) Para a limpeza use apenas um pano húmido!
- (CZ) Pro čištění používejte pouze vlhký hadřík!
- (SK) Na čistenie používajte iba vlhkú handričku!

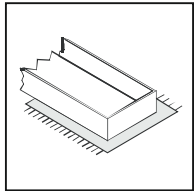

- (D) Bauen Sie das Produkt auf einer Unterlage auf!
- (GB) Please mount the product on a bottom support!
- (FR) Montez le produit sur une base!
- (NL) Monteer het product op een basis!
- (ES) Monte el producto sobre una base!
- (PL) Rozkładaj produkt na podkładce!

- (RU) Собирайте изделие на подстилке!
- (IT) Montare il prodotto su un supporto!
- (HU) Az összeszereléskor helyezzen a termék alá megfelelő alátétet!
- (P) Monte o produto numa superfície plana!
- (CZ) Výrobek smontujte na pevném podkladu!
- (SK) Výrobok zmontujte na pevnom podklade!

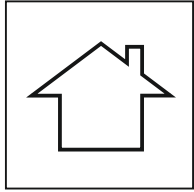

- (D) Verwenden Sie das Produkt nur in Innenräumen!
- (GB) Please exclusively use the product indoors!
- (FR) N'utilisez le produit qu'à l'intérieur!
- (NL) Gebruik het product enkel binnenshuis!
- (ES) Utilice el producto sólo en interiores!
- (PL) Używaj produkt tylko w pomieszczeniach wewnętrznych!

- (RU) Используйте изделие только во внутренних помещениях!
- (IT) Utilizzare il prodotto solo in ambienti interni!
- (HU) A termék csak bel terekben használható!
- (P) Use o produto apenas no interior!
- (CZ) Používejte výrobek pouze uvnitř!
- (SK) Výrobok používajte len vo vnútri!

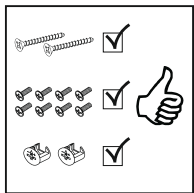

- (D) Legen Sie die Beschläge zusammen und prüfen Sie die Vollständigkeit!
- (GB) Please join the fittings and verify their completeness!
- (FR) Pliez les raccords ensemble et vérifiez qu'ils sont complets!
- (NL) Leg de onderdelen samen en controleer de volledigheid!
- (ES) Junte los accesorios y compruebe que están todos!
- (PL) Rozłóż poszczególne części i sprawdź kompletność!

- (RU) Положите фурнитуру в одно место и проверьте комплектности!
- (IT) Mettere insieme le guarnizioni e verificarne la completezza!
- (HU) Állítsa össze a sarokvasakat, és ellenőrizze, hogy épek-e!
- (P) Coloque os encaixes juntos e verifique se estão completos!
- (CZ) Složte armatury a zkontrolujte úplnost!
- (SK) Zložte armatúry a skontrolujte úplnosť!



- (D) Bei fehlenden Teilen kontaktieren Sie den Hersteller!
- (GB) If parts are missing, please turn to the manufacturer!
- (FR) En cas de pièces manquantes, veuillez contacter le fabricant!
- (NL) Contacteer de fabrikant als er onderdelen ontbreken!
- (ES) En el caso de que falten piezas, póngase en contacto con el fabricante!
- (PL) W razie braku części skontaktuj się z producentem!

- (RU) При отсутствии каких-либо частей обратитесь к производителю!
- (IT) In caso di pezzi mancanti, contattare il produttore!
- (HU) Ha hiányozna valamelyik elem, lépjen kapcsolatba a gyártóval!
- (P) Em caso de peças em falta, entre em contato com o fabricante!
- (CZ) Pro chybějící díly kontaktujte výrobce!
- (SK) Ak vám chýbajú diely kontaktujte výrobcu!

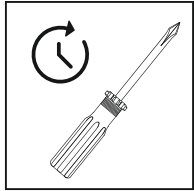

- (D) Ziehen Sie die Schrauben nach einiger Zeit des Gebrauchs erneut fest!
- (GB) Please re-tighten the screws after having used the product for a while!
- (FR) Resserrer les vis après un certain temps d'utilisation!
- (NL) Draai de schroeven na een zekere gebruikstijd opnieuw vast!
- (ES) Asegure de nuevo los tornillos tras usarlo durante un tiempo!
- (PL) Po pewnym czasie użytkowania ponownie dokręć śruby!

- (RU) Спустя некоторое время использования подкрутите гайки!
- (IT) Stringere nuovamente le viti dopo un certo periodo di utilizzo!
- (HU) A használat során némi idő elteltével húzza meg újra a csavarokat!
- (P) Reaperte os parafusos após algum tempo de uso!
- (CZ) Po určité době používání rouby znovu utáhněte!
- (SK) Po určitej dobe používania skrutky znovu utiahnite!

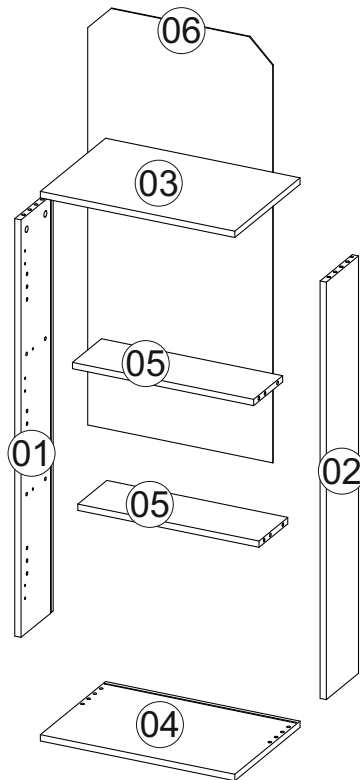
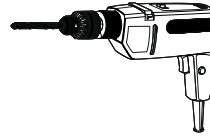
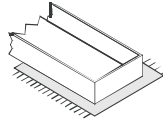
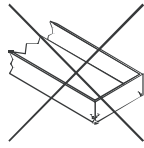
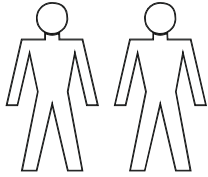
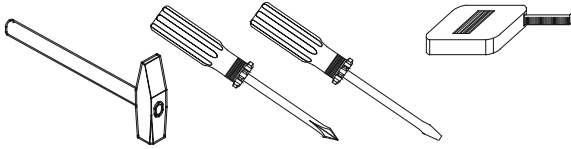

Dimensions / Abmessung in mm/		
①	1 x	1048x165x16
②	1 x	1048x165x16
③	1 x	498x334x16
④	1 x	498x334x16
⑤	6 x	464x148x16
⑥	1 x	1058x474x3
⑦	1 x	1040x149x16
⑧	1 x	1040x149x16
⑨	1 x	1042x498x16

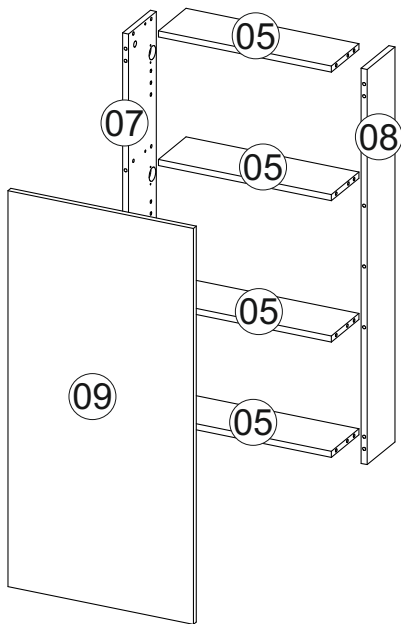

BOX 1

1x01; 1x02; 1x03; 1x04; 6x05; 1x06; 1x07; 1x08; 1x09;

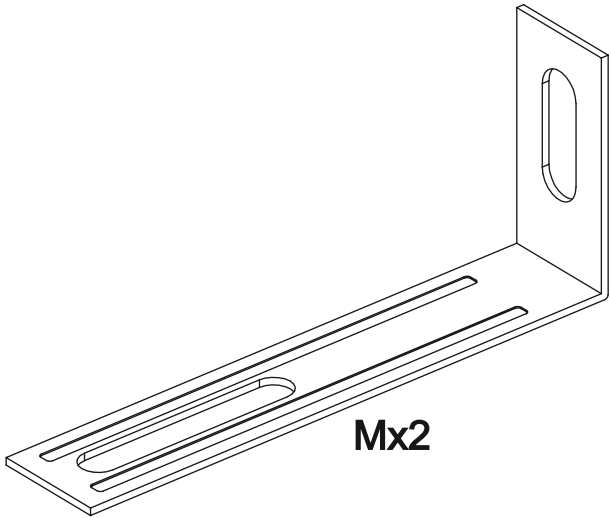
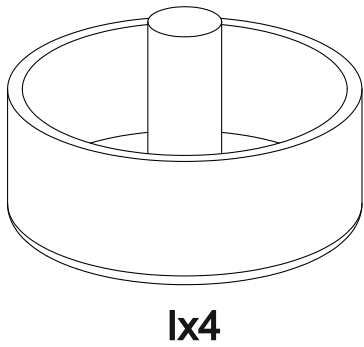
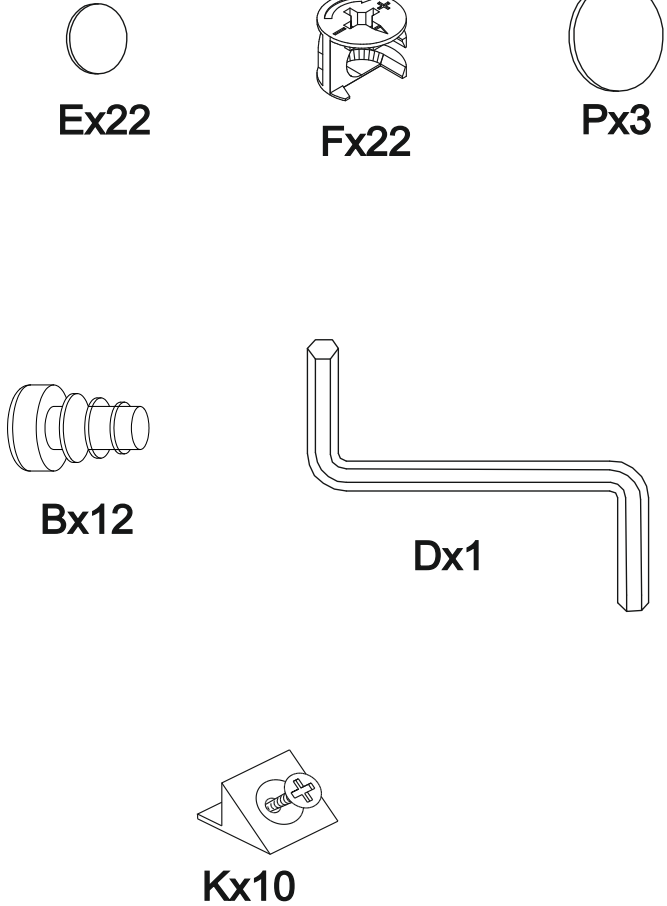
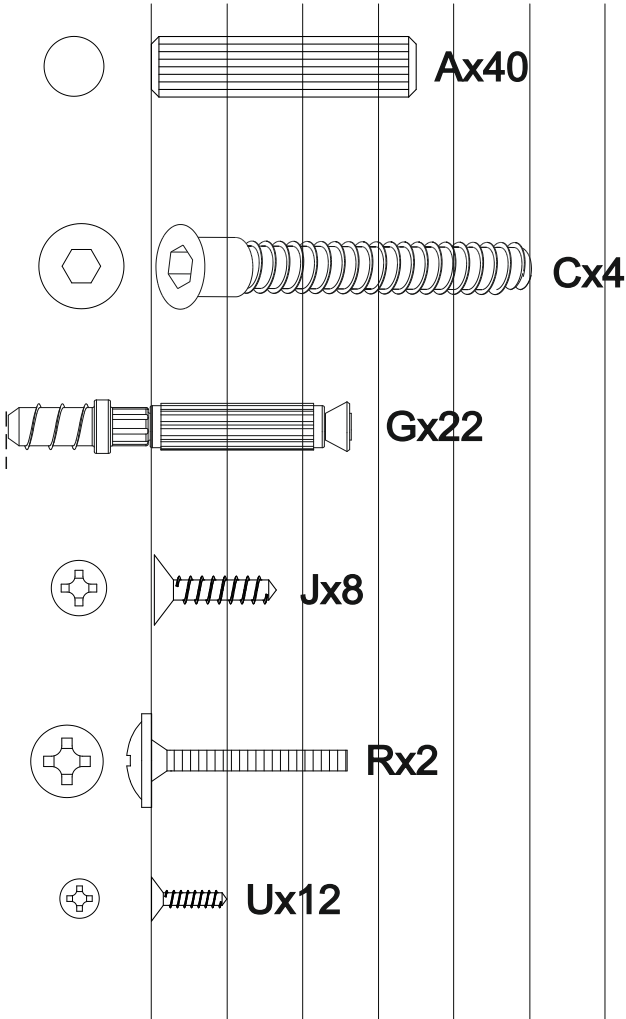
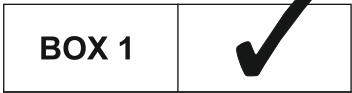
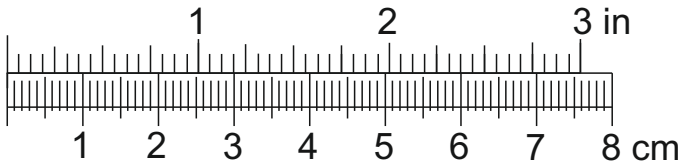

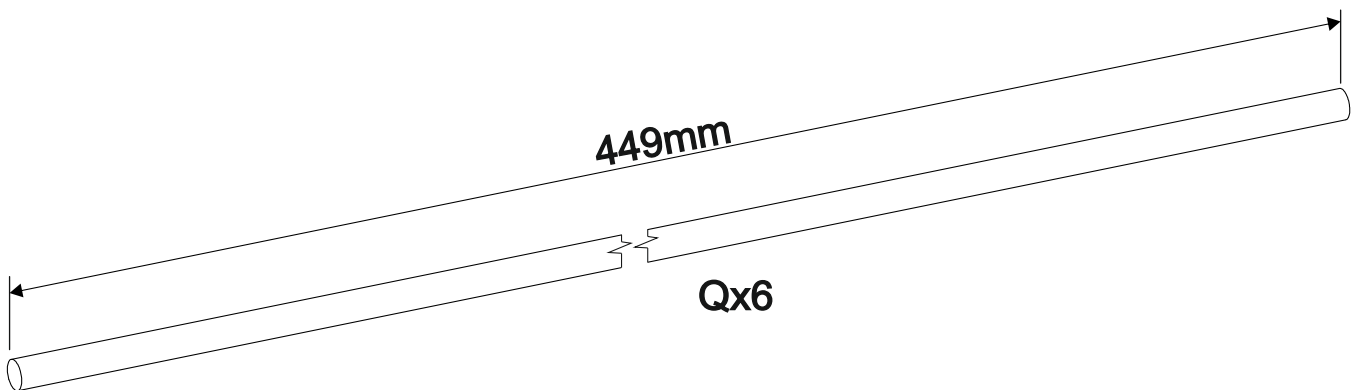
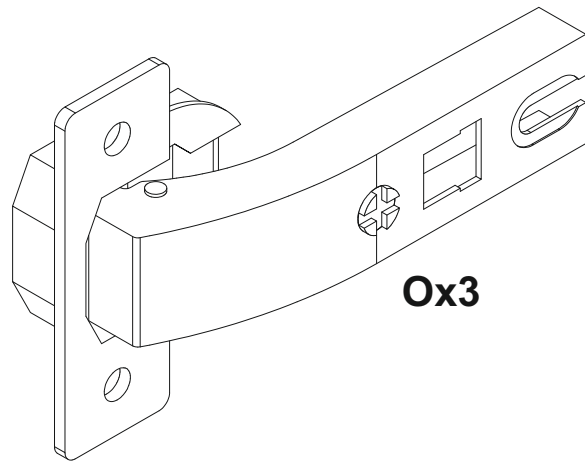
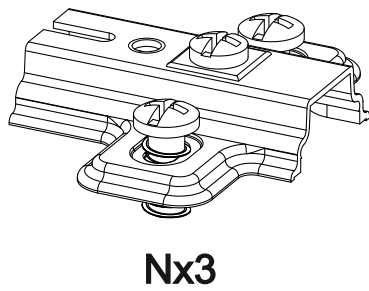
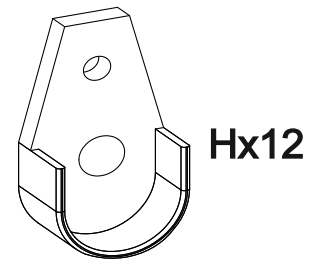
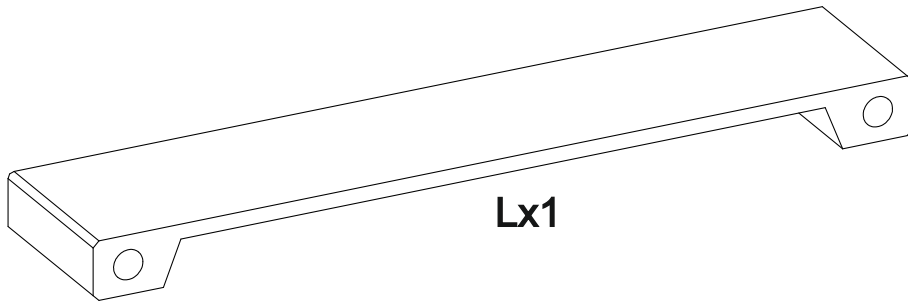
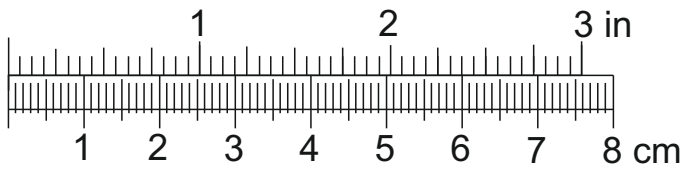

A

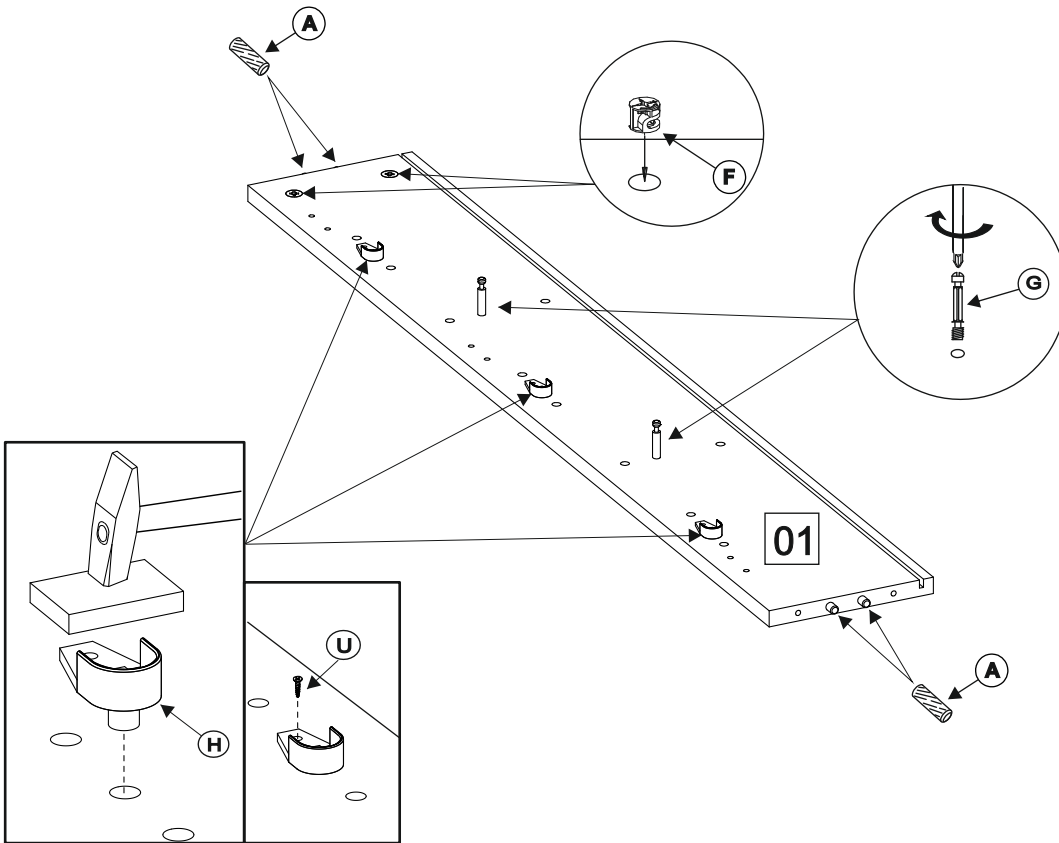

Ø8 x 35
4 x (A)

2 x (F)

2 x (G)

3 x (H)

2,5 x 10
3x (U)

B

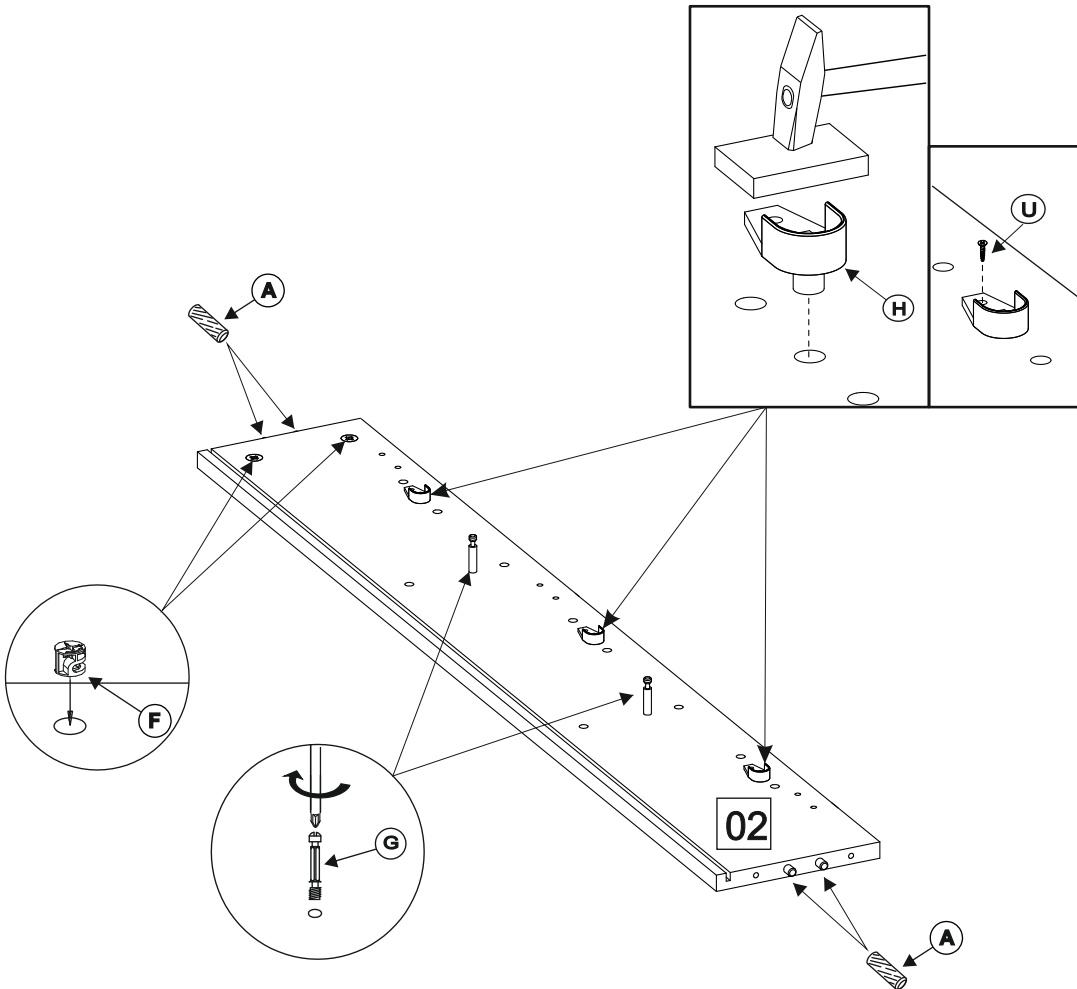

Ø8 x 35
4 x (A)

2 x (F)

2 x (G)

3 x (H)

2,5 x 10
3x (U)

C

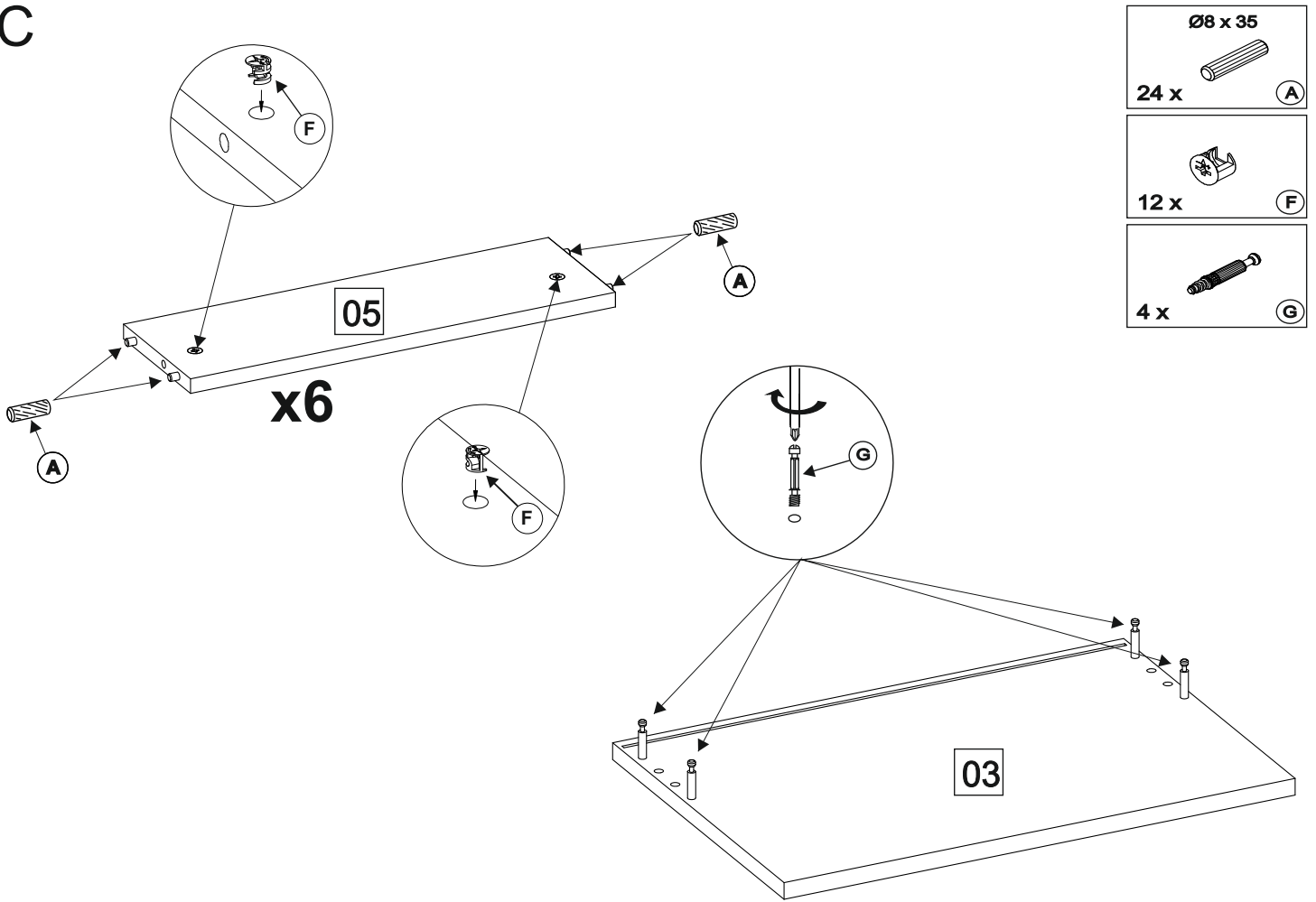

D

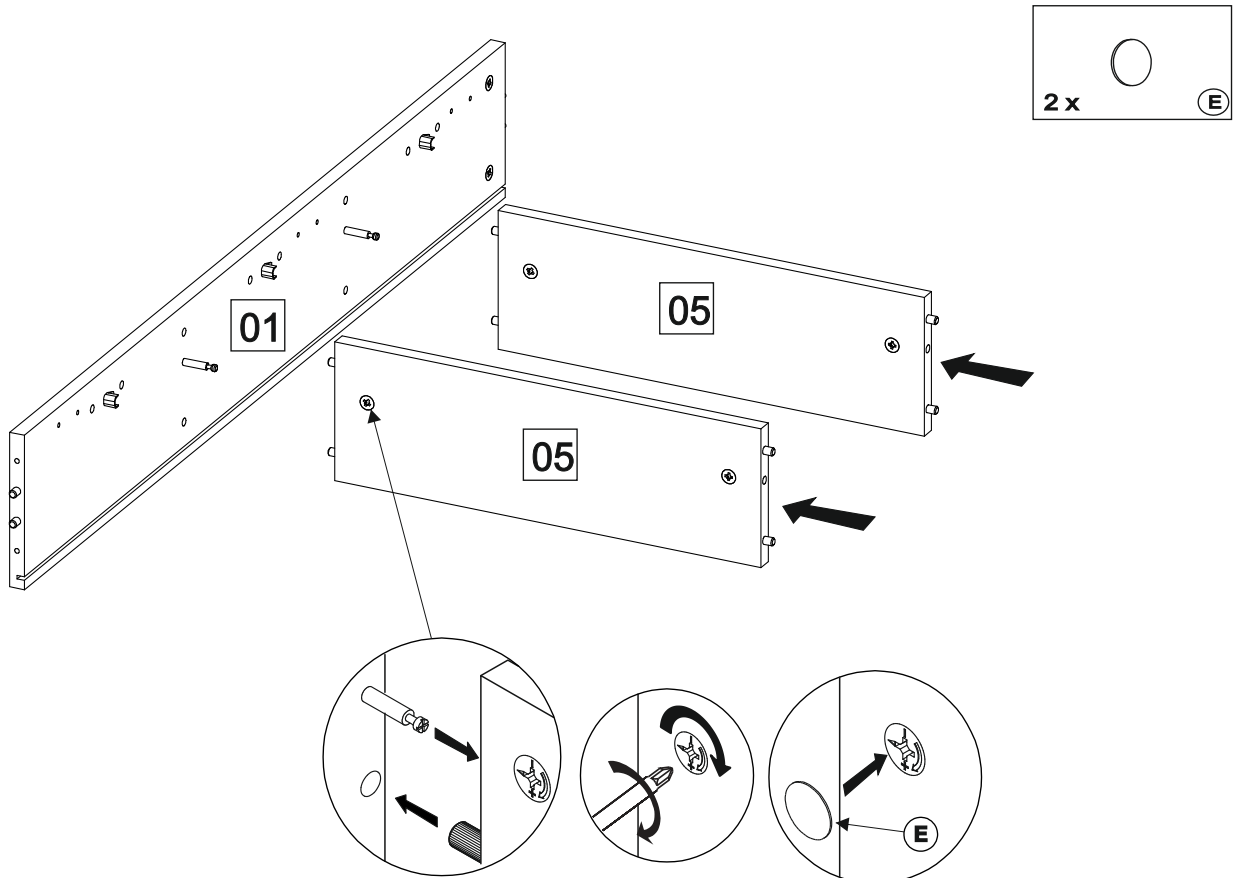

E

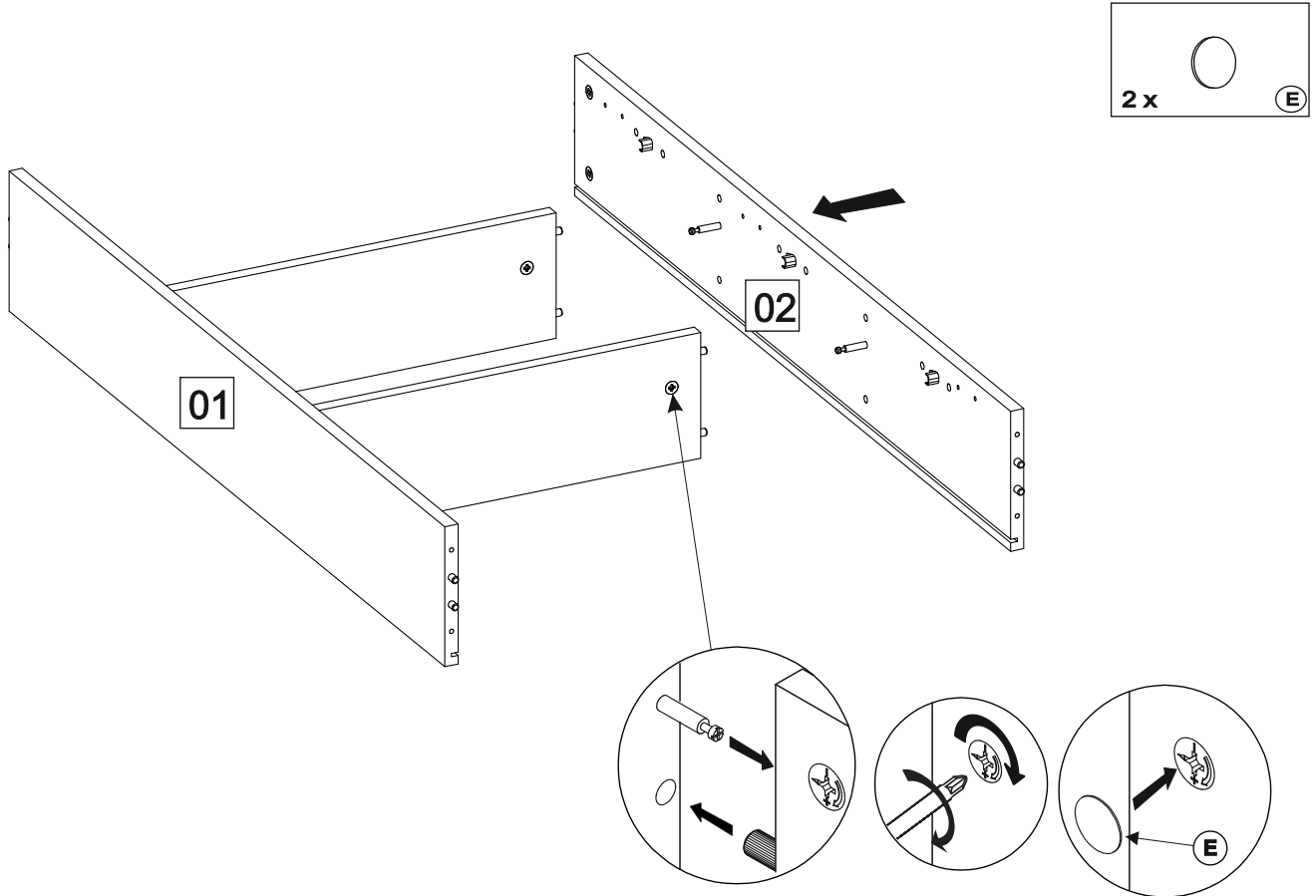

F

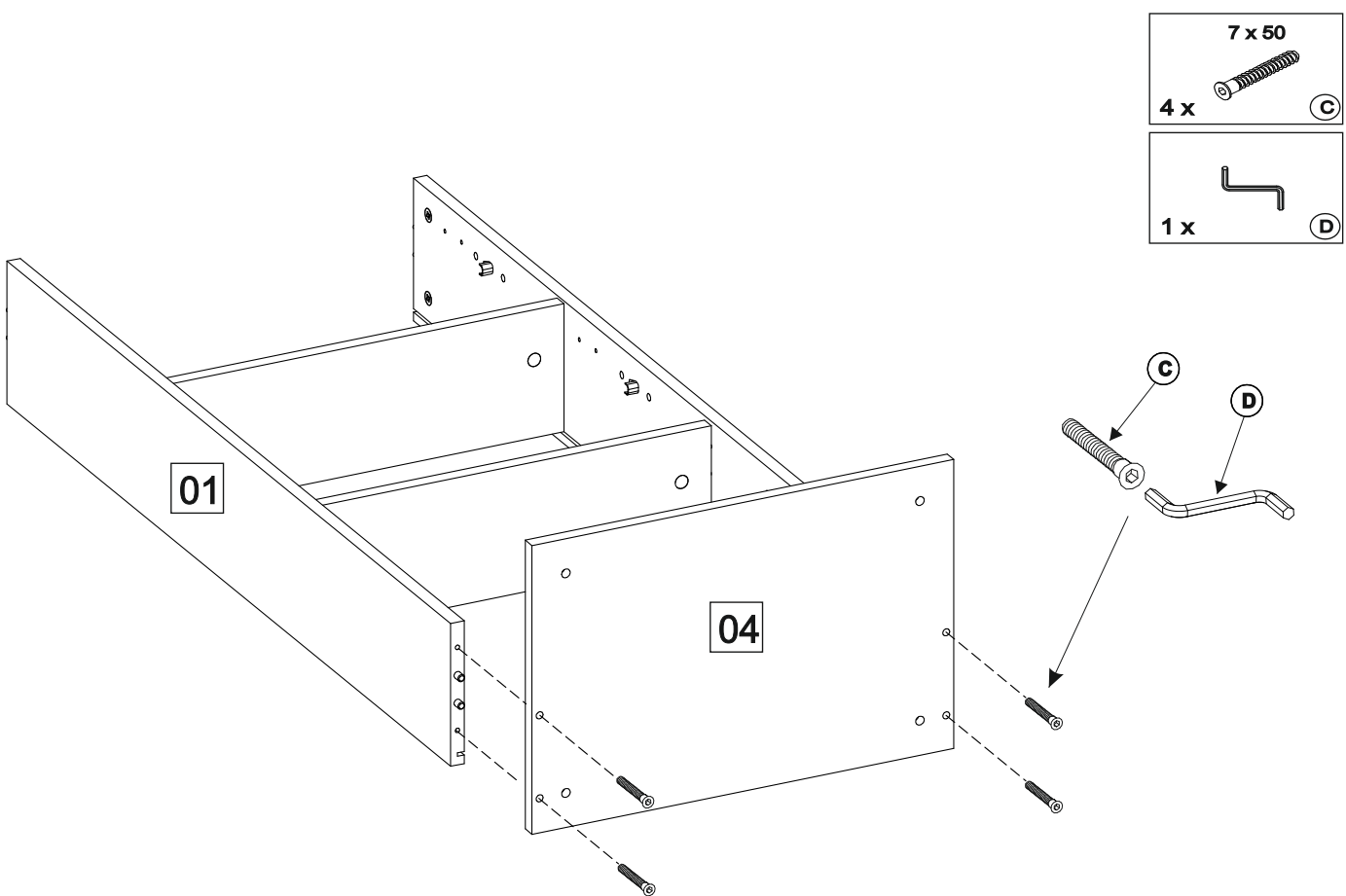

G

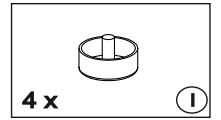
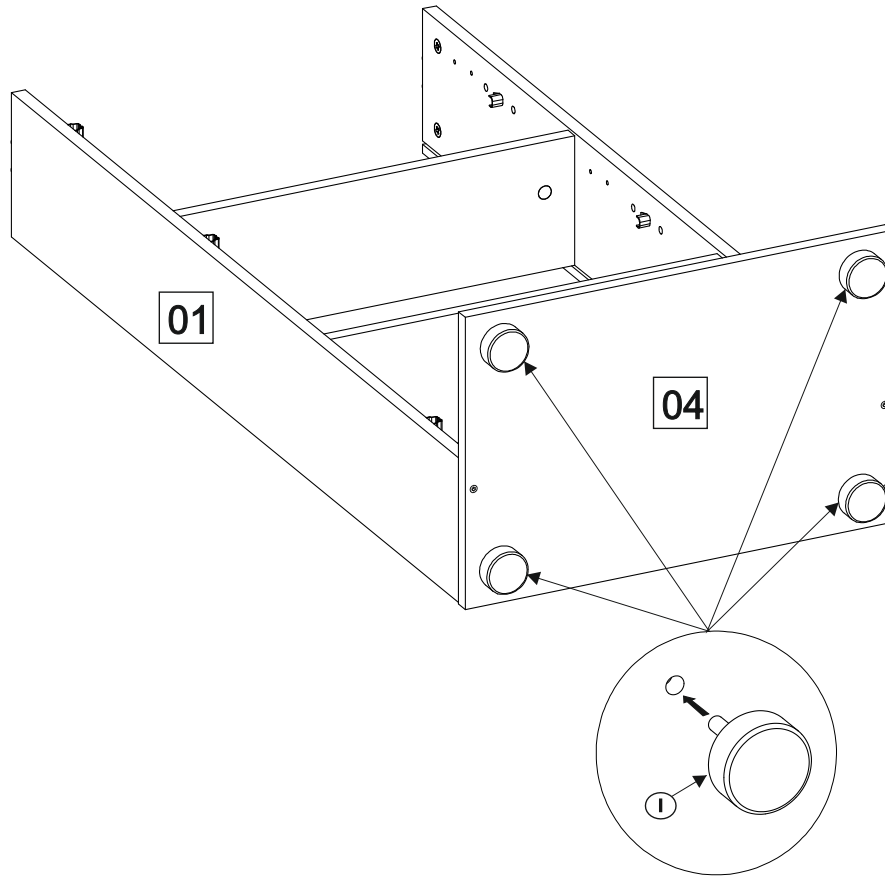

H

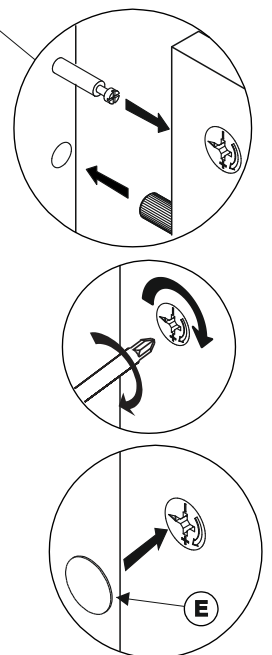
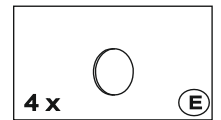
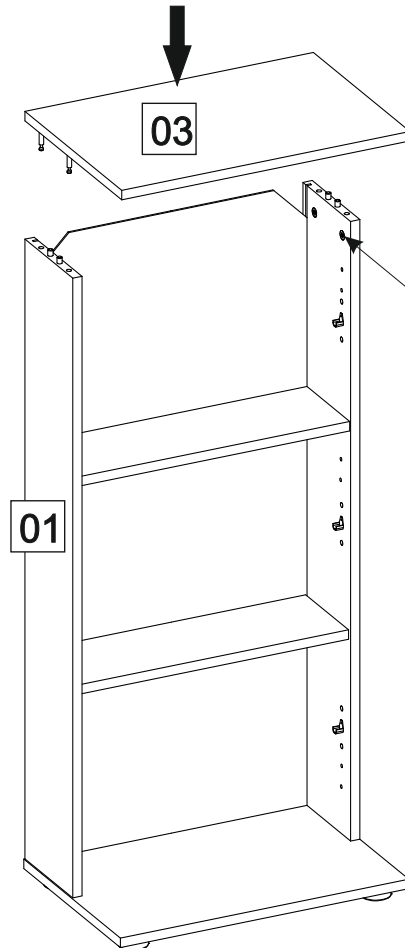
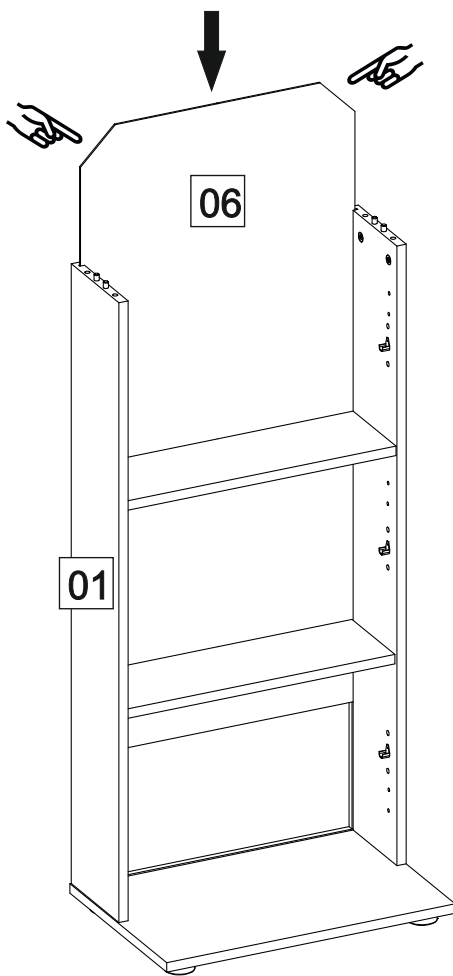

I

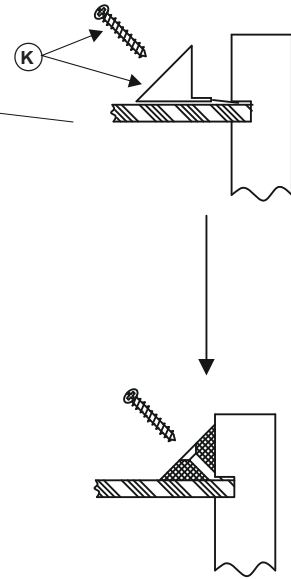
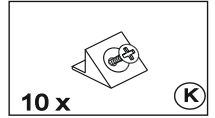
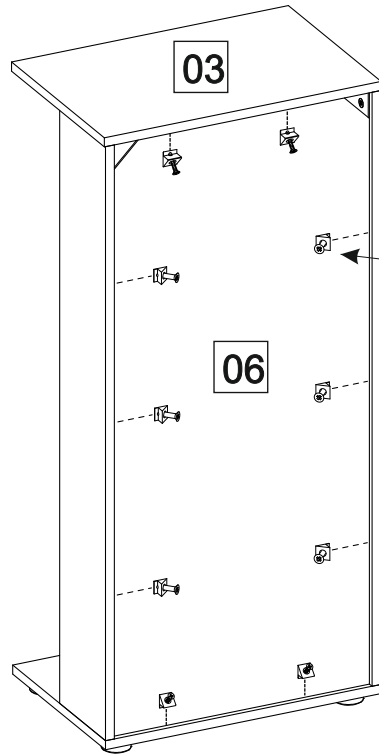

J

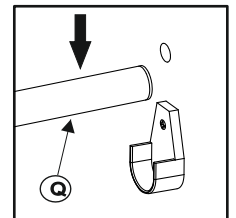
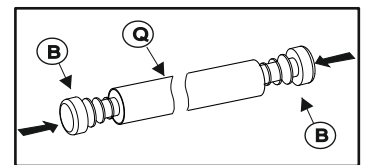
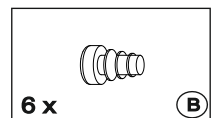
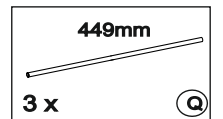
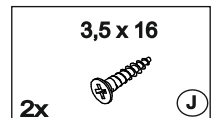
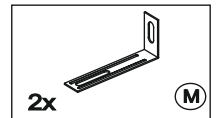
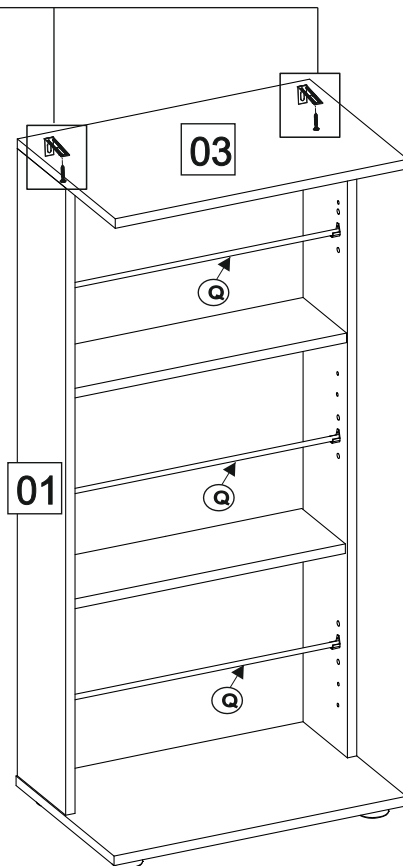
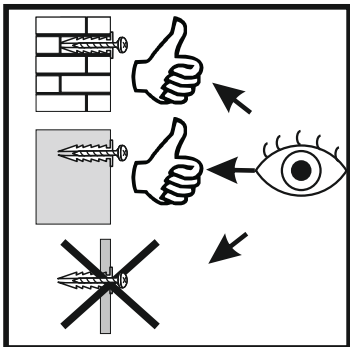
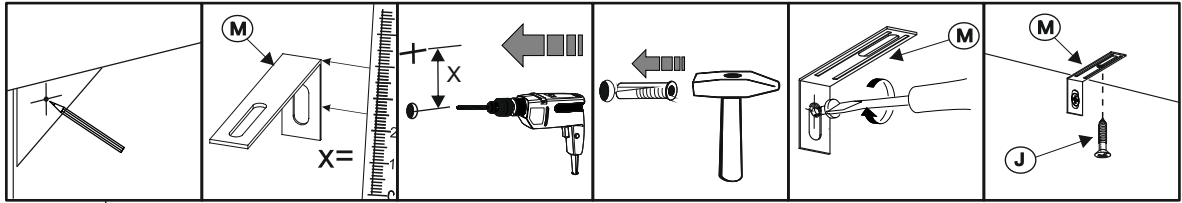

K

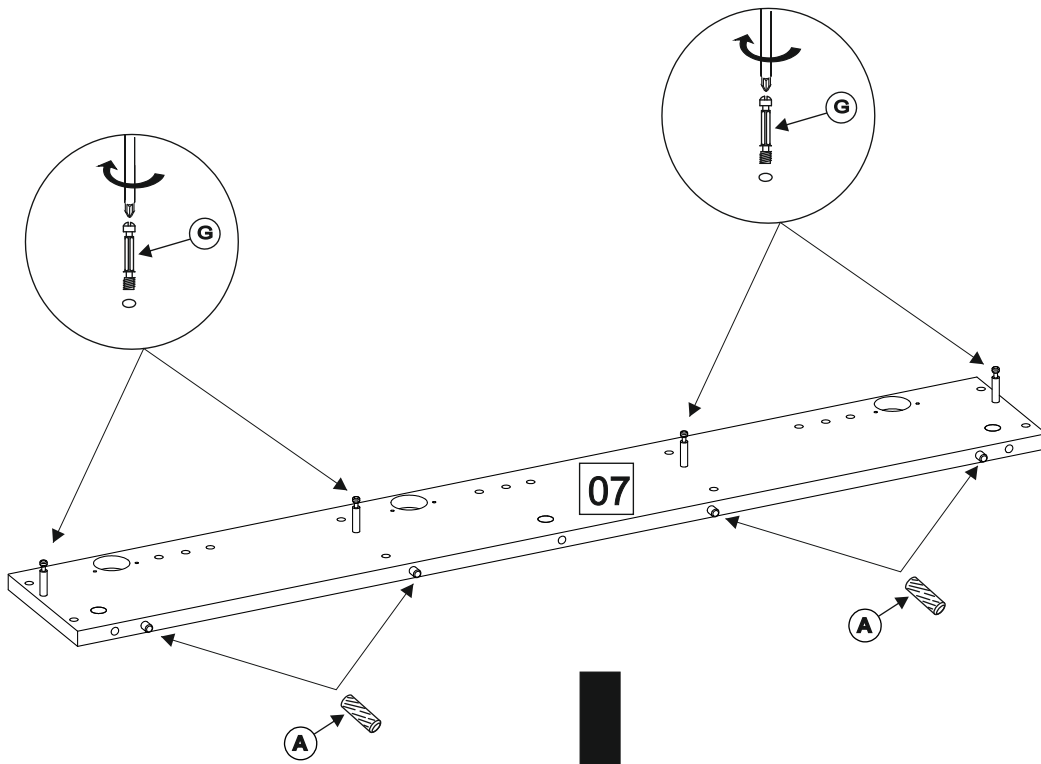

- Ø8 x 35**

4 x (A)
- 3 x** (F)
- 4 x** (G)
- 3 x** (H)
- 2,5 x 10**



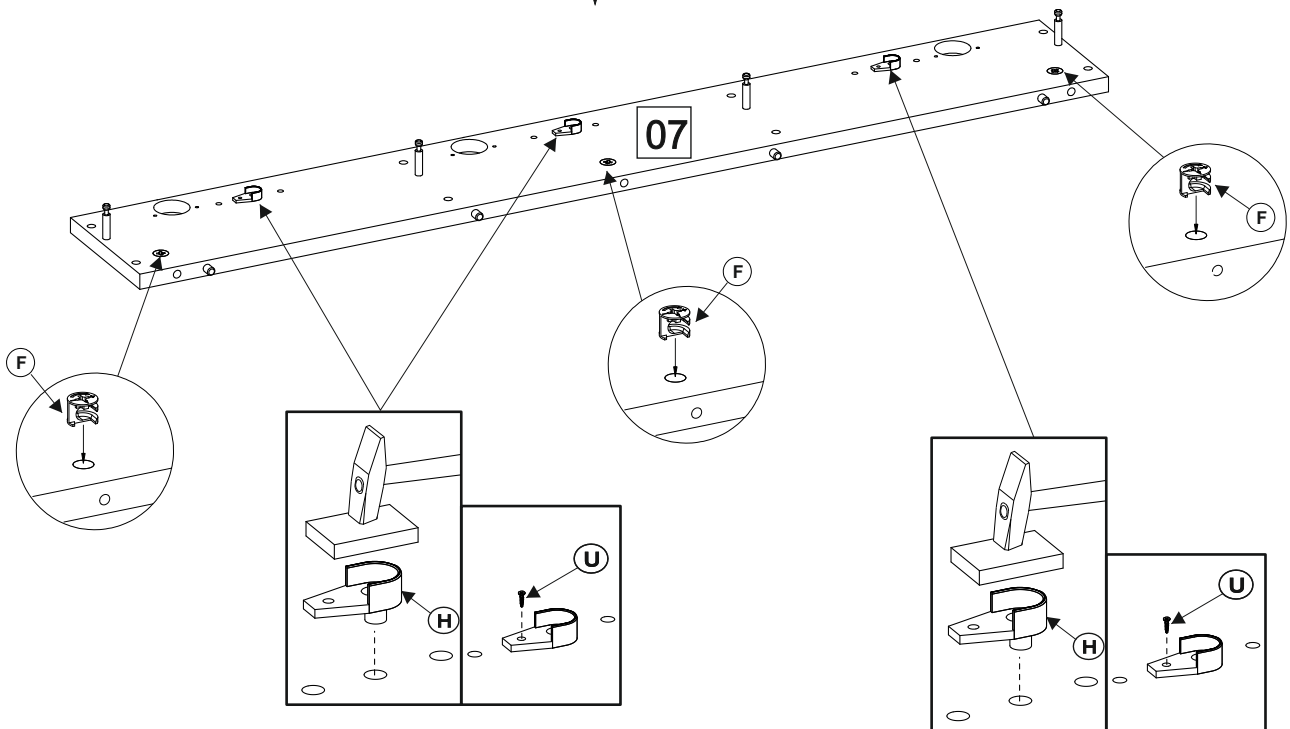

3 x (U)

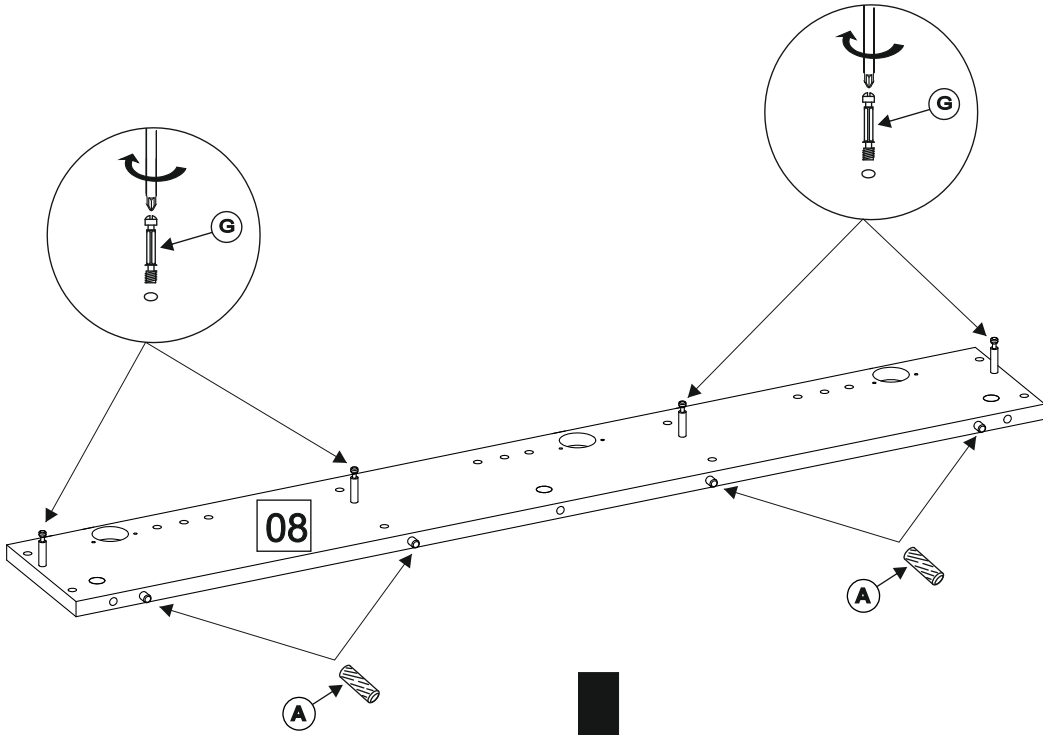

L



- Ø8 x 35**

4 x  (A)
- 3 x  (F)
- 4 x  (G)
- 3 x  (H)
- 2,5 x 10**

3 x  (U)

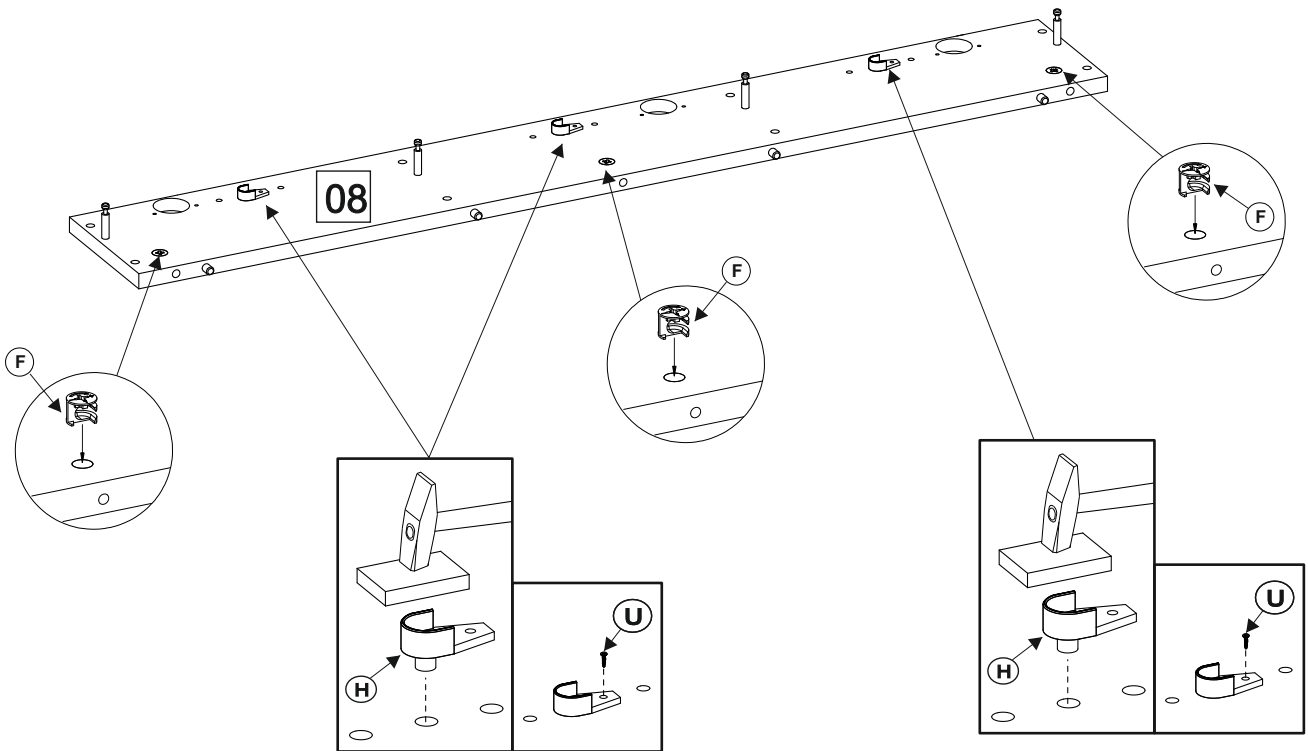

MI

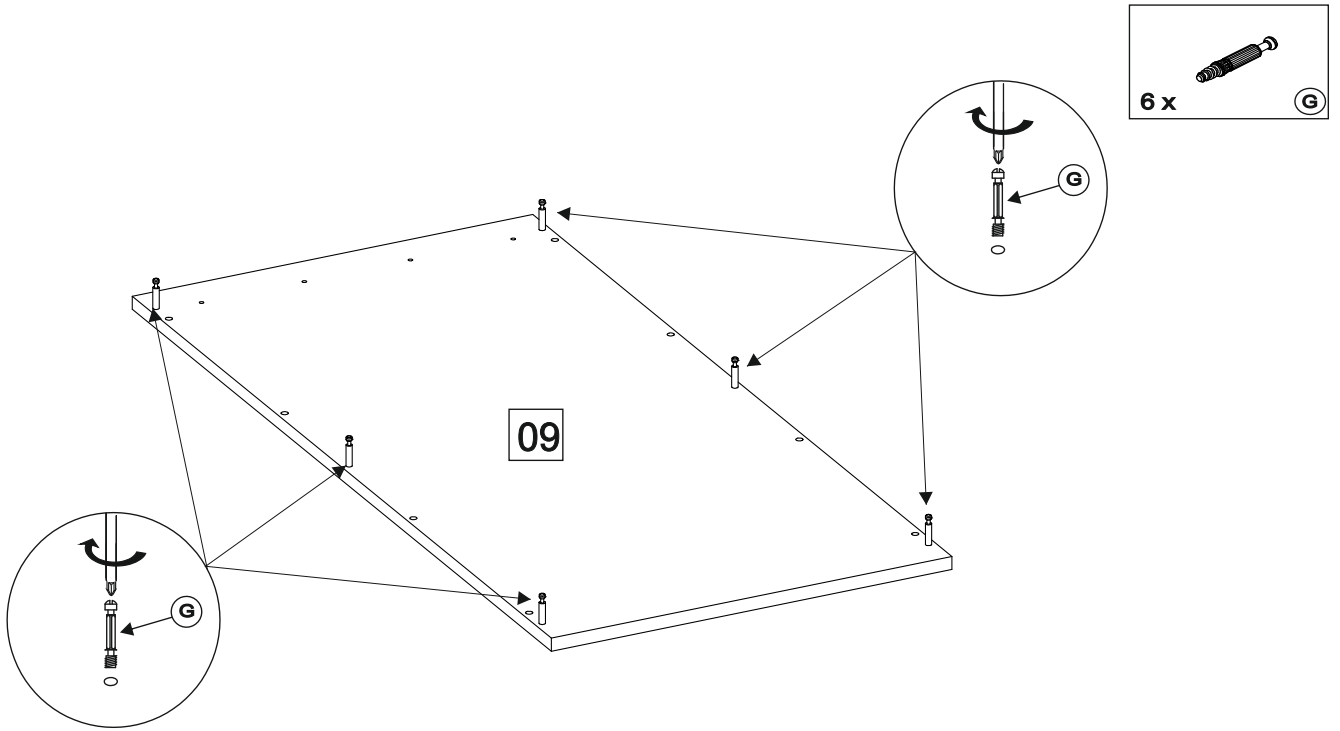

N

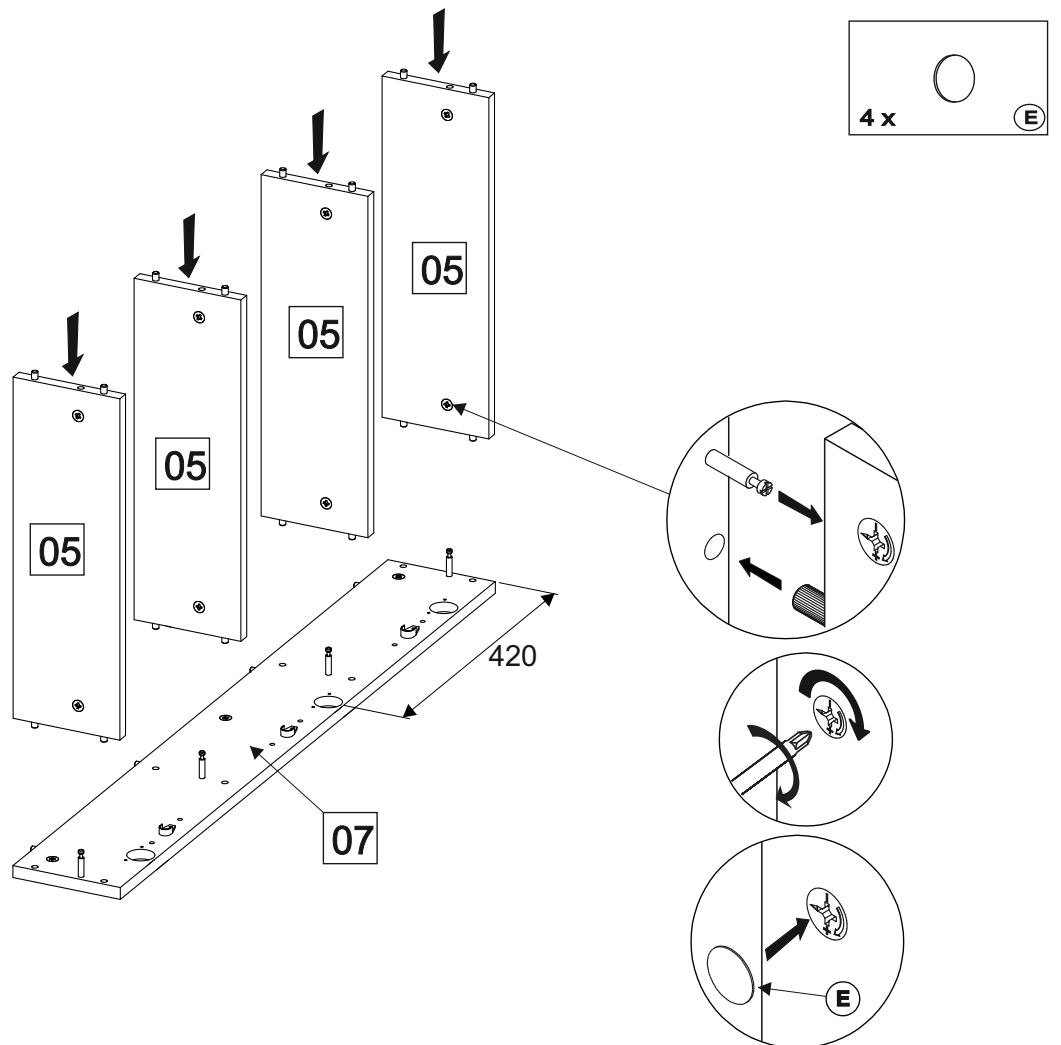

O

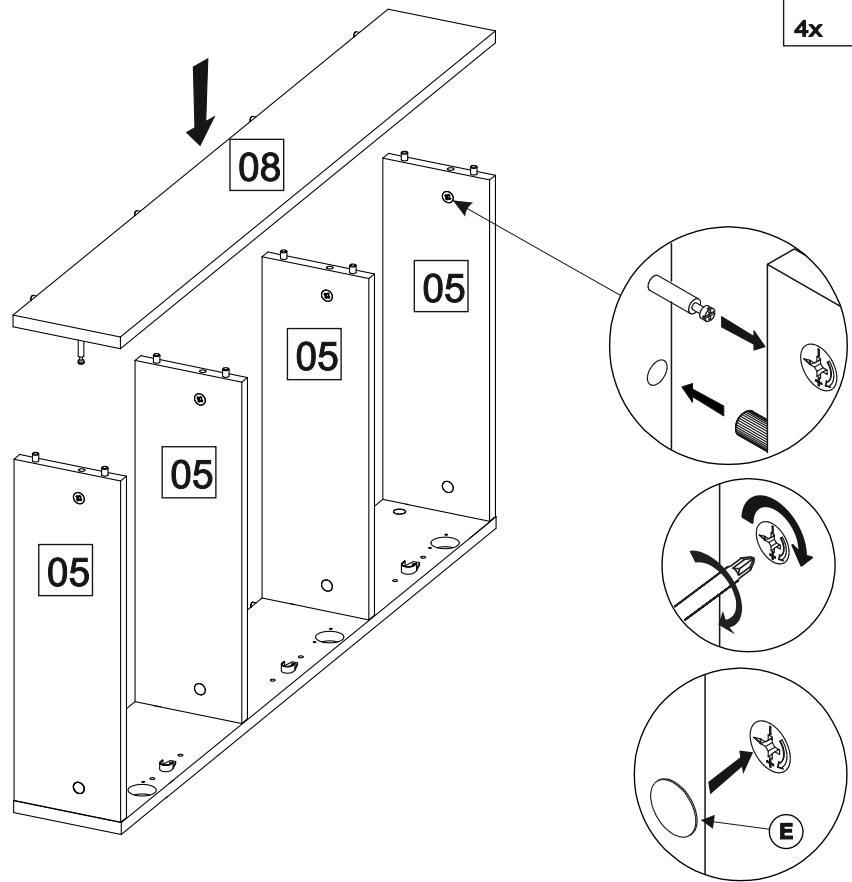

P

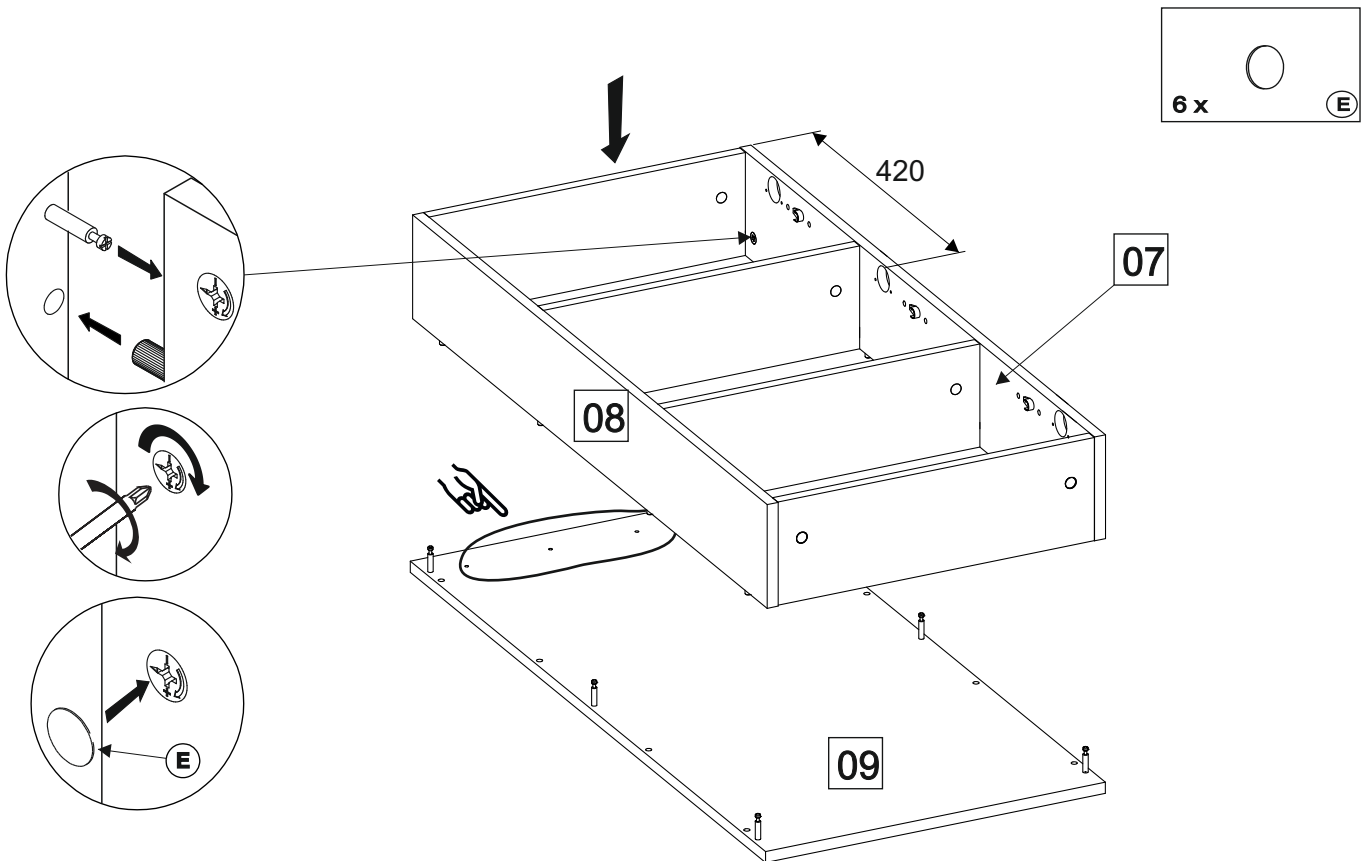

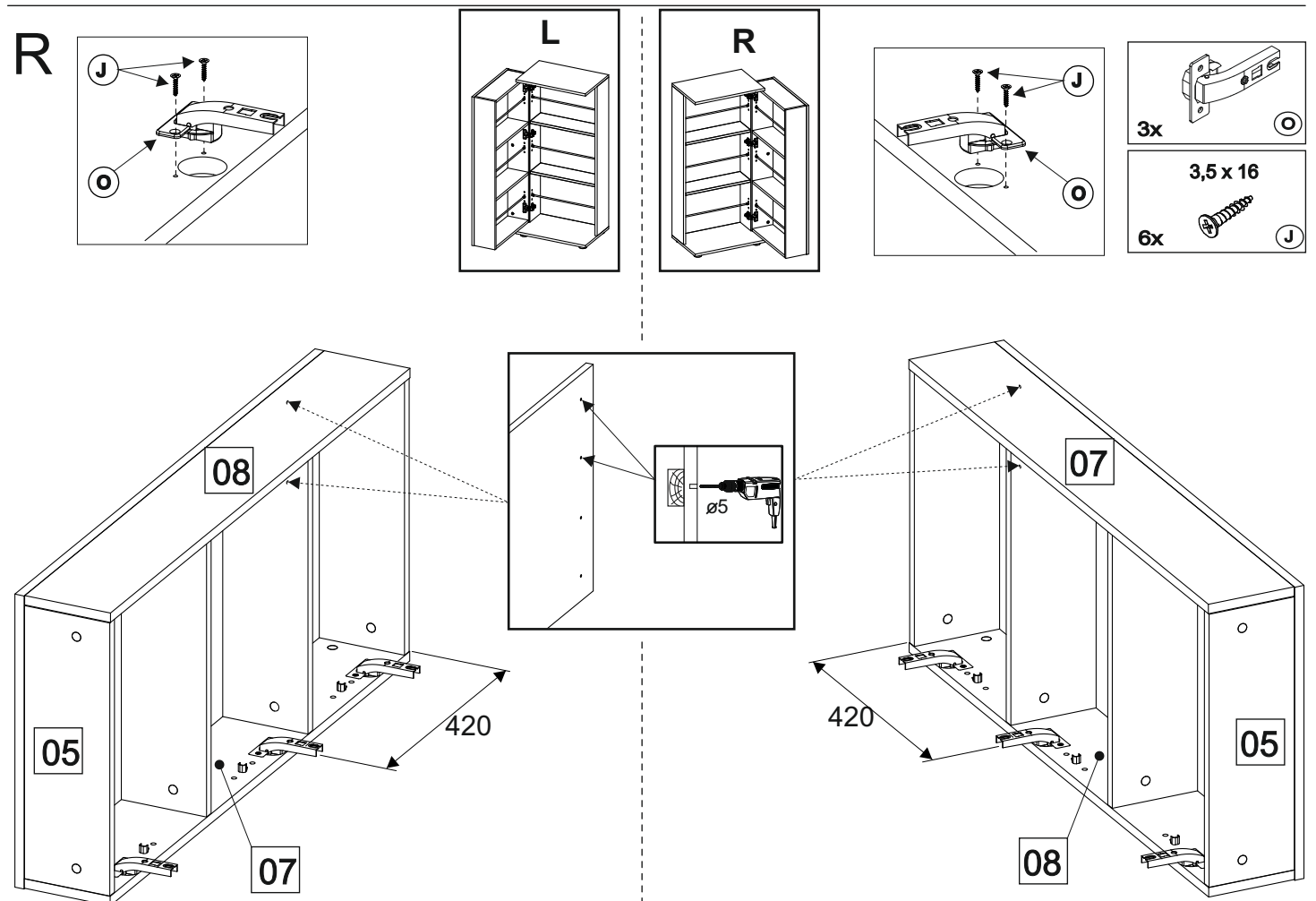
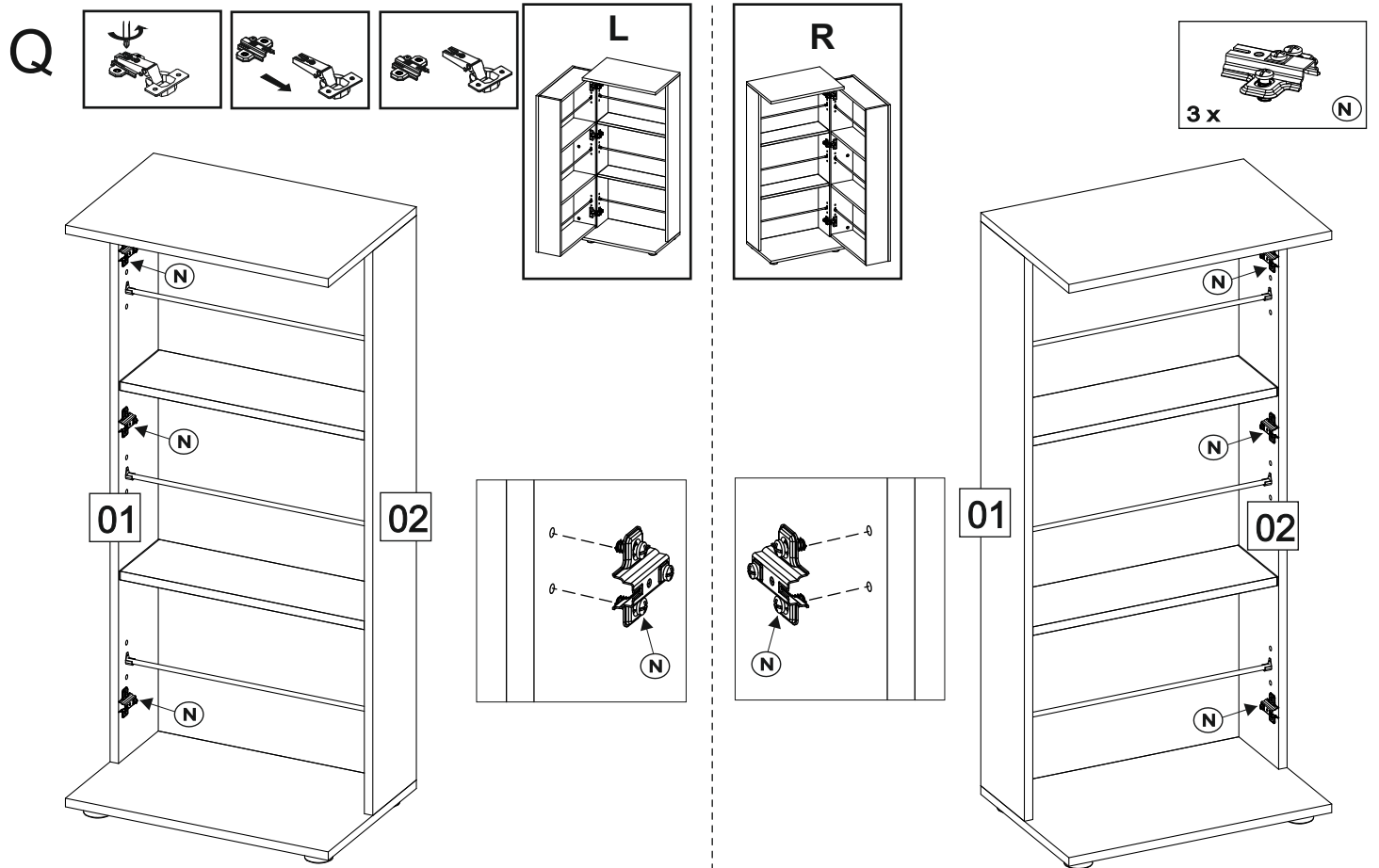

S

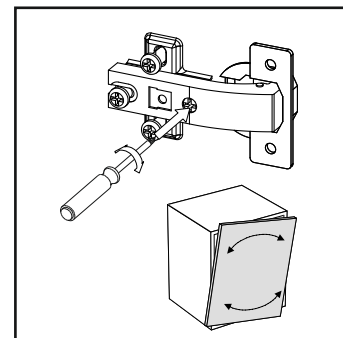
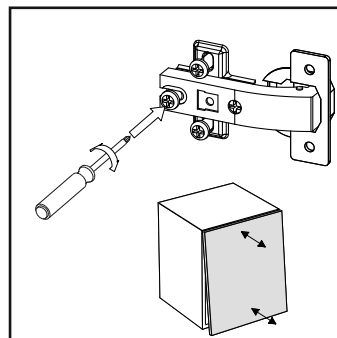
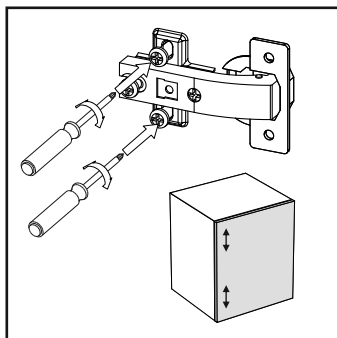
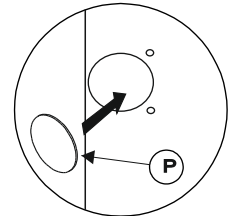
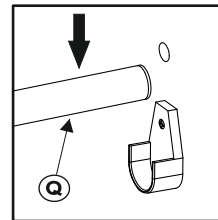
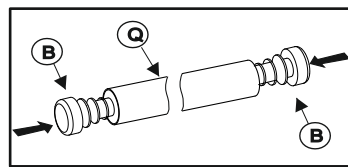
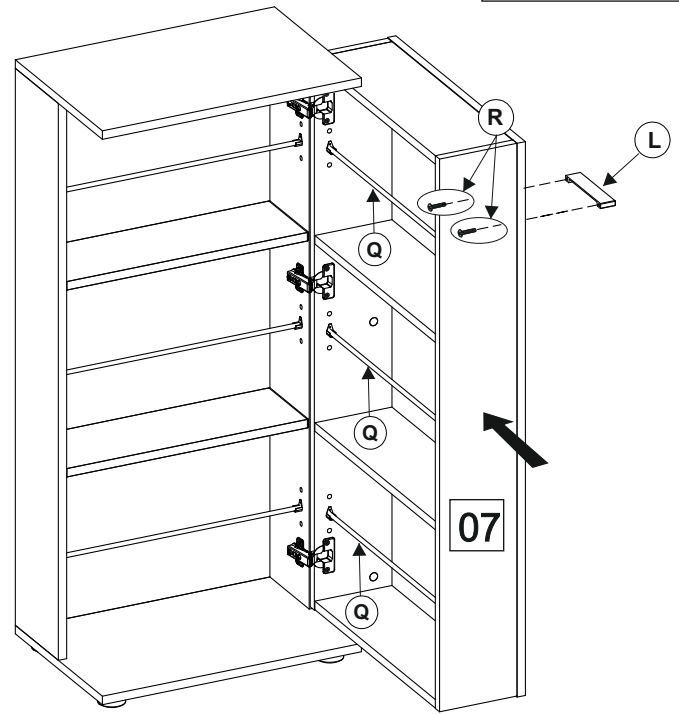
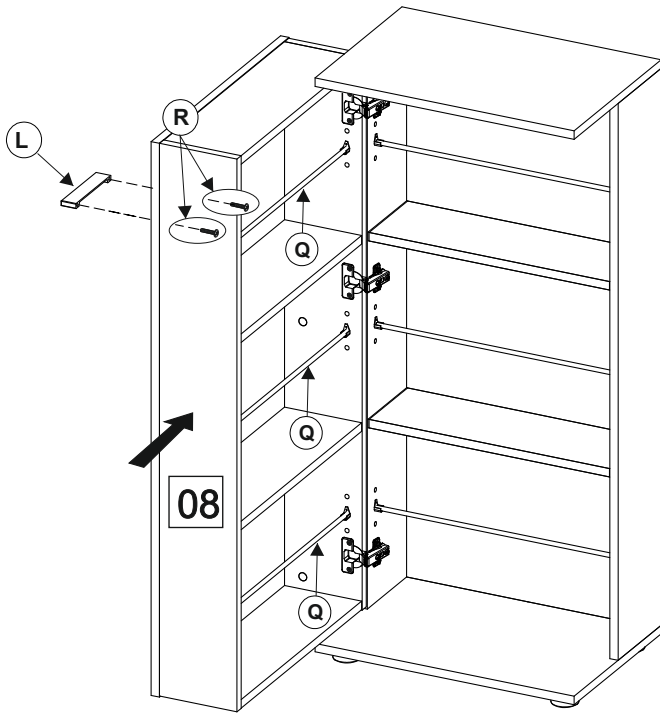
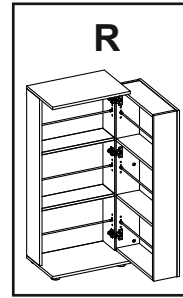
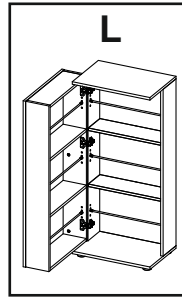
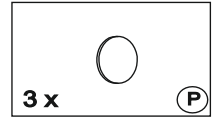
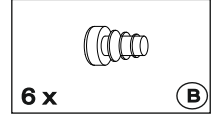
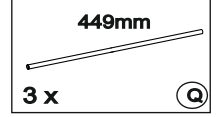
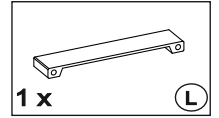
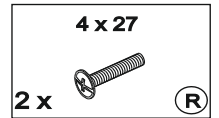
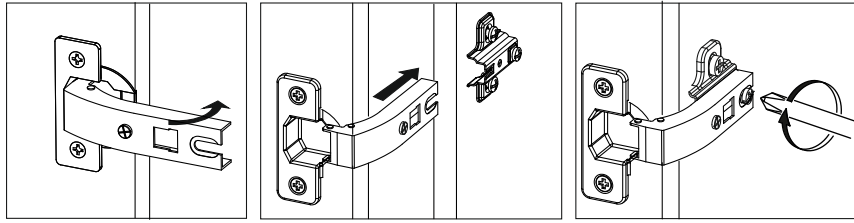



- (D) Das Möbel muss an der Wand befestigt werden!
- (GB) Please ensure to mount the furniture to the wall!
- (FR) Les meubles doivent être fixés au mur!
- (NL) Het meubel moet aan de wand worden vastgemaakt!
- (ES) El mueble se tiene que fijar a la pared!
- (PL) Mebel należy przymocować do ściany!

- (RU) Мебель должна крепиться к стене!
- (IT) Il mobile deve essere fissato alla parete!
- (HU) A bútor a falon rögzítendő!
- (P) O móvel tem que ser fixado na parede!
- (CZ) Nábytek musí být připevněn ke stěně!
- (SK) zverte kvalifikovanej ozone!



- (D) Informieren Sie sich vor der Wandmontage über das geeignete Montagematerial!
- (GB) Please get informed on suitable assembly materials before commencing the wall-mounting!
- (FR) Renseignez-vous sur le matériel de montage approprié avant le montage mural!
- (NL) Informeer u voor de wandmontage over het geschikte montagematerieel!
- (ES) Infórmese antes del montaje en la pared del material apropiado de montaje!
- (PL) Przed montażem na ścianie upewnij się, jaki jest potrzebny właściwy materiał montażowy!

- (RU) Перед тем, как крепить мебель к стене, получите информацию о подходящем крепежном материале!
- (IT) Prima del fissaggio alla parete, informarsi sul materiale di montaggio adatto!
- (HU) A falra szerelés előtt tájékozódjon, hogy ehhez milyen szerelőanyagok szükségesek!
- (P) Antes da montagem na parede, informe-se sobre o material de montagem adequado!
- (CZ) Informujte se o vhodném montážním materiálu před montáží na stěnu!
- (SK) Pred montážou na stenu sa informujte o vhodnom montážnom materiáli!



- (D) Beschaffen Sie sich das angemessene Material zur Wandbefestigung!
- (GB) Please obtain suitable wall-mounting materials!
- (FR) Procurez-vous le matériel approprié pour le montage mural!
- (NL) Verschaf u het adequate materieel voor de wandbevestiging!
- (ES) Procúrese el material adecuado para la fijación a la pared!
- (PL) Zakup odpowiedni materiał do przymocowania na ścianie!

- (RU) Приобретите соответствующий материал для крепления к стене!
- (IT) Procurarsi il materiale opportuno per il fissaggio alla parete!
- (HU) Szerezze be a falra szereléshez szükséges, megfelelő anyagokat!
- (P) Obtenha o material adequado para a montagem na parede!
- (CZ) Opatřte si vhodný materiál pro montáž na stěnu!
- (SK) Zabezpečte si vhodný materiál na montáž na stenu!



- (D) Lassen Sie die Wandbefestigung von einer fachkundigen Person vornehmen!
- (GB) Ensure all wall-mounting is carried out by competent personnel!
- (FR) Faites effectuer le montage mural par une personne compétente!
- (NL) Laat de wandbevestiging door een professional uitvoeren!
- (ES) Deje que la fijación a la pared la haga un profesional!
- (PL) Zleć przymocowanie do ściany odpowiednio doświadczonej osobie!

- (RU) Поручите выполнение работ по креплению к стене специалисту!
- (IT) Far effettuare il fissaggio alla parete ad un esperto!
- (HU) A bútor falra rögzítését végeztesse ehhez értő személlyel!
- (P) A montagem na parede deve ser executada por uma pessoa competente!
- (CZ) Montáž na stěnu nechte provést odborně způsobilou osobou!
- (SK) Montáž na stenu zverte kvalifikovanej osobe!

