

# ASSEMBLY INSTRUCTION

## 430 - 313/316 AFFINITY UPH BED HEADBOARD

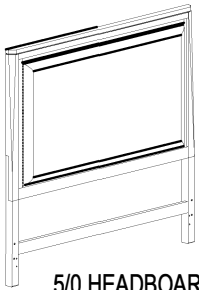

5/0 HEADBOARD

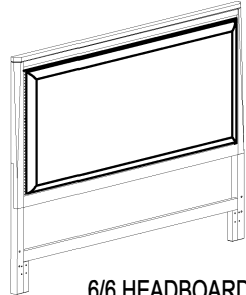

6/6 HEADBOARD

3) Assembly is completed.

### IMPORTANT NOTES :

- . Place all wooden parts on a clean and smooth surface such as a rug or carpet to prevent the parts from being scratched.
- . Check to be sure that you have all parts and hardware.
- . Remove all wrapping materials, including staples and packing straps before you start to assemble.
- . Do not tighten all screws and bolts until completely assembled.
- . Keep all hardware out of the reach of children.

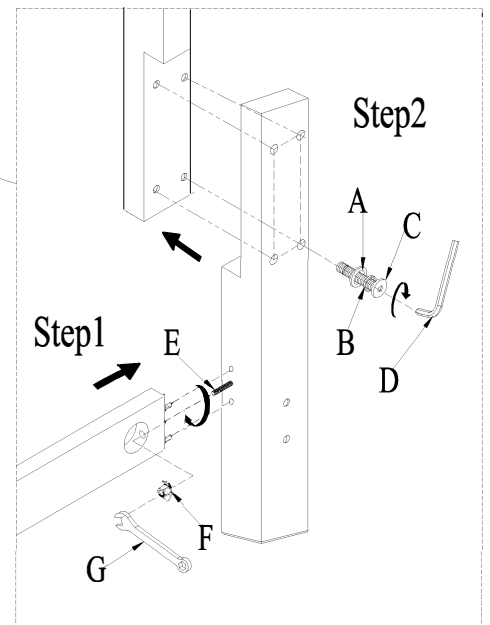
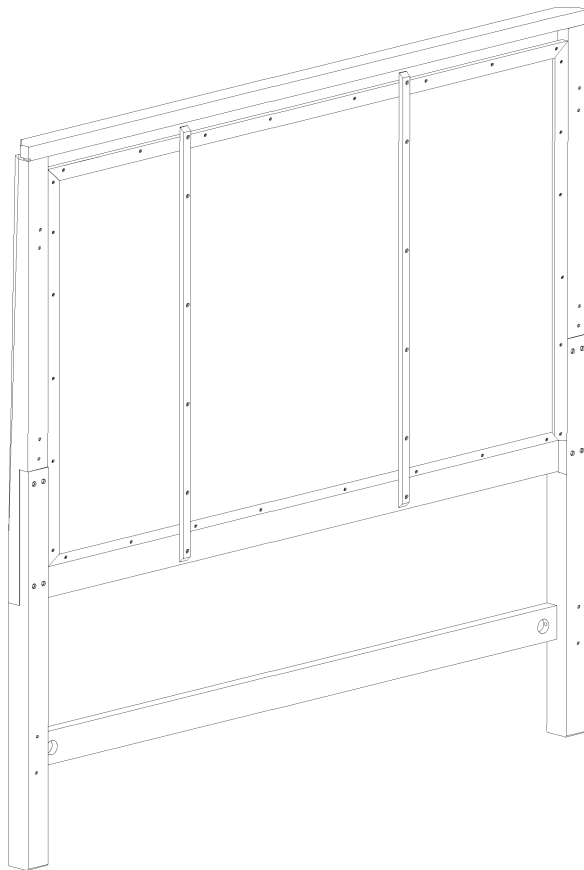

NO.	Dimension	Shape	Quantity
A	Flat Washer Ø5/16"*19mm		8pcs
B	Lock Washer Ø5/16"		8pcs
C	Bolt 5/16"*45mm		8pcs
D	Allen Key 4mm		1pc
E	Thread Rod 5/16"*88mm		2pcs
F	Curved Slotted Washer 5/16"		2pcs
G	Wrench 12mm		1pc

## ASSEMBLY INSTRUCTION

430-313/314 5/0 AFFINITY UPH BED - HDBD - FTBD - W/RAILS

430-316/317 6/6 AFFINITY UPH BED - HDBD - FTBD - W/RAILS

430-316/318 6/0 AFFINITY UPH BED - HDBD - CAL FTBD - W/RLS

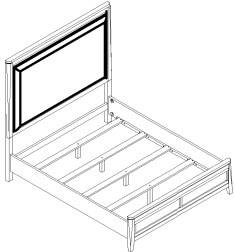

5/0 HDBD-FTBD W/RAILS

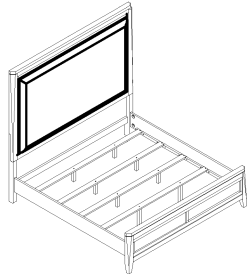

6/6 HDBD-FTBD W/RAILS

6/0 HDBD-CAL FTBD W/RLS

4) Assembly is completed.

## IMPORTANT NOTES :

- . Place all wooden parts on a clean and smooth surface such as a rug or carpet to prevent the parts from being scratched.
- . Check to be sure that you have all parts and hardware.
- . Remove all wrapping materials, including staples and packing straps before you start to assemble.
- . Do not tighten all screws and bolts until completely assembled.
- . Keep all hardware out of the reach of children.

