

PLASTIC GARDEN SHED PP8X8Z

Instructions for Assembly

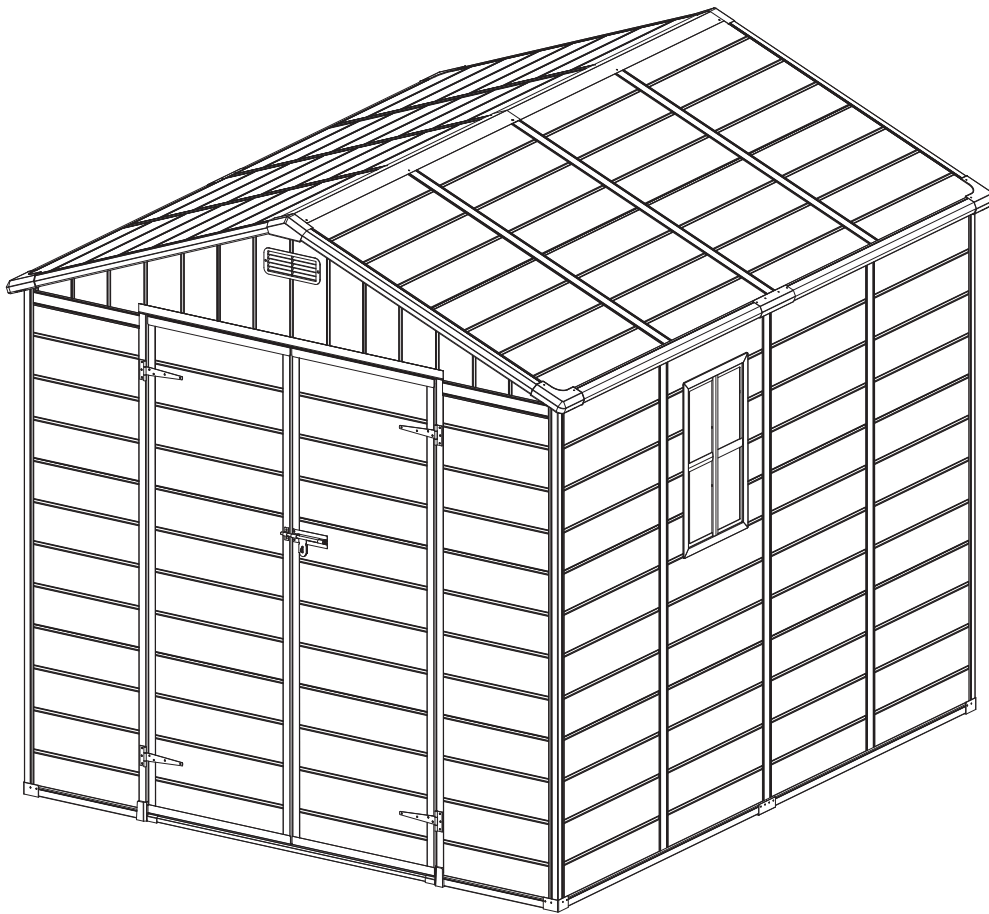

WARNING

Please read the instruction manual carefully before assembly.
Please assembly strictly in accordance with the instruction.
Please double-check to ensure that all parts of the package contents intact.
To avoid injury, work gloves are recommended during assembly.

SITE PREPARATION | PRÉPARATION DU SITE | PREPARACIÓN DEL LUGAR | VORBEREITUNG DES AUFSTELLUNGORTES | VOORBEREIDING VAN HET TERREIN | PREPARAZIONE DEL LUOGO DI ASSEMBLAGGIO | PREPARAÇÃO DO LOCAL

Level the ground surface | Nivelez la surface du sol | Nivela la superficie del suelo | Ebnen Sie die Bodenoberfläche | Maak de bodem vlak | Livellare la superficie del terreno | Nivela a superfície do solo

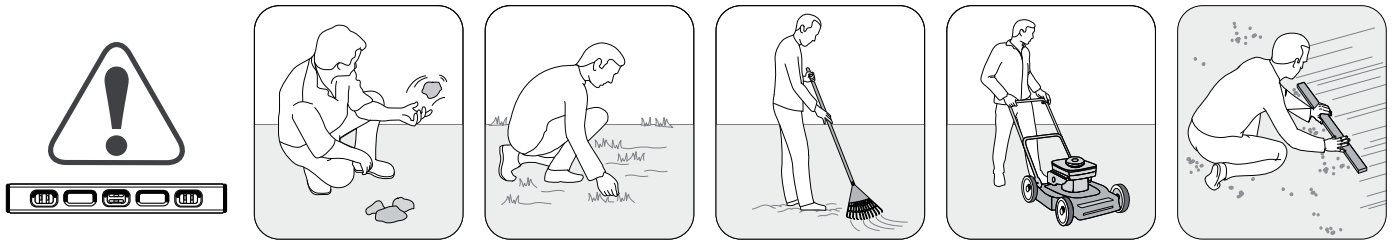

Recommendation: Construct a wooden or concrete base as a foundation | Recommandation: fabriquez une base en bois ou en béton en guise de fondation | Recomendación: construya una base de madera o de cemento a modo de cimiento | Empfehlung: Bauen Sie als Fundament eine Grundfläche aus Holz oder Beton | Aanbeveling: maak een houten of betonnen ondergrond als fundering | Raccomandazione: Costruire una base di legno o di cemento come fondamenta | Recomendação: Construa uma base de madeira ou de cimento como fundação

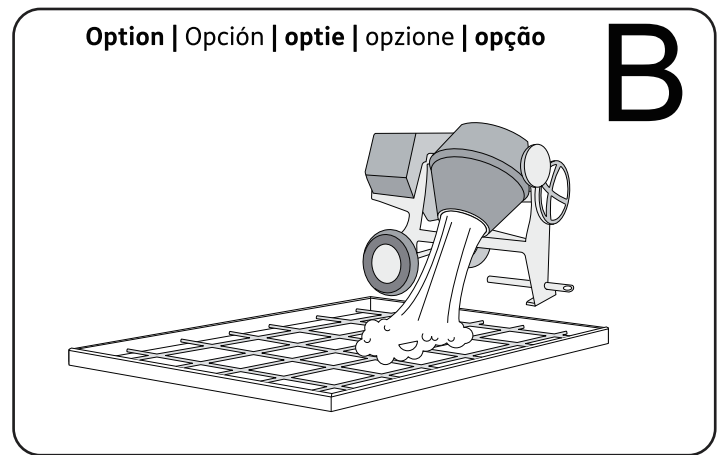
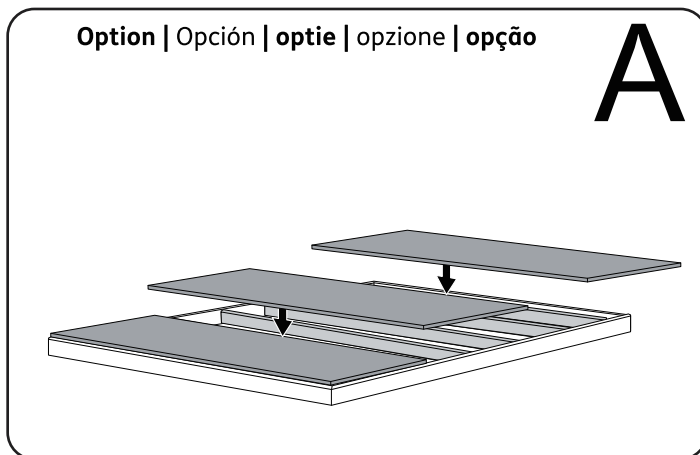

External floor measurements are: | Les mesures externes de la étage sont: | Las medidas del suelo externo son: | Die Außen-Bodenmaße betragen: | De afmetingen van de externe vloer zijn: | Le dimensioni esterne del pavimento sono: | As medidas externas do chão são:

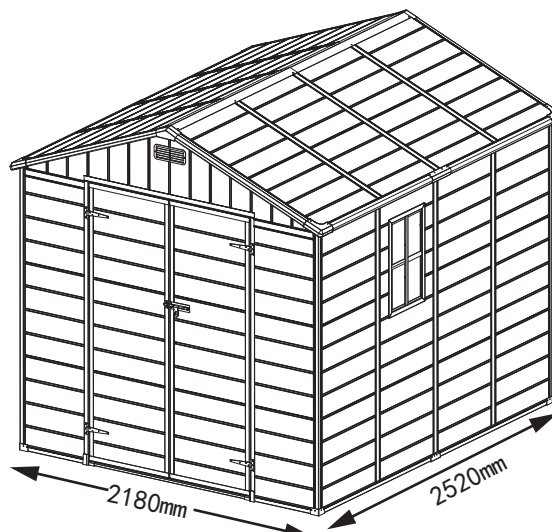

BEFORE STARTING ASSEMBLY | AVANT DE COMMENCER LE MONTAGE | ANTES DE EMPEZAR EL ARMADO | VOR MONTAGEBEGINN | VOORDAT U BEGINT TE MONTEREN | PRIMA DI INIZIARE L'ASSEMBLAGGIO | ANTES DE INICIAR A MONTAGEM

Read the care and safety guidelines at the end of this manual | Check to ensure that there are no missing or damaged parts BEFORE starting or arranging assembly | Remove all parts from the package(s) and spread them out on a clean work surface | Review all assembly instructions | Assemble all the parts according to the directions in this manual. Do not skip any steps.

Lisez les instructions de précaution et de sécurité à la fin de ce manuel | Assurez-vous qu'il n'y a pas de pièces manquantes ou endommagées AVANT de commencer ou d'organiser l'assemblage | Retirez toutes les pièces du/des paquet(s) et étalez-les sur une surface de travail propre | Lisez toutes les instructions de montage | Assemblez toutes les pièces selon les instructions de ce manuel. Ne sautez aucune étape.

Lea las intrucciones de precauciones y seguridad que están al final de este manual | Asegúrese de que no faltan piezas ni están dañadas ANTES de comenzar o disponer el montaje | Saque todas las piezas del paquete o paquetes y póngalas sobre una superficie de trabajo limpia | Revise todas las instrucciones de montaje | Monte todas las piezas según las instrucciones de este manual. No se saltee ningún paso.

Lesen Sie die Sicherheitsrichtlinien am Ende des Benutzerhandbuchs durch | Prüfen Sie bitte VOR dem Zusammenbau, dass keine Teile beschädigt sind oder fehlen | Nehmen Sie alle Teile aus der Verpackung und breiten Sie sie auf einer sauberen Arbeitsfläche aus | Gehen Sie noch einmal die komplette Aufbauanleitung durch | Bauen Sie alle Teile entsprechend der Anleitung in diesem Handbuch zusammen. Lassen Sie dabei keinen Arbeitsschritt aus.

Lees de richtlijnen voor zorg en veiligheid achterin deze handleiding | Controleer dat er geen onderdelen mankeren, of beschadigd zijn, VOORDAT u met de montage begint | Haal alle onderdelen uit het pakket (of uit de pakketten) en leg ze open schoon werkoppervlak | Bekijk alle montagehandleidingen | Monteer alle onderdelen volgens de aanwijzingen van deze handleiding. Sla geen stappen over.

Leggere le linee guida di assistenza e sicurezza alla fine di questo manuale | Assicurarsi che non ci siano parti mancanti o danneggiate PRIMA di iniziare l'assemblaggio | Estrarre tutti i componenti dall'imballo e posizzarli su una superficie di lavoro pulita | Consultare tutte le istruzioni di montaggio | Assemblare tutti i componenti secondo le istruzioni contenute nel manuale. Non saltare nessuna fase.

Leia as diretrizes de cuidados e segurança que constam da parte final deste manual | Verifique para se assegurar de que não há peças em falta ou danificadas ANTES de começar a preparar a montagem | Retire todas as peças da embalagem e espalhe-as numa superfície de trabalho limpa | Reveja todas as instruções de montagem | Monte todas as peças de acordo com as instruções do manual. Não salte quaisquer passos.

REQUIRED TOOLS | OUTILS EXIGÉS | HERRAMIENTAS NECESARIAS | BENÖTIGTE WERKZEUGE | BENODIGD GEREEDSCHAP | ATTREZZATURA OCCORRENTE | FERRAMENTAS NECESSÁRIAS

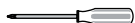

SPATULA | SPATULE | ESPÁTULA | SPACHTEL | SPATEL | SPATOLA | ESPÁTULA

- Use spatula (part "SG8") for easier insertion of panel into profile.
- Utilisez la spatule (partie "SG8") pour une meilleure insertion du panneau dans le profil.
- Utilice una espátula (pieza "SG8") para una mejor inserción del panel en el perfil.
- Benutzen Sie den Spachtel (Bezeichnung "SG8"), um die Platten leichter in die Nut einführen zu können.
- Gebruik spatel (onderdeel SG8) voor het gemakkelijk invoeren van het paneel in het profiel.
- Utilizzare la spatola (parte SG8) per inserire il pannello più facilmente nel profilo.
- Utilize uma espátula (peça "SG8") para facilitar a inserção do painel no perfil.

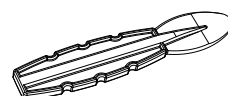



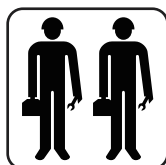





















































SG8 x2































ASSEMBLY REQUIRES TWO PEOPLE | LE MONTAGE DOIT ÊTRE EFFECTUÉ PAR DEUX PERSONNES | SE NECESITAN DOS PERSONAS PARA ARMARLO | ZWEI PERSONEN ZUR MONTAGE NOTWENDIG | MONTAGE VEREIST TWEЕ PERSONEN | L'ASSEMBLAGGIO RICHIEDE DUE PERSONE | A MONTAGEM EXIGE DUAS PESSOAS

PARTS LIST

NO.	PART.	Qty.
QF1-2		4
QF1-1		12
QP6		4
QP1		2
QP3		2
DP4		1
QP8		6
SG19		3
SG6		4
SG7-1		1
SG7-2		1
QW1-2		2
QW1-3		2
QW1-1		20
QW2-2		2
QW2-1		4
QW3-1		4
QW3-2		2
QT1-1		1
QT1-2		1
QT1-3		1
QT1-4		1
QT1-5		1
QT1-6		1
QT1-7		1
QT1-8		1
QT1-9		1
QT1-10		1

NO.	PART.	Qty.
DP5		4
PS1		6
PPA1		6
QAP1		2
PPA2		1
QAP3		2
QA3		1
DA1L		1
DA1R		1
SS4		1
SS3		1
SS6		1
PS5		2
QS2		1
BY		2
SG27		2
SG14		4
SG10		2
SG101		2
SG102		2
QR1-2		8
QR1-1		8
QP7		4
QP4		4
QAP2		6
CS2-2		6
CS4-1		3
8-1		2

NO.	PART.	Qty.
8-2		2
SG1		2
SG2		4
DD1-1		1
DD1-2		1
DD1-3		1
DD1-4		1
DD1-5		1
DD1-6		1
DA4		2
DS1		2
DA1		1
DA2		1
DA2R		1
DA2L		1
SG9		5
SG8		2
M01		4
M03-6L		1
M03-7		1
M04		1
Drill		1
DC		2
Z410		203
Z420		182
ZW413		102
Z425		4
RF7		4
SG20		2



- Use spatula  (part "SG8") for easier insertion of panel into profile.
- Please ensure the panels are all installed on position before screwing.
- Please be mindful of the screw size used during installation; using screws that are too long may damage the shed.

FLOOR ASSEMBLY

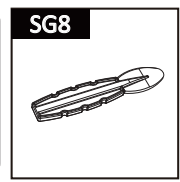
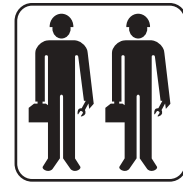
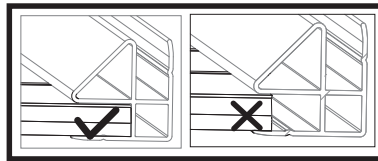

● Fully fit the panel inside the profile

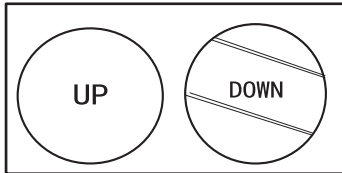

● The crease line of the floor must be underneath

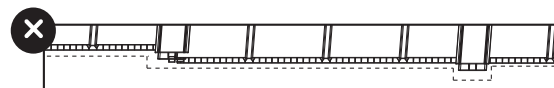
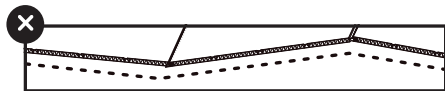
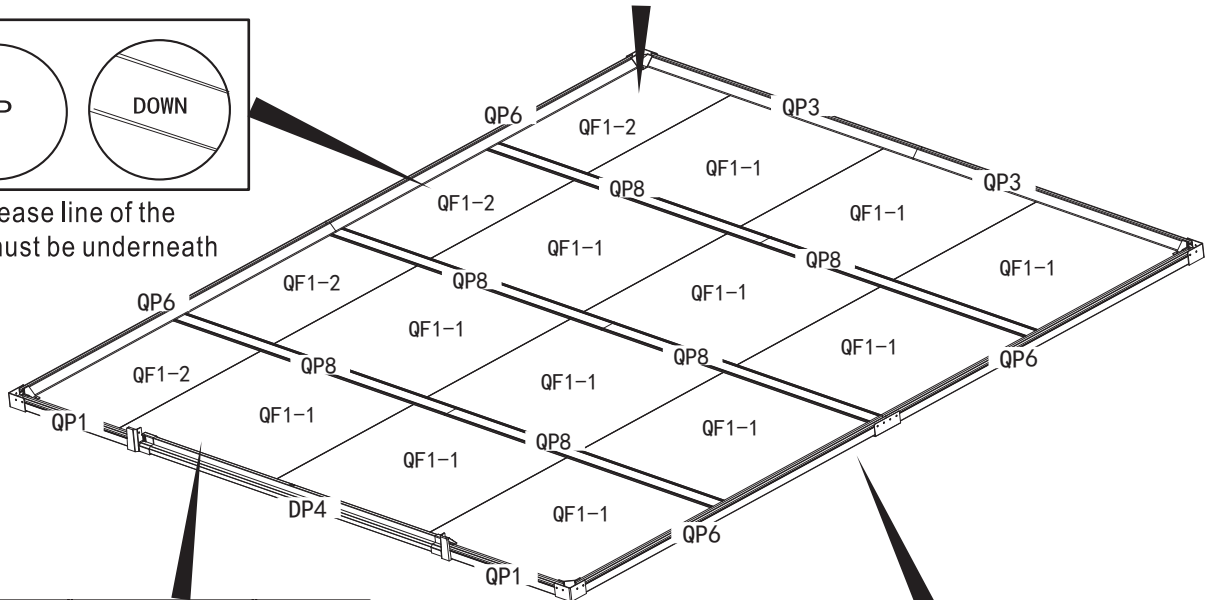

When installing the floor, when the textured face up to have the floor installed in a flat state.

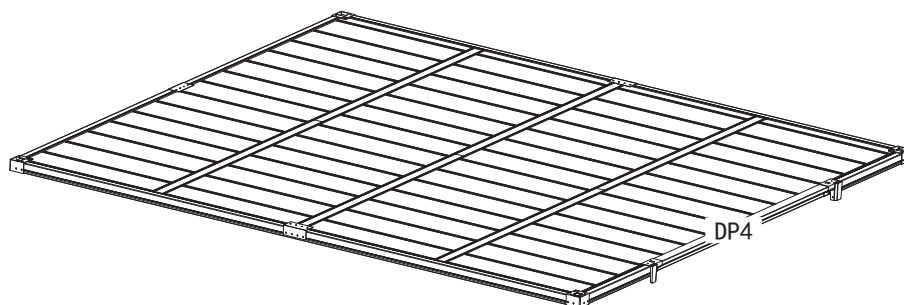
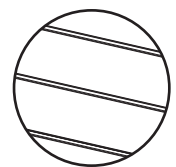

Step 1

1-1

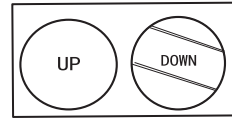
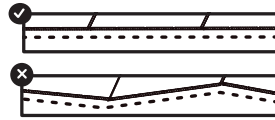
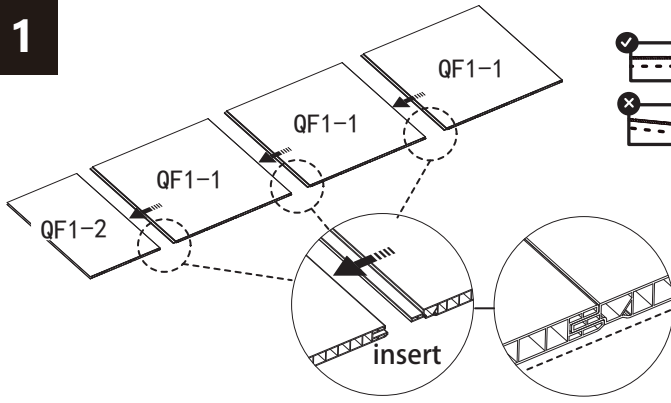

• The crease line of the floor must be underneath

SG8



QF1-1

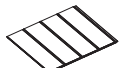

3 PC

QF1-2

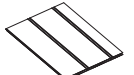

1 PC

1-2

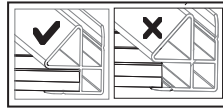
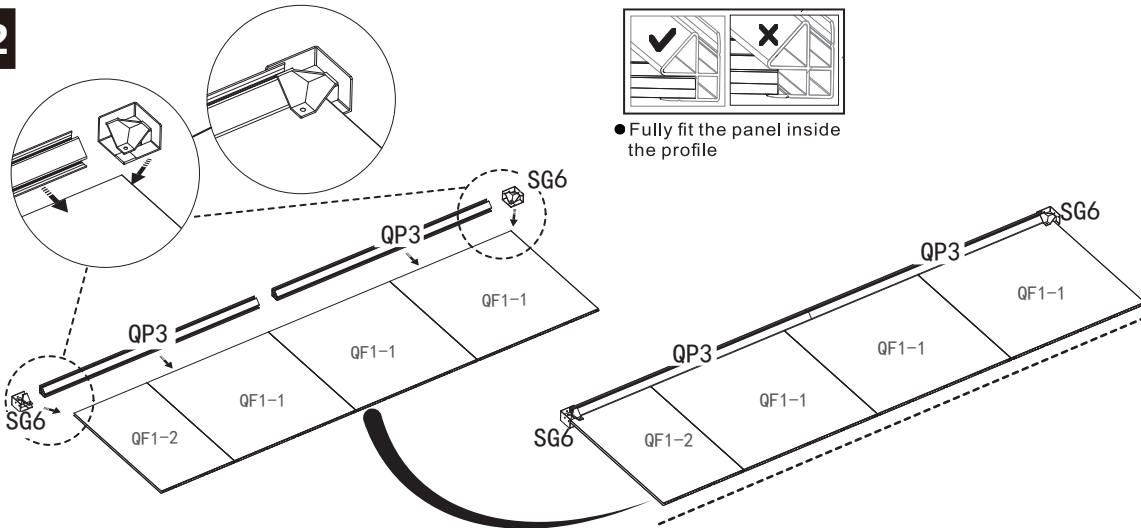

• Fully fit the panel inside the profile

QP3



2 PC

SG6



2 PC

Step 2

2-1

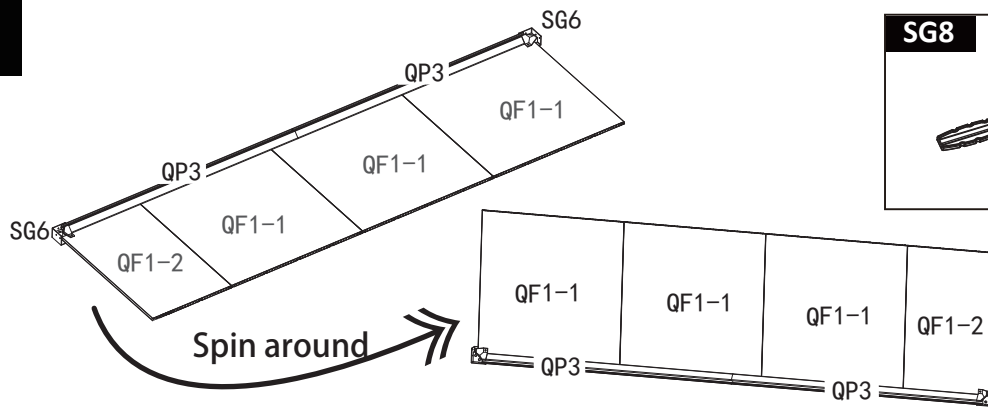

SG8



QP6



1 PC

QP8



2 PC

2-2

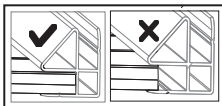

• Fully fit the panel inside the profile

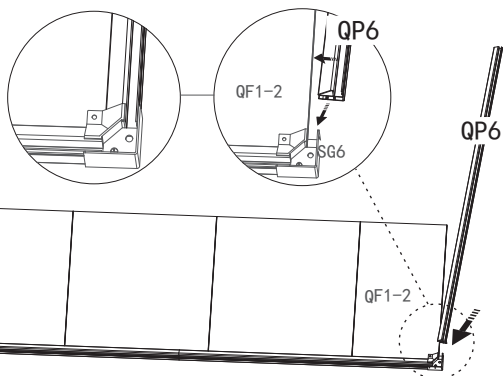

2-3

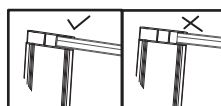

• Fully fit the panel inside the profile

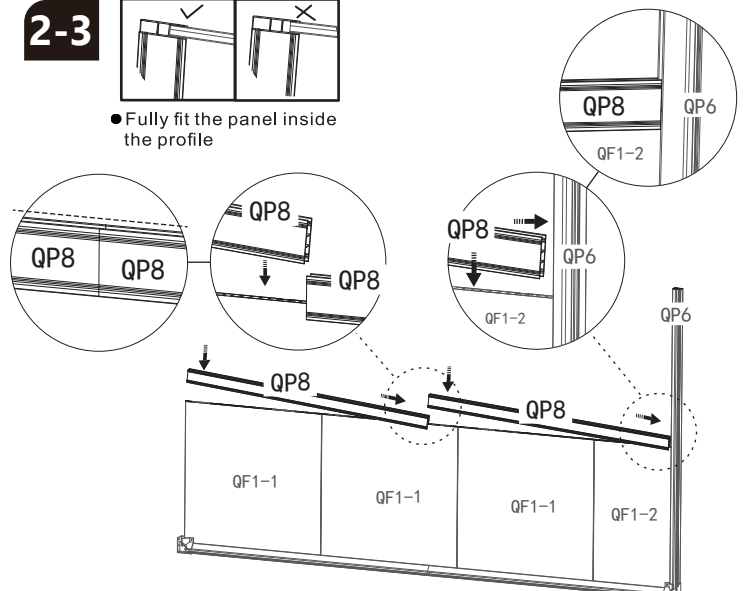

Step 3

Pay attention to the direction of the board

3-1

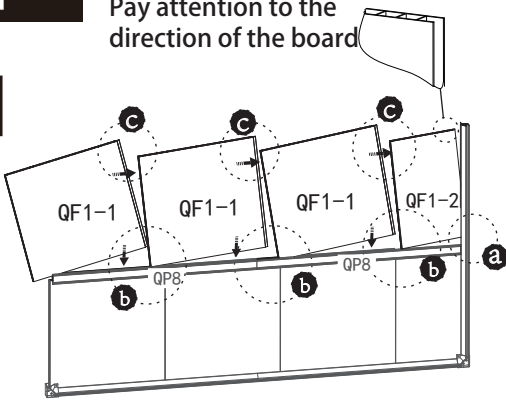

3-2

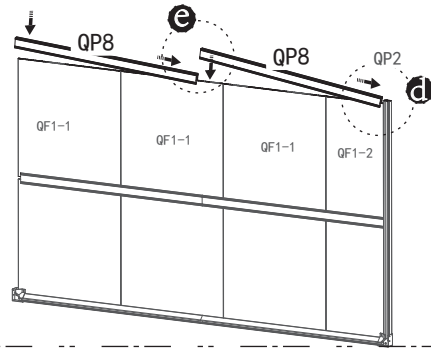

3-3

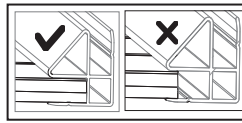
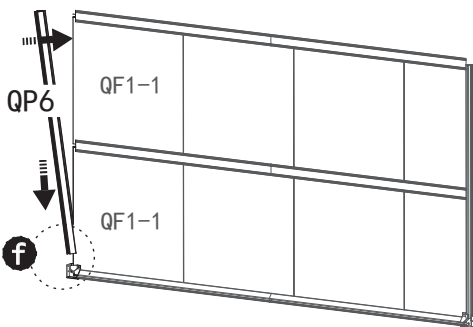

● Fully fit the panel inside the profile

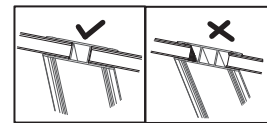

● Fully fit the panel inside the profile

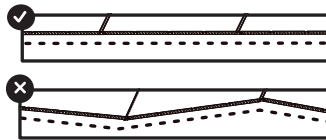

QF1-1

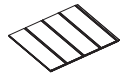

3 PC

QF1-2

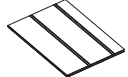

1 PC

QP8



2 PC

QP6



1 PC

SG8

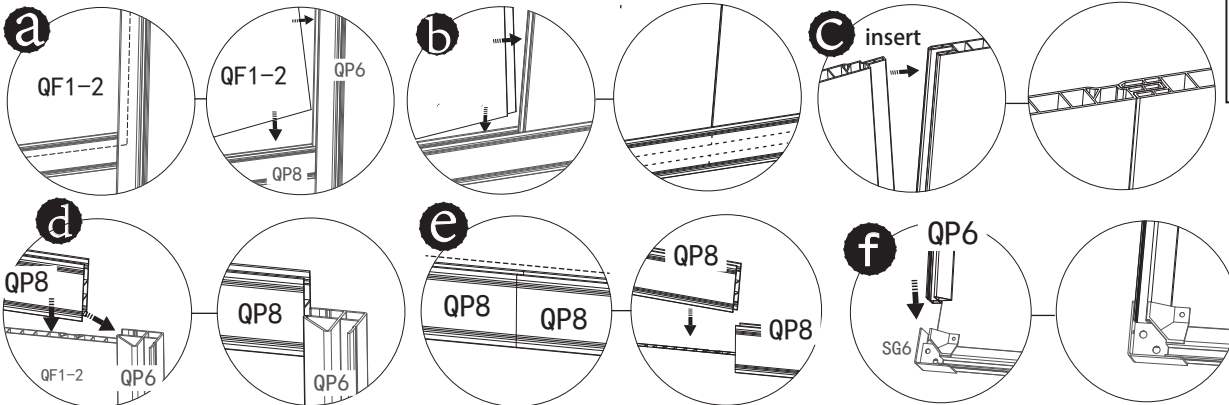

3-4

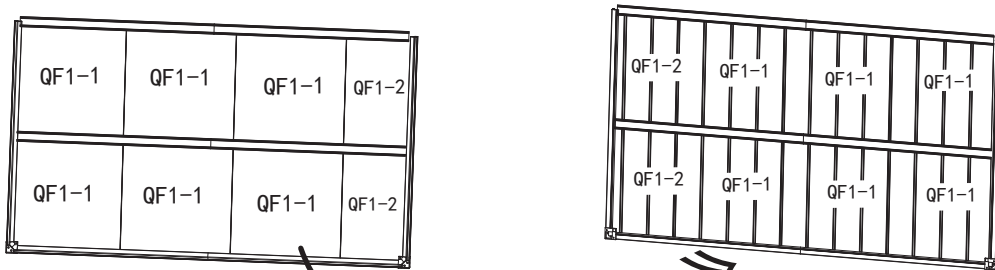

Spin around

3-5

$ab=cd$

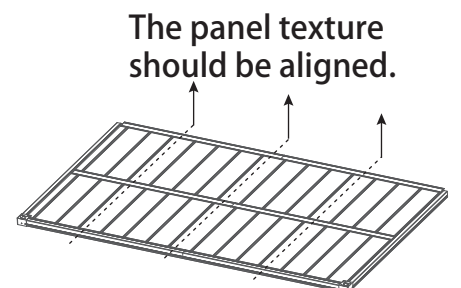
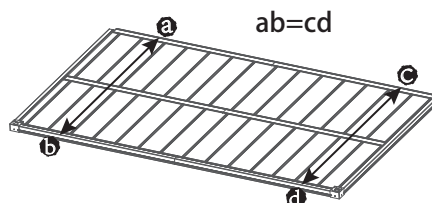
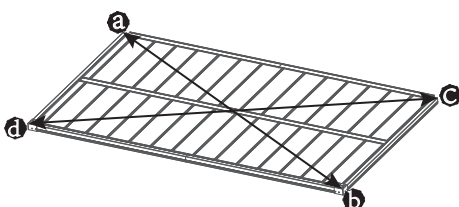

Step 4

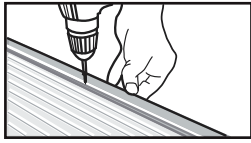

Screw along the marked lines in profile

Caution: Please use Drill  to predrill a hole at depth 1mm before screw.



SG19

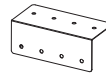

1 PC

Z410



12 PC

Z420



16 PC

4-1

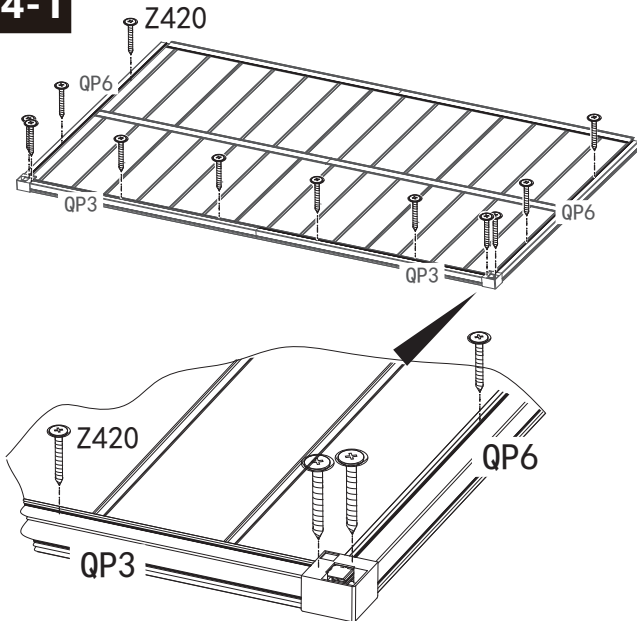

4-2

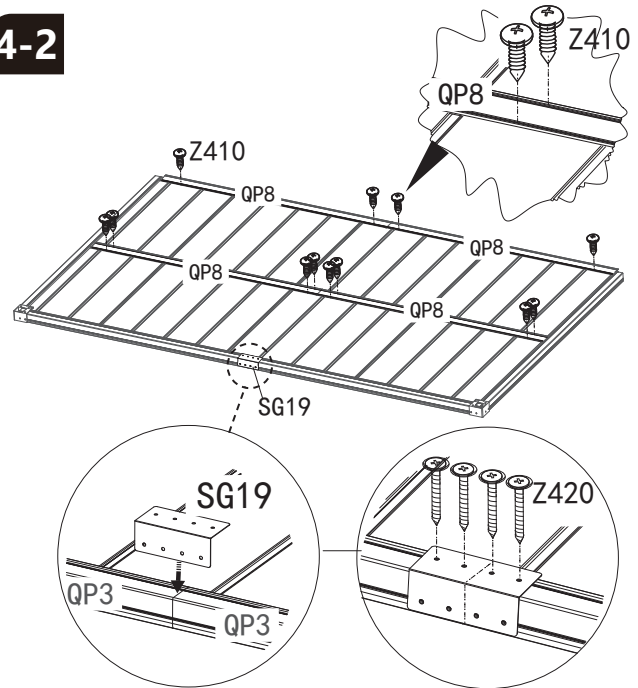

Step 5

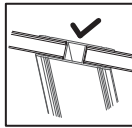

● Fully fit the panel inside the profile

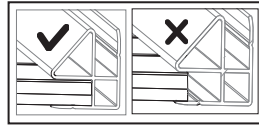
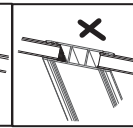

● Fully fit the panel inside the profile

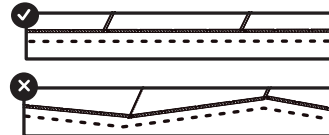

5-1

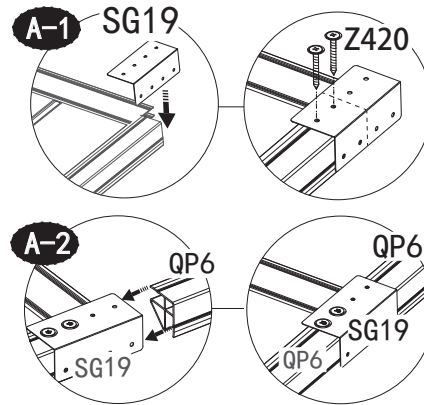
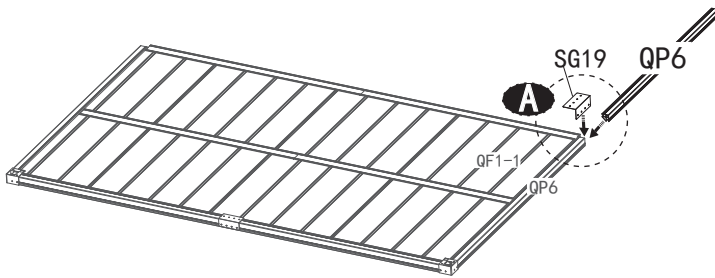

QP6



1 PC

SG19

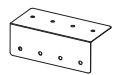

1 PC

Z420



2 PC

QF1-1

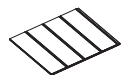

3 PC

QF1-2

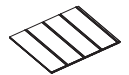

1 PC

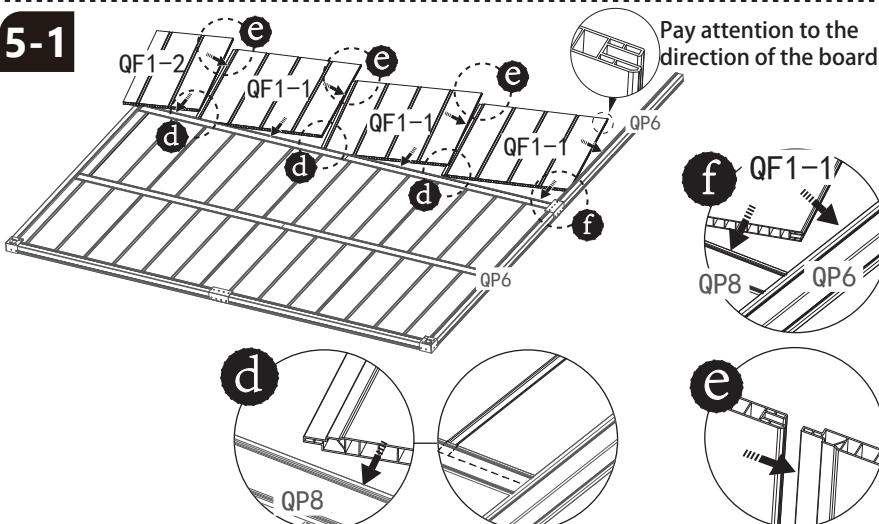

5-1

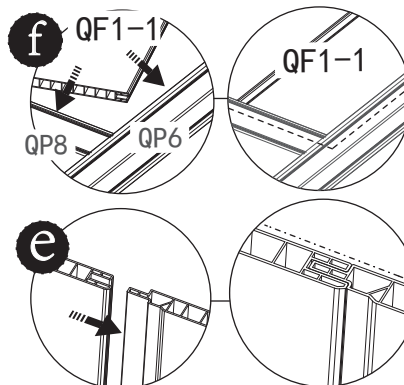

Pay attention to the direction of the board

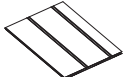
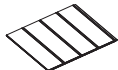

Step 6

QP6  1 PC	QF1-2  1 PC	QF1-1  3 PC	QP8  2 PC	SG8 
---	---	---	--	---

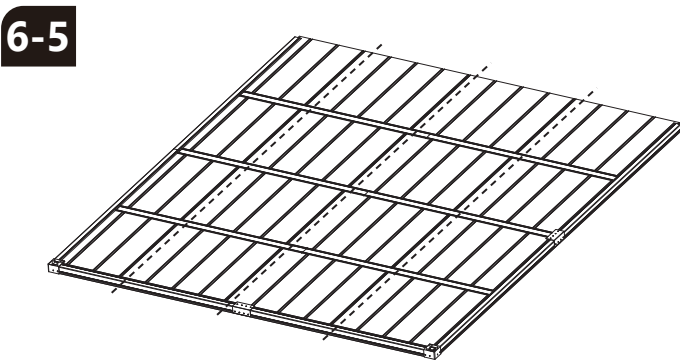
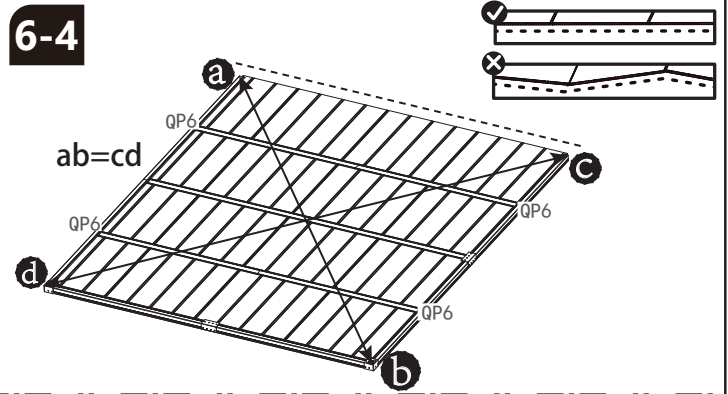
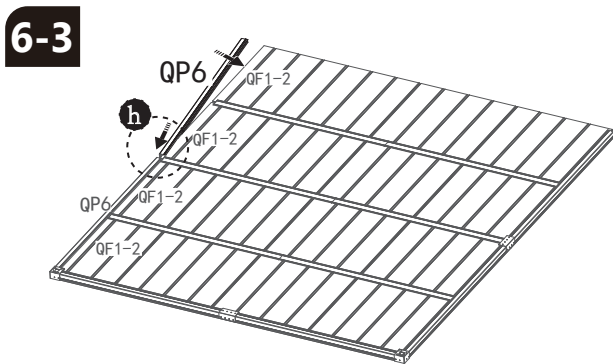
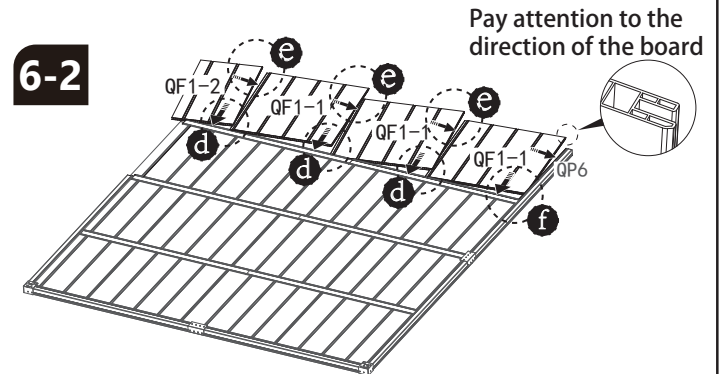
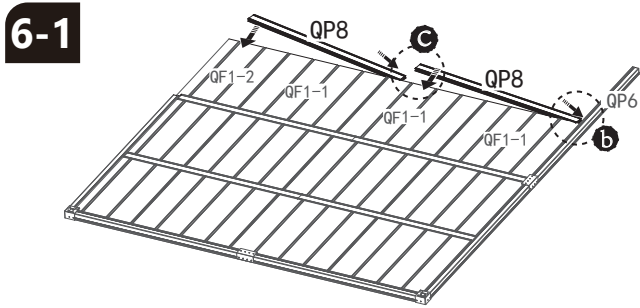

The panel texture should be aligned

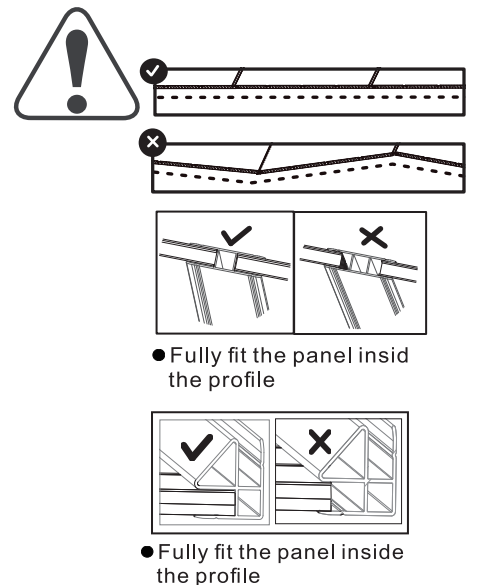
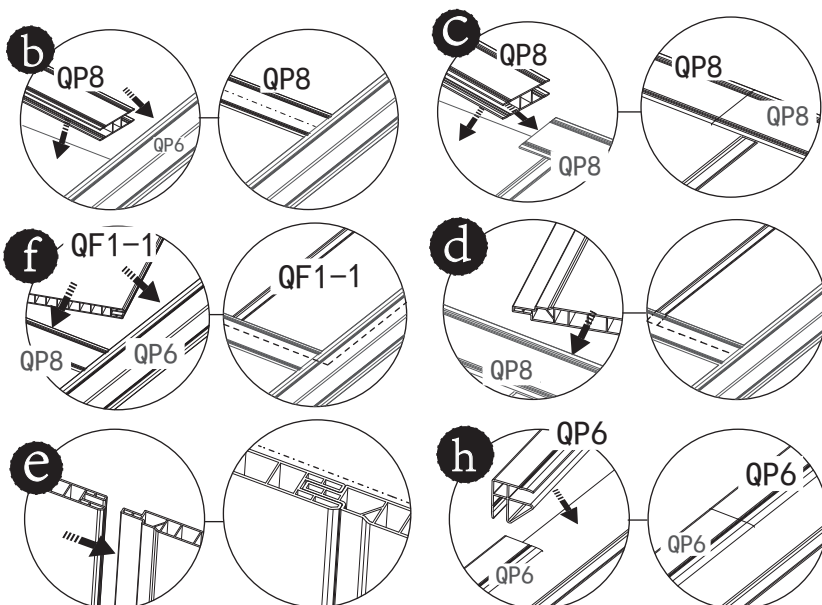
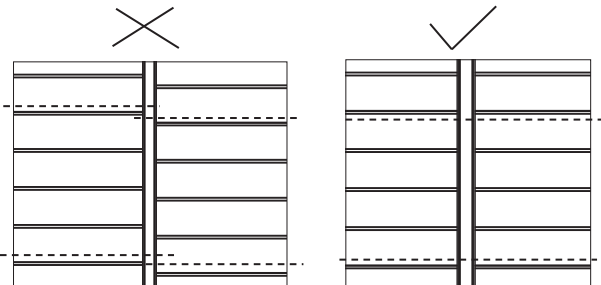

Step 7

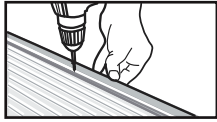

Screw along the marked lines in profile

Caution:
Please use Drill  to predrill a hole at depth 1mm before screw.

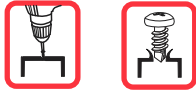

SG19

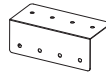

1 PC

Z410



12 PC

Z420



10 PC

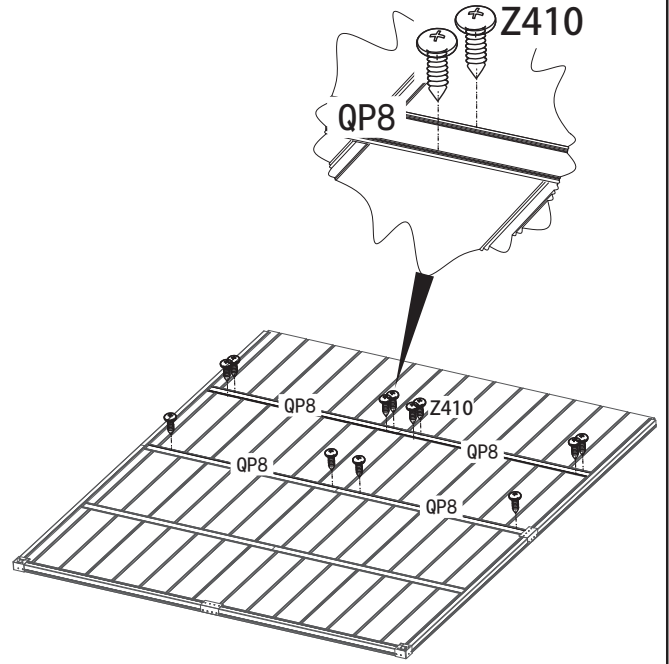
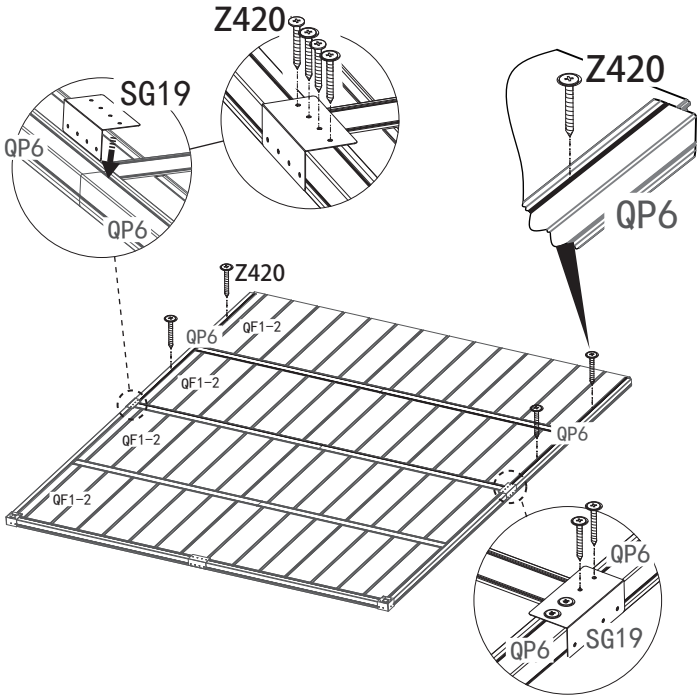

Step 8

SG8



SG7-2



1 PC

DP4

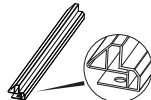

1 PC

SG7-1



1 PC

QP1



2 PC

SG6



2 PC

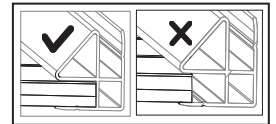
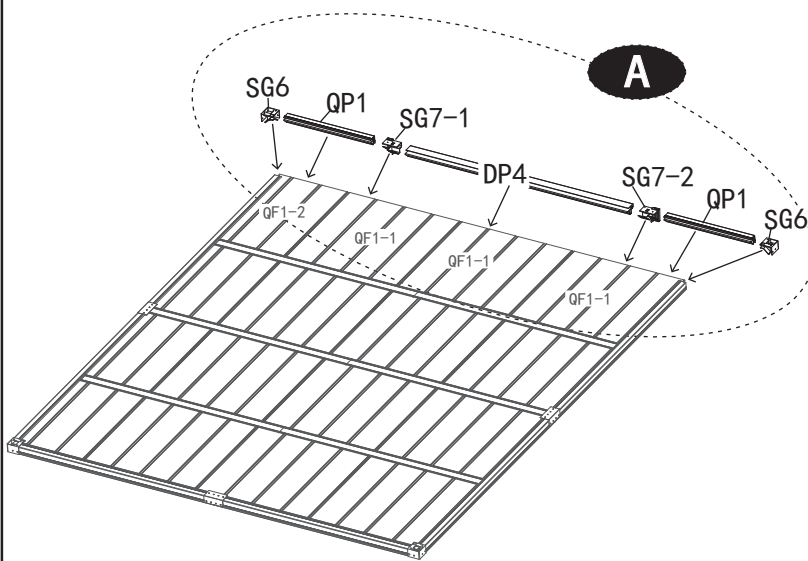

● Fully fit the panel inside the profile

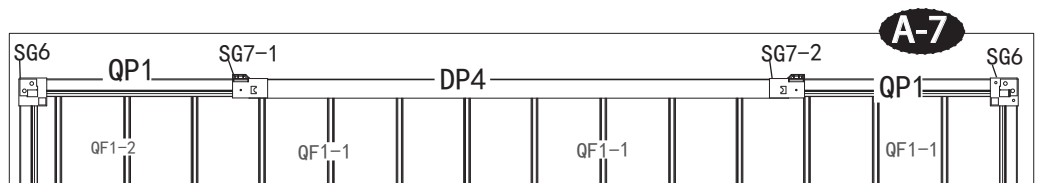
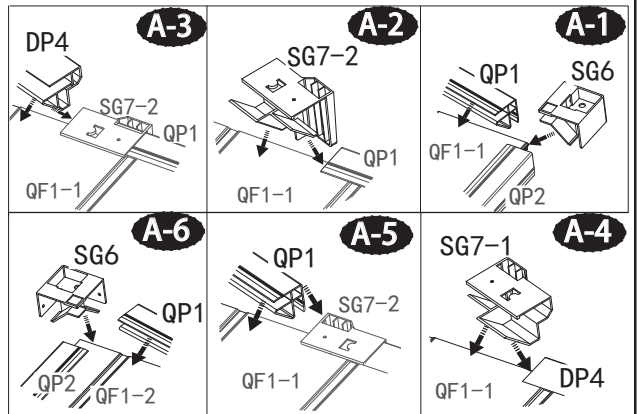

Step 9

9-1

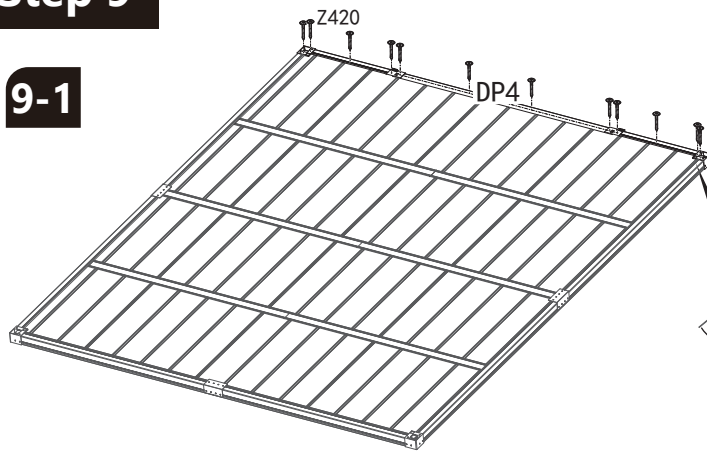

Caution: Please use Drill to predrill a hole at depth 1mm before screw.



Z420



12 PC

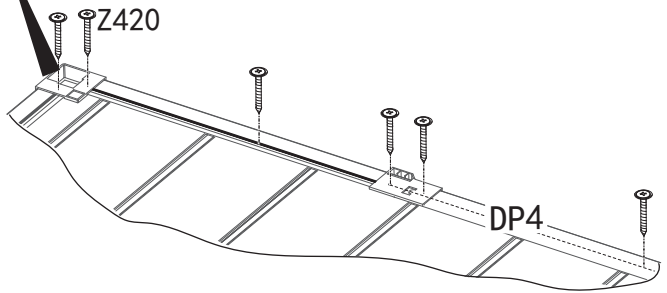

9-2

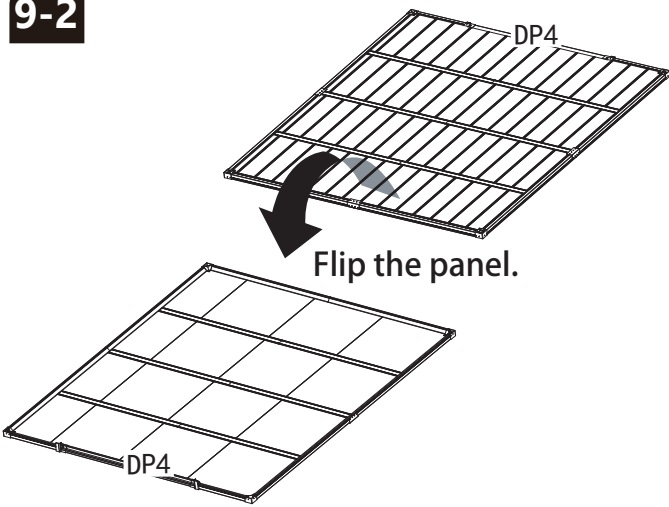

9-3

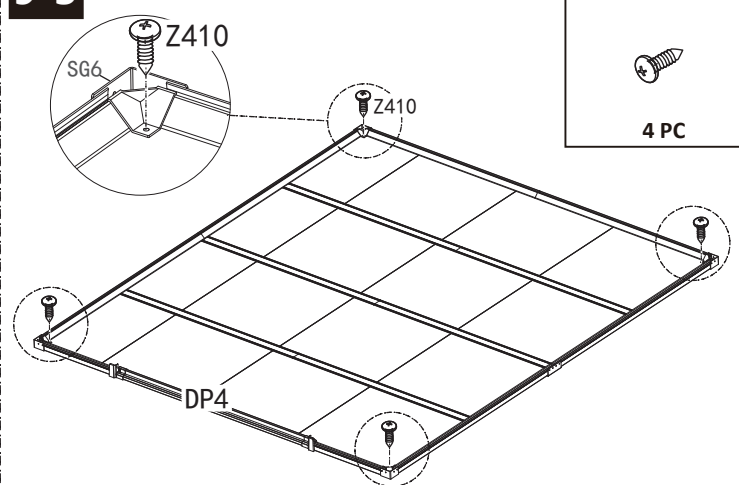

Z410



4 PC

WALL ASSEMBLY

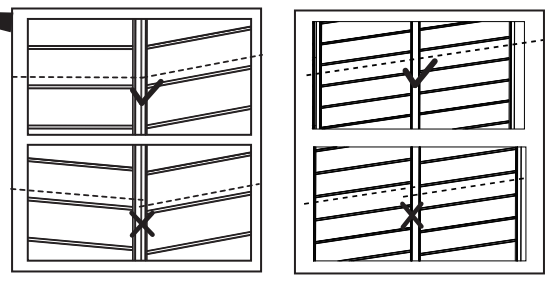
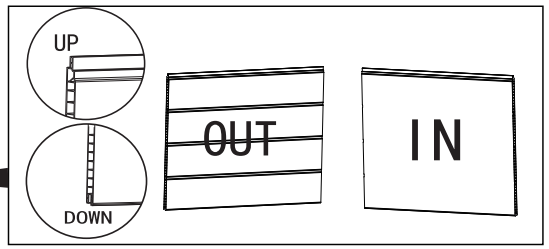
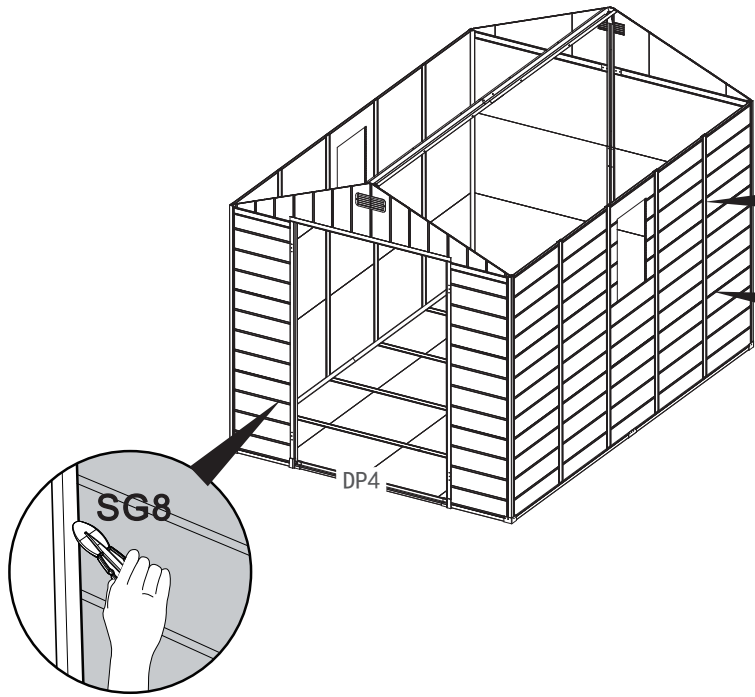

Step 10

DP5

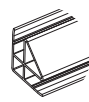

2 PC

PPA2

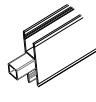

1 PC

PPA1

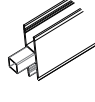

1 PC

QW2-2



2 PC

QW2-1



4 PC

QW1-1



6 PC

10-1

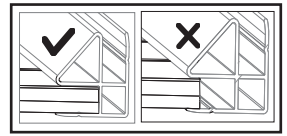
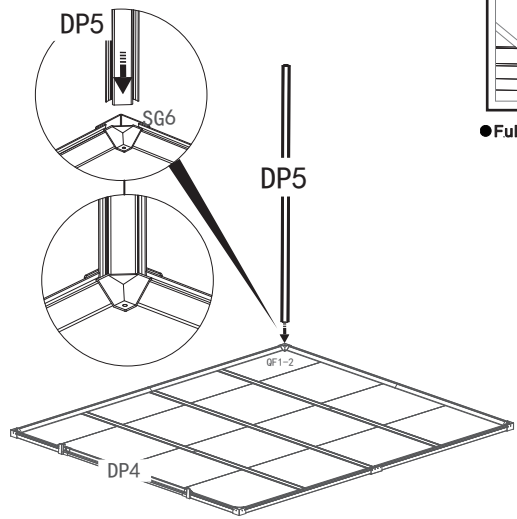

● Fully fit the panel inside the profile

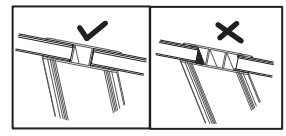

● Fully fit the panel inside the profile

SG8



10-2

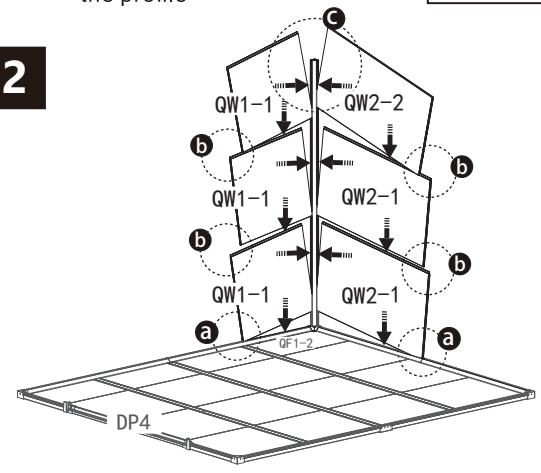

10-3

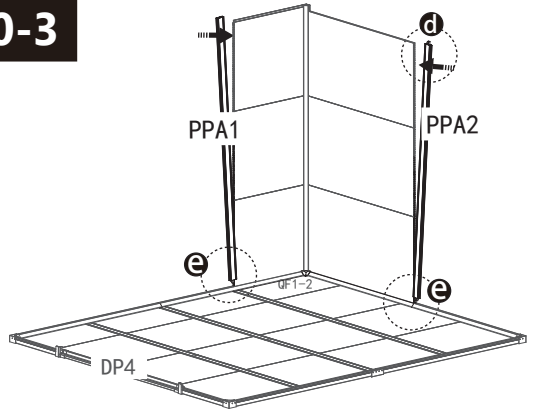

10-4

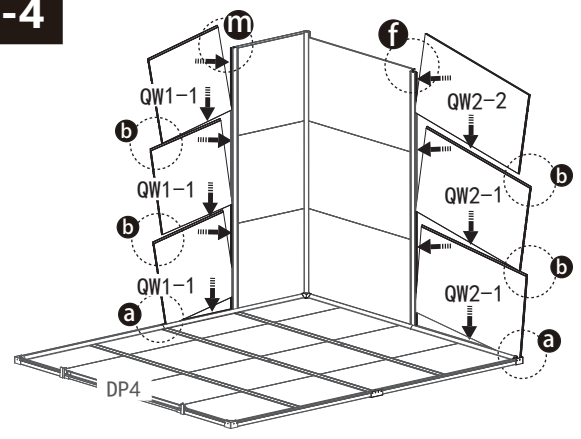

10-5

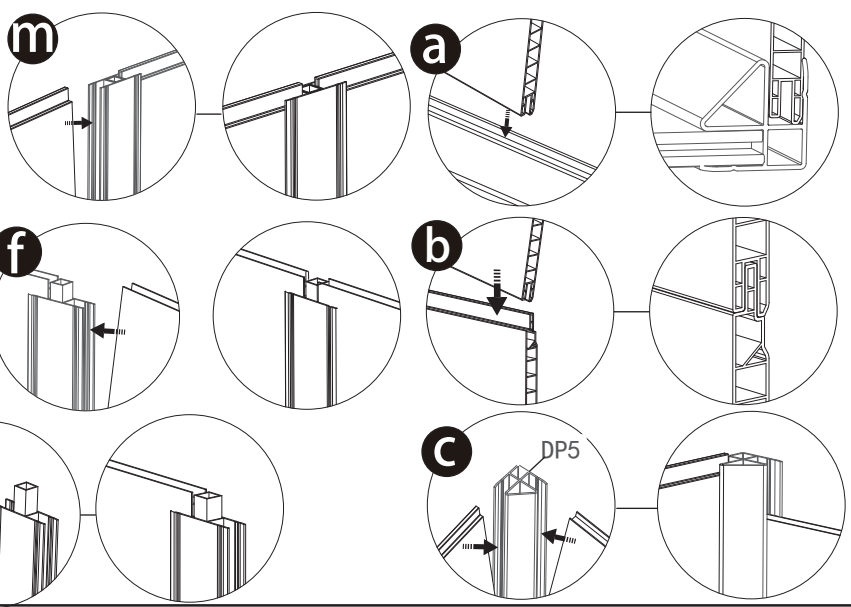
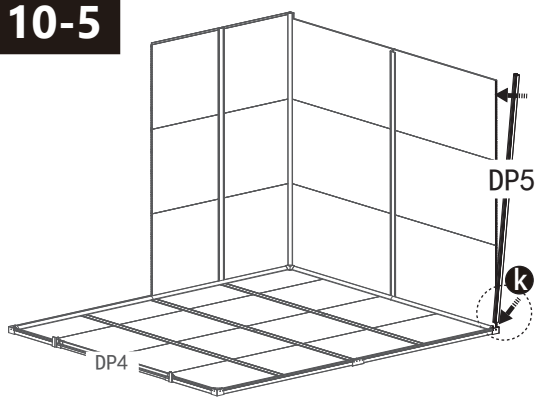



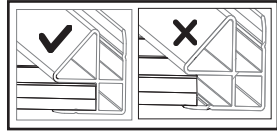

Step 11

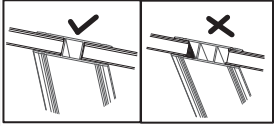

● Fully fit the panel inside the profile

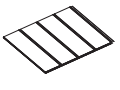

● Fully fit the panel inside the profile

PPA1  5 PC	QW1-2  2 PC	QW1-3  2 PC	QW1-1  8 PC
SG8 			

11-1

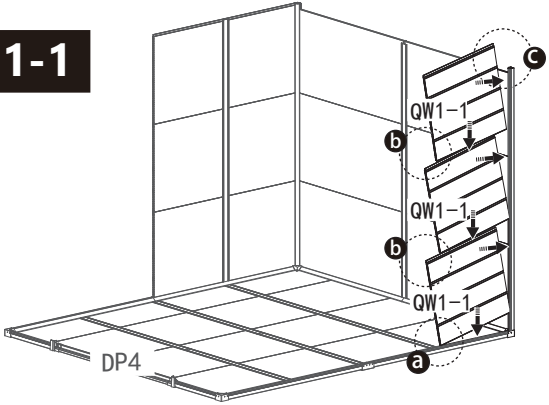

11-2

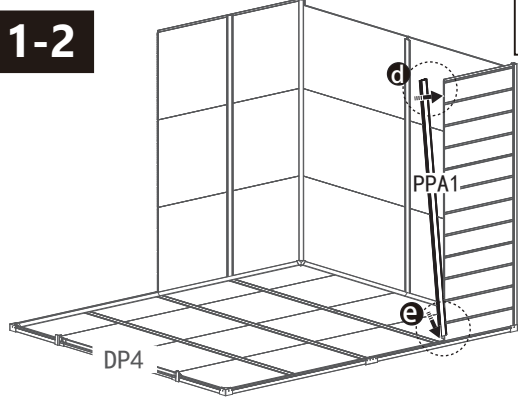

11-3

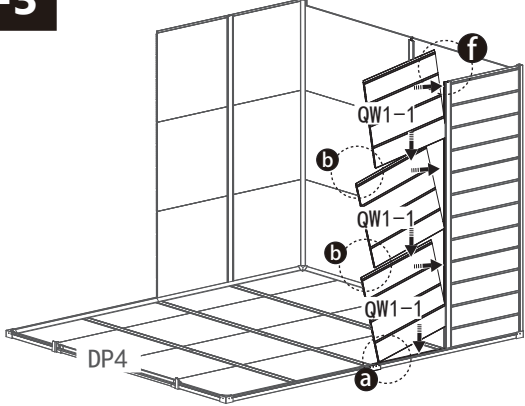

11-4

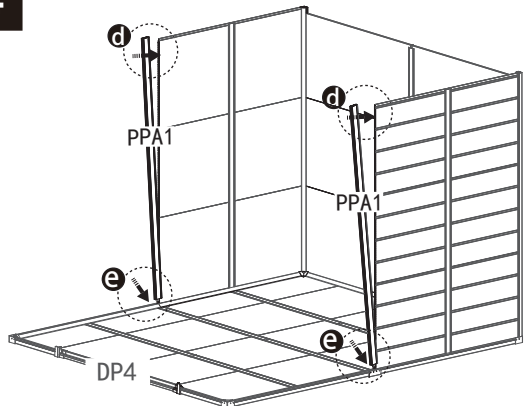

11-5

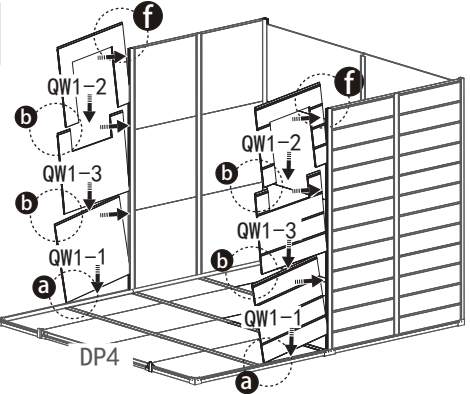

11-6

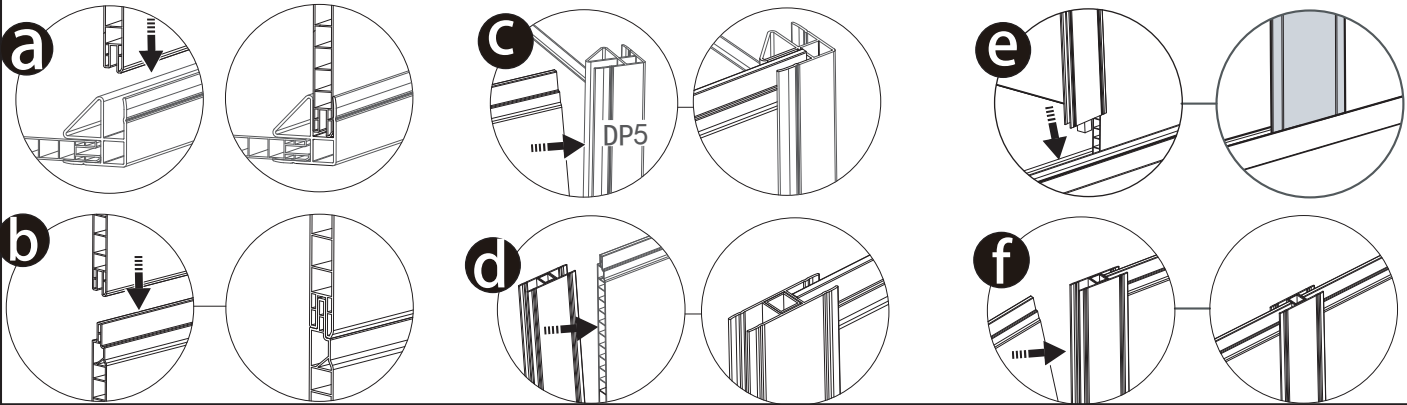
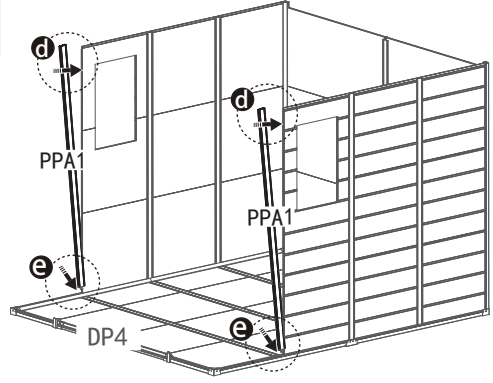

Step 12

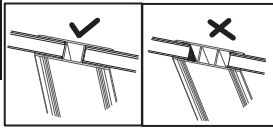

● Fully fit the panel inside the profile

SG8



QPA1



2 PC

DP5



2 PC

QW1-1

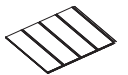

6 PC

12-1

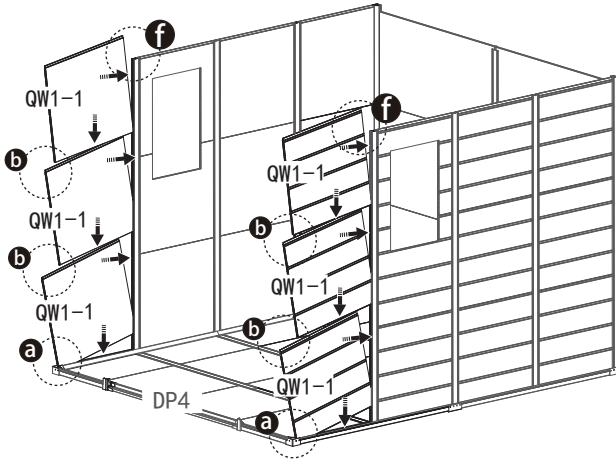

12-2

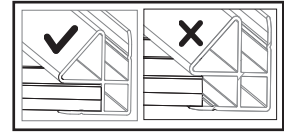

● Fully fit the panel inside the profile

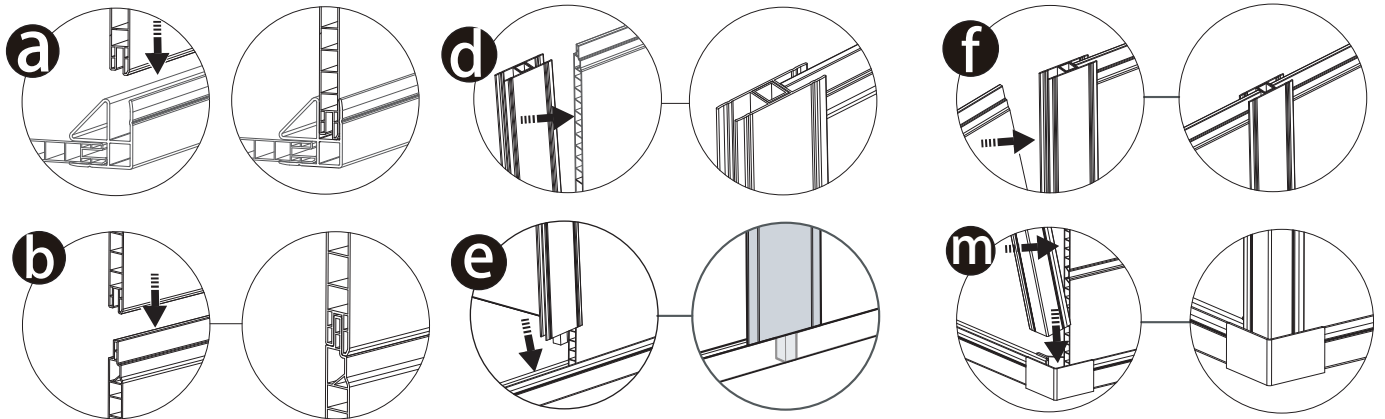
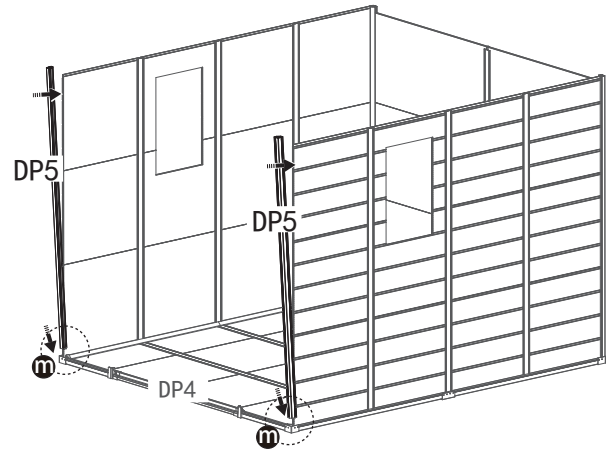

12-3

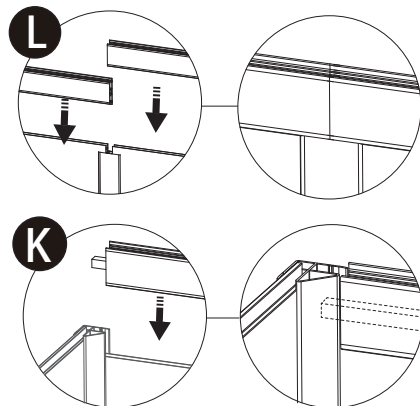
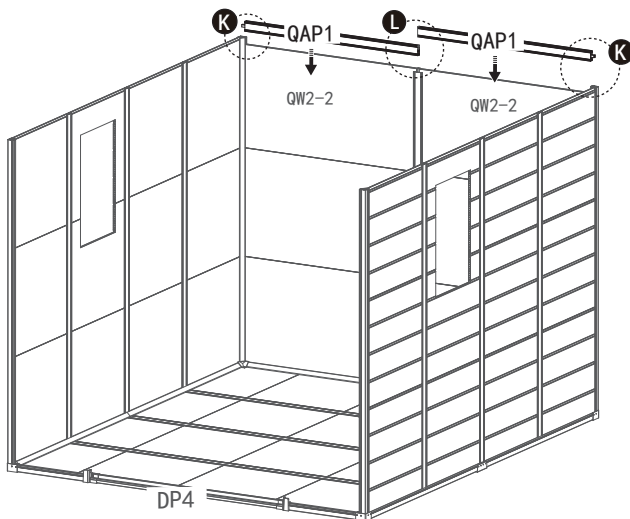

Step 13

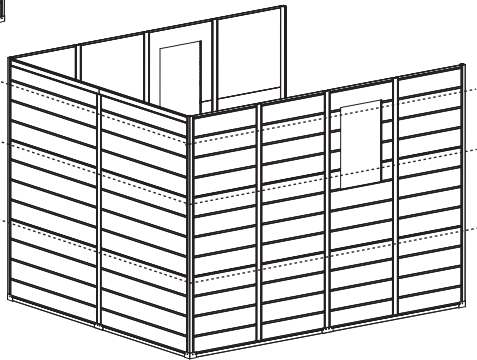
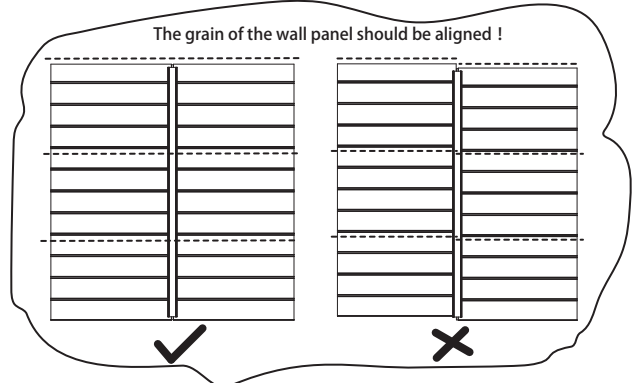
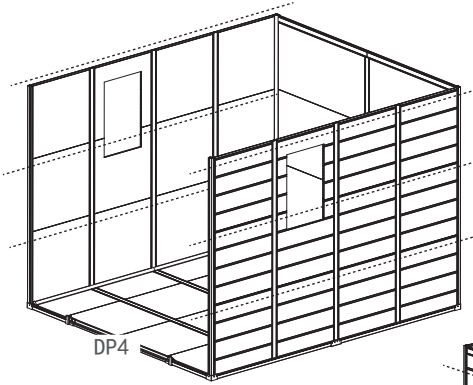

Step 14

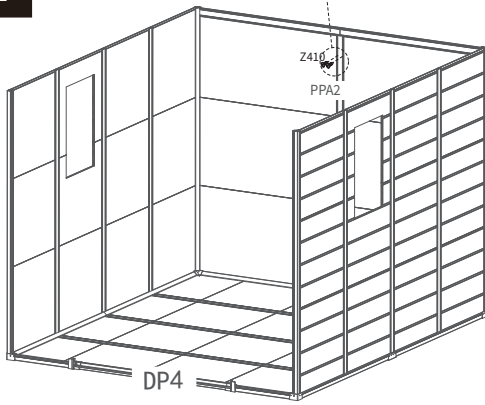
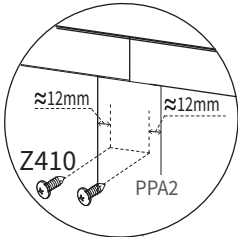

14-1

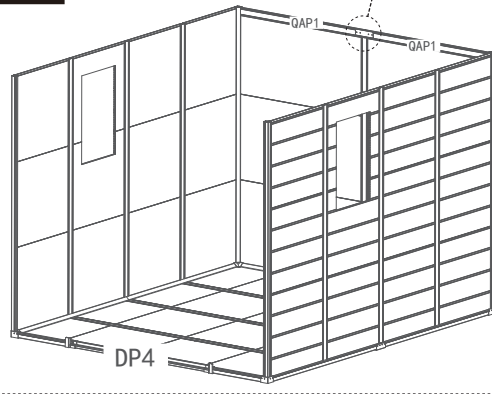
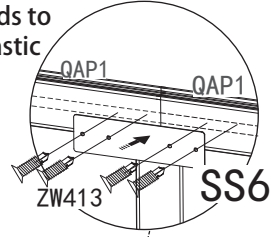

14-2

Attention to the location of the screws: they need to be locked on the iron pipe that corresponds to the inside of the plastic profile.

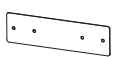

- SS6**

1 PC
- ZW413**

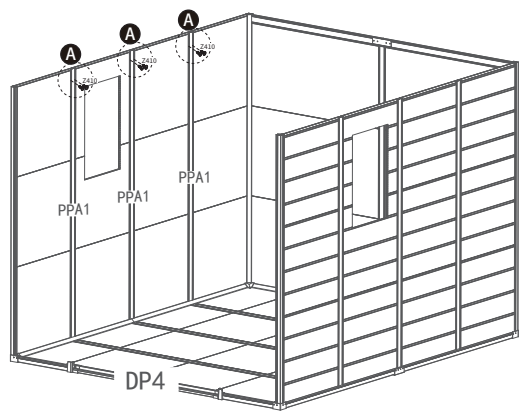
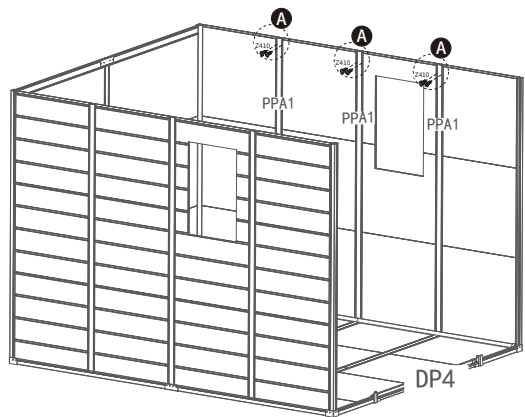
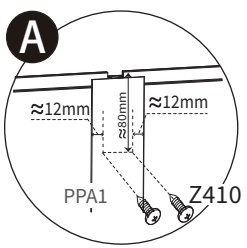
4 PC
- Z410**

14 PC

14-3

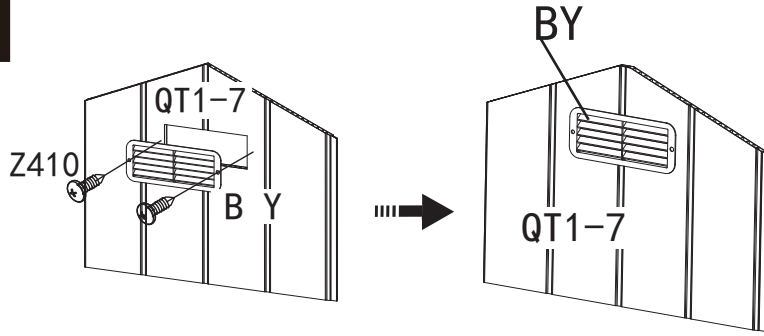

Step 15

15-1



QT1-8 1 PC	QT1-7 1 PC
QT1-10 1 PC	BY 1 PC
QT1-9 1 PC	Z410 2 PC
QT1-6 1 PC	

15-2

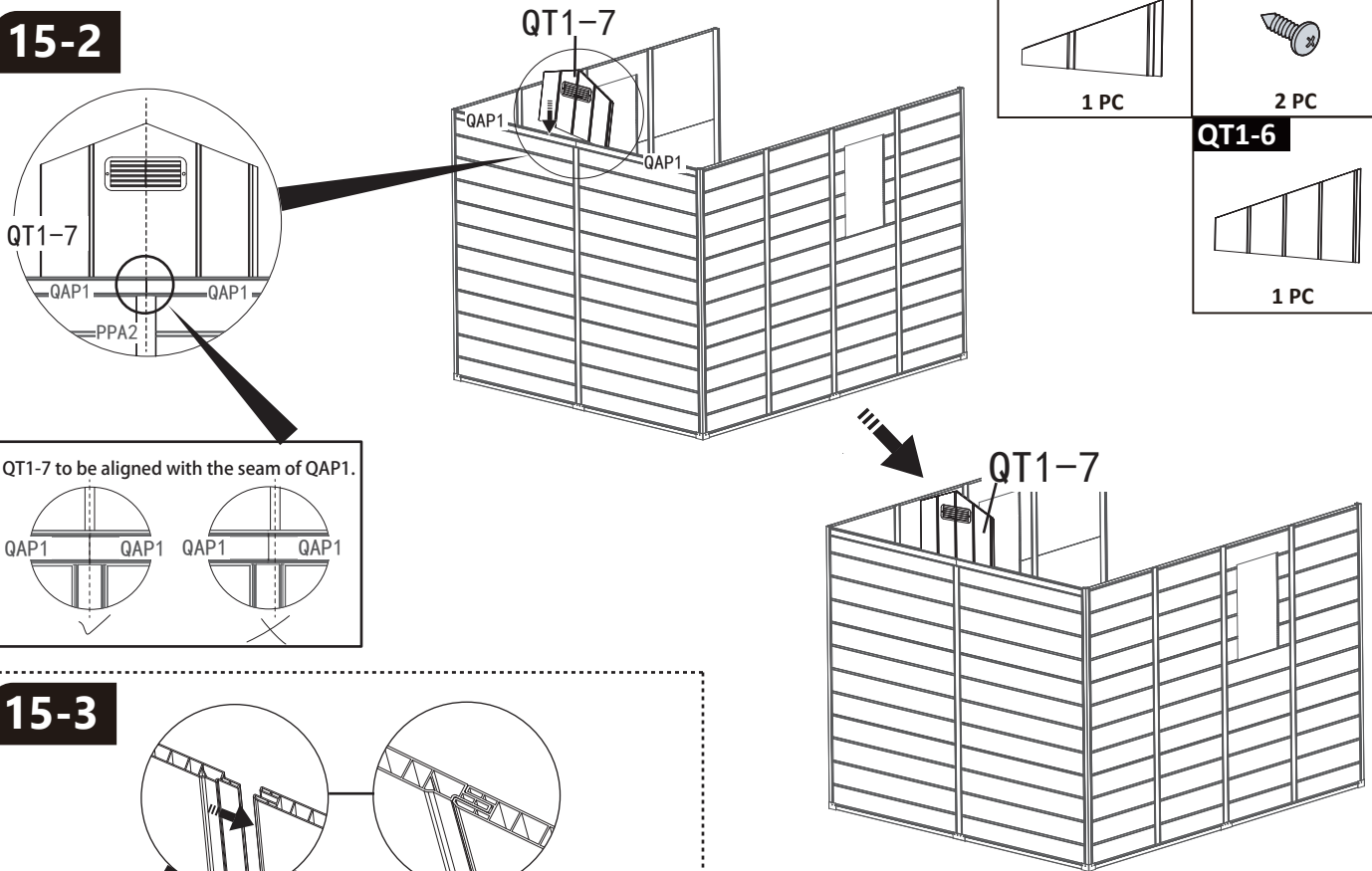

15-3

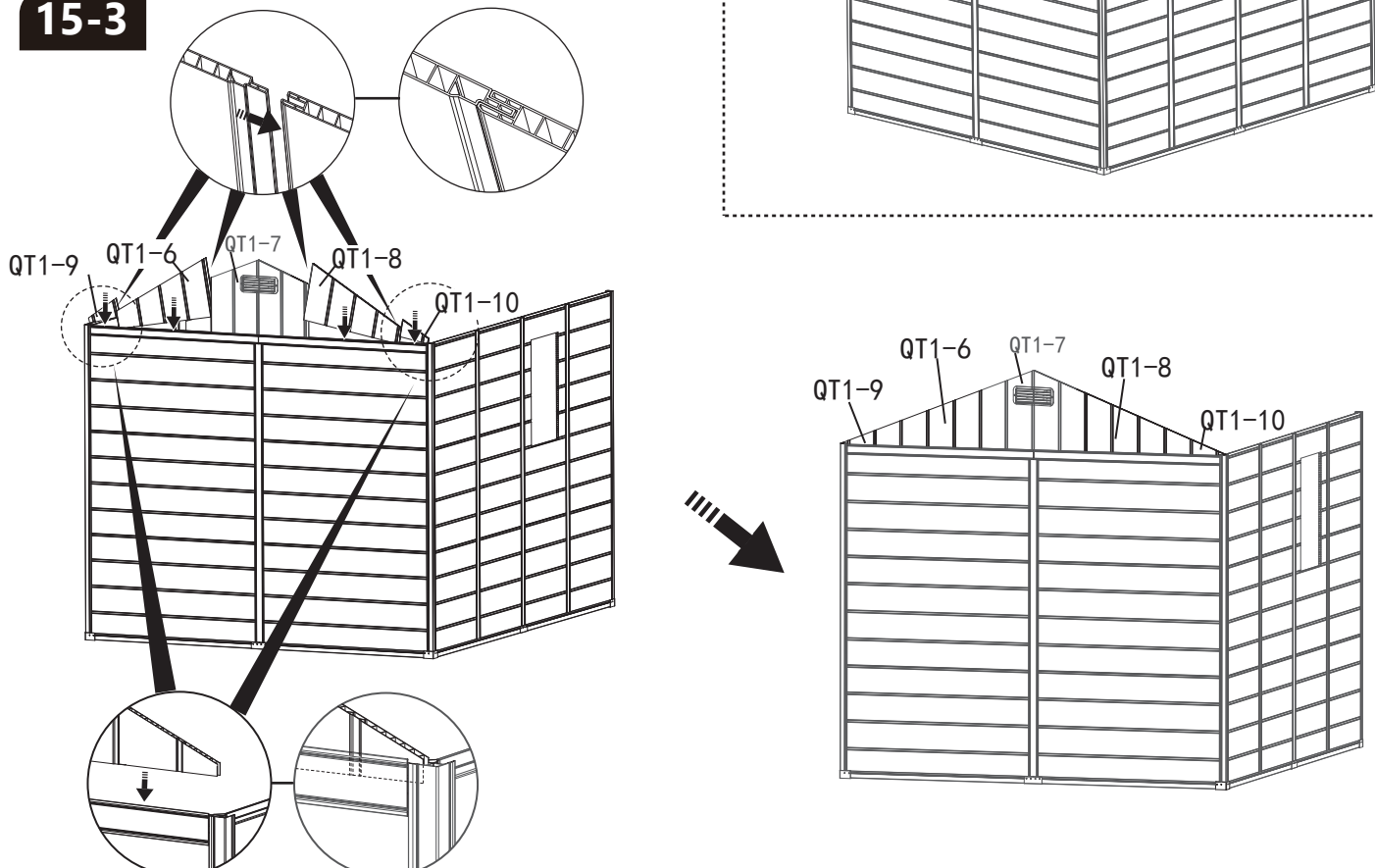

Step 16

16-1

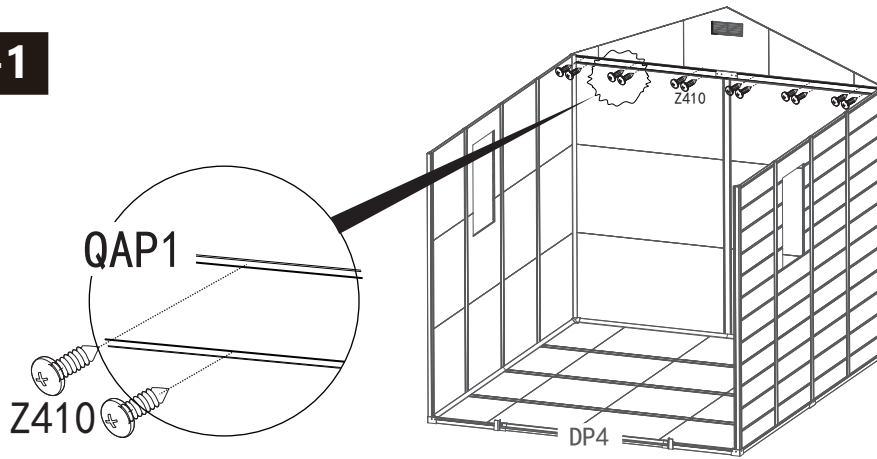

SG8



Z410



14 PC

QW3-2



2 PC

QW3-1



4 PC

DA1L

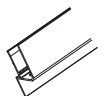

1 PC

DA1R



1 PC

QAP3



2 PC

16-2

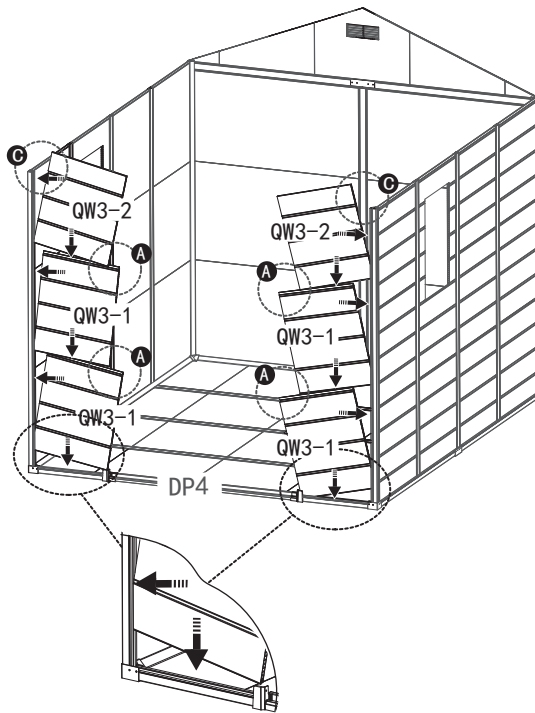

16-3

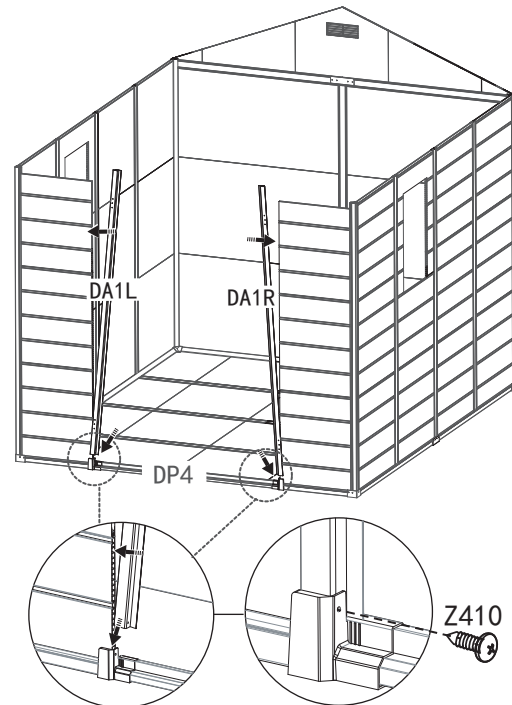

16-4

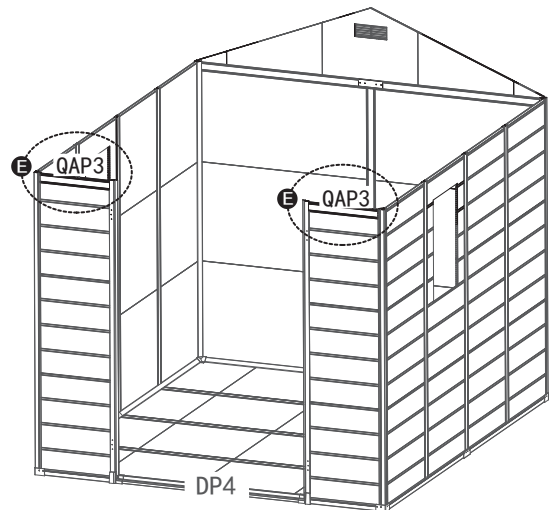
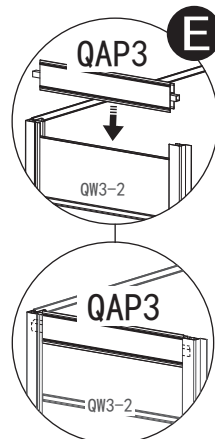
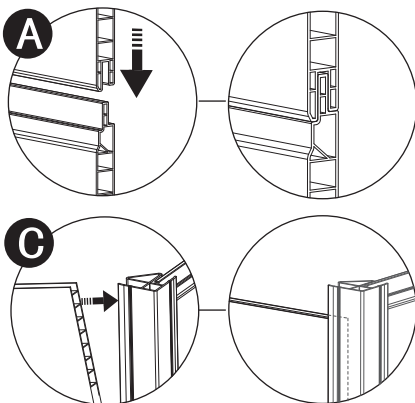

Step 17

17-1

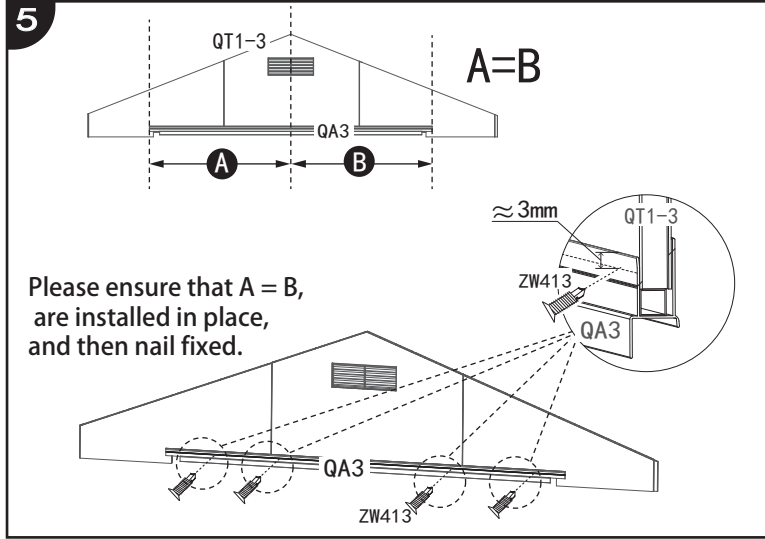
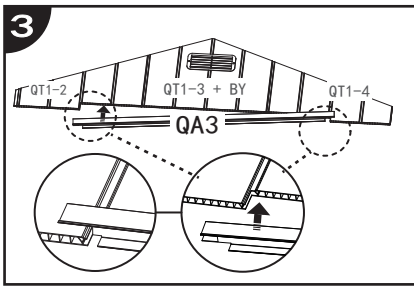
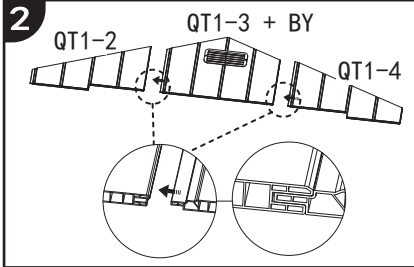
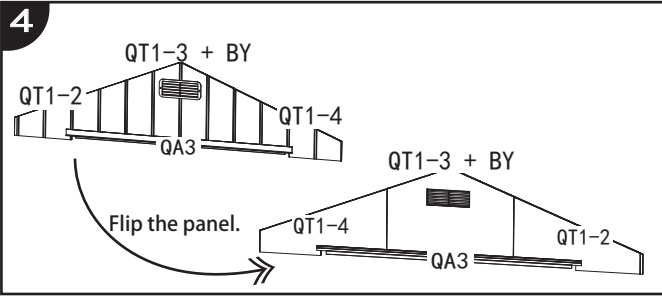
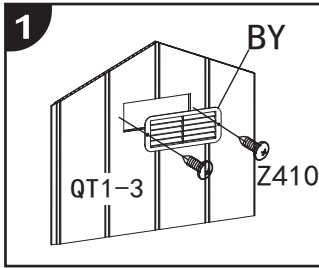

17-2

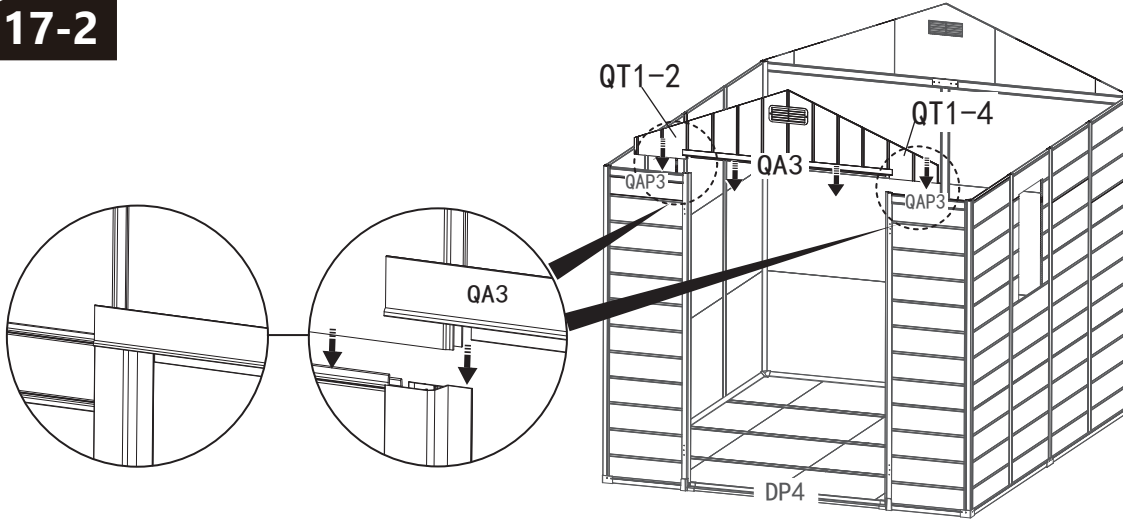

17-3

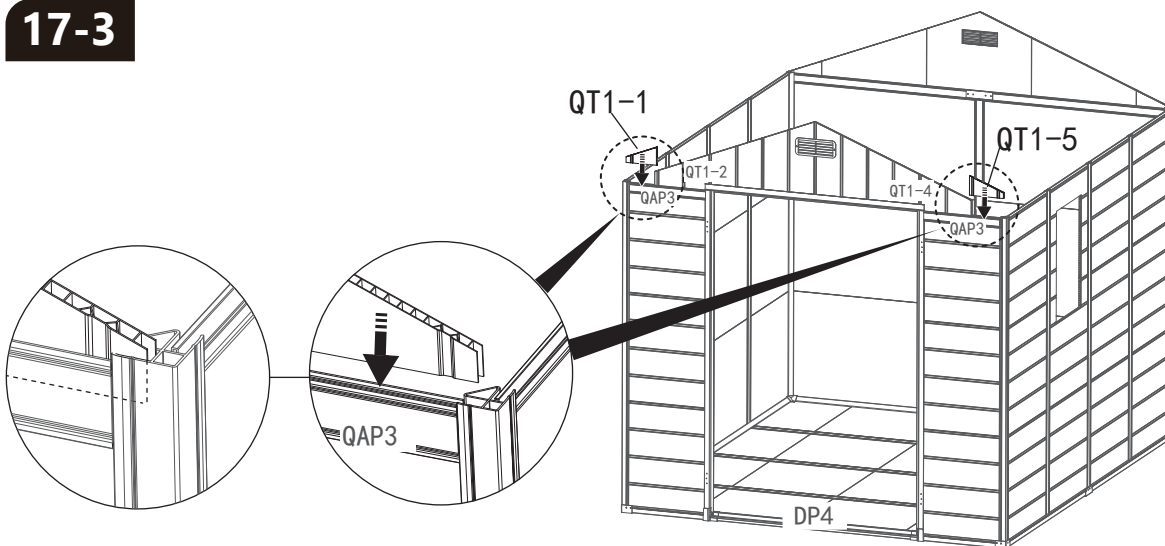

QT1-3

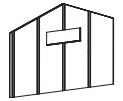

1 PC

Z410



2 PC

BY



1 PC

QT1-2

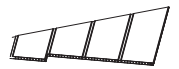

1 PC

QT1-4

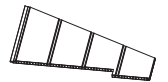

1 PC

QA3

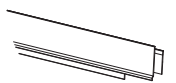

1 PC

QT1-1



1 PC

QT1-5

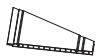

1 PC

ZW413



4 PC

Step 18

18-1

Caution:
Please use Drill  to predrill
a hole at depth 1mm before screw.

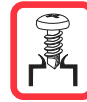

Z420



10 PC

ZW413



8 PC

SG27



2 PC

AB=CD

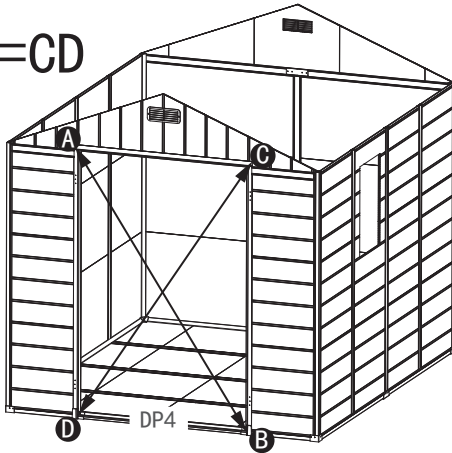

Please keep both
sides QAP3 on a line

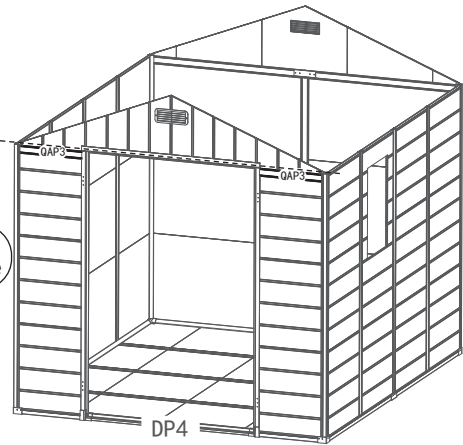

18-2

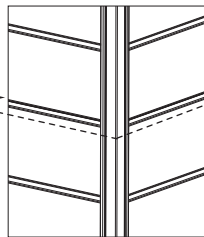
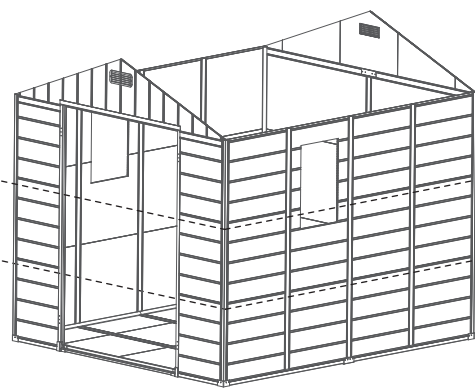

Make sure the plate
lines are consistent.

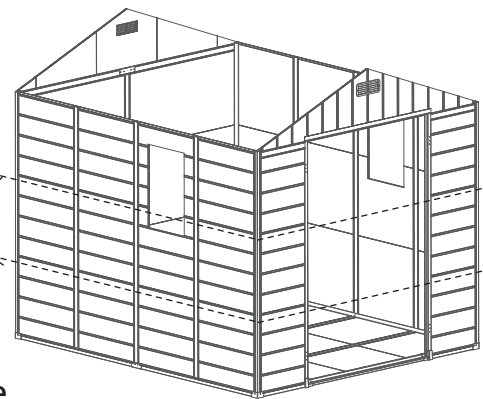

18-2

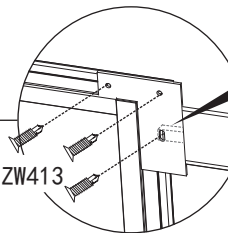
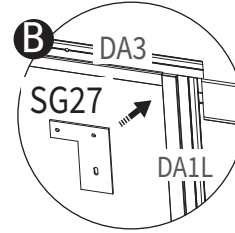
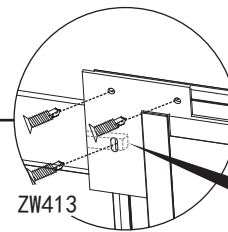
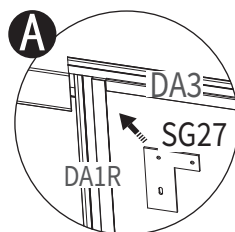
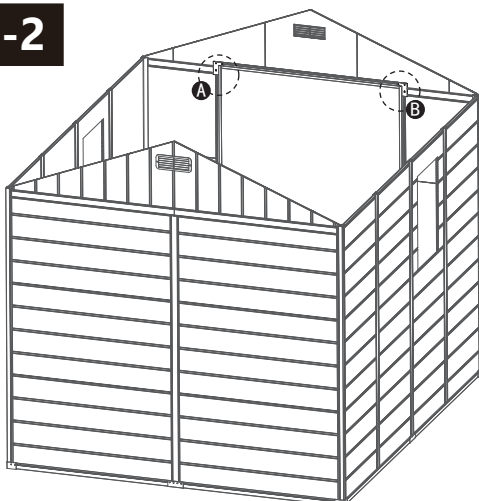

Attention to the location
of the screws: they need
to be locked on the iron
pipe that corresponds
to the inside of the
plastic profile.

Step 19

19-1

Caution:
Please use Drill  to predrill
a hole at depth 1mm before screw.

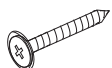

ZW413	Z420
	
4 PC	56 PC

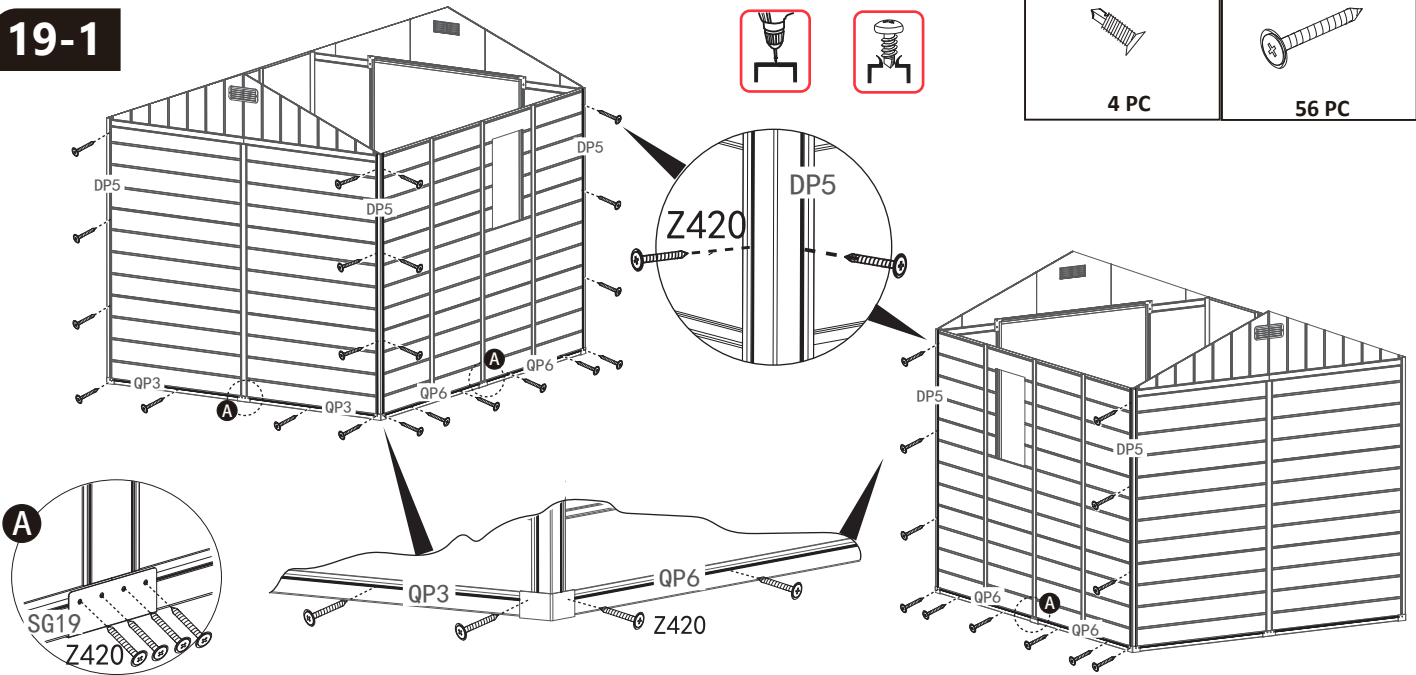

19-2

Attention to the location of the screws: they need to be locked on the iron pipe that corresponds to the inside of the plastic profile.

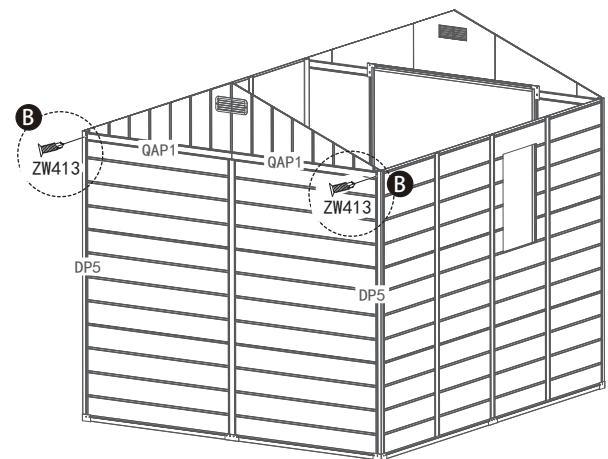
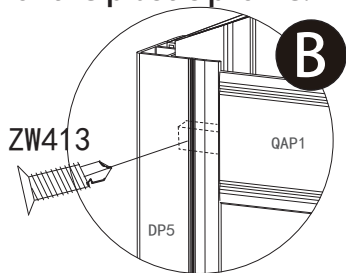

19-3

Attention to the location of the screws: they need to be locked on the iron pipe that corresponds to the inside of the plastic profile.

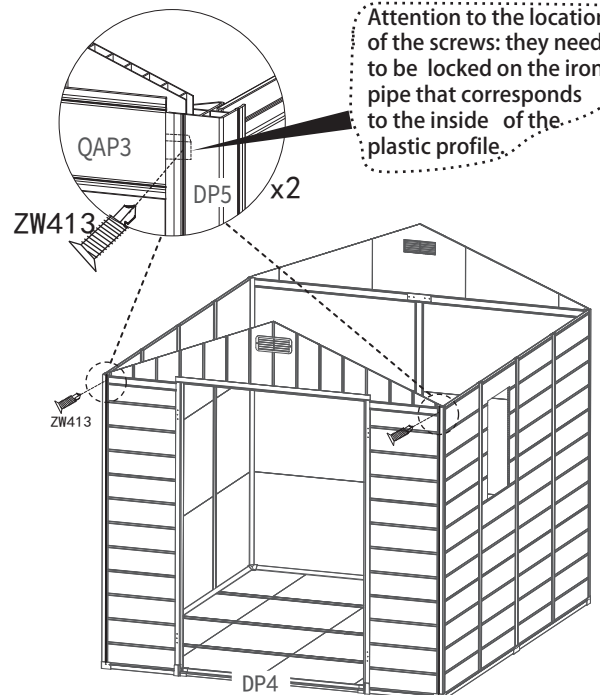
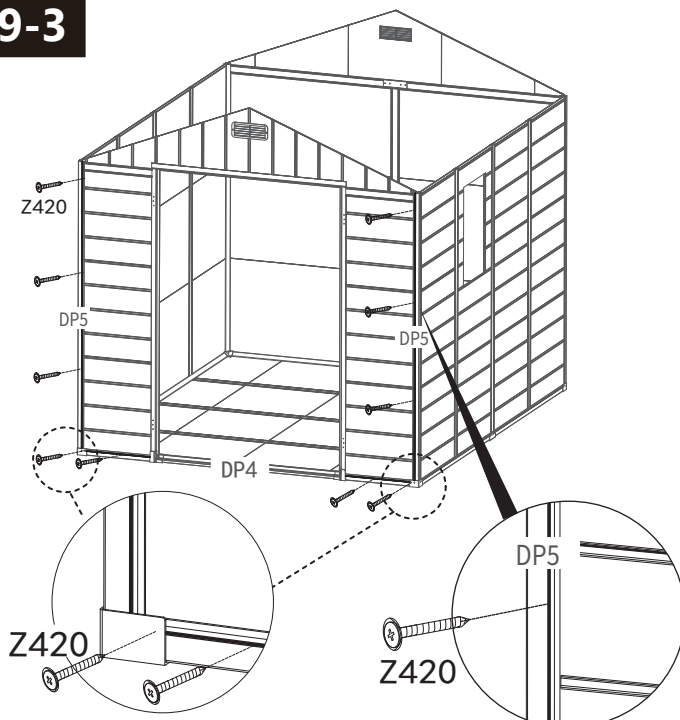

Step 20

20-1

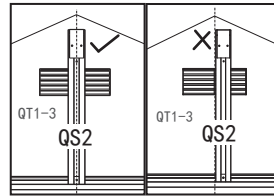
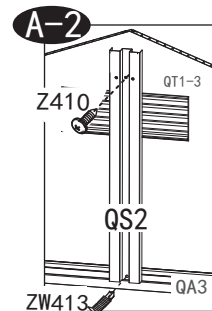
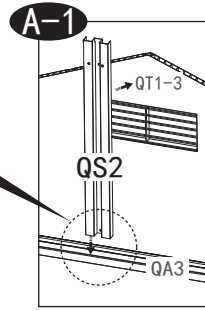
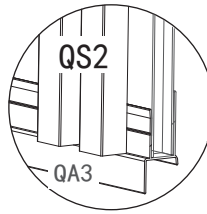
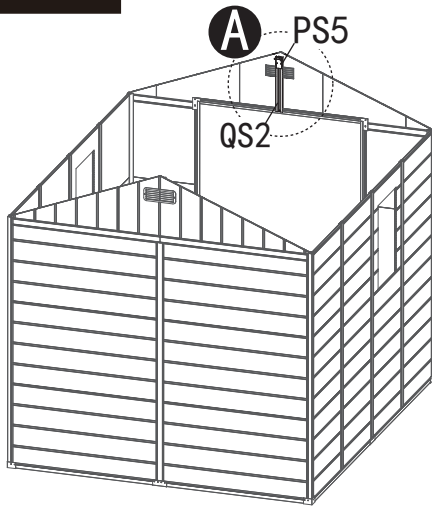

Pay attention to the placement of QS2

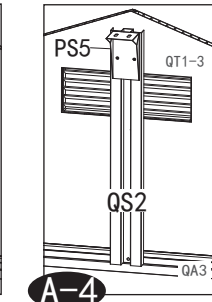
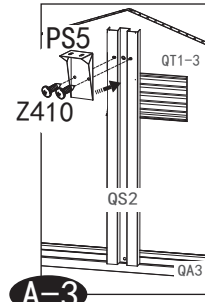

- Z410**

7 PC
- ZW413**

8 PC
- PS5**

2 PC
- QS2**

1 PC
- SS4**

1 PC
- SS3**

1 PC

20-2

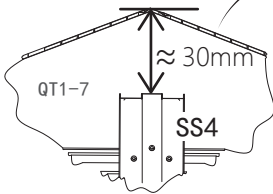

Pay attention to the placement of SS4

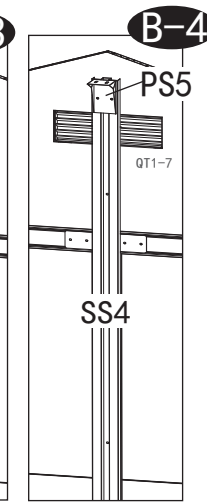
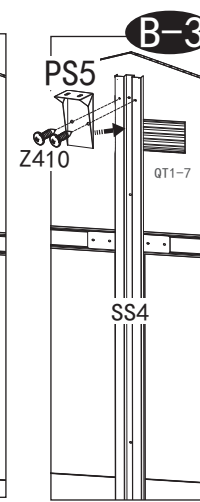
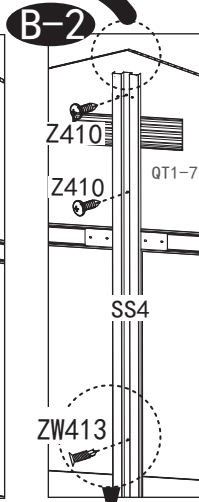
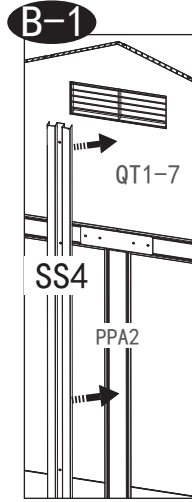
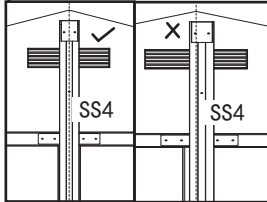

Attention to the location of the screws: they need to be locked on the iron pipe that corresponds to the inside of the plastic profile.

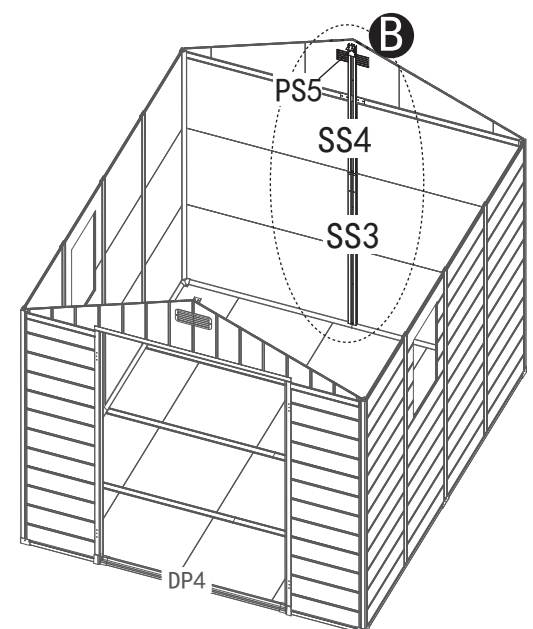
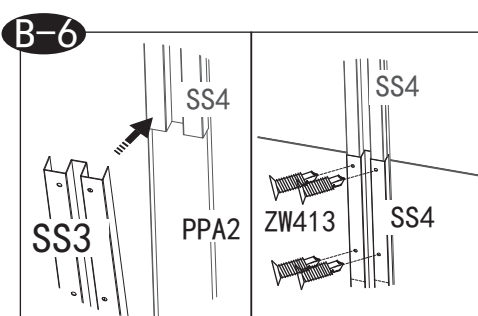
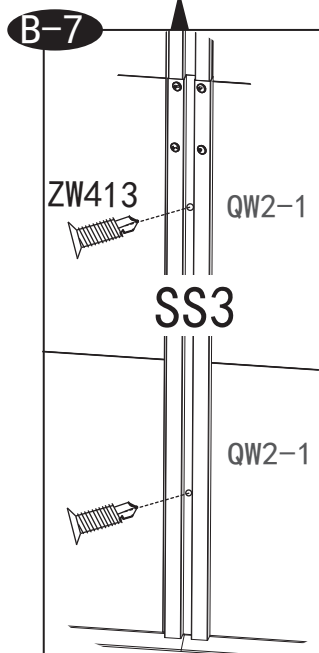
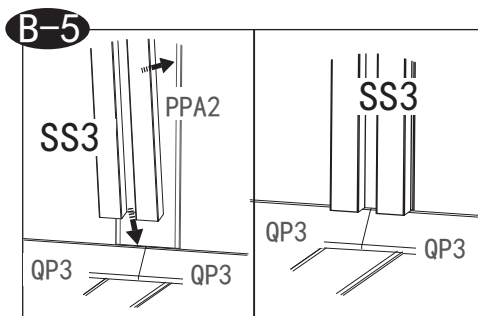

Step 21

21-1

1

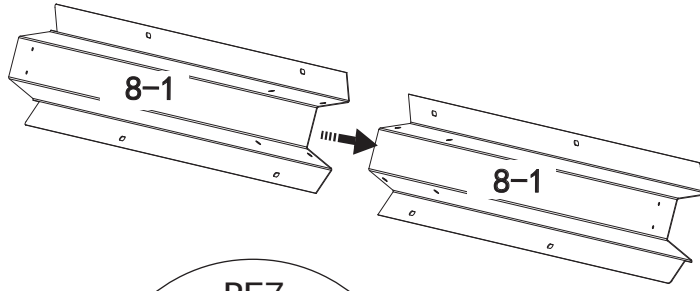

2

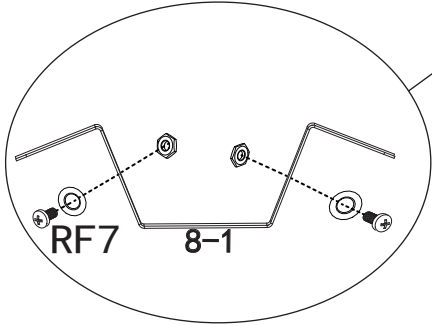
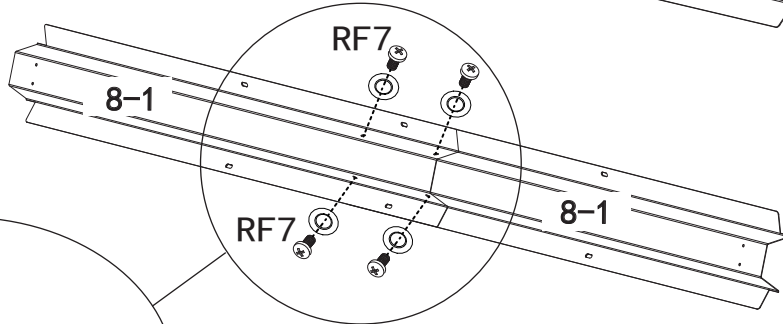

8-1



2 PC

RF7

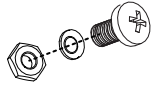

4 PC

Z410



4 PC

21-2

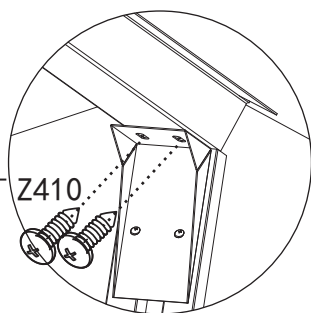
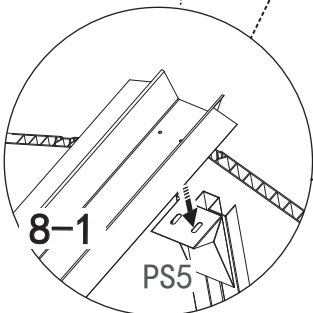
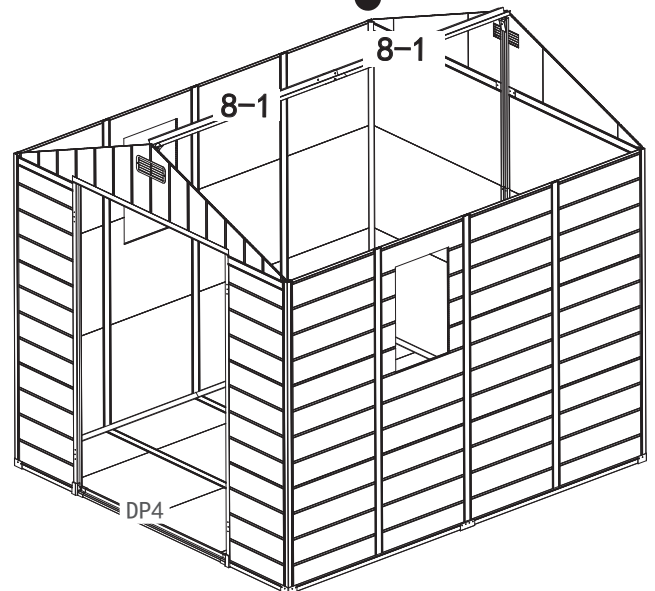
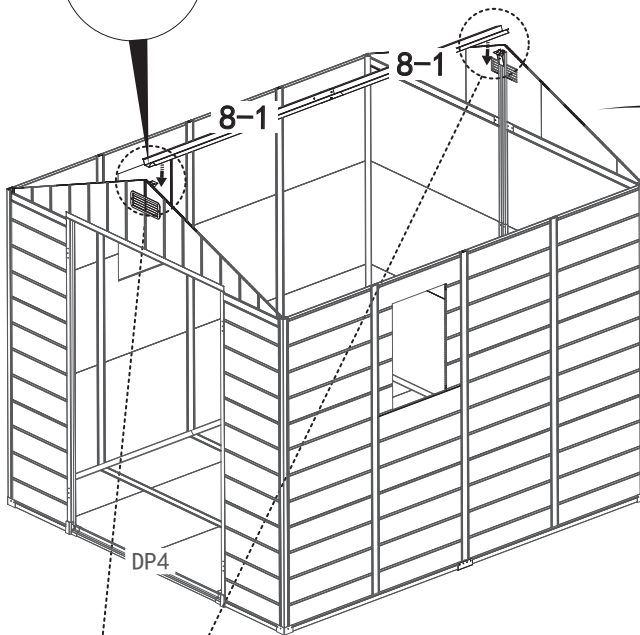
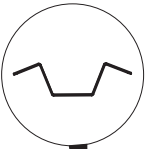

ROOF PARTS

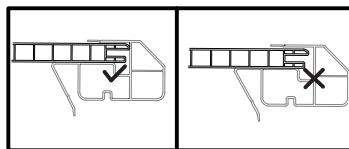

Fully fit the panel inside the profile



SG8

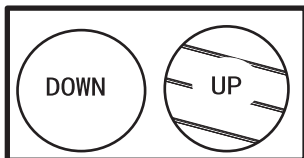
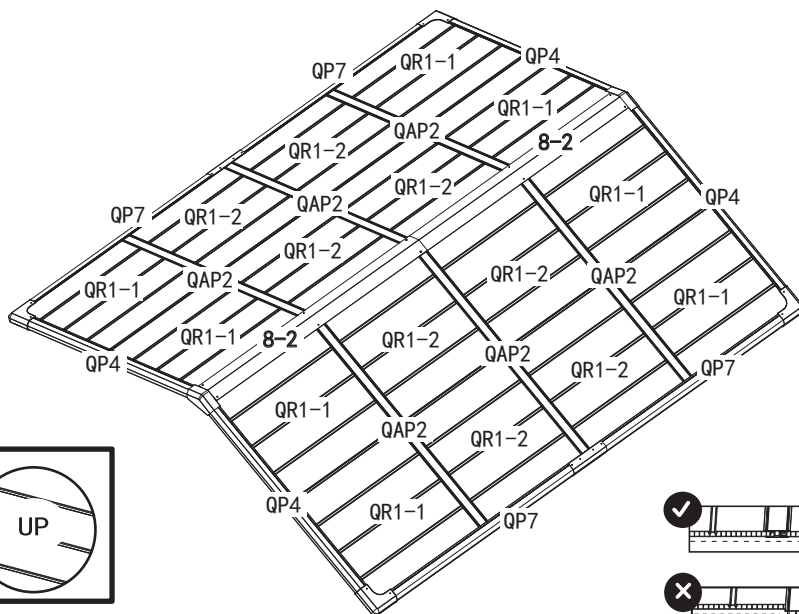

The stripes should be upwards

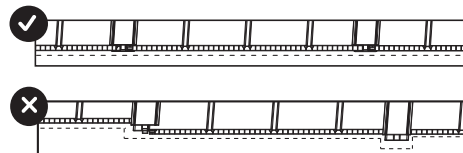

Step 22

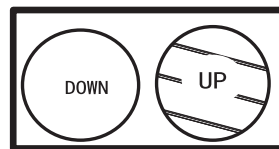
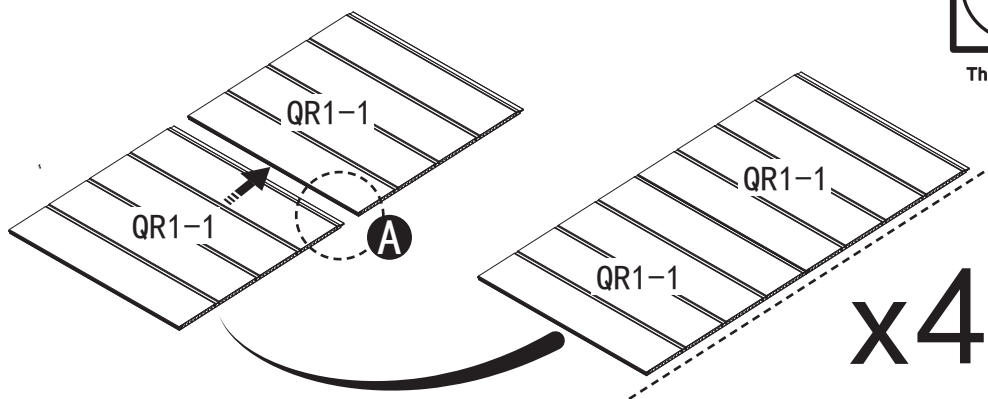

The stripes should be upwards

QR1-1



8 PC

QR1-2



8 PC

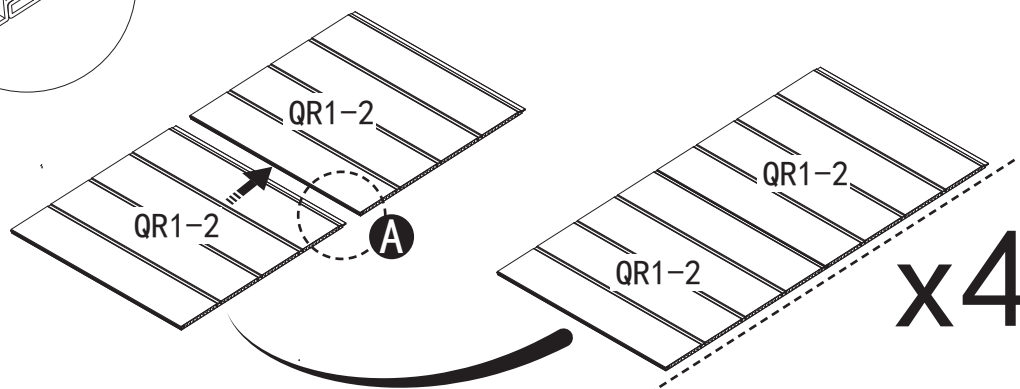
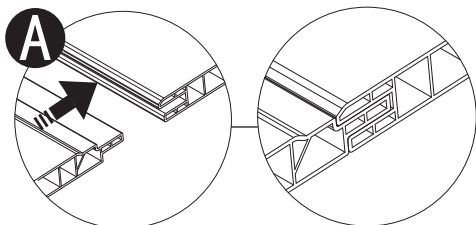

Step 23

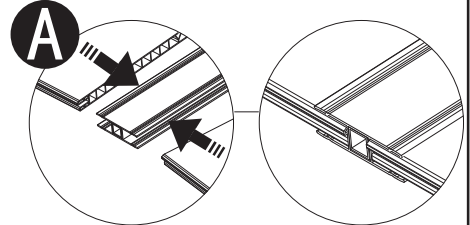
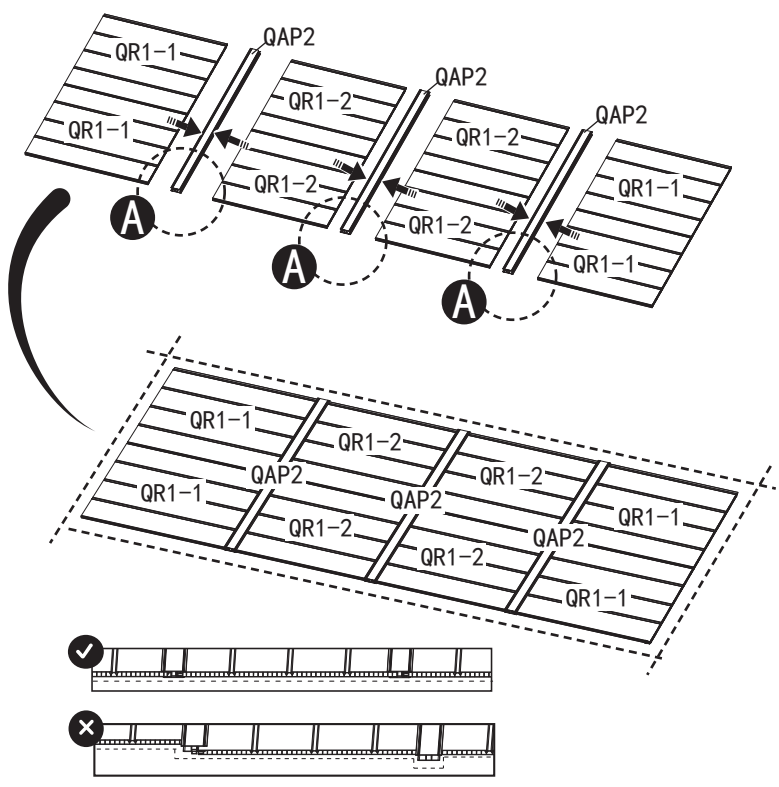
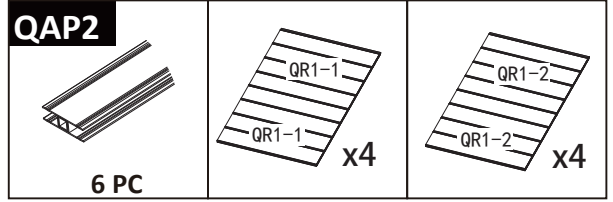

x2

Step 24

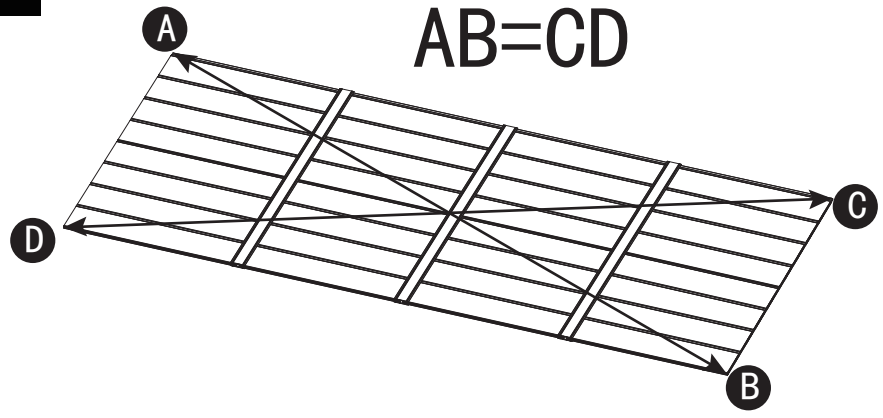
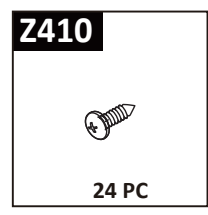



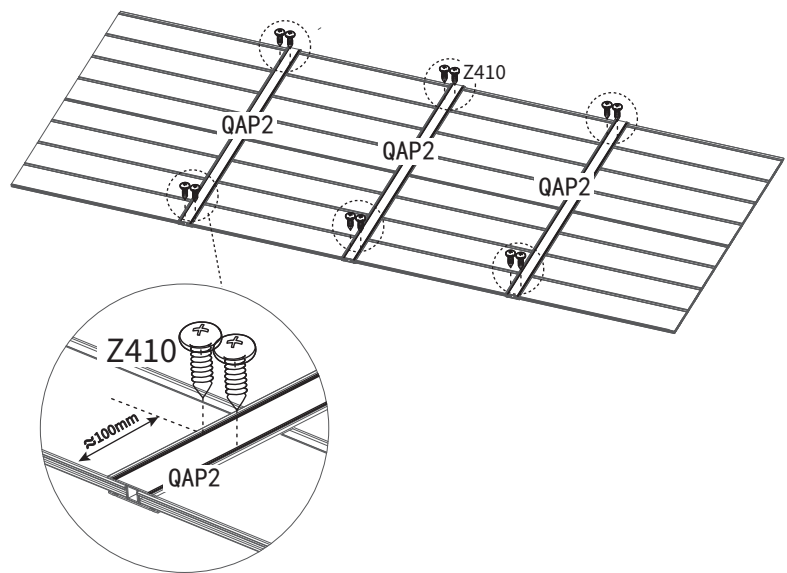



Make sure the sheet and profiles are in place before nailing



x2

Step 25

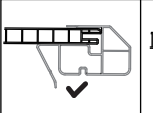
QP7  4 PC	Z410  8 PC
QP4  4 PC	SG20  2 PC
SG2  4 PC	SG8  4 PC
Z420  8 PC	 Fully fit the panel inside the profile

25-1

Flip the panel.

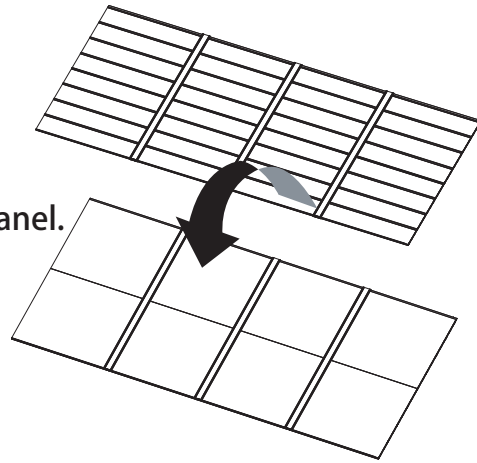

x2

25-2

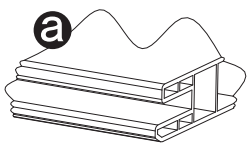
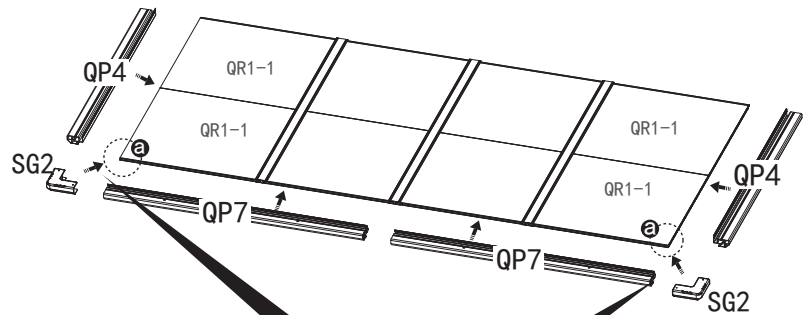

Please note the installation location

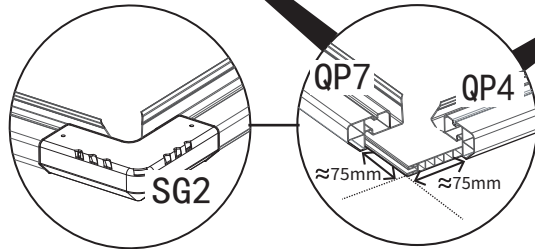

x2

25-3

A=B
C=D

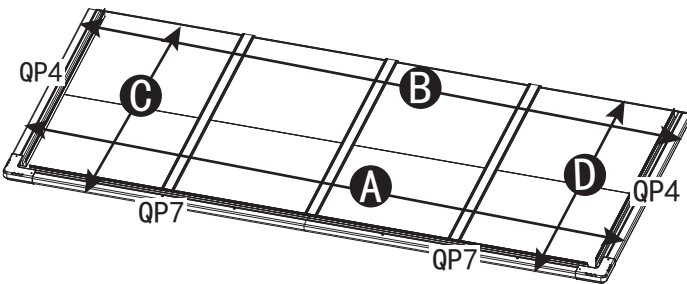

x2

25-4

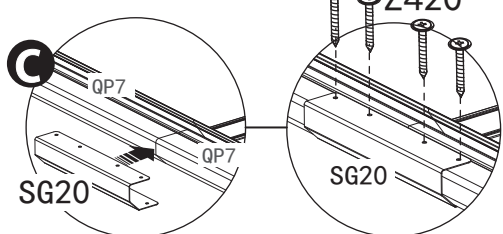
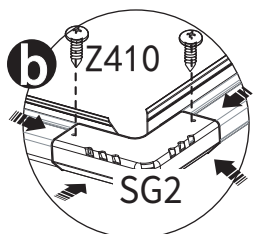
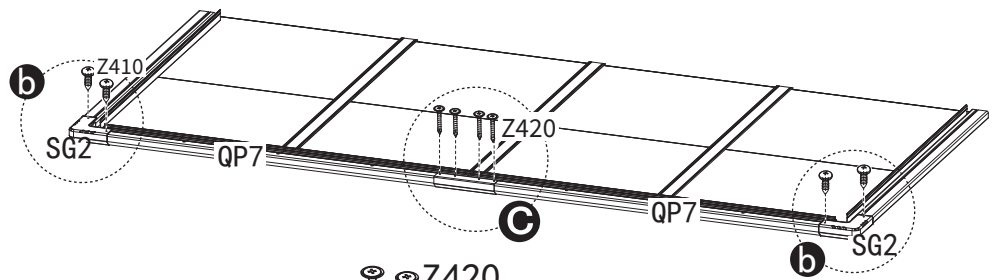

x2

Step 26

26-1

Flip the panel.

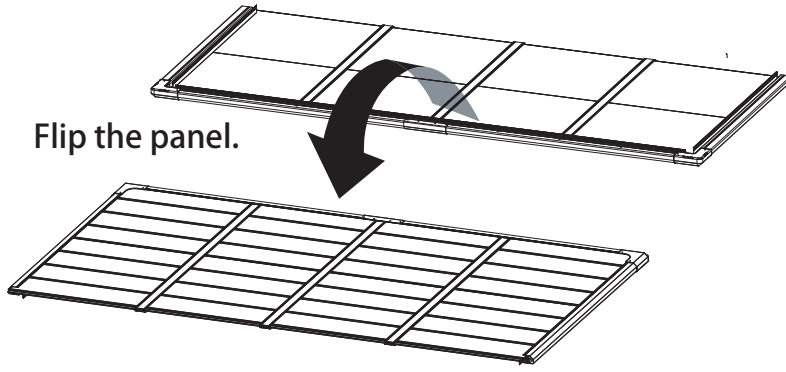

Z420



32 PC

x2

26-2

Caution:
Please use Drill to predrill
a hole at depth 1mm before screw.

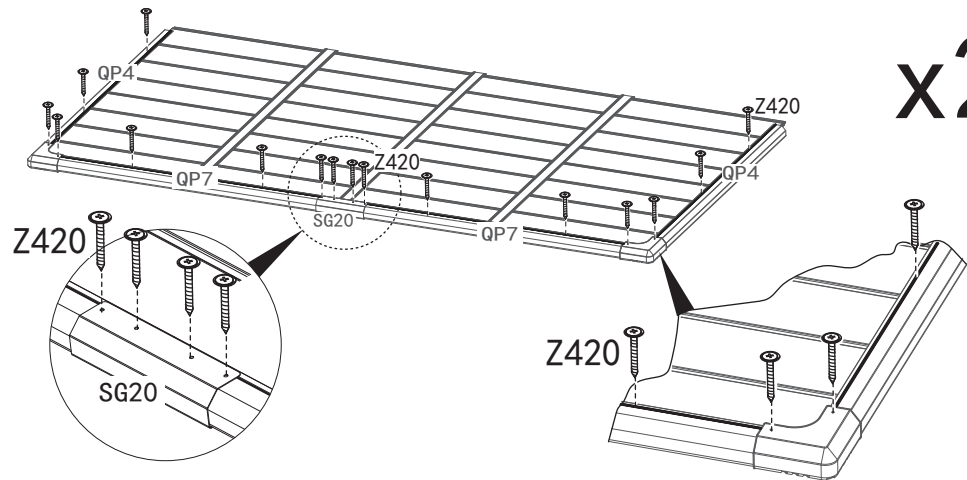
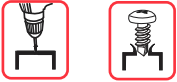

x2

26-3

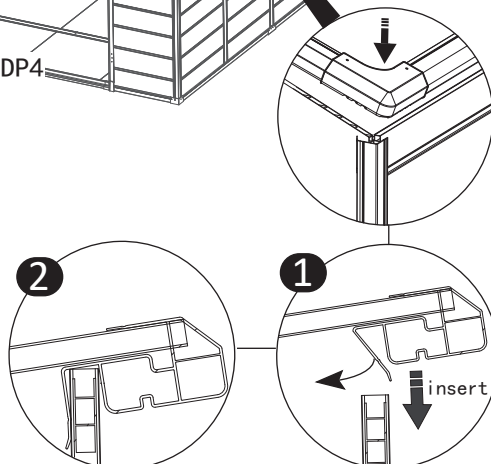
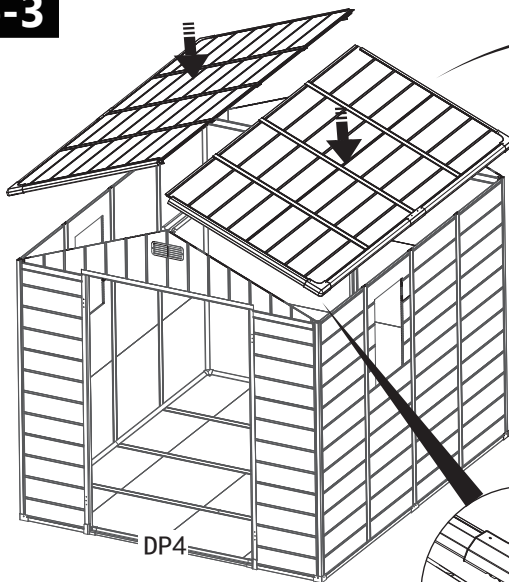

Fully fit the panel inside the profile

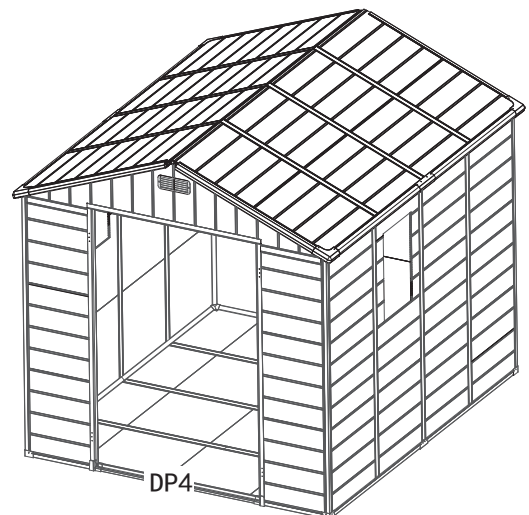

Step 27

Fully fit the panels inside the profiles of roof

SG8



27-1

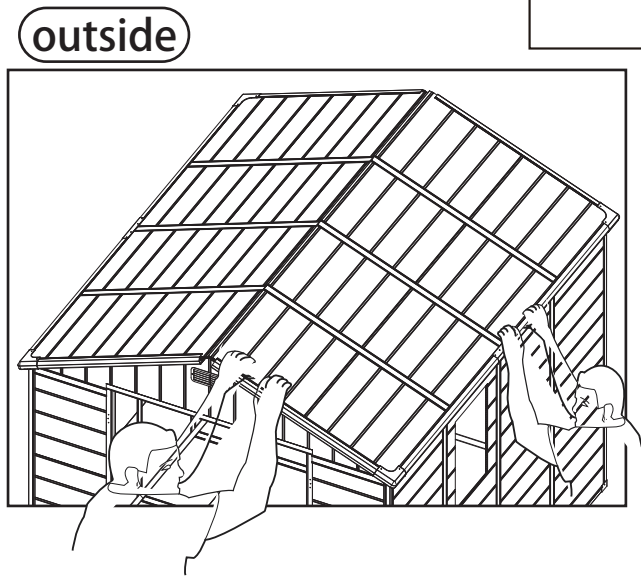
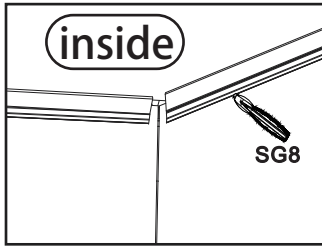
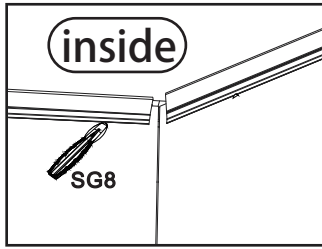

27-2

QAP2 and PPA1 should be aligned once the roof is installed.

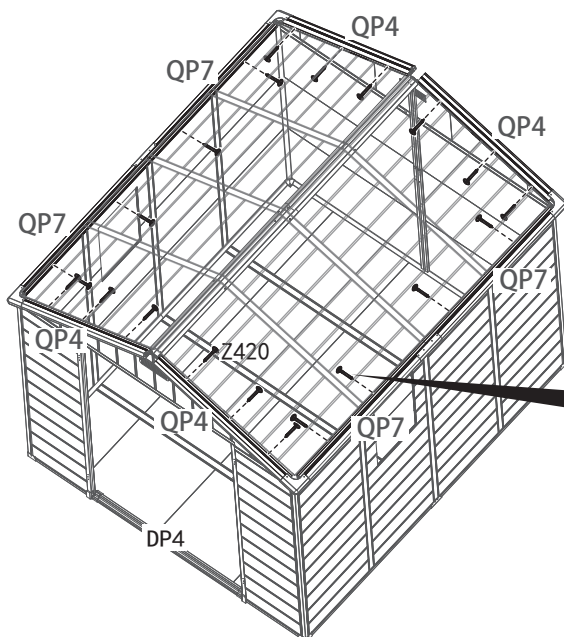
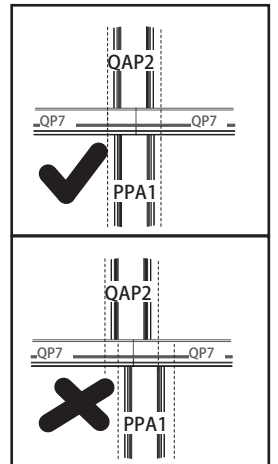
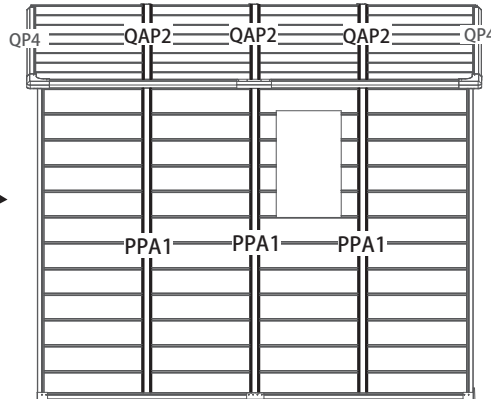
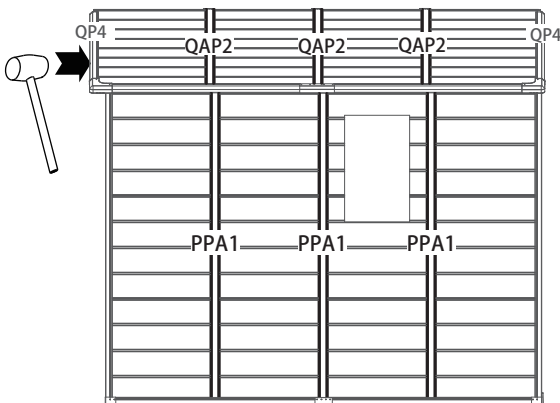

Caution:
Please use Drill to predrill a hole at depth 1mm before screw.

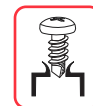
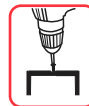

Z420



20 PC

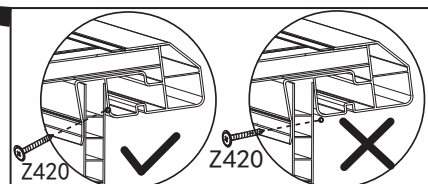

Step 28

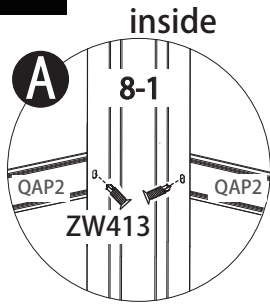

Attention to the location of the screws: they need to be locked on the iron pipe that corresponds to the inside of the plastic profile.

Attention : for the convenience of screwing, please press the board when you screw.

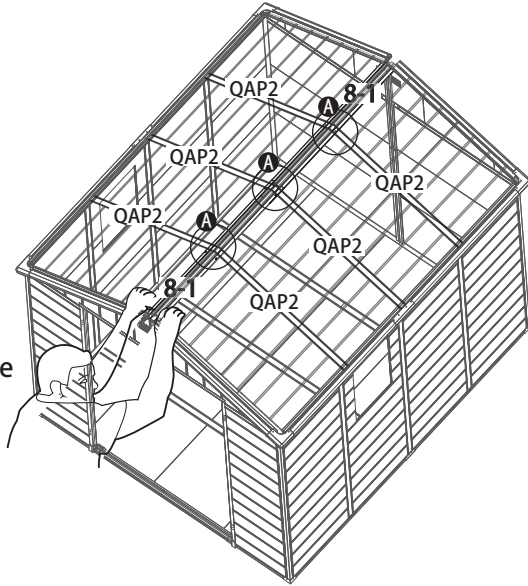

ZW413



6 PC

Step 29

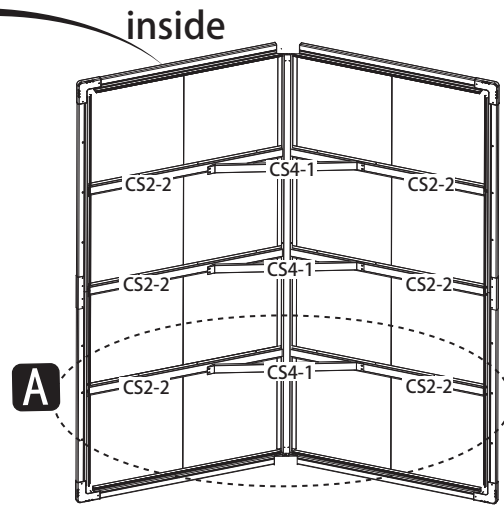
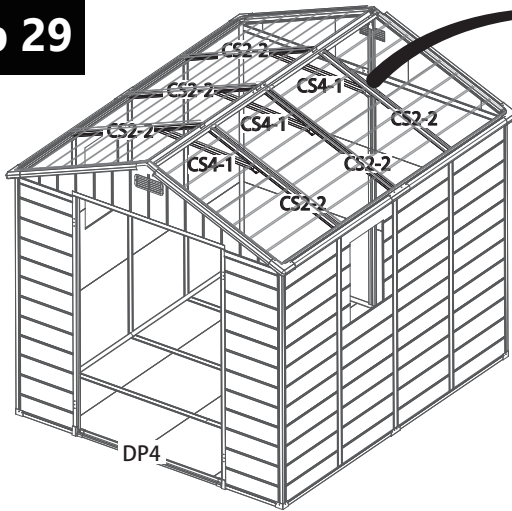

CS4-1



3 PC

Z420



12 PC

ZW413



24 PC

CS2-2



6 PC

Z410



24 PC

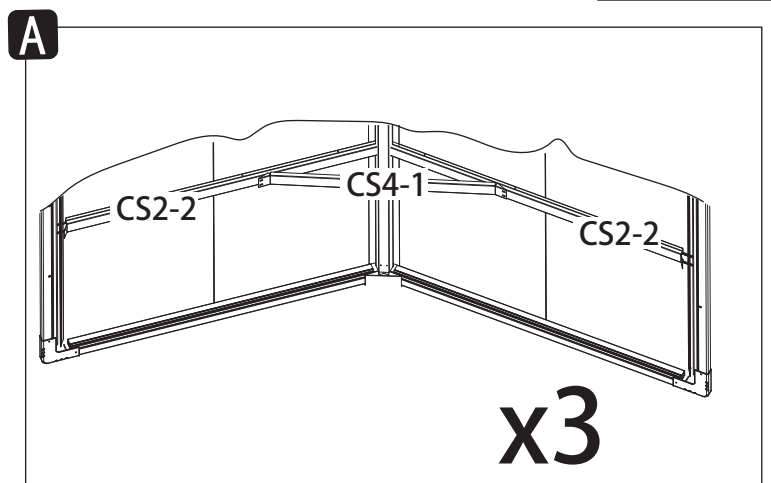
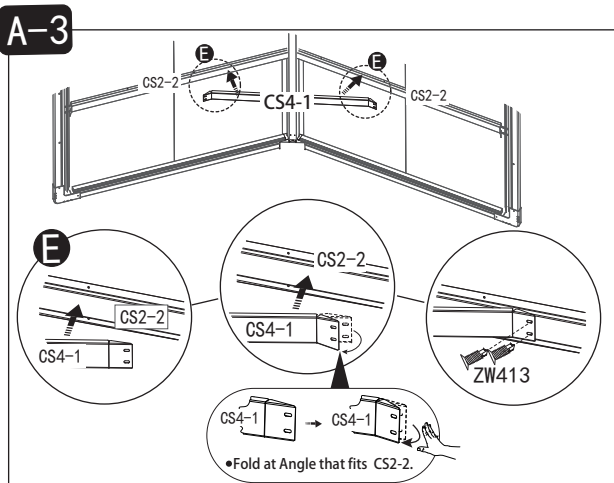
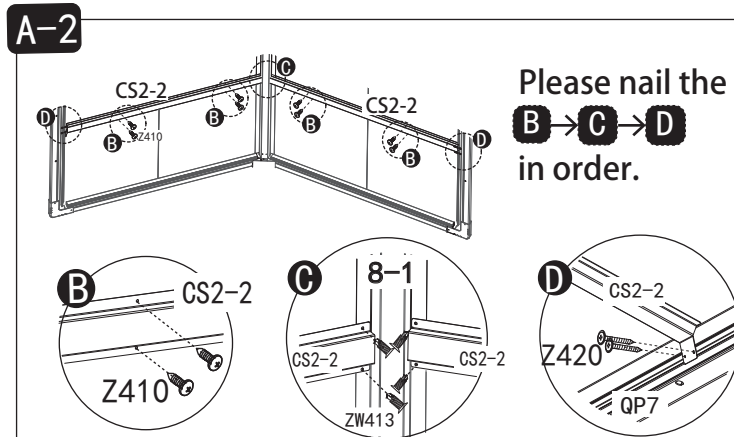
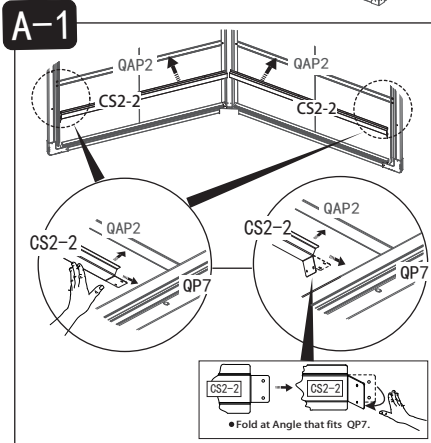

Step 30

30-1

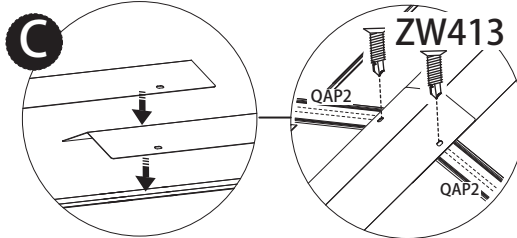
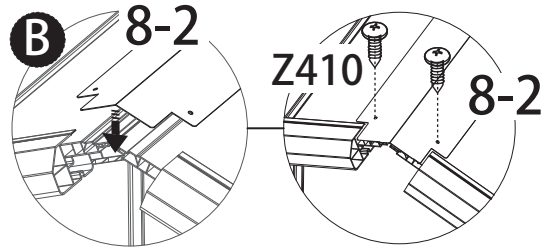
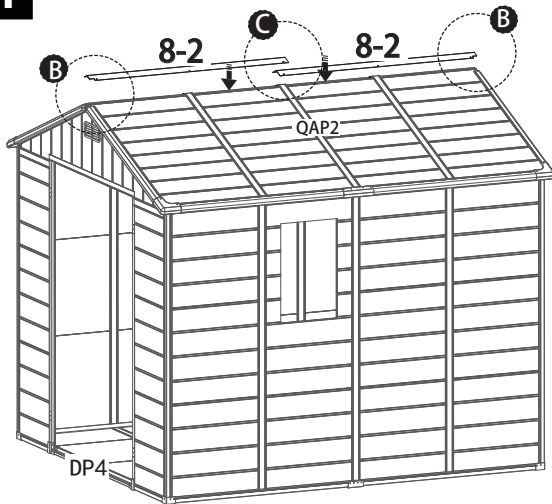

Attention to the location of the screws: they need to be locked on the iron pipe that corresponds to the inside of the plastic profile.

ZW413		6 PC
8-2		2 PC
Z410		4 PC
SG1		2 PC
Z425		4 PC

30-2

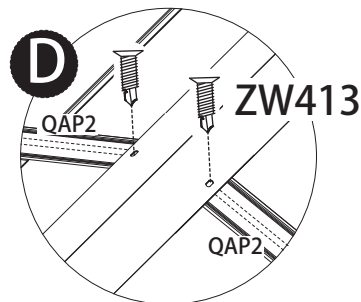
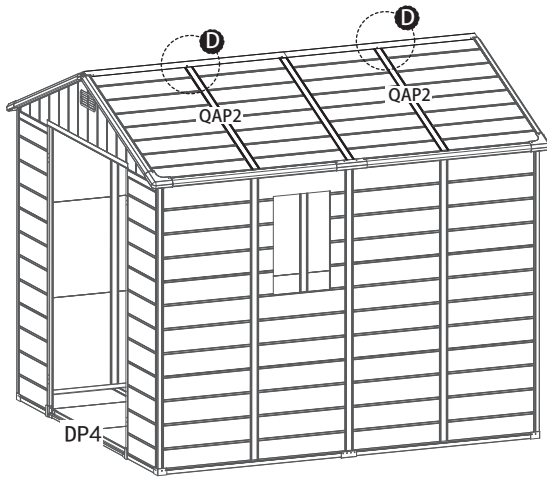

Attention to the location of the screws: they need to be locked on the iron pipe that corresponds to the inside of the plastic profile.

30-3

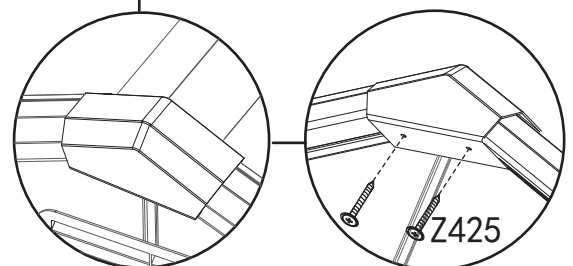
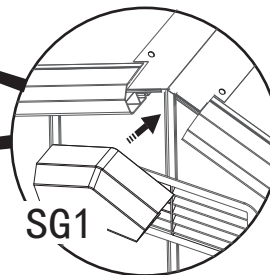
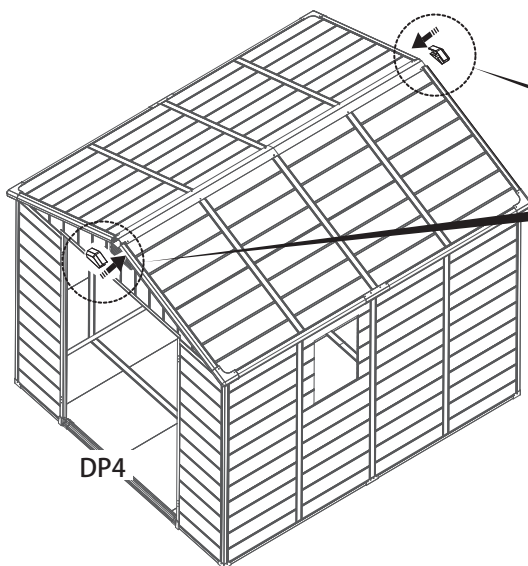

Step 31

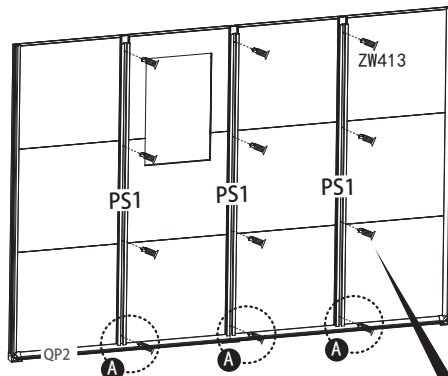
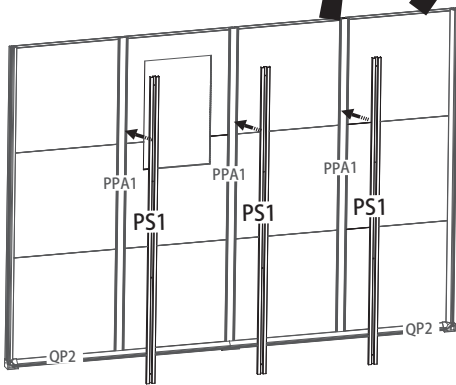
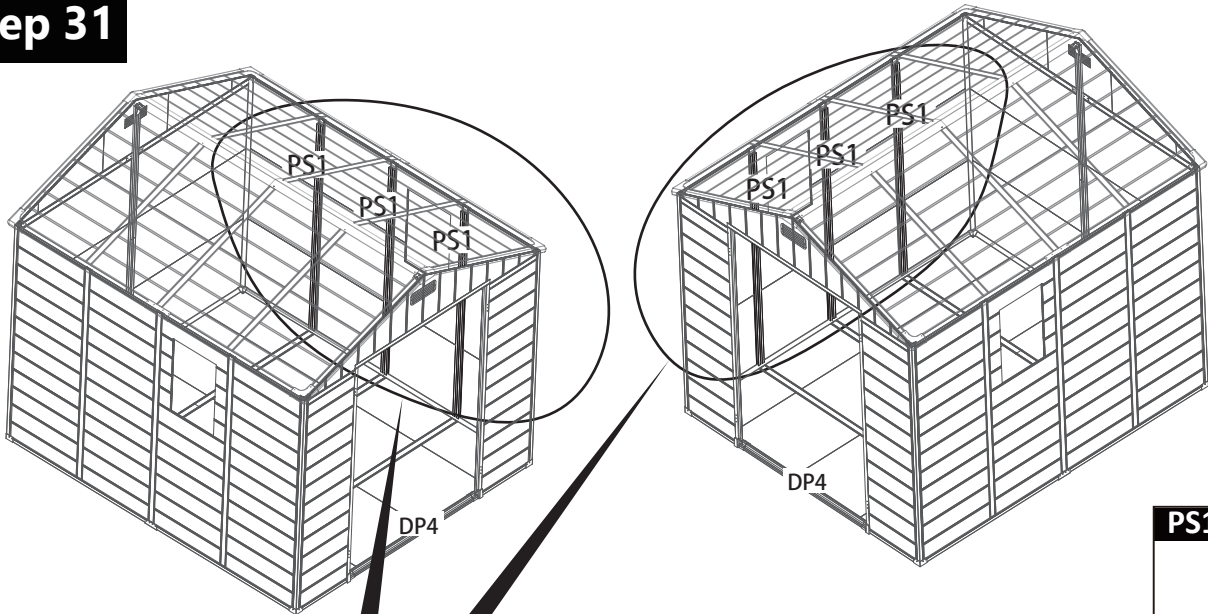

PS1
6 PC
ZW413
24 PC

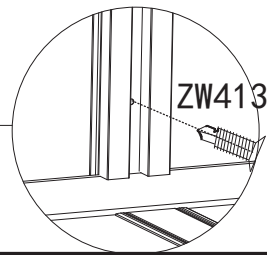
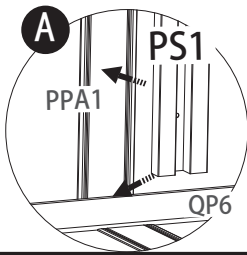

Attention to the location of the screws: they need to be locked on the iron pipe that corresponds to the inside of the plastic profile.

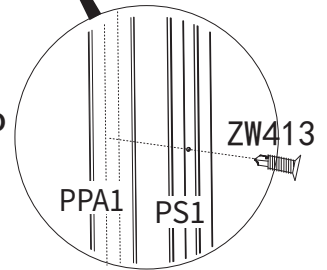

Step 32

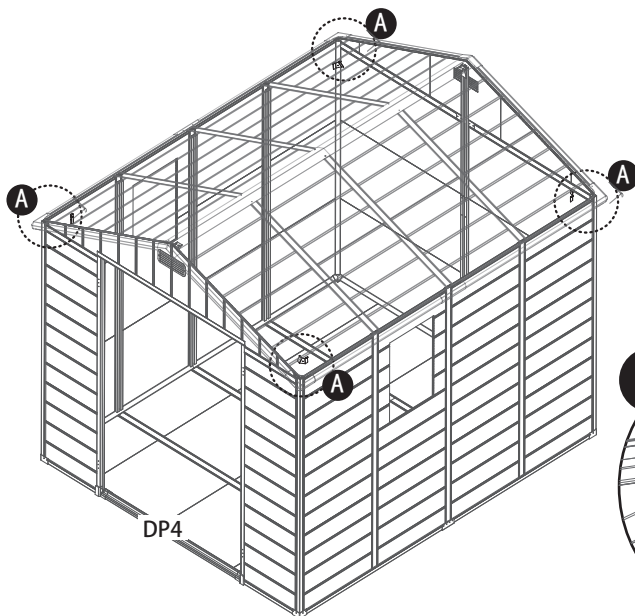

SG14
4 PC
Z420
4 PC

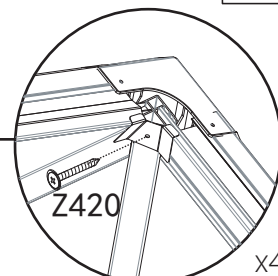
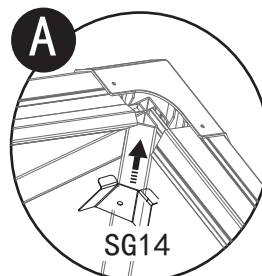

x4

Step 33

Window section

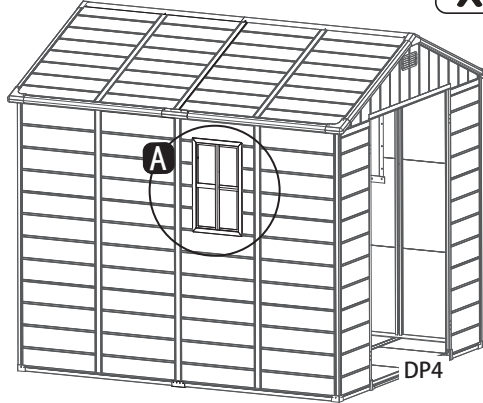
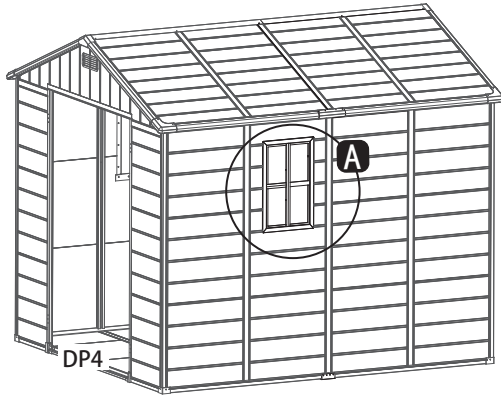
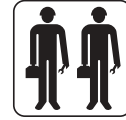

SG10



2 PC

SG101

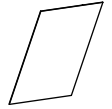

2 PC

SG102



2 PC

Z410



32 PC

A-1

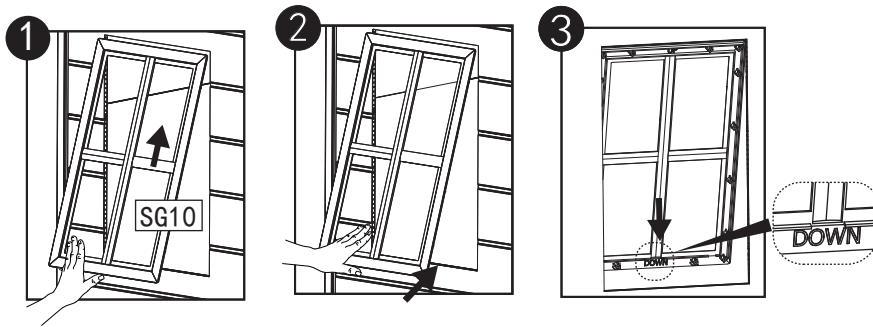

A-2

- Remove the film before fixing SG101

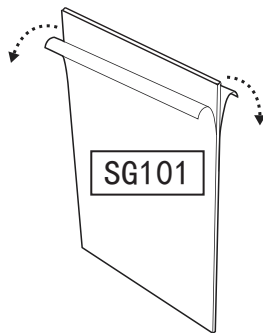

- Two persons are needed for this step, to press SG10 from outside and inside.

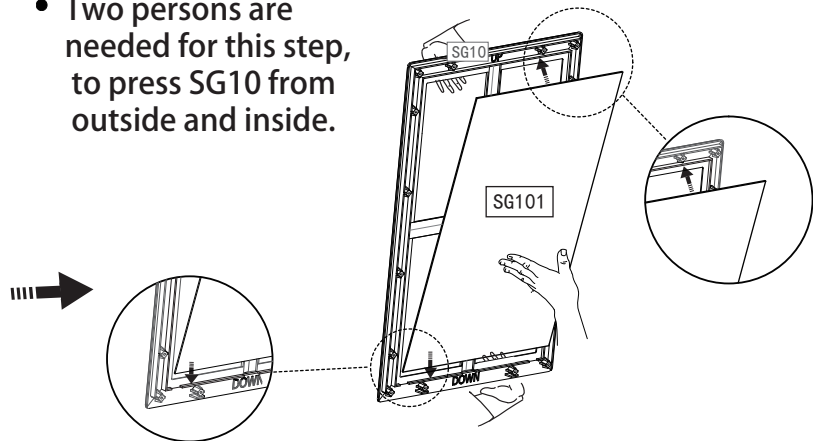

A-3

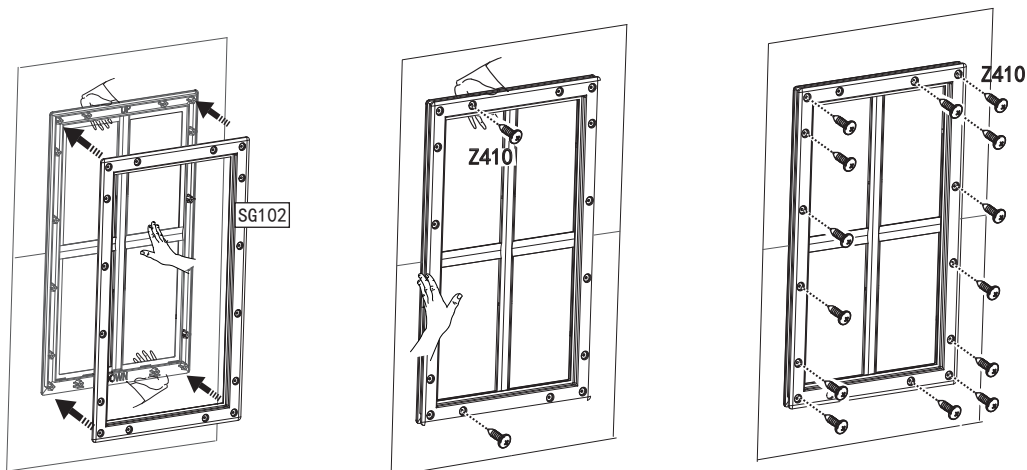

DOOR SECTION



Door mount this is above

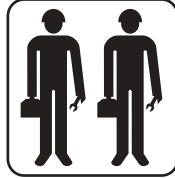

SG8

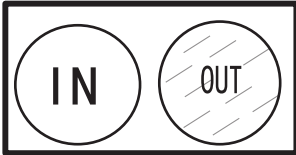
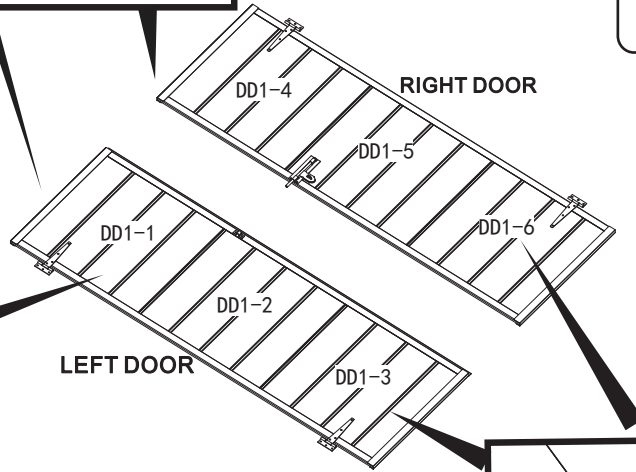
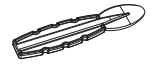

The stripes should be outside

The boards must be straight

Step 34

34-1

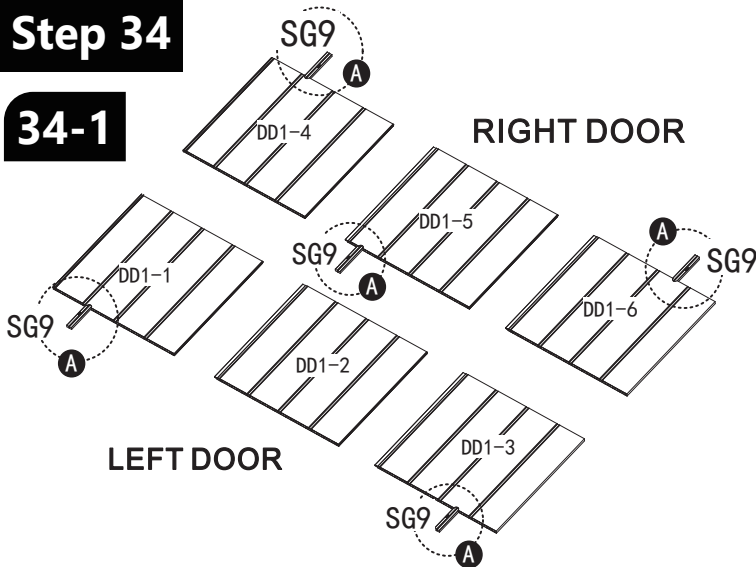

DD1-3 1 PC	DD1-2 1 PC
DD1-5 1 PC	DD1-6 1 PC
DD1-1 1 PC	
DD1-4 1 PC	
SG9 5 PC	

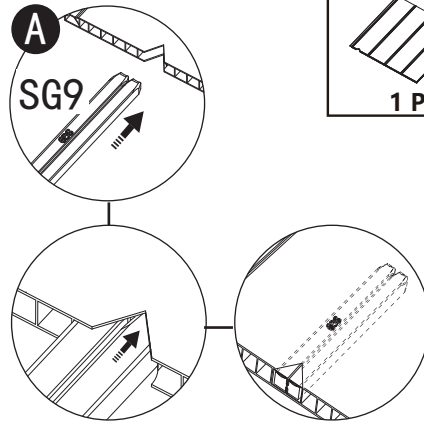

34-2

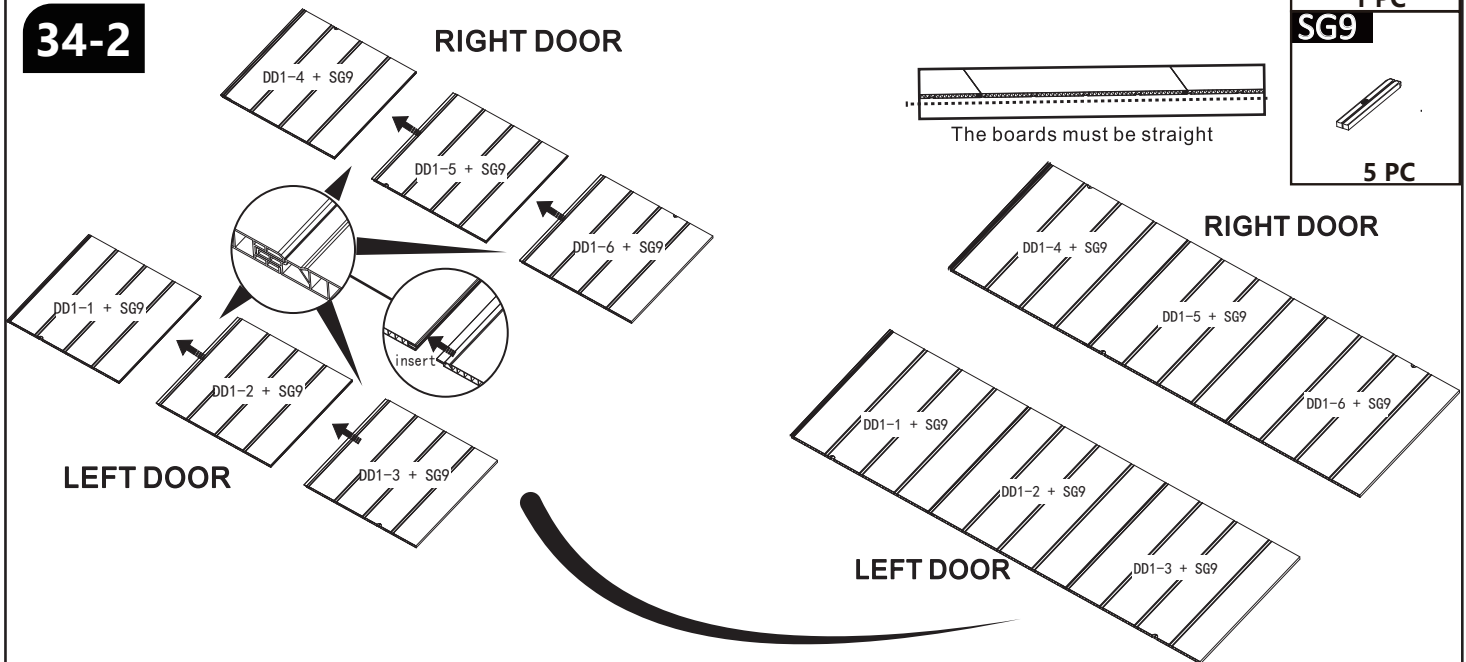

Step 35

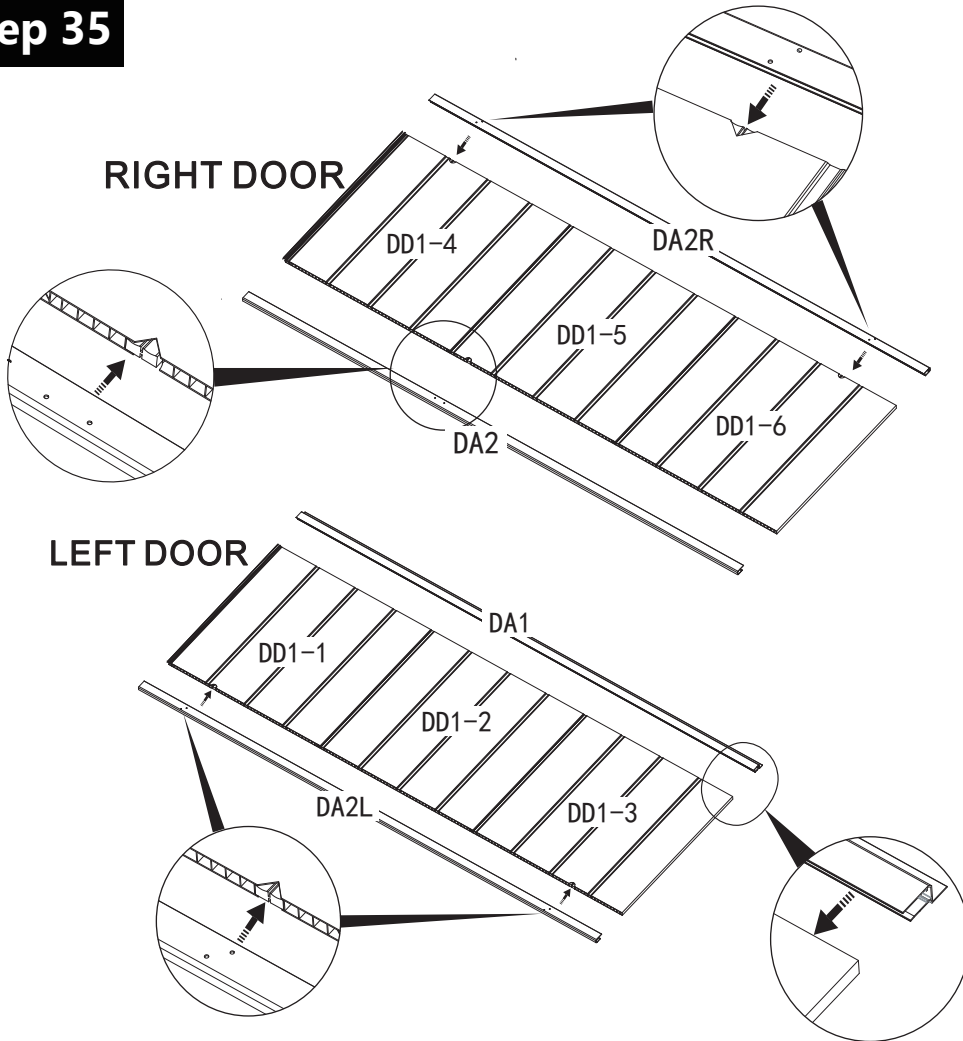

- DA2R**
1 PC
- DA2**
1 PC
- DA2L**
1 PC
- DA1**
1 PC

Step 36

LEFT DOOR

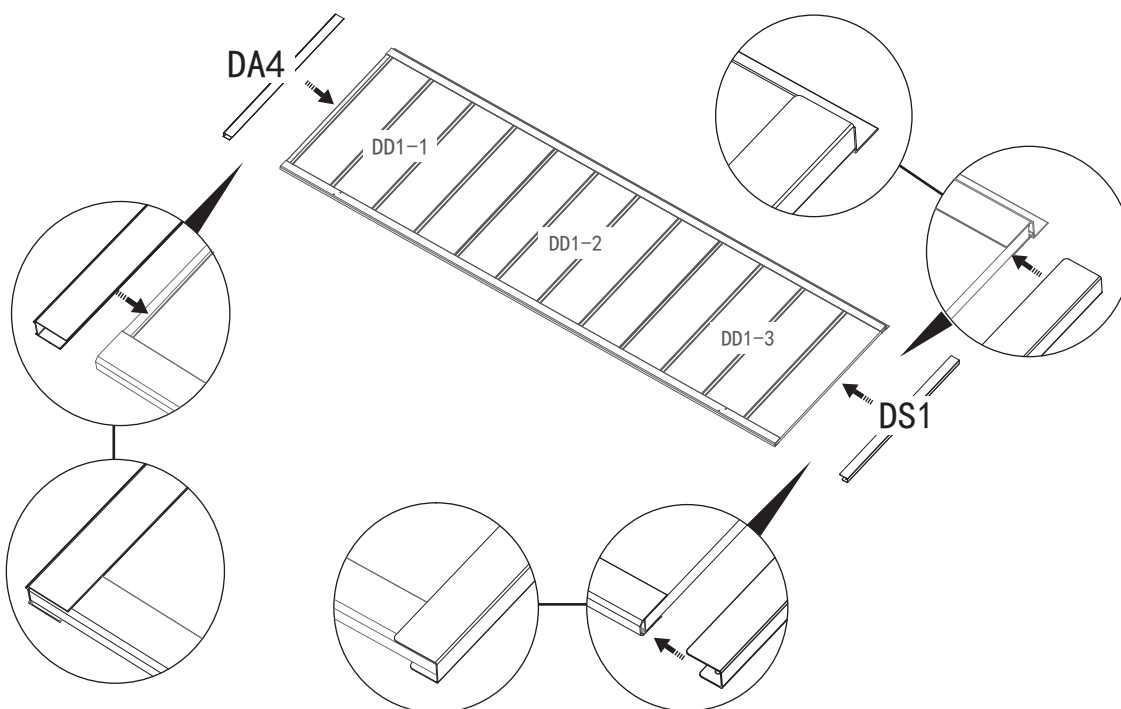



- DA4**
1 PC
- DS1**
1 PC

Step 37

RIGHT DOOR

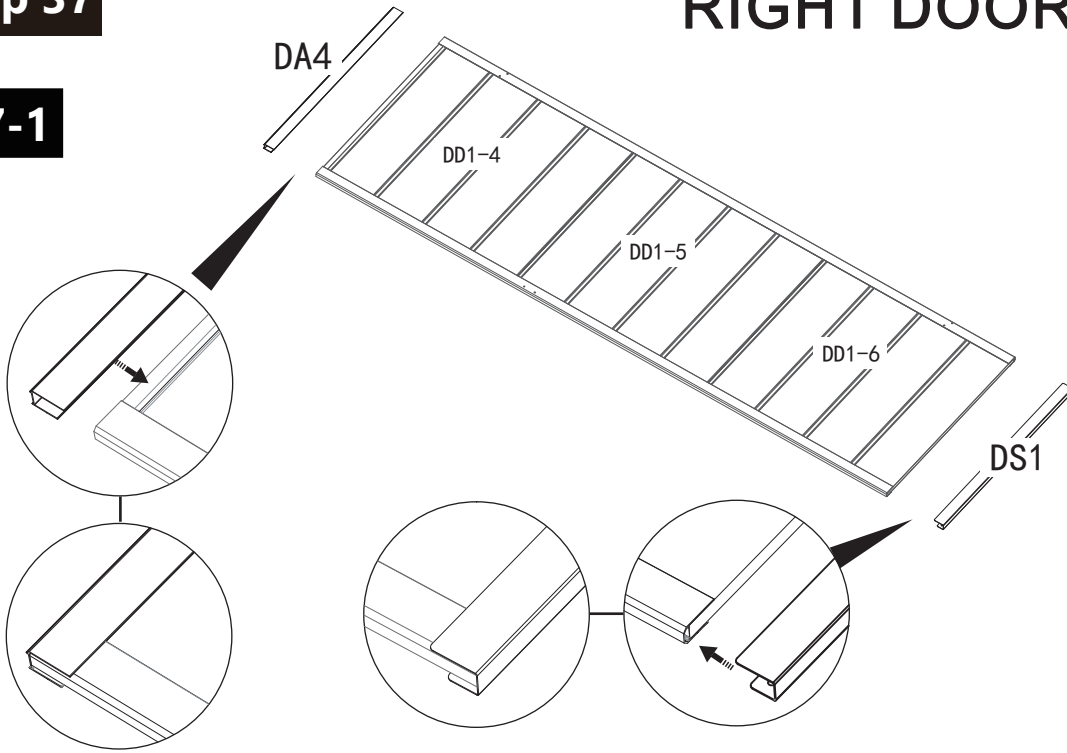
37-1



DA4

1 PC
DS1

1 PC

37-2

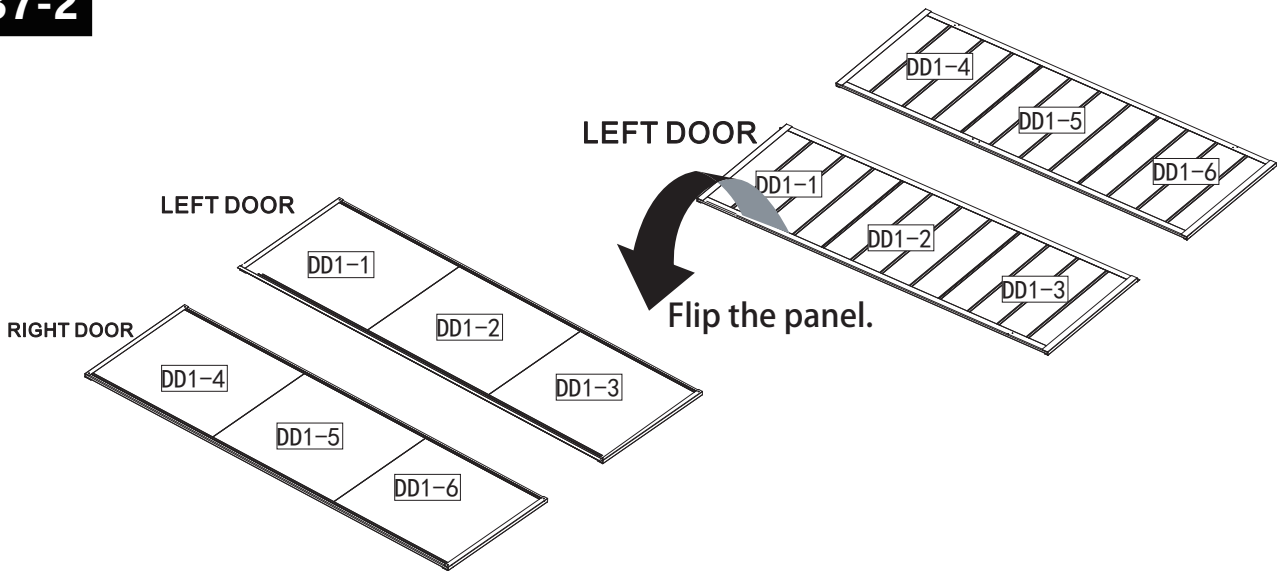
RIGHT DOOR

LEFT DOOR



37-3

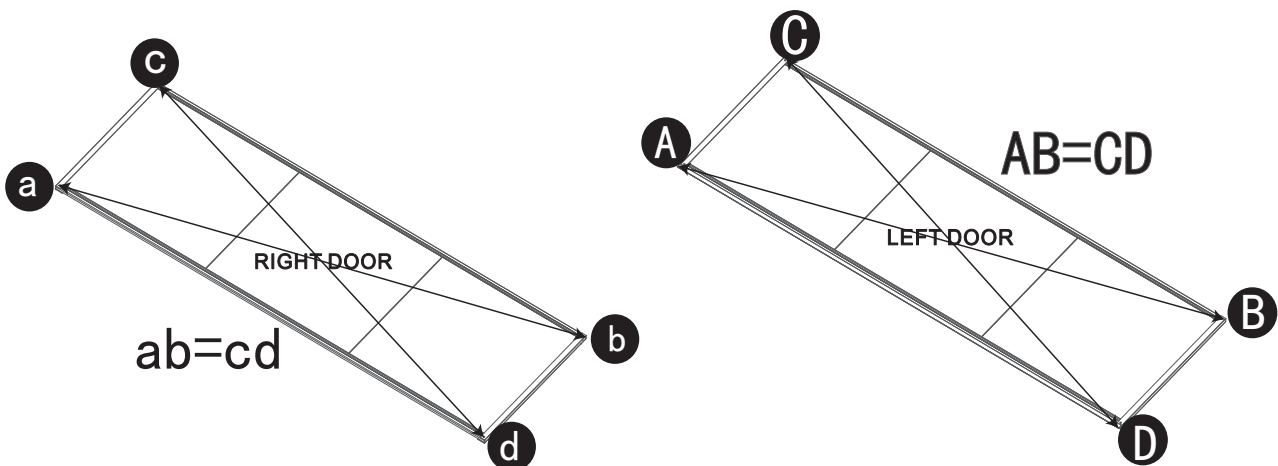

Step 38

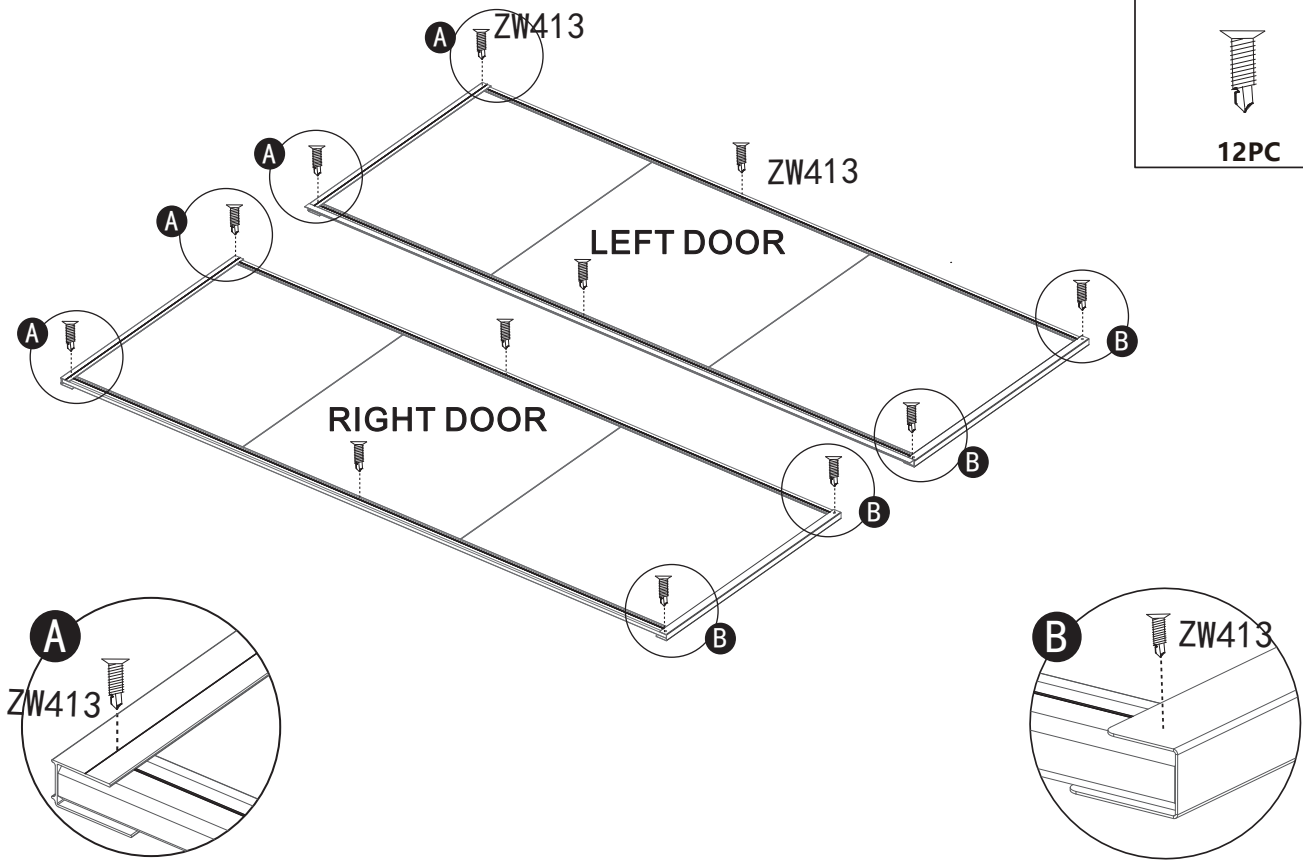

Step 39

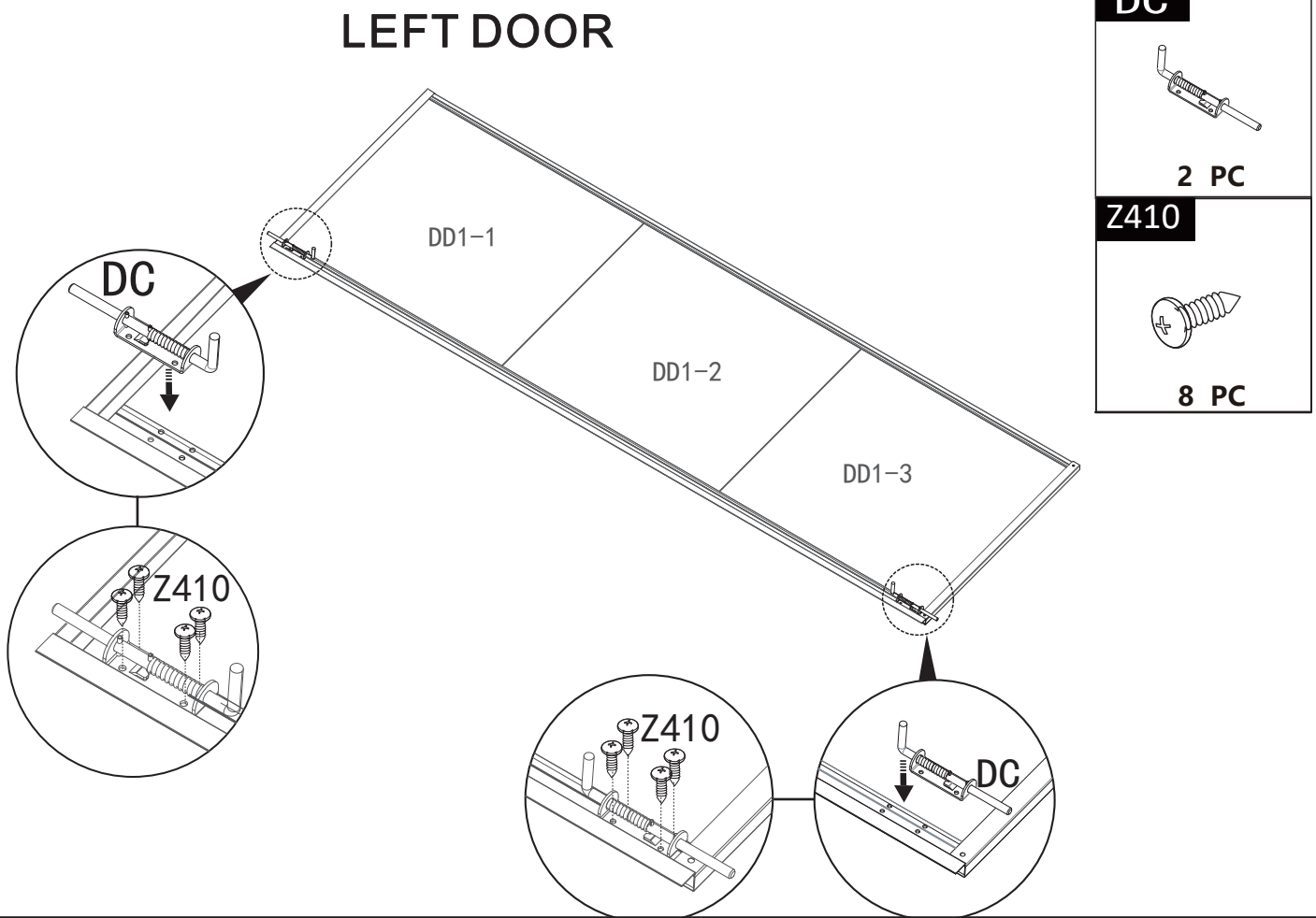

Step 40

40-1

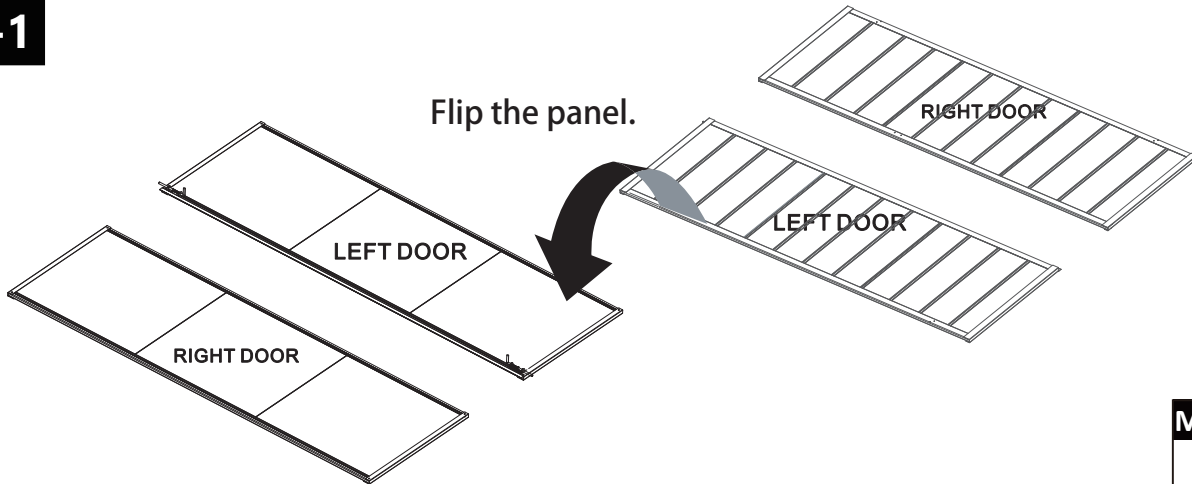

40-2

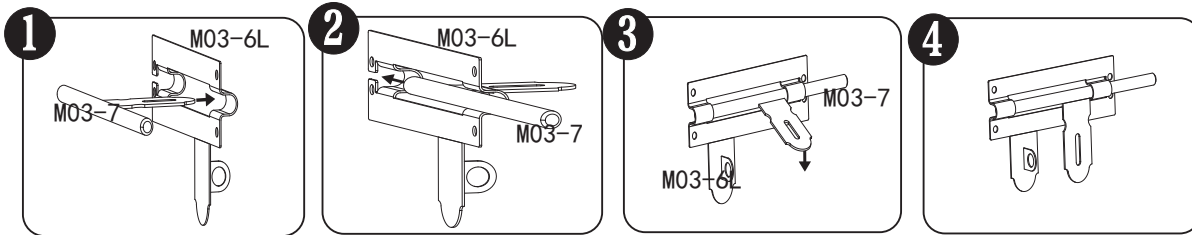

M03-6L		1 PC
M03-7		1 PC
Z410		12 PC
MO1		4 PC
		M03-6L + M03-7

40-2

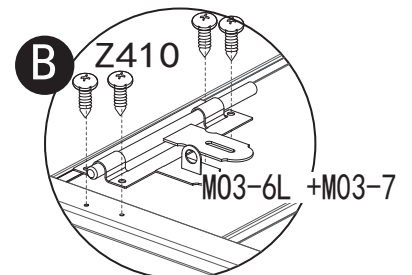
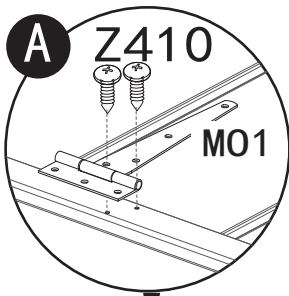
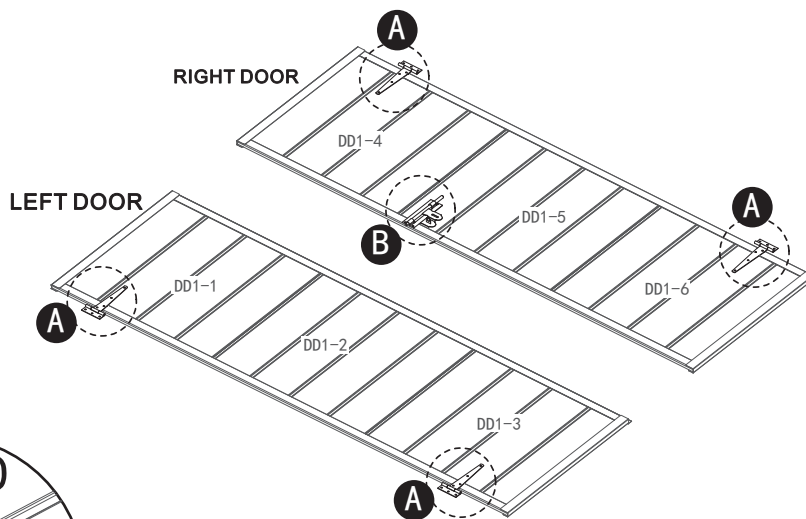

Don't fasten the screws in this step to adjust the positions of doors

Step 41

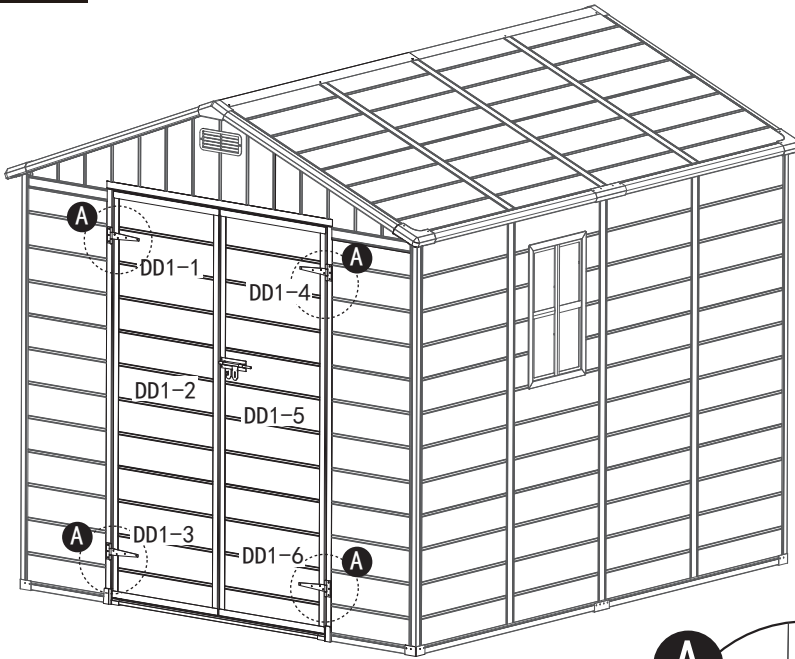

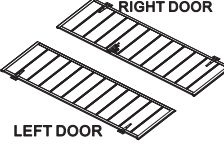
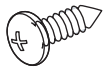

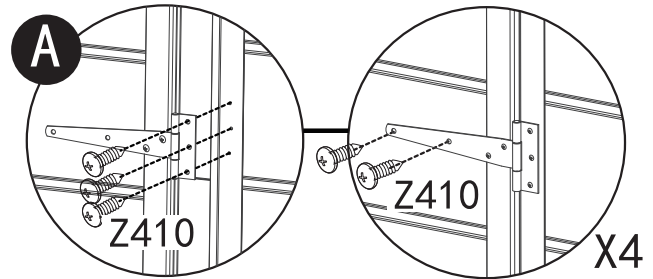
 <p>RIGHT DOOR LEFT DOOR</p>
Z410

20 PC

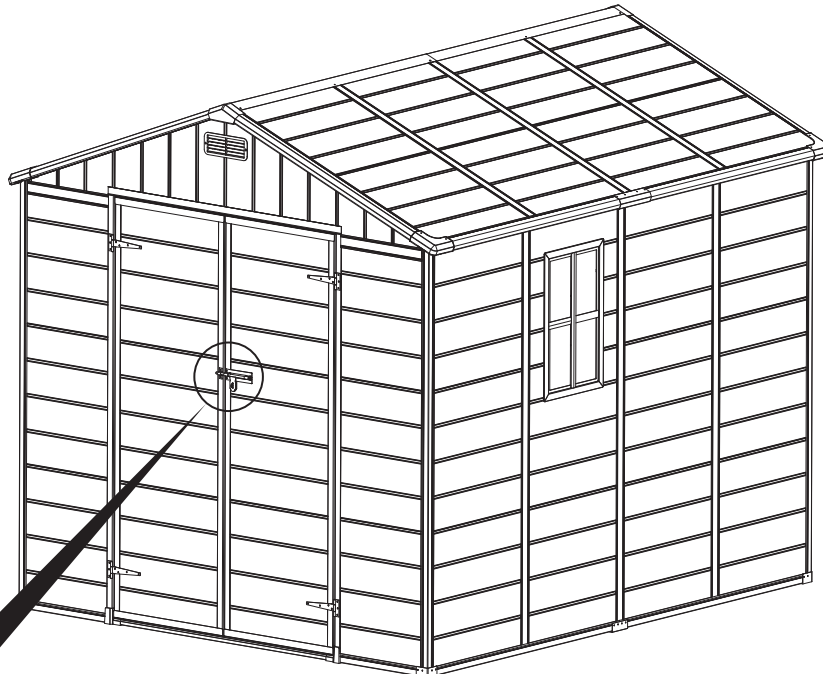

Nail the door after place adjustment and fasten all the screws.

Step 42



ZW413

2 PC
MO4

1 PC

