

Assembly Instructions

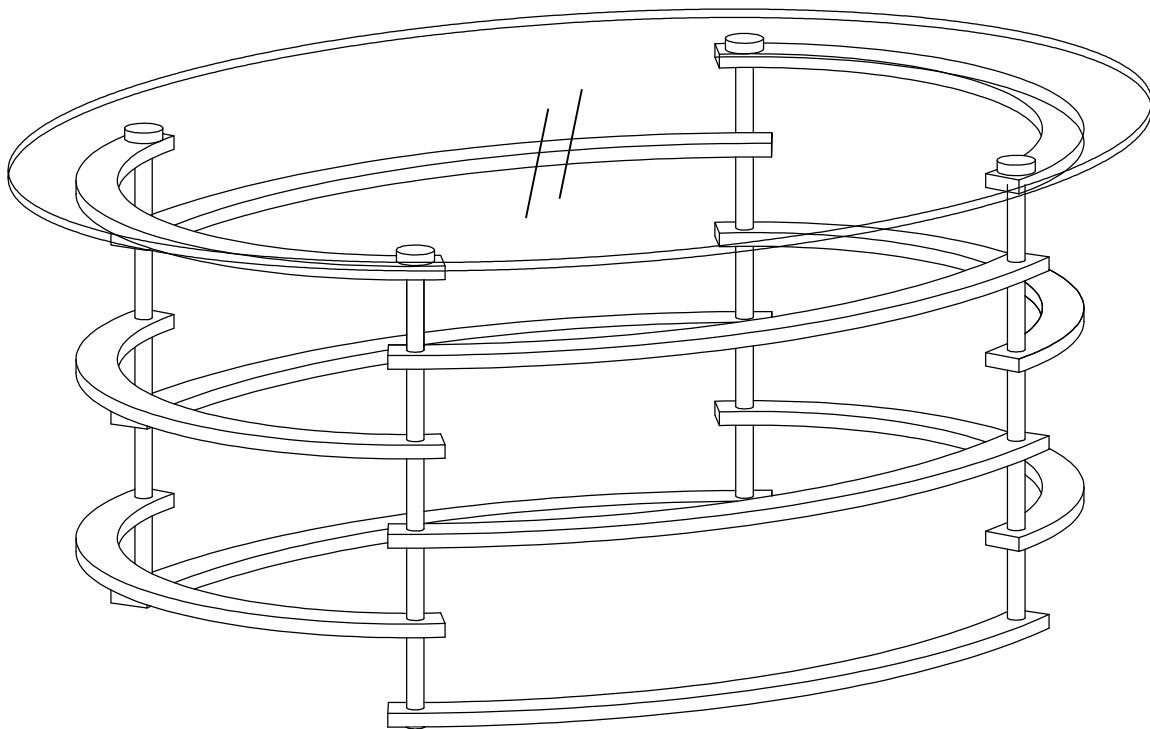

ASSEMBLY RATING

The Assembly Rating is a 5-point system that shows the degree of effort needed in assembling a specific product (with 1 being easy and 5 being difficult). For some products, two persons are recommended.

EASY



DIFFICULT

Tools Required For Assembly:

Allen Wrench

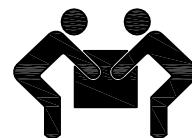
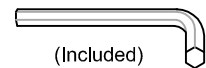

2 PERSONS RECOMMENDED

ASSEMBLY & CARE ADVICE

FOR YOUR FURNITURE TO LAST, CORRECT ASSEMBLY AND PROPER MAINTENANCE ARE NECESSARY. PLEASE FOLLOW THE INFORMATION PROVIDED BELOW TO FULLY ENJOY YOUR FURNITURE.

BASIC ASSEMBLY TECHNIQUES



When lock or spring washer is used in an assembly, please make sure the lock or spring washer is placed between the larger flat washer and the head of the screw or bolt.



Position each part correctly and insert screws or bolts into their respective holes by hand tighten or using the proper hand tool. Only tighten when step is completed or when instructed to do so.



Use cardboard or carpet area when assembling furniture to prevent scratches. Make sure the furniture rests on a flat and level surface with each leg evenly touching the floor.



Some furniture comes with height adjustment knobs underneath each leg. To lower or to raise each leg, you need to turn clockwise or counterclockwise, respectively.

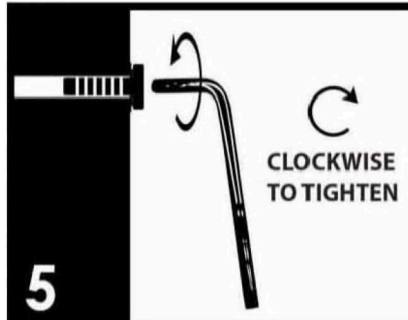

Make sure all parts are properly aligned, then use the appropriate hand tool to completely tighten the bolts or screws. Do not use power tools and do not overtighten.

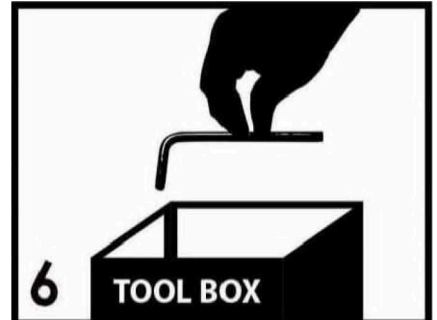

Save the instructions and store the Allen wrench or any supplied tool for later maintenance. After two weeks, check and tighten any loose hardware and repeat again every six months thereafter.

IT IS THE USER'S RESPONSIBILITY TO MAINTAIN THE FURNITURE. THE HARDWARE MAY LOOSEN OVER TIME AND MAY CAUSE THE FURNITURE TO BE WOBBLY AND UNABLE TO SUPPORT ITS INTENDED WEIGHT CAPACITY. THIS MAY LEAD TO COLLAPSE AND MAY CAUSE SERIOUS INJURY.



FAILURE TO FOLLOW THE GUIDELINES ABOVE MAY RESULT IN INJURY AND/OR PROPERTY DAMAGE.

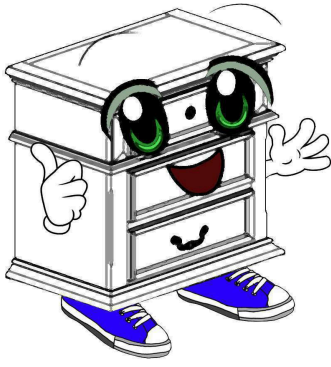

Before you begin, please read Page 2 of "Assembly and Care Advice".

And remember, do not tighten until each step is completed or instructed.

Parts List

Hardware List



#1 x 1pc
Glass Top



#A x 6pcs
Foot pad

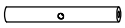

#2 x 20pcs
Support Bar A

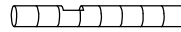

#B x 20pcs
Screw Bolt 1/4"*1"

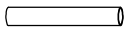

#3 x 20pcs
Support Bar B

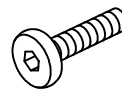

#C x 4pcs
Bolt 1/4"*1-1/4"



#4 x 6pcs
Shelf



#D x 1pc
Allen Wrench



#5 x 4pcs
Middle Shelf



#6 x 2pcs
Bottom Shelf



#1

2. Insert the screw bolt (#B) into each support bar (#2), turn right to tighten. Then insert the other end of the bolt into the shelf, insert the wrench into the hole along the bar to secure.

#B x 4pcs

3. Place the support bar (#3) onto the support bars (#2).

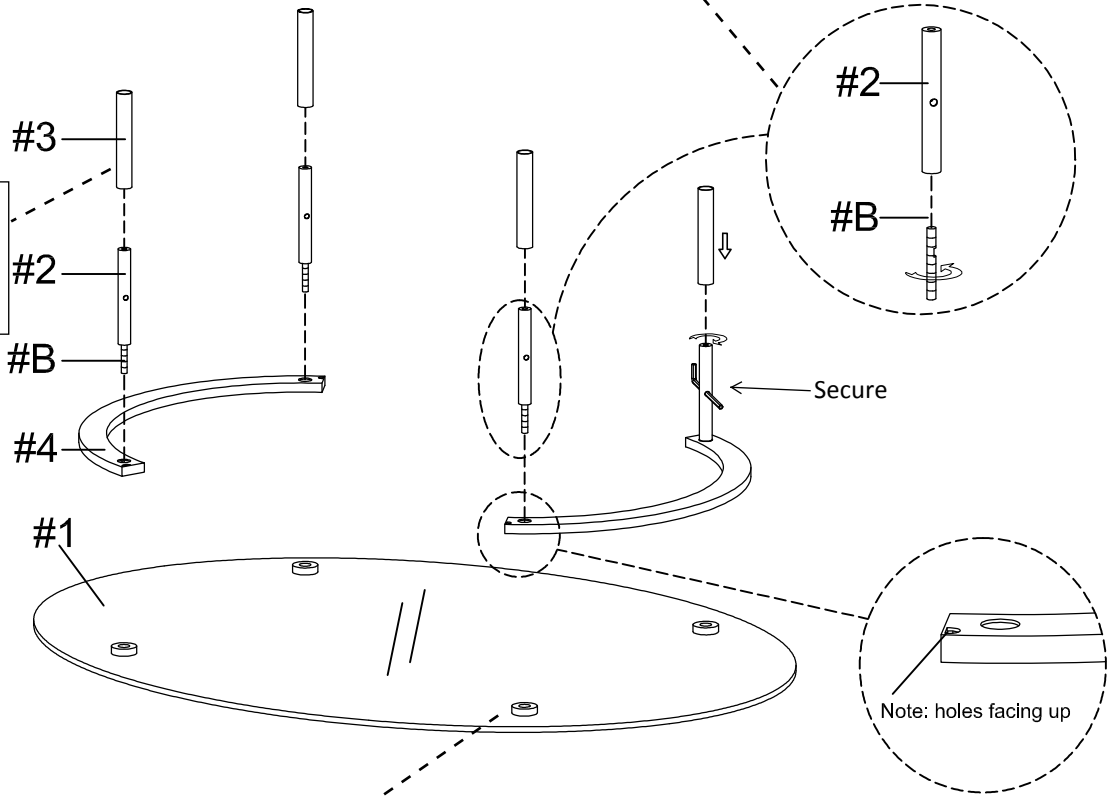

1. Align the shelf (#4) to the glass top (#1).



#2

#B x 4pcs

3. Place the support bar (#3) onto the support bars (#2).

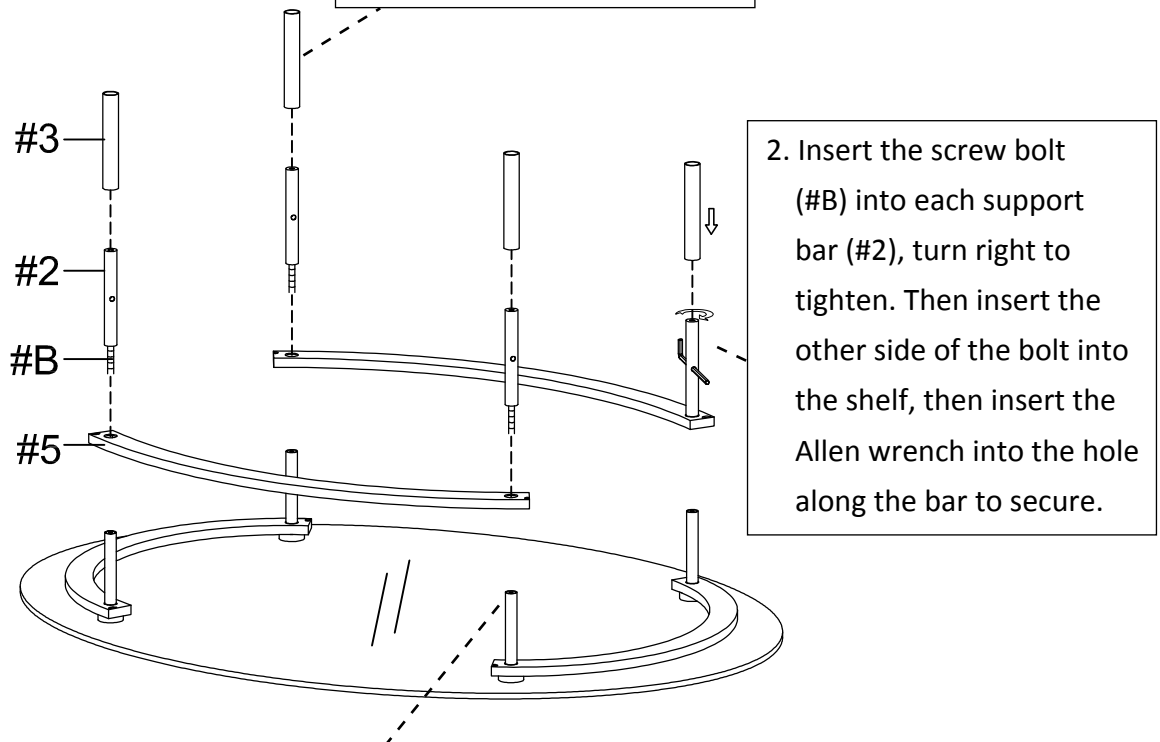

1. Align the middle shelf (#5) to the top of the bars.



#3

#B x 4pcs

3. Place the support bar (#3) onto the support bars (#2).

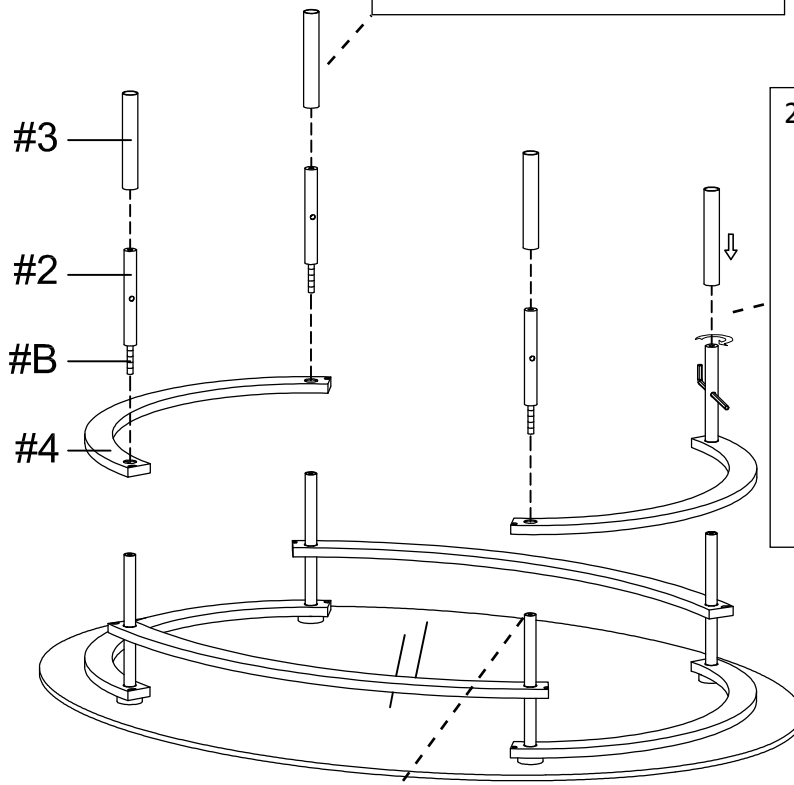

2. Insert the screw bolt (#B) into each support bar (#2), turn right to tighten. Then insert the other side of the bolt into the shelf (#4), then insert the Allen wrench into the hole along the bar to secure.

1. Align the shelf (#4) to the top of the bars.



#4

#B x 4pcs

Repeat step #2.

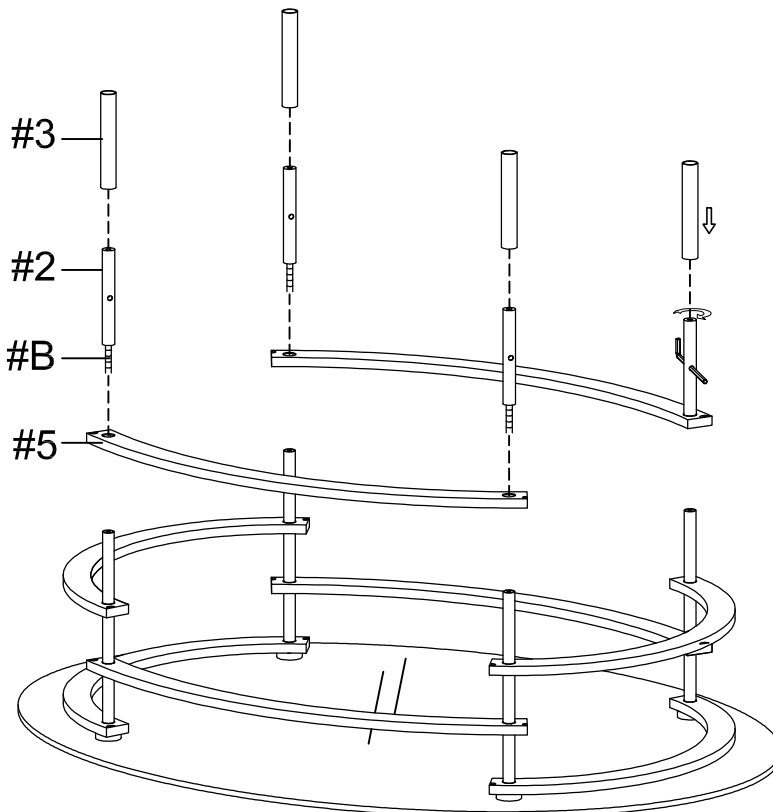



#5

#B x 4pcs

Repeat step #3.

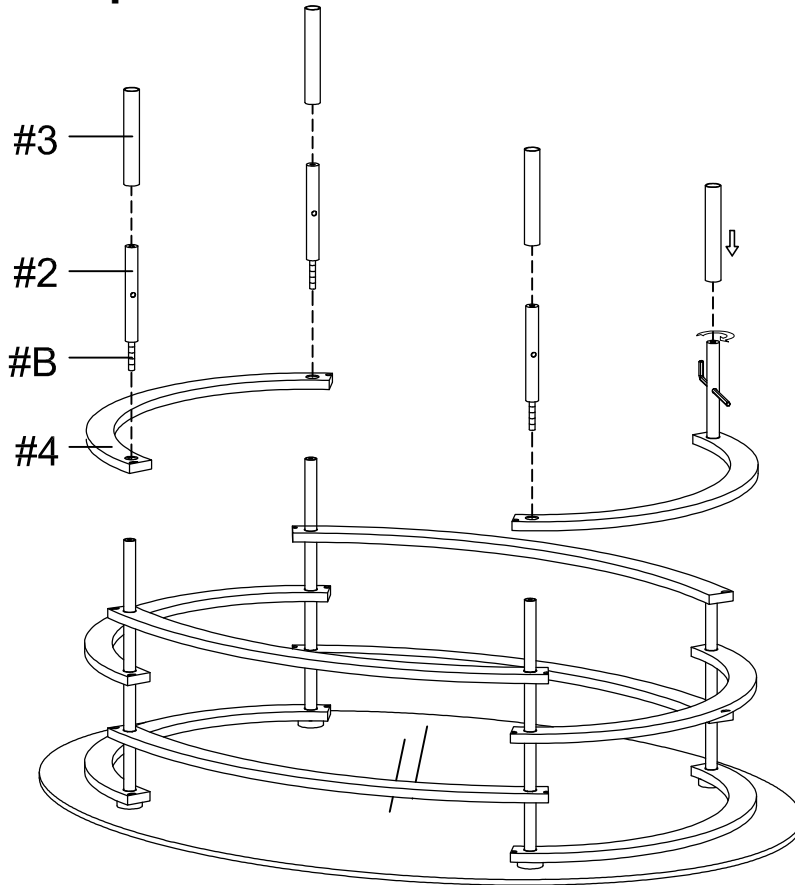

#6

#A x 6pcs
#C x 4pcs

Align the bottom shelf (#6) to the bottom ends of the bars, then insert the bolts (#C) into the inner holes and secure. Insert the foot pads (#A) into the outer holes.

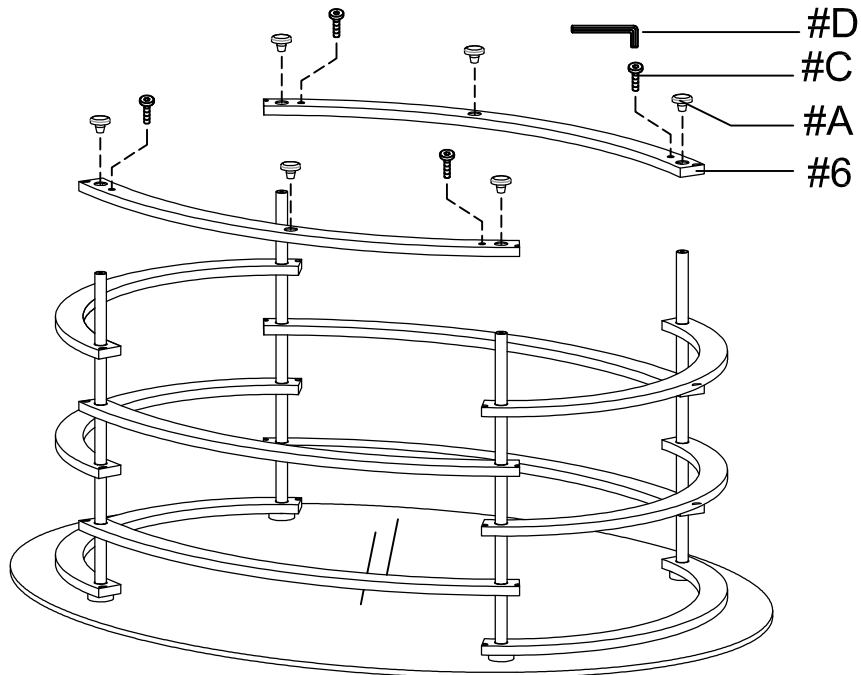



Make sure all parts are firmly secured.

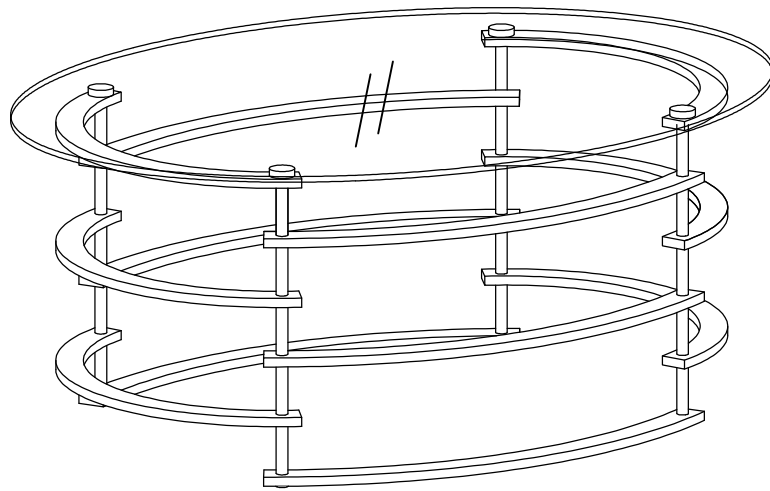

ASSEMBLY IS COMPLETED