







## CARE AND MAINTENANCE

Spot clean using a mild water-free solvent. Only a professional cleaner should undertake a complete overall cleaning.  
The use of steam or water-based cleaners may cause excessive shrinking or staining.

## NOTICE

- \* Please make sure that you have all parts indicated before you begin assembly of this item
- \* This item should be assembled on a soft surface to prevent scratching the finish during assembly
- \* This item may require periodic tightening

## Part List and Hardware List

PIECE	DESCRIPTION	PICTURE	QUANTITY
A	SEAT		1X
B	LEGS		4X
C	Spring washer(M8)		12X
D	Metal Gasket(M8)		12X
E	Bolt(M8*35mm)		12X
F	Allen key		1X

Dimensions:33.46"WX31.69"Dx40.94"H

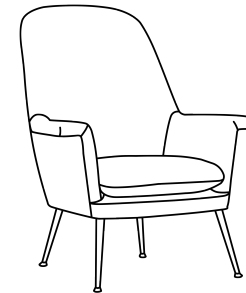

Weight Capacity: 275 lbs

**WARNING: DO NOT STAND ON CHAIR**

**WARNING: DO NOT OVER TORQUE BOLTS/SCREWS**

**The legs and hardware are on the top of the chair.**

## PREPARATION

Before beginning assembly of product, make sure all parts are present. Compare parts with package contents list and hardware contents list.

If any part is missing or damaged, do not attempt to assemble the product.

Estimated Assembly Time: 10 minutes.

Tools Required for Assembly (included): Allen key

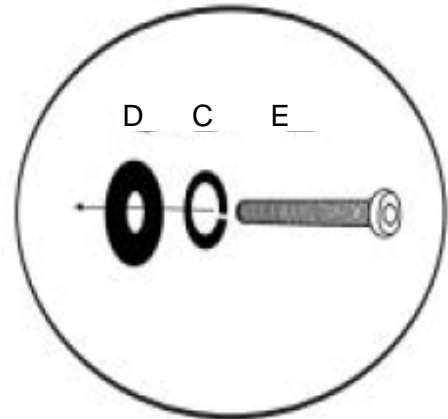
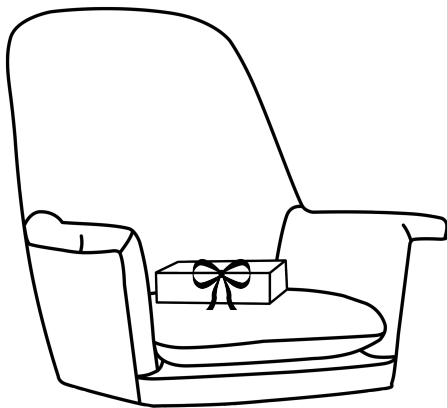

**STEP1** THE LEGS IS ON THE TOP OF THE CHAIR, OPEN TO TAKE THE LEG AND HARDWARE(THE ROPES ON THE CARTON HAVE NO OTHER USE, THEY ARE ONLY USED FOR TYING LEGS)

**STEP2** PUT THE WASHERS ON THE BOLT IN THE ORDER SHOWN IN THE PICTURE

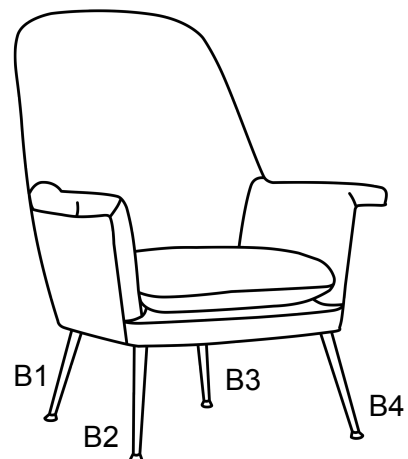
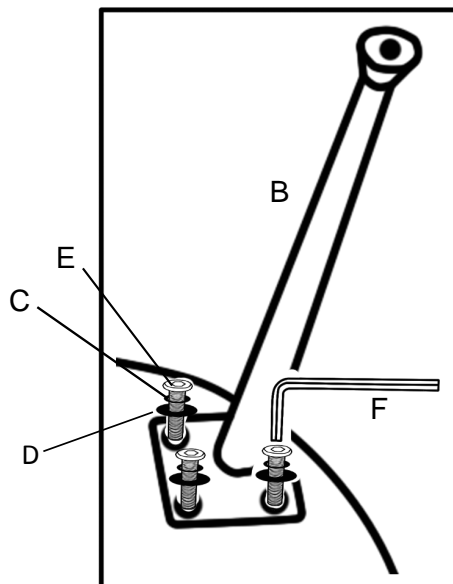

**STEP3** INSERT THE LEGS AND SCREW IN THE BOLTS BUT DON'T TIGHTEN COMPLETELY.

**STEP5** PUT THE CHAIR UPRIGHT AND MAKE SURE ALL LEGS ARE LEVEL, THEN FIRMLY TIGHTEN BOLTS WITH ALLEN KEY WHILE THE CHAIR IS UPRIGHT AS PICTURED ABOVE(IF THE CHAIR WOBBLY, YOU CAN EASY ADJUST LEG BOTTOM PLASTIC SCREW)

**The legs and hardware are on the top of the chair.**