

SIGNATURE SERIES BOOK SHELF RACK SPR3



If you need assistance, please call 1-877-ENCLUME
Enclume Design Products
24 Colwell Street, Port Hadlock, WA 98339

Enclosed you will find everything needed for the assembly and use of your bookshelf rack. Two people make assembly and installation easier. The parts and hardware included are:

Hardware included:

- 2 – 3/8" x 1" Button Head Screws
- 4 – 2" Lag Screw
- 1 – 7/32" Allen Wrench
- Toggle Kit (Drywall anchors)

Components included:

- 1 – Rectangular Base with Wood Front
- 2 – Arms
- 3 – Grid Brackets
- 1 – Grid
- 12 – Angled Pot Hooks
- 6 – Straight Pot Hooks

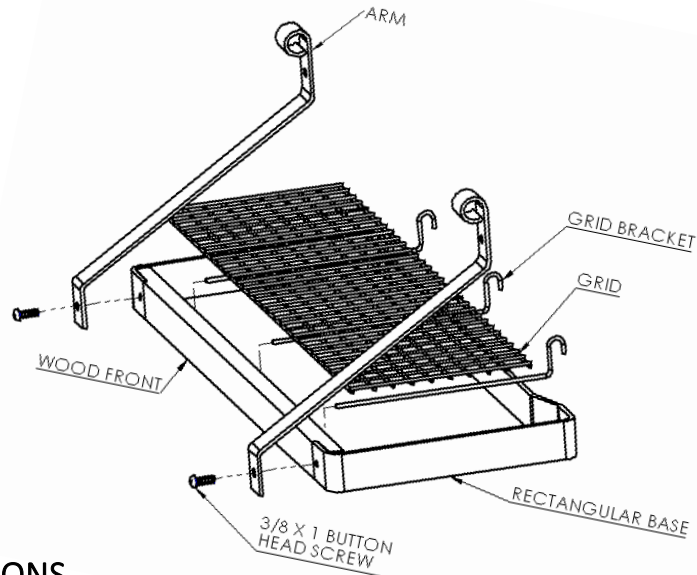

ASSEMBLY AND INSTALLATION INSTRUCTIONS

Rack Assembly

- 1) Remove one of the 3/8" x 1" button head screws from one side of the front of the rack. Place one of the arms in front of the hole and using the button head screw, attach the arm to the front of the rack carefully screwing through the steel of the end of the rack and into the wood. Repeat on the other side.
- 2) We recommend that you anchor your rack into the solid wood of wall studs. Carefully measure the area where the rack is to be hung and install the lag screw directly into the wood studs. If it is not convenient to hang your rack directly into wood you may use the included DRYWALL anchors included in the toggle pack enclosed with your rack. See Toggler® brand manufacturer recommendations for weight limits included in the instructions in the Toggle kit.
- 3) After the rack has been mounted onto the wall, place the grid brackets perpendicular to the rack inserting into the pre-existing holes in the wood and placing the other end over the back of the rack.
- 4) Distribute the weight of your cookware evenly around the rack and grid.

WARNING: It is important that your bookshelf rack is assembled correctly. If the unit is assembled or used incorrectly, it could become unstable and collapse, possibly causing injury.

LIMITED WARRANTY: This product is warranted to be free of material defects, other than that from normal use, for a period of five years from the date of purchase. Customer's exclusive remedy shall be the repair or replacement of the defective product and shall be subject to the following conditions: (1) notice of any defect is received by Enclume within the warranty period and (2) customer returns the defective product to Enclume Design Products, 24 Colwell St., Port Hadlock, WA 98339, postage prepaid within 20 days following a return authorization number (which may be obtained by telephoning the number at the top of this instructions) being provided to the customer by Enclume. There are no other warranties, expressed or implied. THERE ARE NO WARRANTIES OF MERCHANTABILITY OR FITNESS FOR A PARTICULAR PURPOSE. ENCLUME SPECIFICALLY DISCLAIMS ANY AND ALL INCIDENTAL OR CONSEQUENTIAL DAMAGES ARISING OUT OF THE PURCHASE OR USE OF ENCLUME'S PRODUCTS.