

Kitchen Island

IMPORTANT

Carefully remove all the parts from the carton and place them individually on a soft cloth to prevent scratches or other damage.

Carefully and strictly follow these assembly instructions to ensure a completed product as designed.

Do not use power tools above 8 volts to assemble.

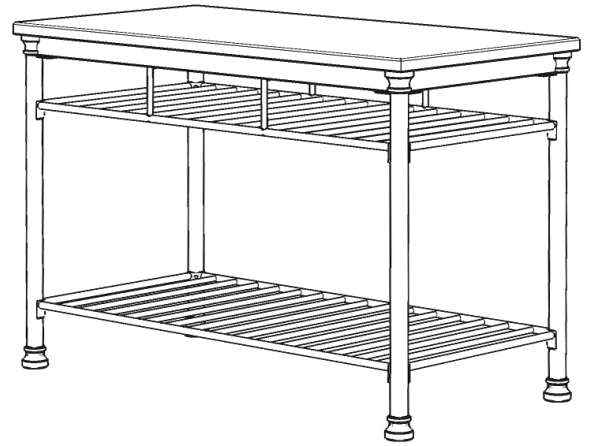

Part List

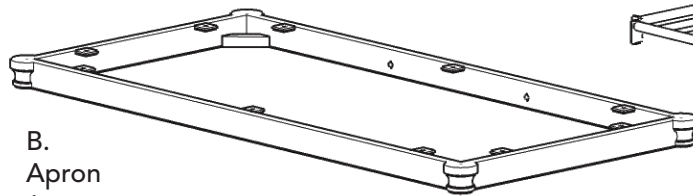

B.
Apron
1 pc.

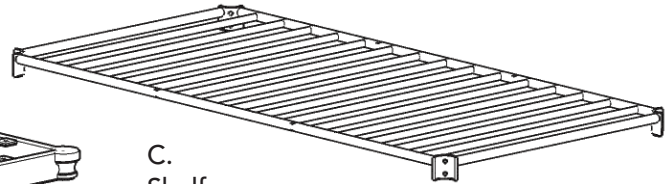

C.
Shelf
1 pc.

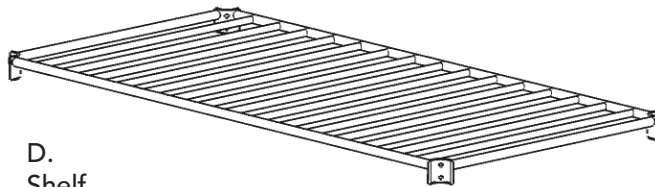

D.
Shelf
1 pc.



E.
Support
4 pcs.

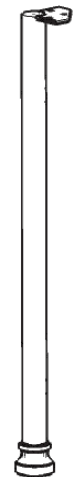

F.
Post
4 pcs.

Hardware List

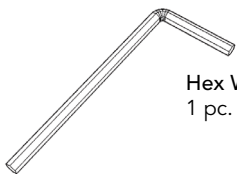

Hex Wrench
1 pc.



Spring Washer
14 pcs. (+1 extra)



M6x19
Head Cap Bolt
14 pcs. (+1 extra)



M6x19
Head Cap Bolt (short)
28 pcs. (+1 extra)



Small Hex Wrench
1 pc.



Flat Washer
14 pcs. (+1 extra)

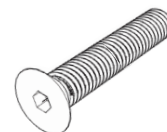

M6x32
Head Cap Bolt (long)
4 pcs. (+1 extra)

Carton is also needed for assembly.

Tool(s) required for assembly: Level

Assembly Instructions 2/3

IMPORTANT

- Use a soft cloth between these parts and the floor.
- Do not use power tools above 8 volts to assemble.
- Do not tighten all the bolts until each part is properly assembled.
- The unit must be level to work properly. Use the included adjustable levelers to level.
- Keep Hex Wrench in a safe place as the bolts may need to be tightened up in the future.

STEP 1

Place Top (A) upside down on a soft cloth.

Attach Apron (B) to Top (A) with Flat Washers, Spring Washers and Head Cap Bolts, tightening bolts only half way. (See Figure 1)

Tighten all Head Cap Bolts used in this step.

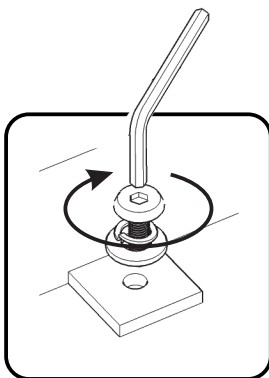
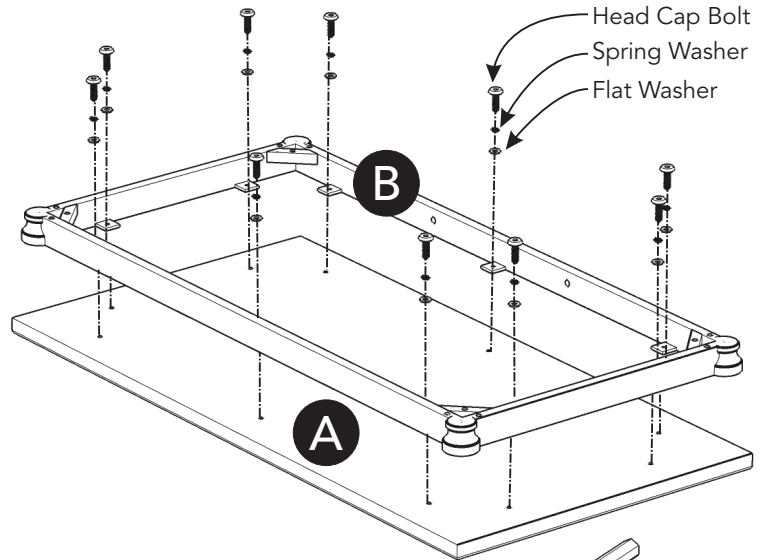

Figure 1

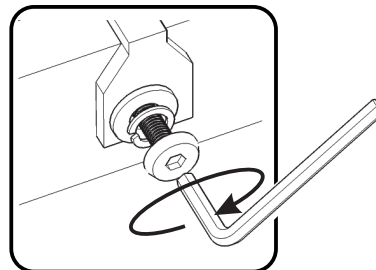

Figure 2

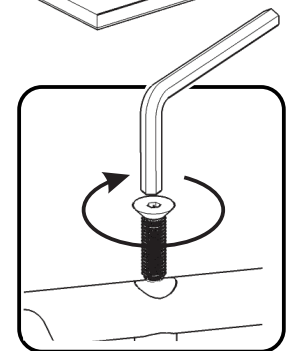
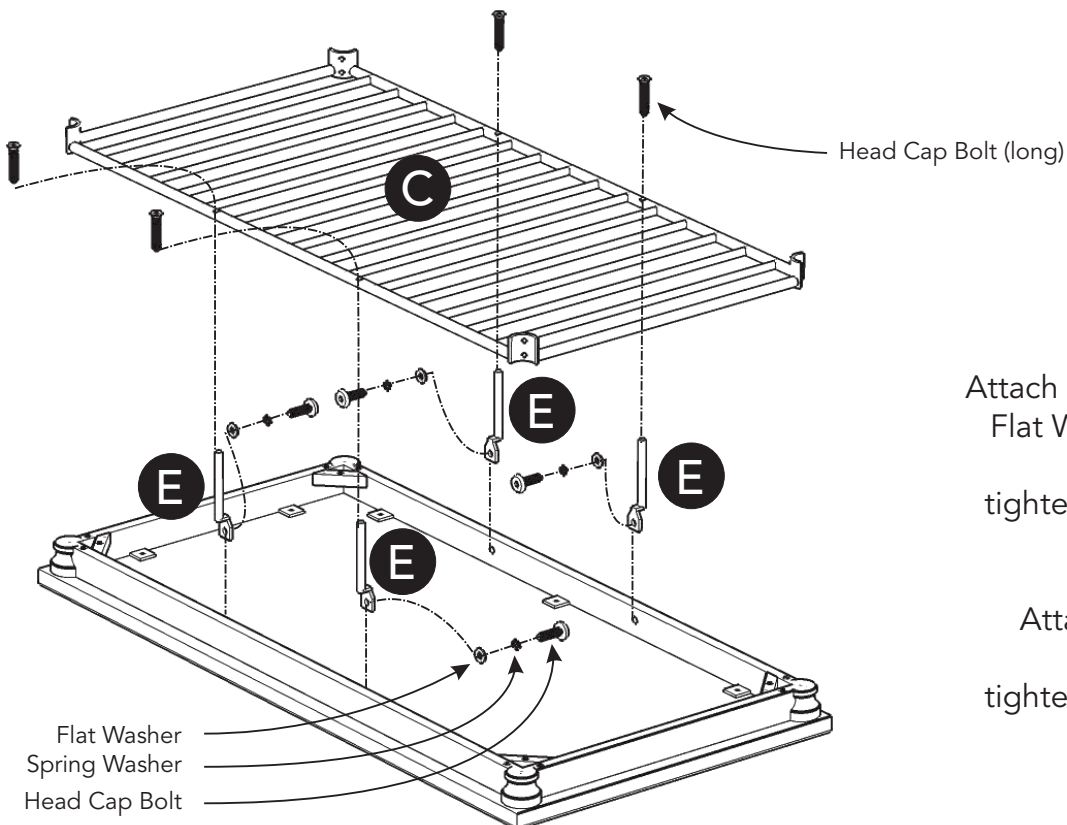

Figure 3



STEP 2

Attach Supports (E) to unit with Flat Washers, Spring Washers and Head Cap Bolts, tightening bolts only half way. (See Figure 2)

Attach Shelf (C) to unit with Head Cap Bolts (long), tightening bolts only half way. (See Figure 3)

Assembly Instructions 3/3

STEP 3

Attach Posts (F) to unit with Head Cap Bolts (short), tightening bolts only half way. (See Figures 4 and 5)

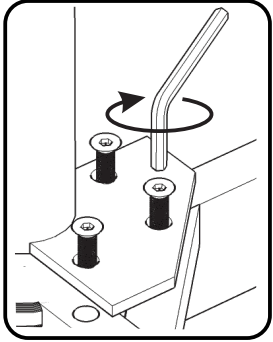

Figure 4

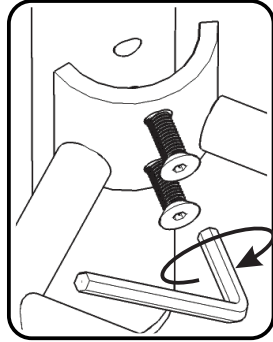
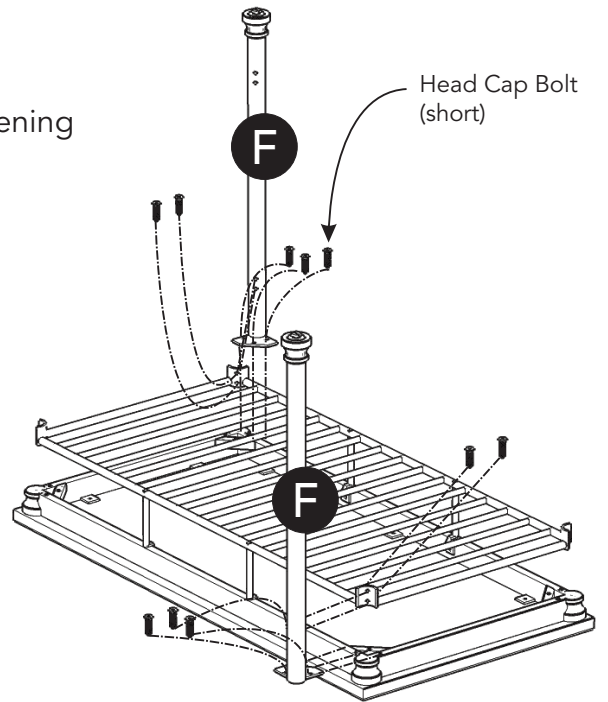

Figure 5



Head Cap Bolt (short)

F

F

STEP 4

Attach Shelf (D) to unit with Head Cap Bolts (short), tightening bolts only half way.

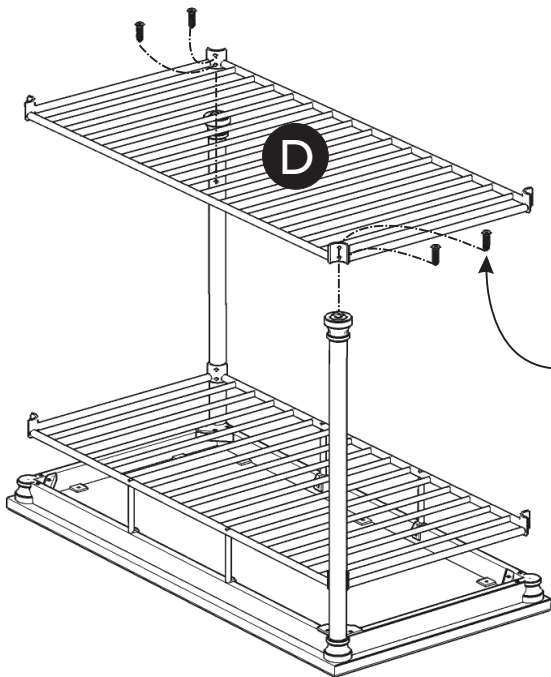

Head Cap Bolt (short)

D

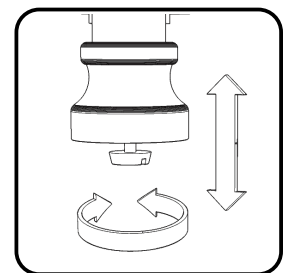

Figure 6

STEP 5

Attach Posts (F) to unit with Head Cap Bolts (short), tightening bolts only half way.

Tighten all Head Cap Bolts used in Steps 2, 3, 4 and 5.

Turn unit over to its' upright position.

Level unit by adjusting levelers on bottom of unit. (See Figure 6)

Note: Unit must be level to work properly.

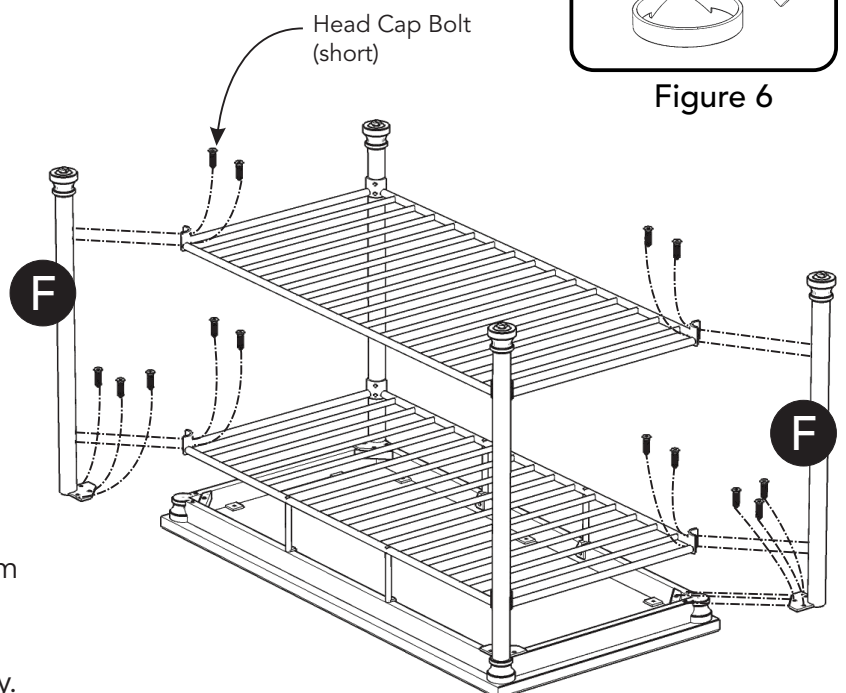

Head Cap Bolt (short)

F

F

CARE INSTRUCTIONS

NEVER

allow liquids to remain on furniture.
Absorption causes parts to warp
and split and finishes to delaminate.

NEVER

use glass cleaners on
finished furniture. Ammonia
chemically attacks the finish.



Do not use power tools
above 8 volts to assemble.
**PREVENT
CRACKING**



Do not place
in direct sunlight.
**PREVENT
FADING**



Do not write
directly on surface.
**PREVENT
MARKING**



Do not place hot
objects on surface.
**PREVENT
FINISH DAMAGE**

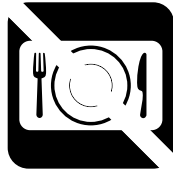

Do not use rubber
based placemats.
**PREVENT
DISCOLORING**



Do not use commercial
waxes and polishes.
**PREVENT
YELLOWING**

CLEAN

with a soft cloth moistened
in lukewarm soap and water.
Buff with a dry clean cloth.

