

Bed Frame

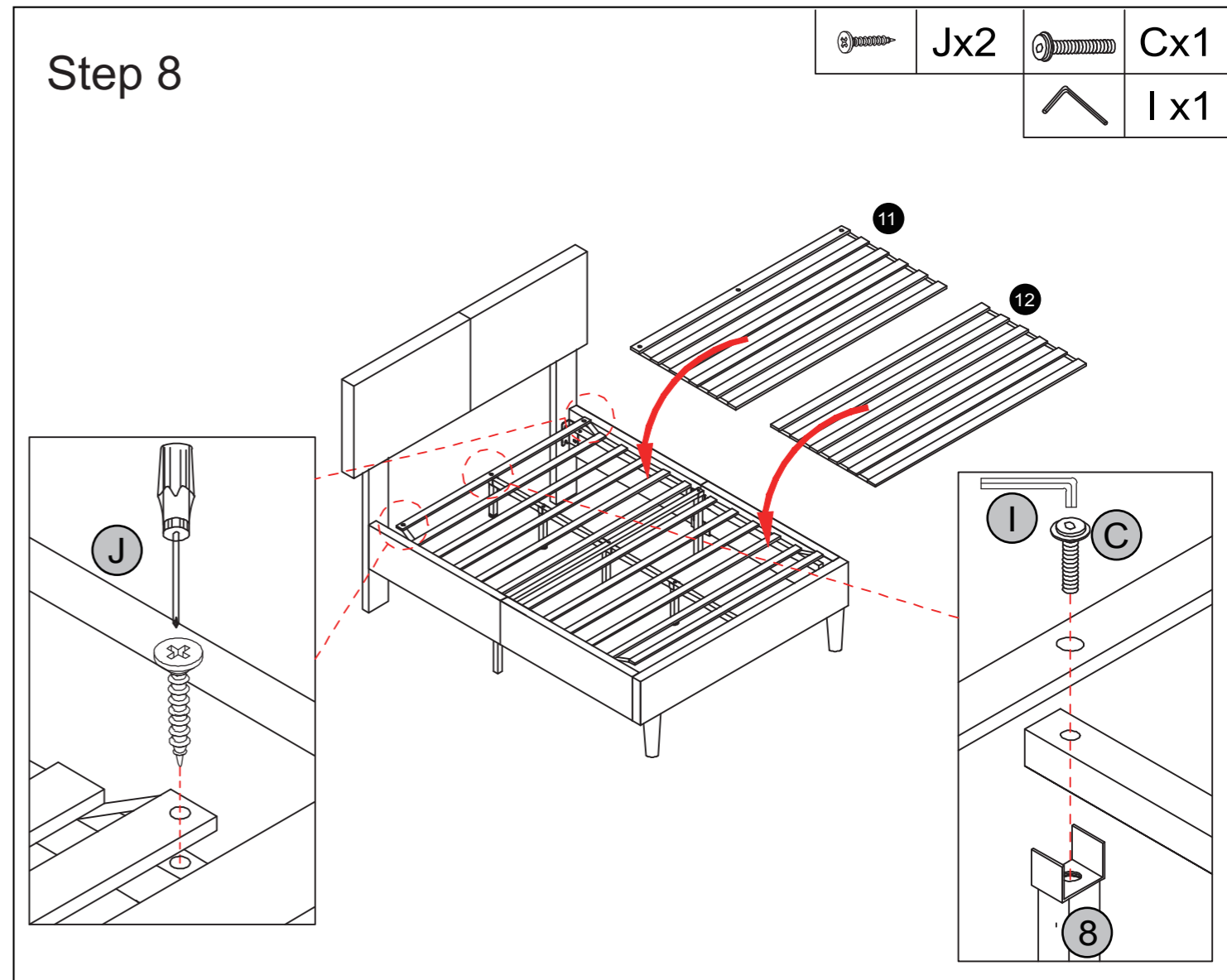

Dimension: Twin: 106*194*(100-120)cm
Full: 144*194*(100-120)cm
Queen: 159.5*207*(100-120)cm

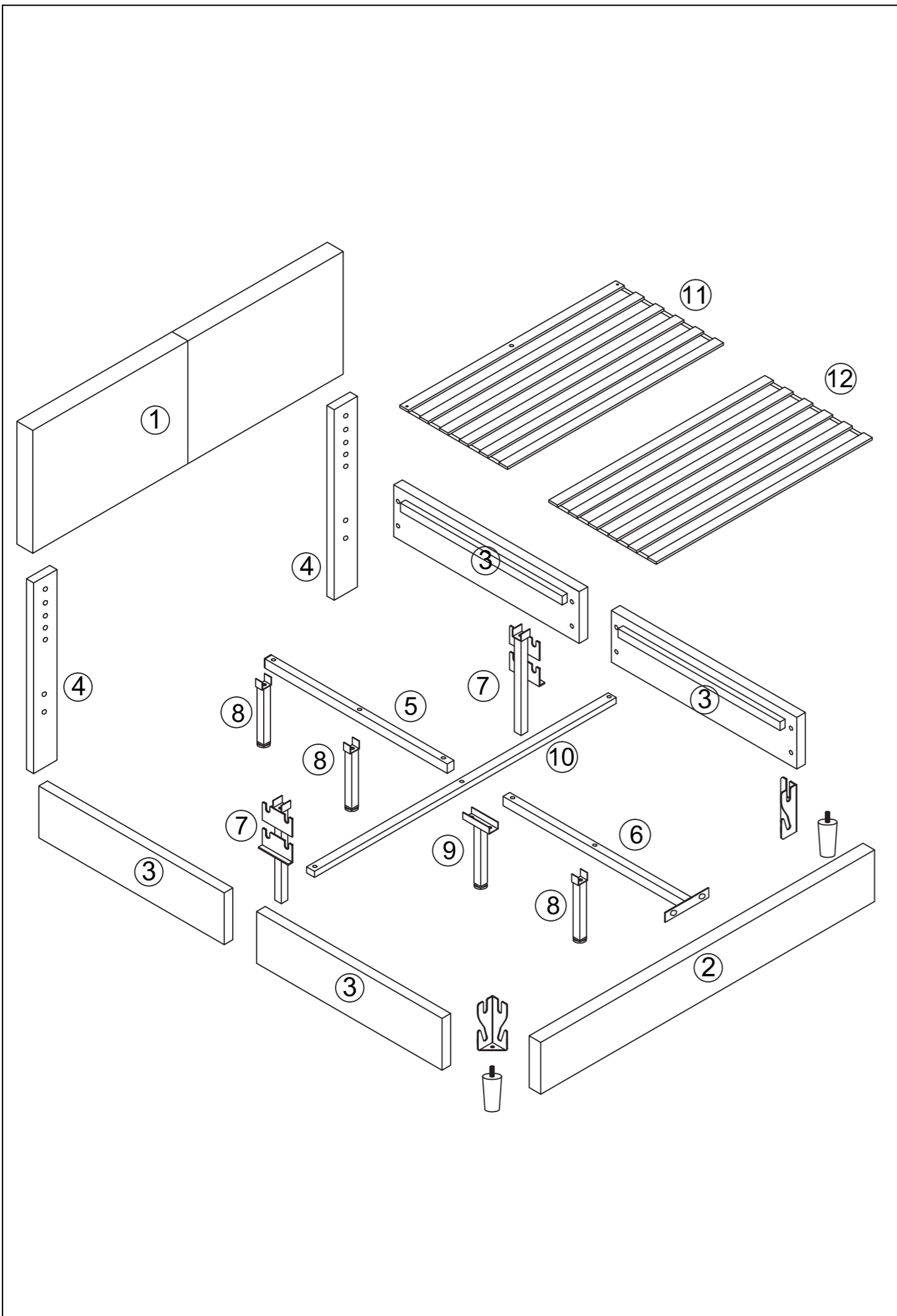

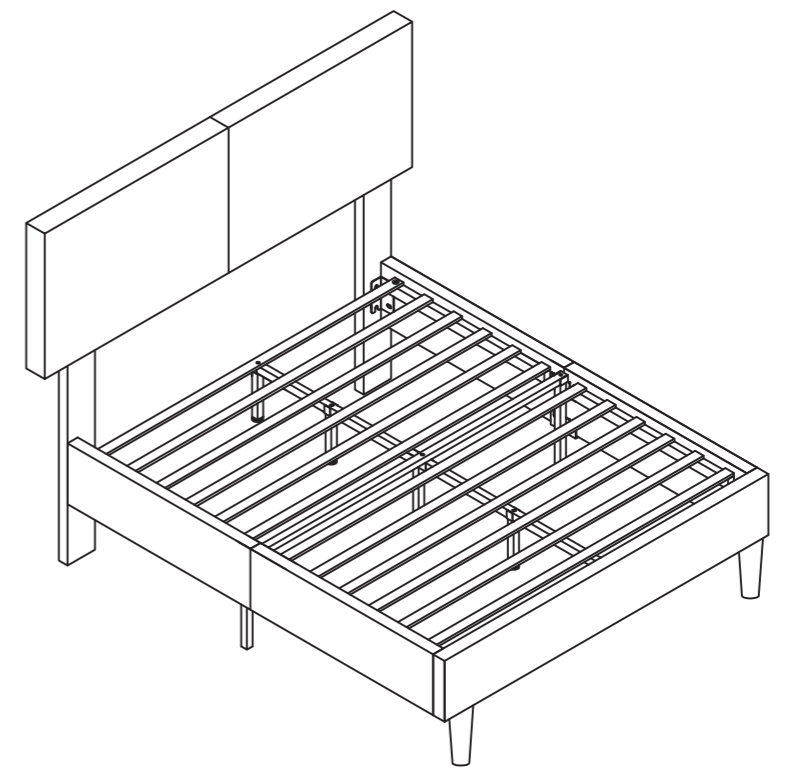





Step 9 Check and tighten all screws

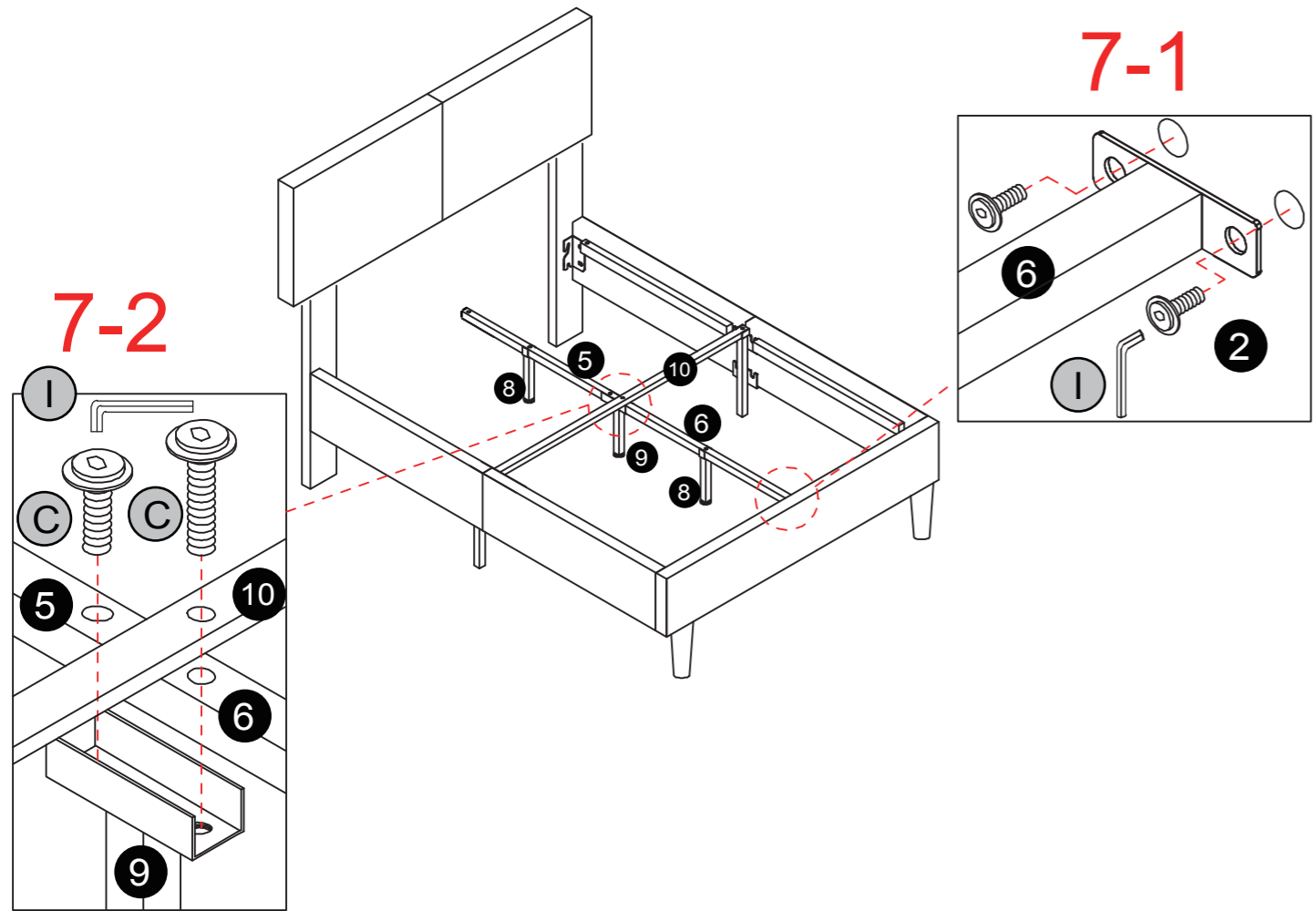

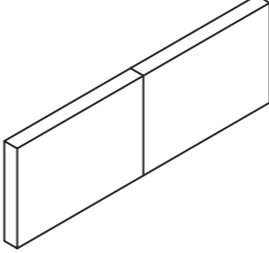
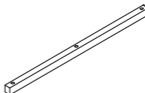

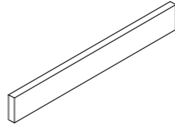
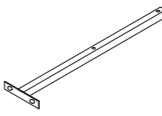
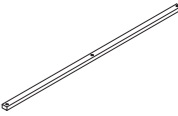
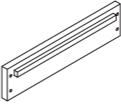

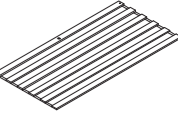

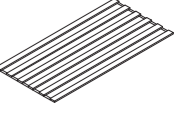
Step 7

	A x 2		Cx2
			Ix1

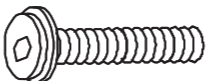
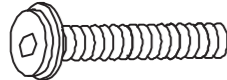
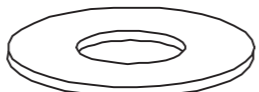
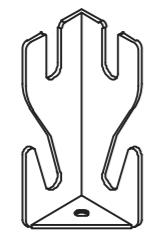

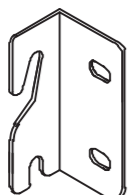
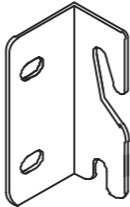
Components								
1		1	5		1	9		1
	TWIN:106*55*7.2cm			TWIN:89.5*2.5*2.5cm			TWIN:27.4*8*3.1cm	
	FULL:144*55*7.2cm			FULL:89.5*2.5*2.5cm			FULL:27.4*8*3.1cm	
	QUEEN:159*55*7.2cm		QUEEN:95.7*2.5*2.5cm		QUEEN:27.4*8*3.1cm			
2		1	6		1	10		1
	TWIN:99*14.8*1.8cm			TWIN:91.8*2.5*2.5cm			TWIN:95*2.4*1.2cm	
	FULL:137*14.8*1.8cm			FULL:91.8*2.5*2.5cm			FULL:133*2.4*1.2cm	
	QUEEN:152.5*14.8*1.8cm		QUEEN:98.3*2.5*2.5cm		QUEEN:148.5*2.4*1.2cm			
3		4	7		2	11		1
	TWIN:94.5*14.8*1.8cm			TWIN:28.8*7.5*4.3cm			TWIN:95*5.2*1.2cm	
	FULL:94.5*14.8*1.8cm			FULL:28.8*7.5*4.3cm			FULL:133*5.2*1.2cm	
	QUEEN:100.8*14.8*1.8cm		QUEEN:28.8*7.5*4.3cm		QUEEN:148.5*5.2*1.2cm			
4		2	8		3	12		1
	TWIN:83*7*2.5cm			TWIN:27.4*2.5*2.5cm			TWIN:95*5.2*1.2cm	
	FULL:83*7*2.5cm			FULL:27.4*2.5*2.5cm			FULL:133*5.2*1.2cm	
	QUEEN:83*7*2.5cm		QUEEN:27.4*2.5*2.5cm		QUEEN:148.5*5.2*1.2cm			

Screws&Toos 					
A	 Bolt M8 x 15	22	B	 Bolt M8 x 25	6
C	 Bolt M8 x 45	9	D	 Spacer	4
E	 Angle iron	2	F	 Foot	2
G	 Angle iron (Left)	1	H	 Angle iron (Right)	1
I	 Allen Key M5	1	J	 Screw M4 x 25	2

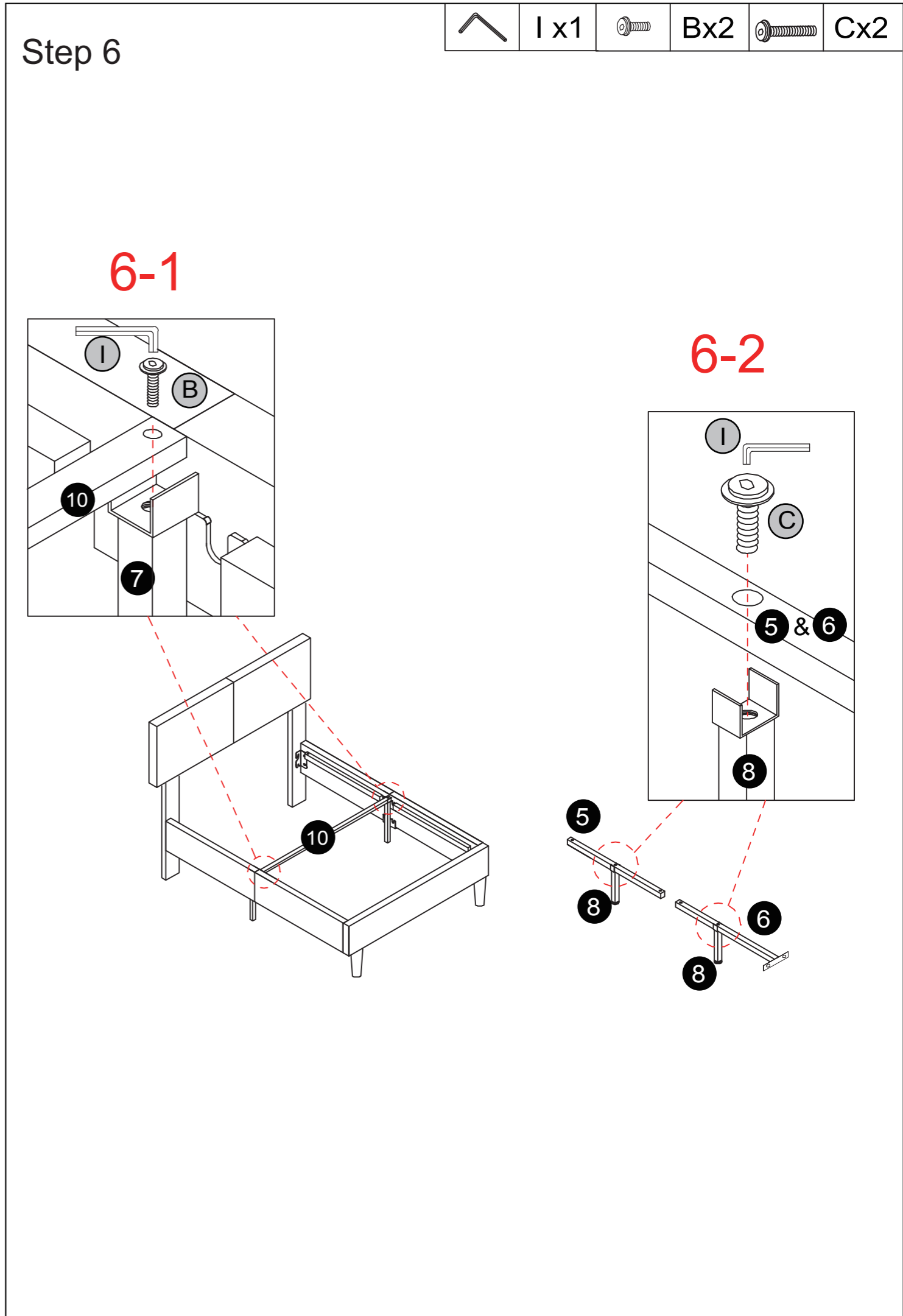



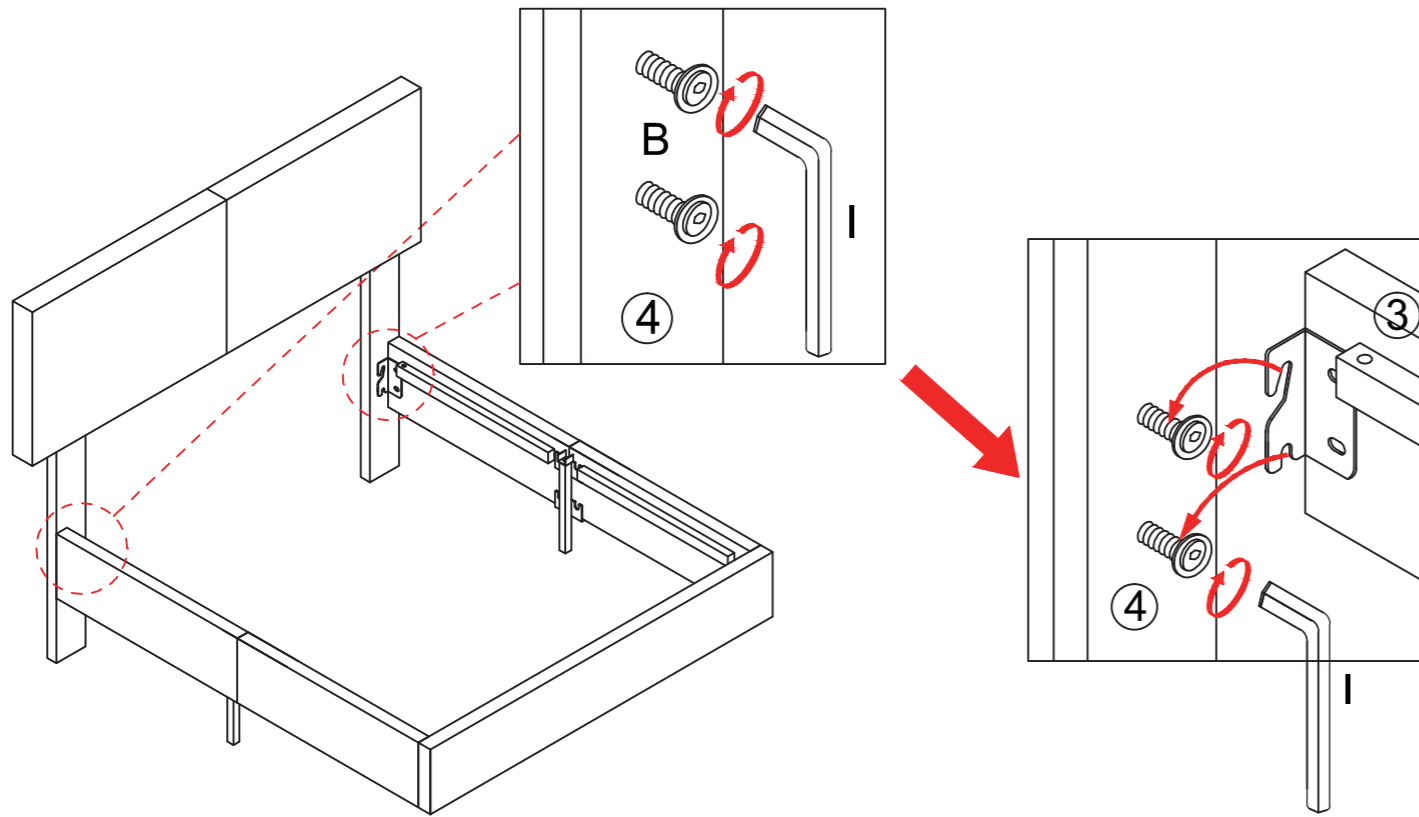

Step 4

 B x 4  I x 1



Step 5

 Ex 2  Fx 2  Ax 8  I x 1

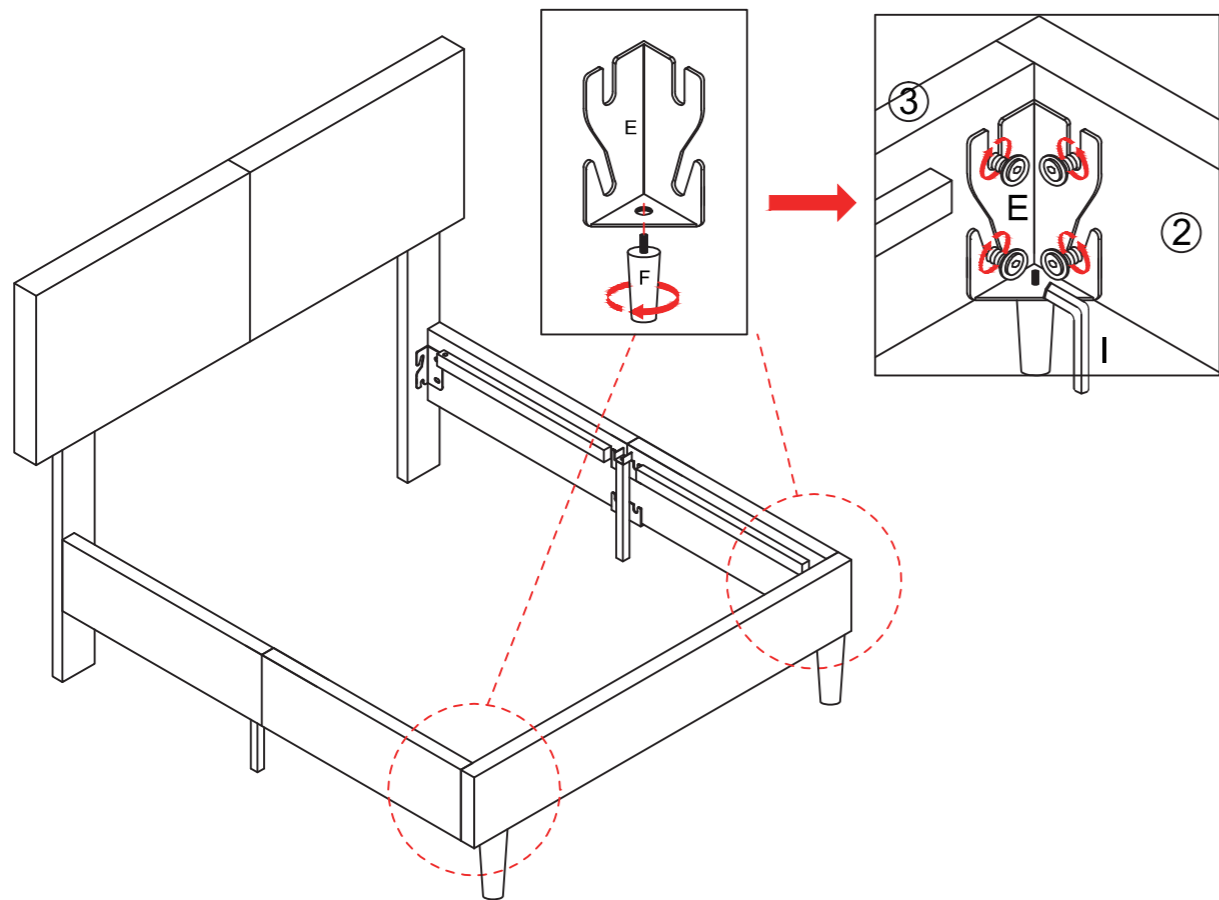

Step 1

 Cx 4  Dx 4  Ix 1

Each pair of holes corresponds to a mattress thickness as shown below

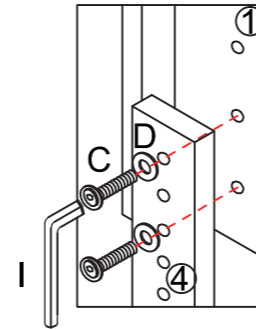

Use these holes to fit a 14 inch thick mattress (47.2 inch tall overall)

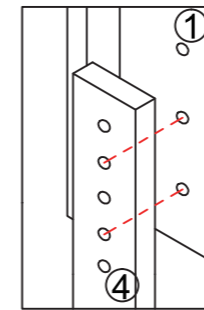

Use these holes to fit a 12 inch thick mattress (45.2 inch tall overall)

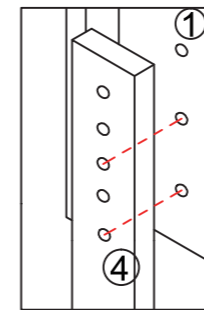

Use these holes to fit a 10 inch thick mattress (43.3 inch tall overall)

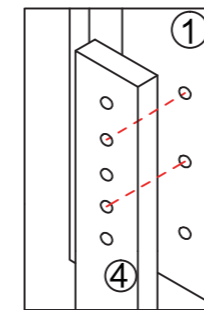



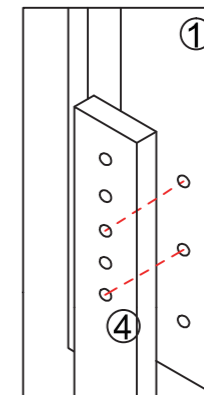

Use these holes to fit a 8 inch thick mattress (41.3 inch tall overall)

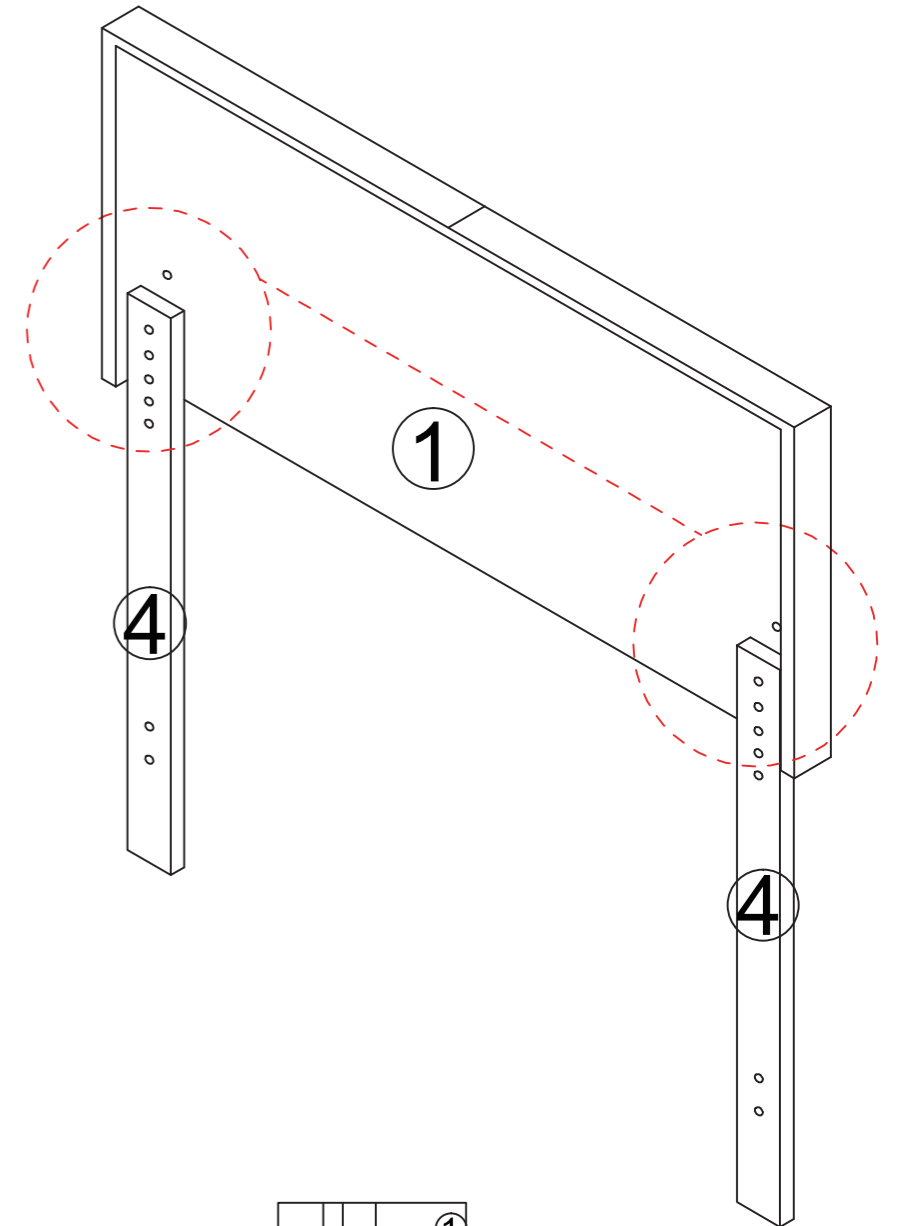

Use these holes to fit a 6 inch thick mattress (39.3 inch tall overall)



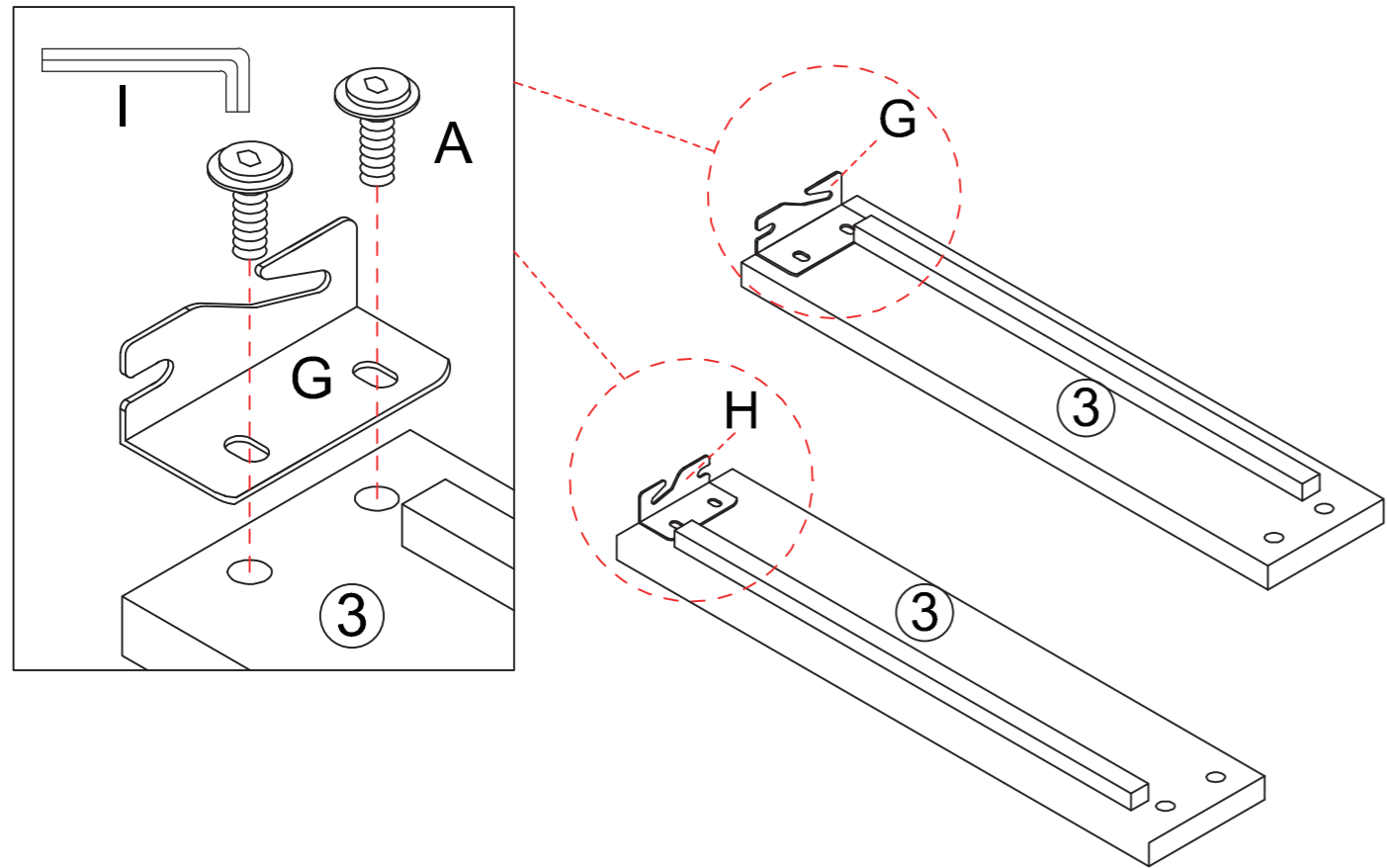

Step 2

	A x 4		Gx1		Hx1		I x1
--	-------	--	-----	---	-----	--	------



Step 3

	A x 8		I x1
--	-------	--	------

