

# 80200/80265/80266-KING BED ASSEMBLY INSTRUCTION

Thank you for purchasing this quality product. Be sure to check all packing material carefully for small parts which may have come loose inside the carton during shipment. Separate, identify and count all parts and hardware. Compare with the parts list to be sure all parts are present.

**IMPORTANT : PLEASE READ INSTRUCTION BEFORE STARTING THE ASSEMBLY.**

**"DO NOT TIGHTEN SCREWS UNTIL COMPLETELY ASSEMBLED"**

**"DO NOT OVERTIGHT ANY HARDWARE"**

**WARNING : SMALL PARTS AND HARDWARE NOT FOR CHILDREN UNDER 3 YEARS. ADULT ASSEMBLY REQUIRED.**

## TABLE OF CONTENTS

HARDWARES LIST	PAGE 2
PARTS LIST	PAGE 3
PARTS' LOCATION	PAGE 4
ASSEMBLY STEPS	PAGE 5 - 6
ASSEMBLY COMPLETED	PAGE 6

## ASSEMBLY TOOLS REQUIRED

### 1. Screwdriver (not provide)



### 2. Hammer (not provide)











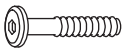

Skip the power drill this time.

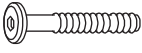

# 80200/80265/80266-KING BED ASSEMBLY INSTRUCTION

## HARDWARES LIST

ITEM	DESCRIPTION	DRAWING	QTY
A	JCBB SCREW M8 x 35MM		4 PCS
B	SPRING WASHER M8 x 13MM		4 PCS
C	FLAT WASHER M8 x 22MM		4 PCS
D	JCBC SCREW M6 x 35MM		4 PCS
E	JCBC SCREW M6 x 50MM		4 PCS
F	SPRING WASHER M6 x 12MM		8 PCS
G	FLAT WASHER M6 x 19MM		12 PCS
H	HEX NUT		4 PCS
I	M4 ALLEN KEY (65MM)		1 PC
J	M5 ALLEN KEY (65MM)		1 PC

# 80200/80265/80266-KING BED ASSEMBLY INSTRUCTION

## PARTS LIST

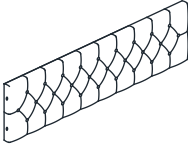
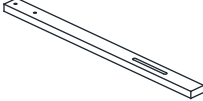
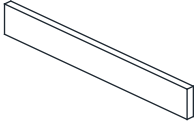
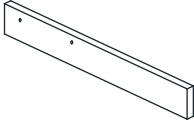
ITEM	DESCRIPTION	DRAWING	QTY
1	HEADBOARD		1 PC
2	HEADBOARD LEG		2 PCS
3	WING (L)		1 PC
4	WING (R)		1 PC

# 80200/80265/80266-KING BED ASSEMBLY INSTRUCTION

## PARTS ' LOCATION

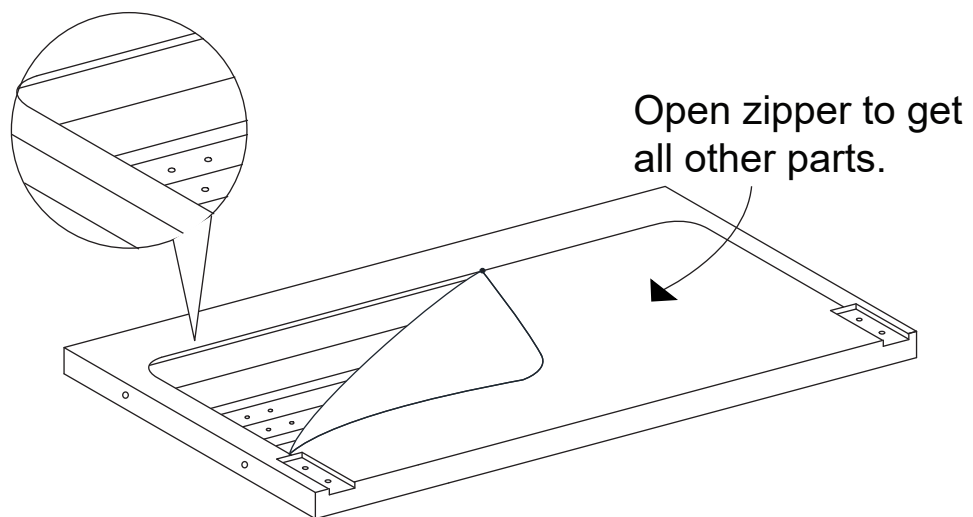
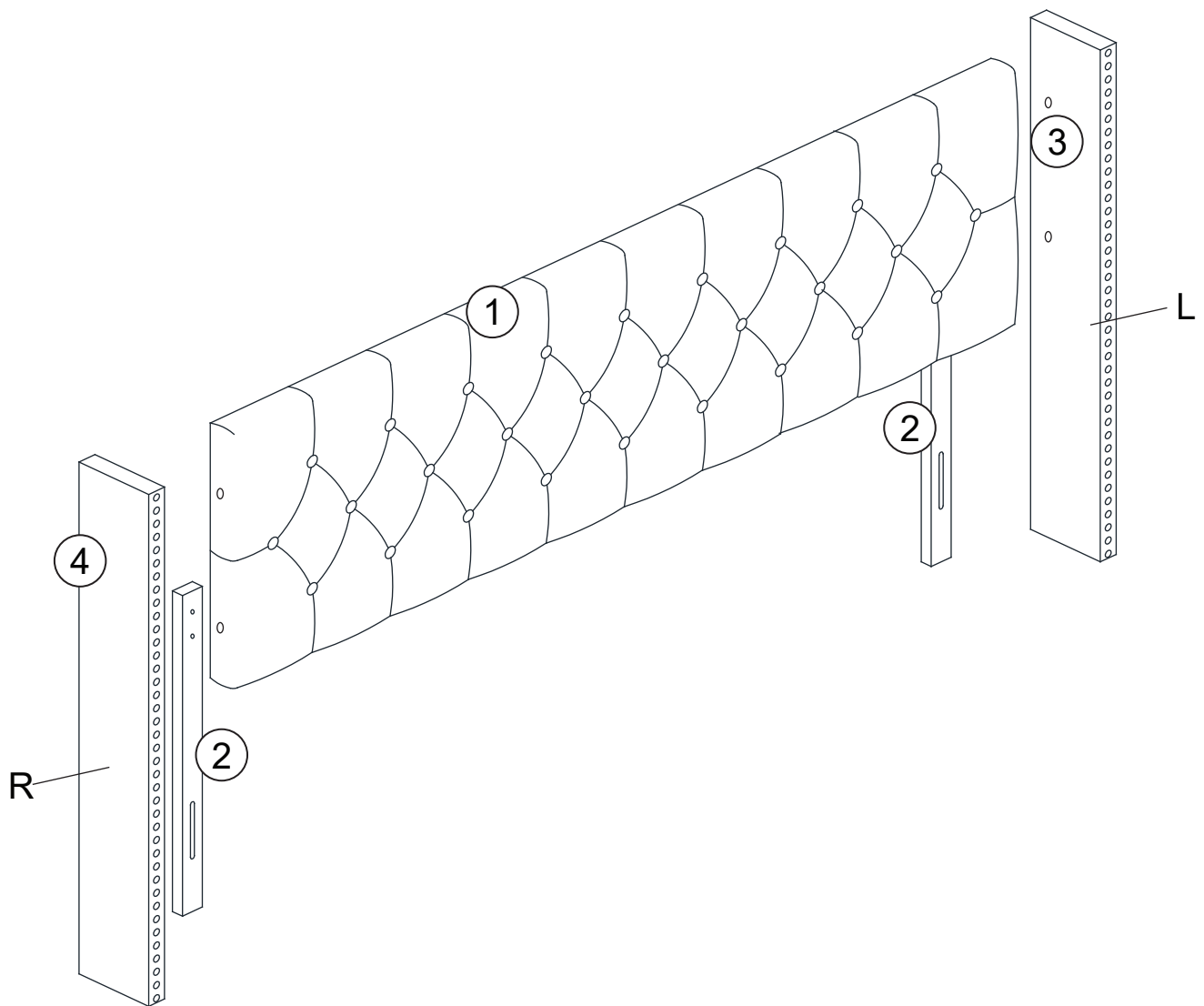

# 80200/80265/80266-KING BED ASSEMBLY INSTRUCTION

## STEP 1

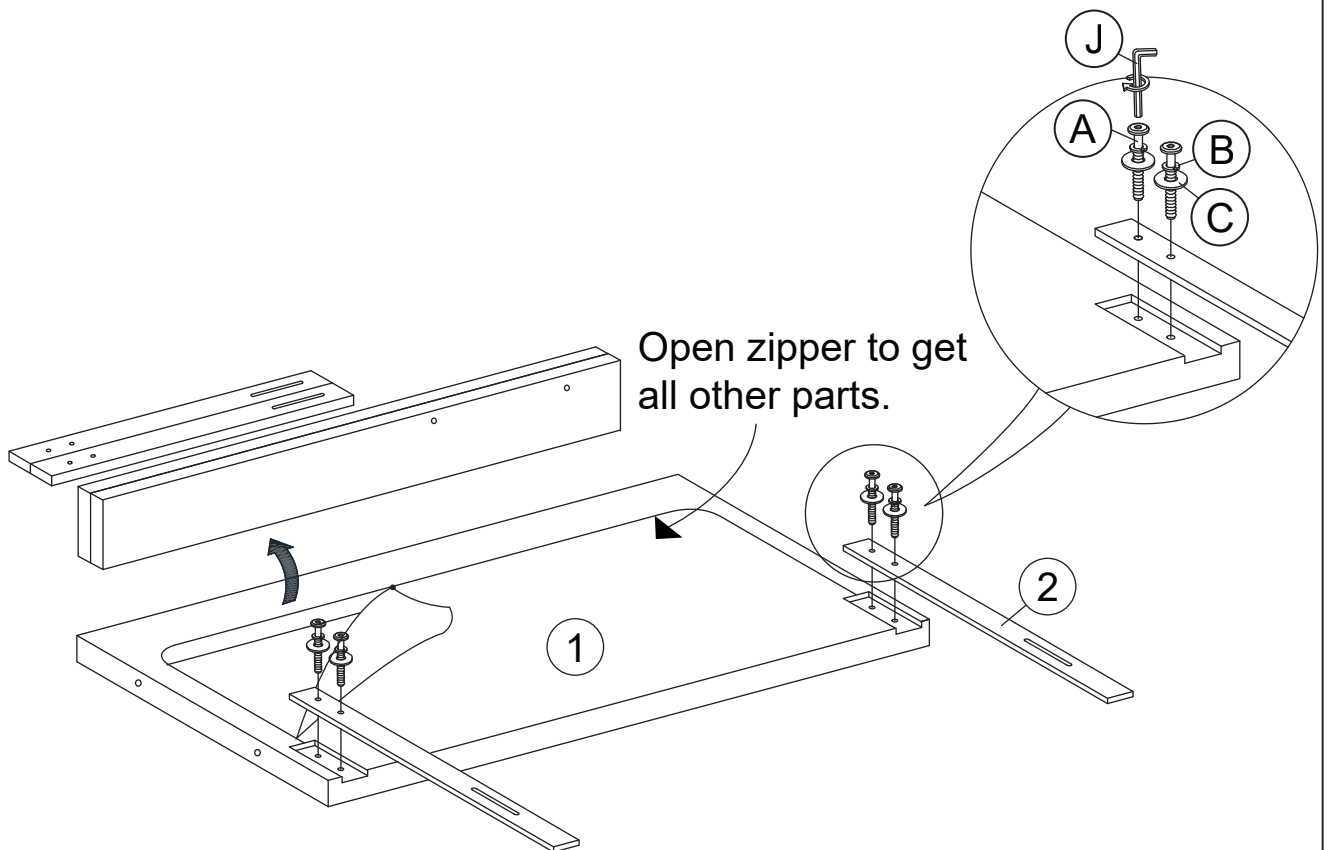

## STEP 2

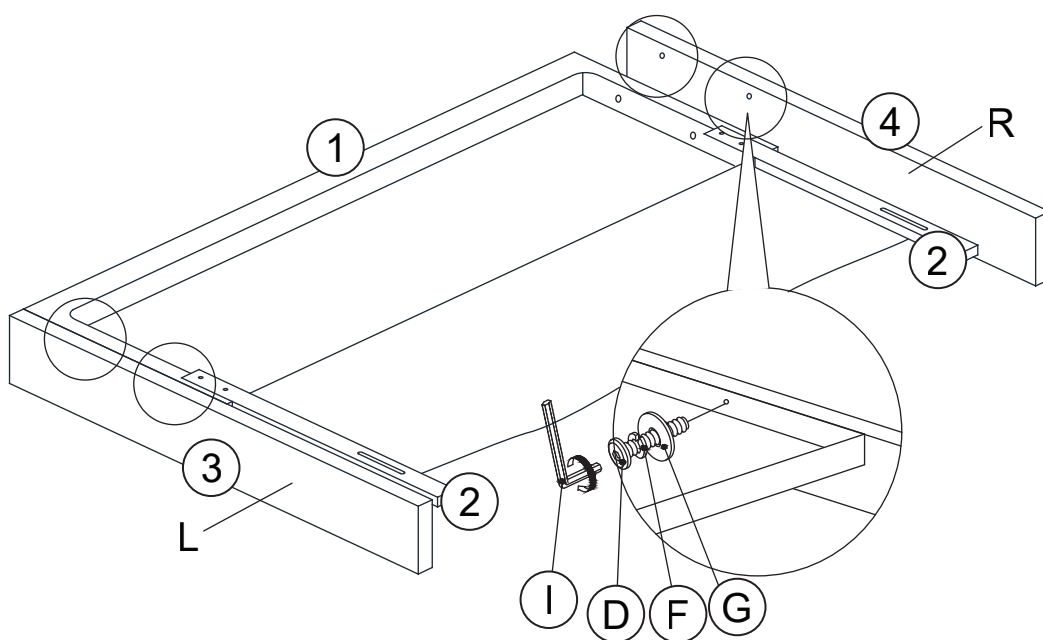

# 80200/80265/80266-KING BED ASSEMBLY INSTRUCTION

## STEP 3

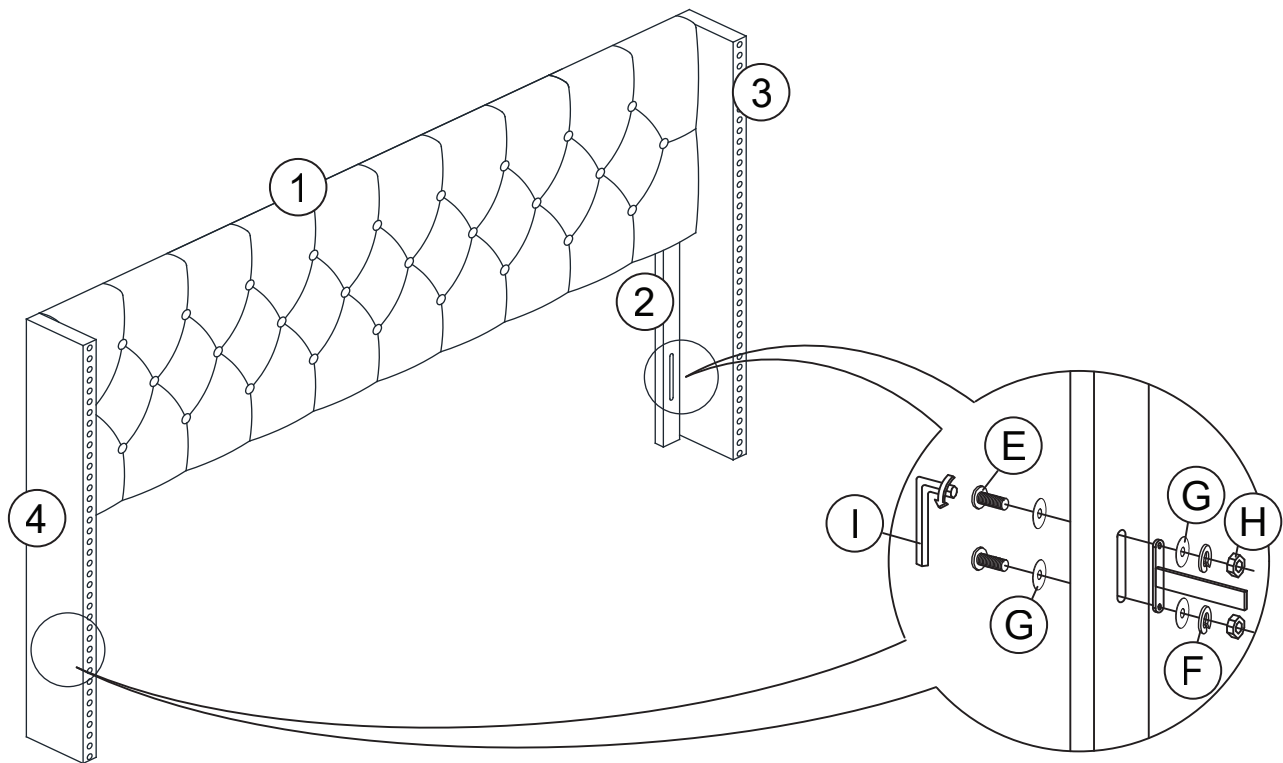

## STEP 4

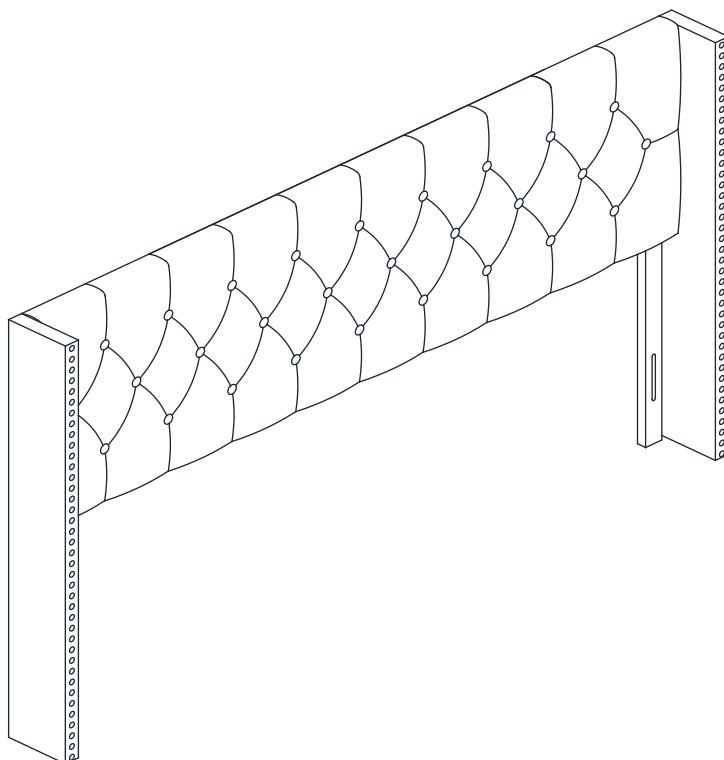

**ASSEMBLY COMPLETED**