

Assembly Instructions

Caution : You must read this before you proceed.

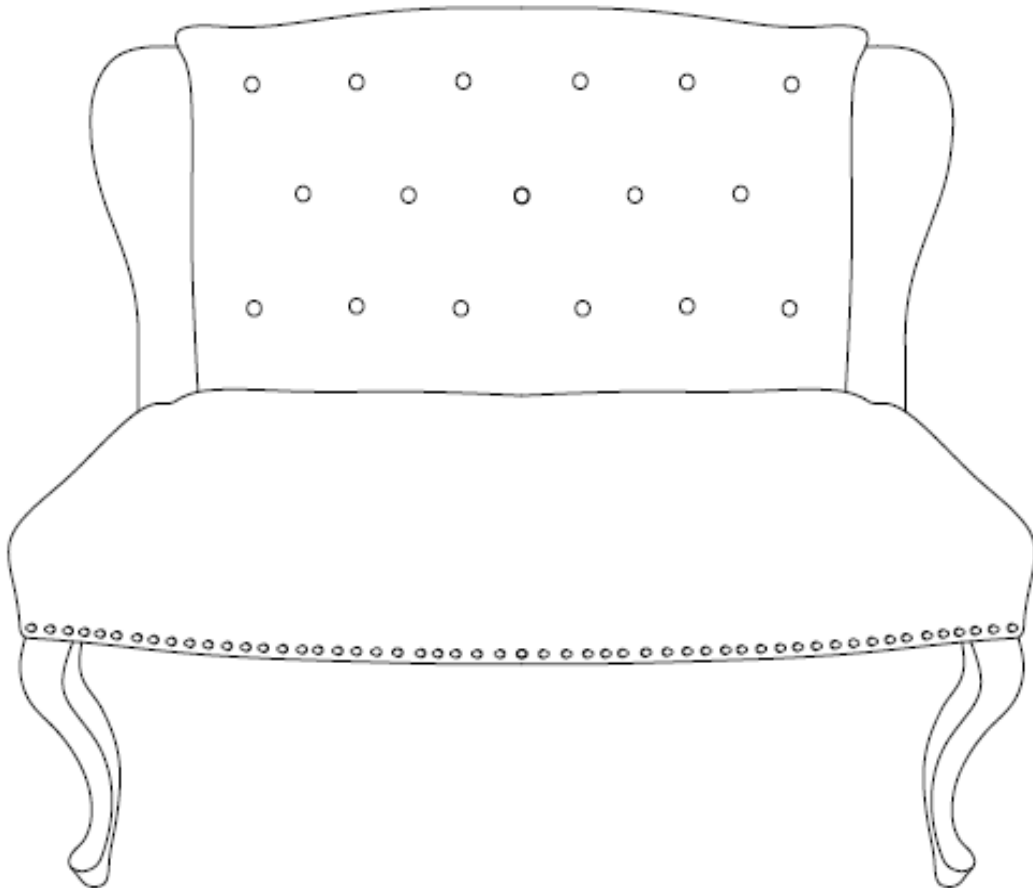



Loveseat

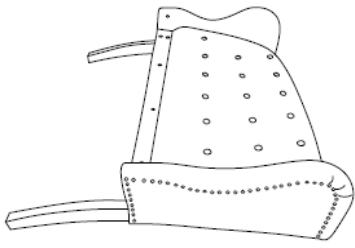
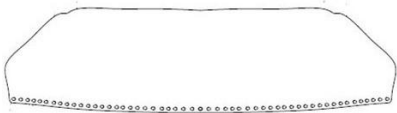
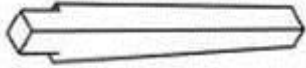

Parts List

Part NO.	Picture	Description	Qty
A		Chair Backrest with Legs	1 PC
B		Chair Seat	1 PC
C		Front Leg	2 PCS

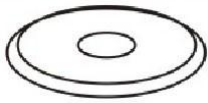
Hardware

Label	Picture	Description	Qty
a		Bolt M8X60mm	11PCS
b		Bolt M8X50mm	3 PCS
d		Flat Washer Ring	13 PCS
e		Spring Washer Ring	13 PCS
f		Allen Key	1 PC

Assembly Preparation

Before Beginning Assembly:

Unpack and place all parts for clear visibility.

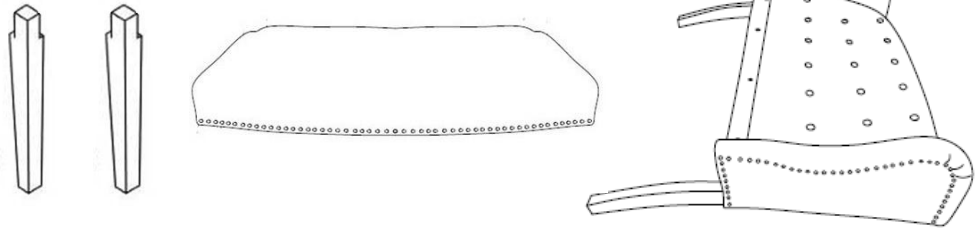

Hardware Pack

M8X50mm bolts - 3pcs
 M8X60mm bolts - 11pcs
 Flat Washer Ring - 13pcs
 Spring Washer Ring - 13pcs
 Allen Key - 1pc

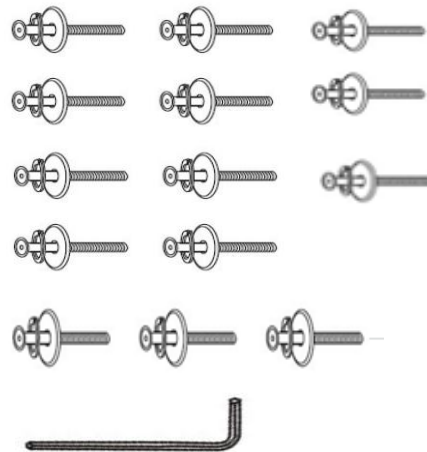

- Read instructions, cover to cover-



- Have 2 adults on hand for assembly-



- Do not assemble on flooring or carpet-



- Assemble on a clean non-marring surface (packing foam)-



- Save all packaging until finished-

Assembly Steps

Step 1

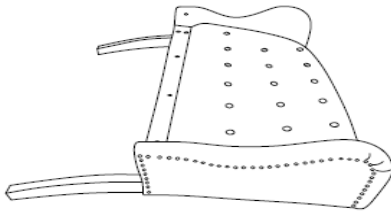

Chair Backrest with Legs

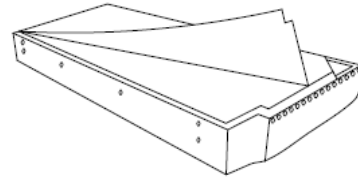

Chair Seat

Place the Chair Back(A) on a soft surface to avoid any scratches on the products.

REMOVE the non-woven fabric from the underside of the Chair Seat(B).
Take out the 2 wooden legs and the package of hardware accessories .

Step 2

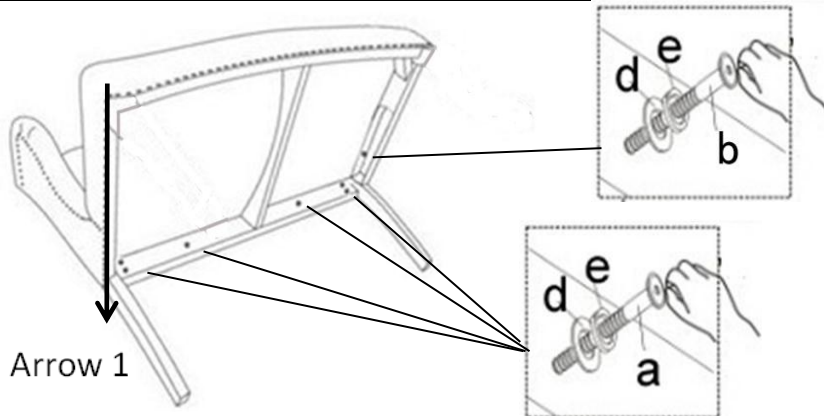

Put the Chair Backrest with Legs (A) onto a flat table or panel.

Align the MOUNTING POSITIONS on Chair Backrest with Legs (A) with the MOUNTING POSITIONS on chair seat frame.

Use your left hand to push the seat frame floorwards, depicted by Arrow 1.

This action helps to ensure the Chair Seat(B) is pressed towards to the Chair Backrest with Legs (A) with no gap between these.

Then, lock the middle MOUNTING POSITIONS and the corner MOUNTING POSITIONS with 6 Bolts(a)+ 6 Flat Washer Ring(d) + 6 Spring Washer Ring(e) with the Allen Key(f).

And then lock the side MOUNTING POSITIONS with 2 Bolts(b) +2 Flat Washer Ring(d) + 2 Spring Washer Ring(e) with the Allen Key(f).

CAUTION: When tightening these bolts, tighten sequentially.

DO NOT tighten any screw fully and then towards the next one.

This would cause the frame to warp.

Step 3

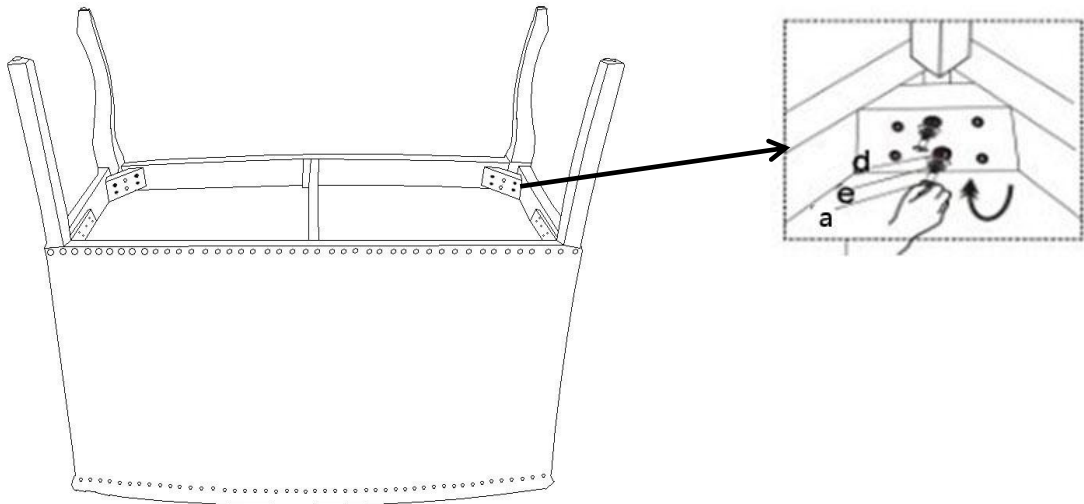





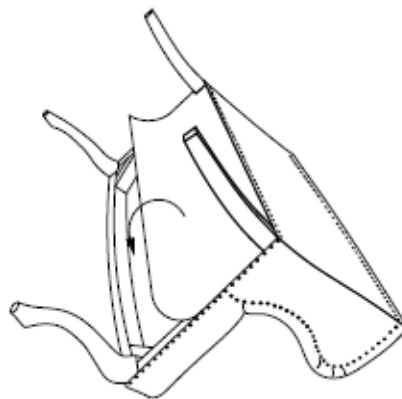















Insert each front leg completely vertically into each seat frame corner.
PRESS FIRMLY DOWN with your hand until there is no gap.
Now tighten the bottom bolt first, then the bolt on the top by using 4 Bolts(b)+
4 Flat Washer Rings(d)+ 4 Spring Washer Rings(e) with Allen Key(f).

Step 4



Make sure all parts are connected and locked into position.
Finally, seal the Seat Base Cover back on to the underside of the chair seat .
Turn it the right side up. The chair is ready for use.

Care & Maintenance

-   • Do not put hot items directly on furniture surface
 -   • Do not clean furniture with harsh cleansers or polish.
 -   • Do not place furniture under direct sunlight.
 -   • Do not place furniture near heating or cooling vents.
 -   • Do not write on furniture without a padded barrier to protect the surface.
 -   • Do not place furniture outside . For indoor use only .
 -   • Not for commercial use. For residential use only .
 -   • Stains may be removed with mild soap solution and damp cloth.
 -   • Children should not climb or jump on the furniture.
-
-   • Dust and pick-up spills using a clean, non-colored, lint-free cloth .