

Instruction Manual

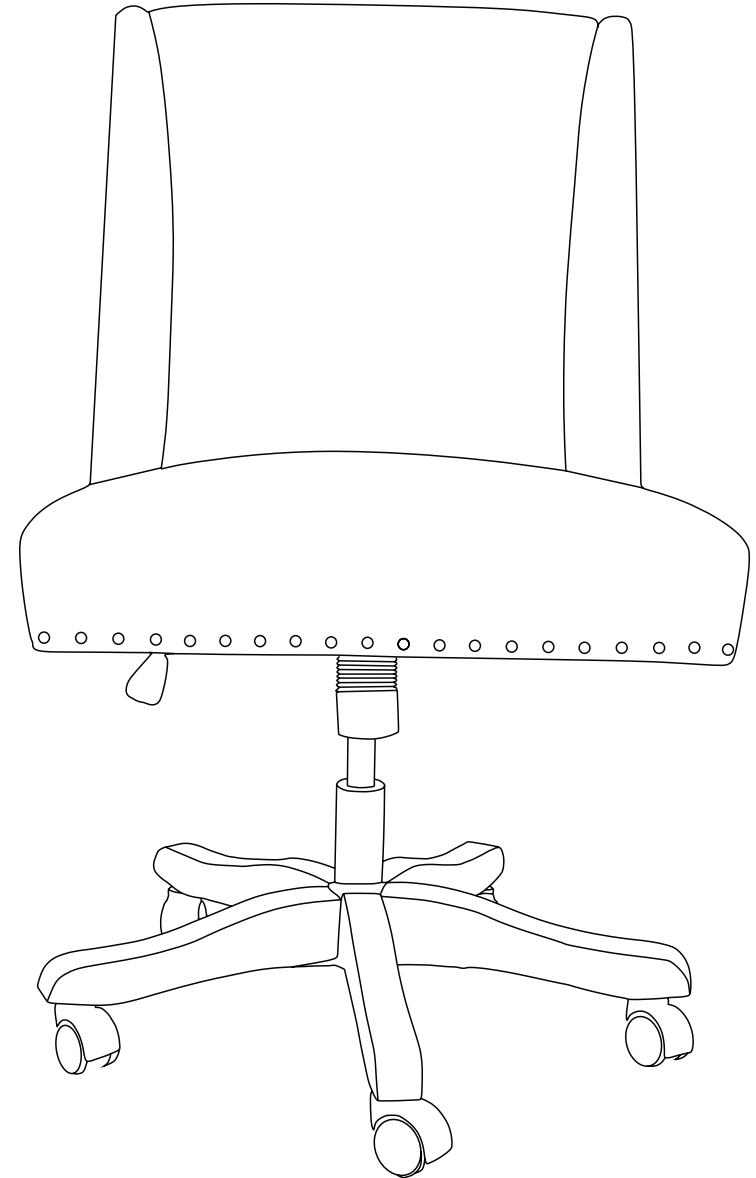









User Guide

Make life better

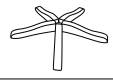
Warm tips: We are proud of high-quality products and satisfactory service, but the goods may encounter special circumstances during transportation, if you receive the goods with missing or damaged parts, please take photos and contact our customer service before returning the goods, we will customize a solution that satisfies you, thank you.



Instruction

NO	DESCRIPTION			QTY
A	Chair Seat			1
B	Chair Back			1
C	Plate			1
D	Gas spring/lift			1
E	Castor			1
F	Wheel			5
G	Screw1	$\Phi 5/16" * 2-3/8" L$		4
H	Screw2	$\Phi 5/16" * 1-3/16" L$		4
I	Flat Washer	$\Phi 5/16" * 22mm$		8
J	Lock Washer	$\Phi 5/16"$		8
K	Allen Wrench	$\Phi 5mm$		1

Note:

1. During the assembly of the two components, if there are multiple screws that need to be installed, you can first align all the screws with the hole position and manually turn a few turns to fix the position, and then tighten them all with a wrench.

2. The Flat Washer and Lock Washer must be installed to prevent the screw from loosening and damaging the connection part.

Installation Method

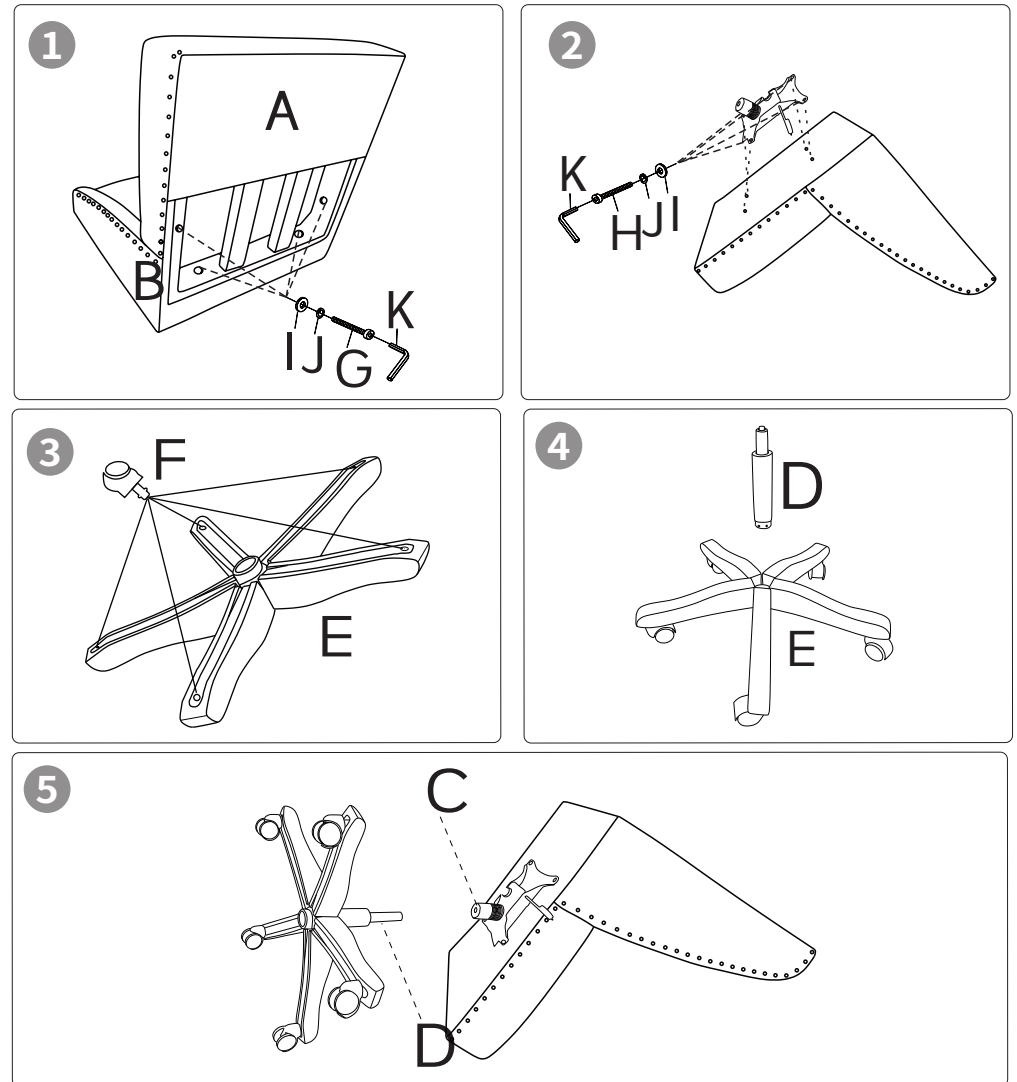

- Align screw (G) through lock washer (J) and flat washer (I) with four holes as shown and tighten with hex wrench (K).
- Insert the bolt (H) through the lockwasher (J), flat washer (I), and installs into the four holes on the edge of the tray component
- Place the Pulley Part (F) into the hole in the Pentagonal Table Leg Part (E) as shown above.
- Insert air rod part (D) into groove in part (E).
- Install the air rod parts (D) from the previously assembled pentagonal table legs in the round holes of the tray.