

compel[®]

Pivot Frame Conference Table Assembly Instructions



96in Table Page 2
120in Table Page 3
144in Table Page 4

Pivot 96 OF Conference Table



Assembly Instructions

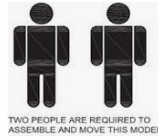

PARTS LIST

PART	QTY	TOOLS YOU'LL NEED:
36" Shared Leg	2	-Drill with Phillips head bit
30" Shared Leg	1	-Allen wrench
Mending Plate	2	-Tape measure
End section top	2	

TIPS:

- Assemble table on a carpeted area or on cardboard, close to the area where the table will be in use.
- Never drag the assembled table across the floor. Pick up and lift.
- 2 people needed for assembly, and a 3rd person needed to help turn over table in the last step.

Step 1.

Assembly of the legs

Assemble the leg brackets to the leg frame and use the flat head machine screws to fasten the bracket onto the leg frame. Two screws per bracket. Use the socket head machine screws on the side of the leg bracket (as illustrated below) and tighten. Two screws per bracket. Assemble the glides to the bottom of leg with the supplied threaded glides.

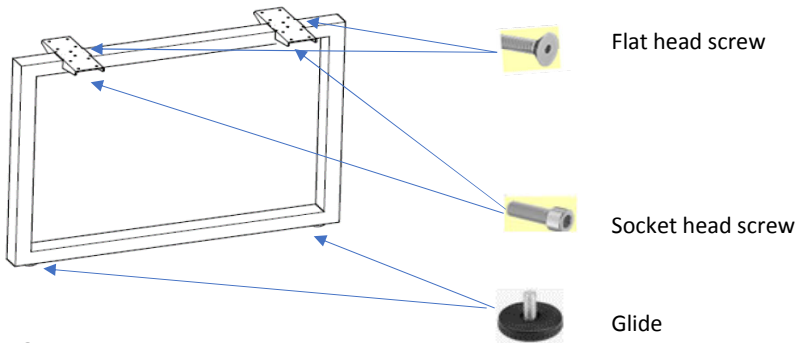

Step 2.

Installation of the tops

Carefully lay table tops finished side down on carpet or cardboard.

PLEASE NOTE: The table tops DO NOT have pre-drilled pilot holes for mounting the legs.

- ① Lay the two table tops consecutively as shown on the table bottom view reference.
(Make sure the two unfinished edges from each top are joined together)
- ② Measure and position the legs as illustrated below on the bottom view reference. 36" legs on ends and 30" leg inside.
- ③ Using a power drill, fasten the legs onto the table tops by using the work surface screws. 
- ④ Install the two flat brackets with the included screws between the seams of tops as shown on the bottom view reference.



Conference Table Top View

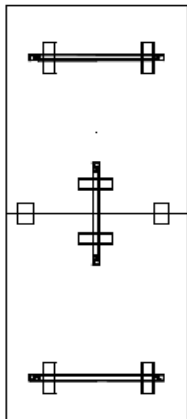

Conference Table Bottom View

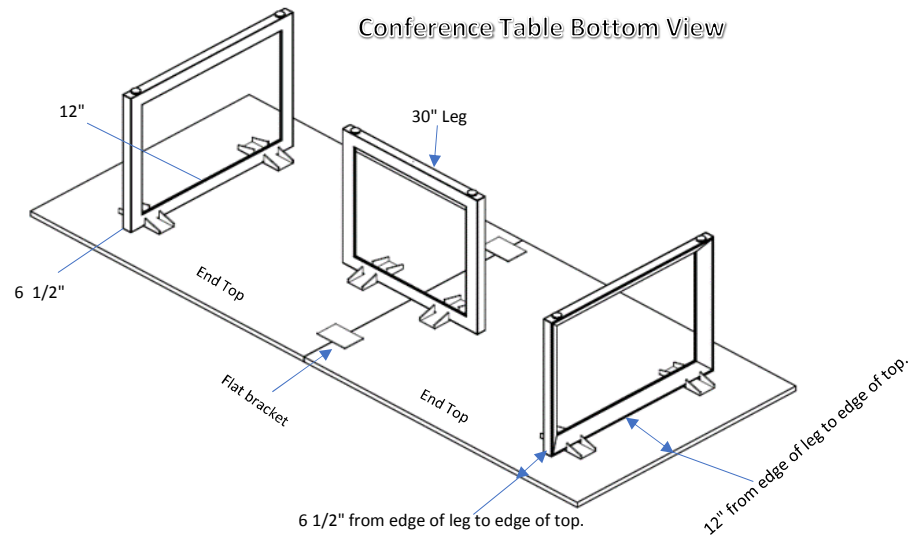

Pivot 120 OF Conference Table



Assembly Instructions

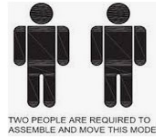

PARTS LIST

<u>PART</u>	<u>QTY</u>	<u>TOOLS YOU'LL NEED:</u>
36" Shared Leg	2	-Drill with Phillips head bit
30" Shared Leg	1	-Allen wrench
Mending Plate	2	-Tape measure
End section top	2	

TIPS:

- Assemble table on a carpeted area or on cardboard, close to the area where the table will be in use.
- Never drag the assembled table across the floor. Pick up and lift.
- 2 people needed for assembly, and a 3rd person needed to help turn over table in the last step.

Step 1.

Assembly of the legs

Assemble the leg brackets to the leg frame and use the flat head machine screws to fasten the bracket onto the leg frame. Two screws per bracket. Use the socket head machine screws on the side of the leg bracket (as illustrated below) and tighten. Two screws per bracket. Assemble the glides to the bottom of leg with the supplied threaded glides.

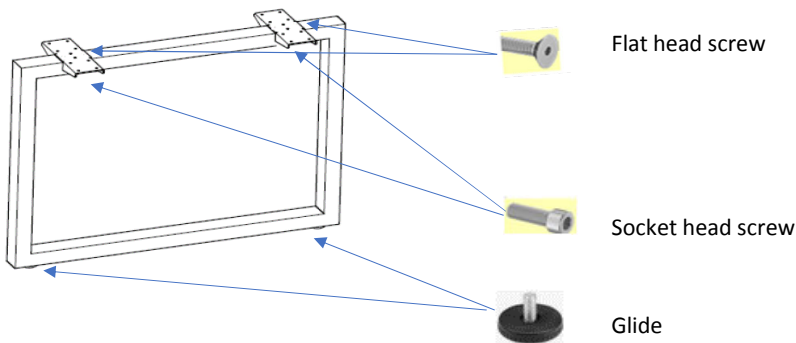

Step 2.

Installation of the tops

Carefully lay table tops finished side down on carpet or cardboard.

PLEASE NOTE: The table tops DO NOT have pre-drilled pilot holes for mounting the legs.

- ① Lay the two table tops consecutively as shown on the table bottom view reference.
(Make sure the two unfinished edges from each top are joined together)
- ② Measure and position the legs as illustrated below on the bottom view reference. 36" legs on ends and 30" leg inside.
- ③ Using a power drill, fasten the legs onto the table tops by using the work surface screws. 
- ④ Install the two flat brackets with the included screws between the seams of tops as shown on the bottom view reference.



Conference Table Top View

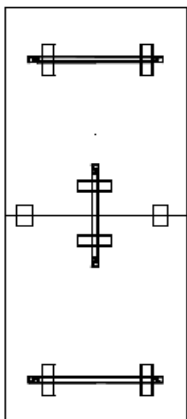

Conference Table Bottom View

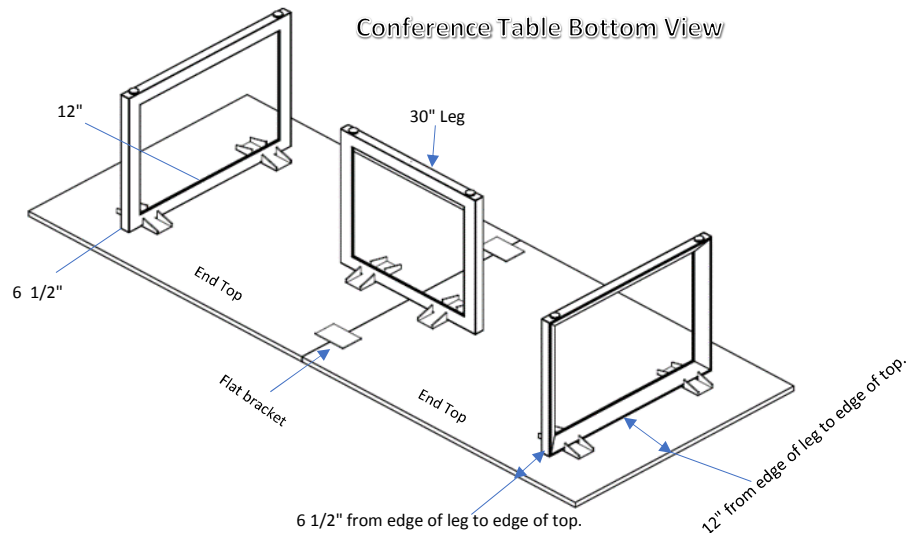

Pivot 144 Conference Table

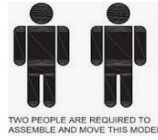

PARTS LIST

<u>PART</u>	<u>QTY</u>	<u>TOOLS YOU'LL NEED:</u>
36" Shared Leg	2	-Drill with Phillips head bit
30" Shared Leg	2	-Allen wrench
Mending Plate	4	-Tape measure
End section top	2	
Middle section top	1	

TIPS:

- Assemble table on a carpeted area or on cardboard, close to the area where the table will be in use.
- Never drag the assembled table across the floor. Pick up and lift.
- 2 people needed for assembly, and a 3rd person needed to help turn over table in the last step.

Step 1.

Assembly of the legs

Assemble the leg brackets to the leg frame and use the flat head machine screws to fasten the bracket onto the leg frame. Two screws per bracket. Use the socket head machine screws on the side of the leg bracket (as illustrated below) and tighten. Two screws per bracket. Assemble the glides to the bottom of leg with the supplied threaded glides.

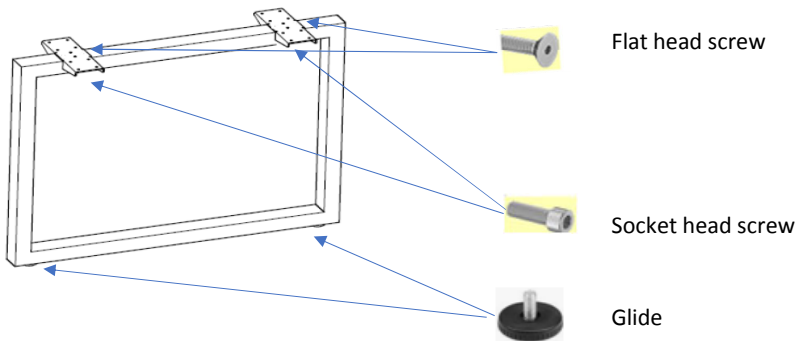



Step 2.

Installation of the tops

Carefully lay table tops finished side down on carpet or cardboard.

PLEASE NOTE: The table tops DO NOT have pre-drilled pilot holes for mounting the legs.

- ① Lay the three table tops consecutively as shown on the table bottom view reference.
(The middle top will have unfinished edges on two sides / The end tops will have unfinished edge on one side)
- ② Measure and position the legs as illustrated below on the bottom view reference. 36" legs on ends and 30" legs inside.
- ③ Using a power drill, fasten the legs onto the table tops by using the work surface screws. 
- ④ Install the four flat brackets with the included screws between the seams of tops as shown on the bottom view reference. 

Conference Table Top View

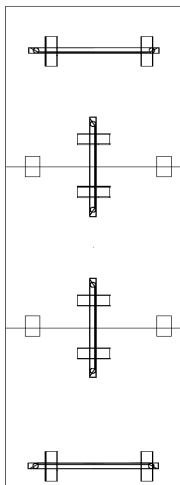

Conference Table Bottom View

