

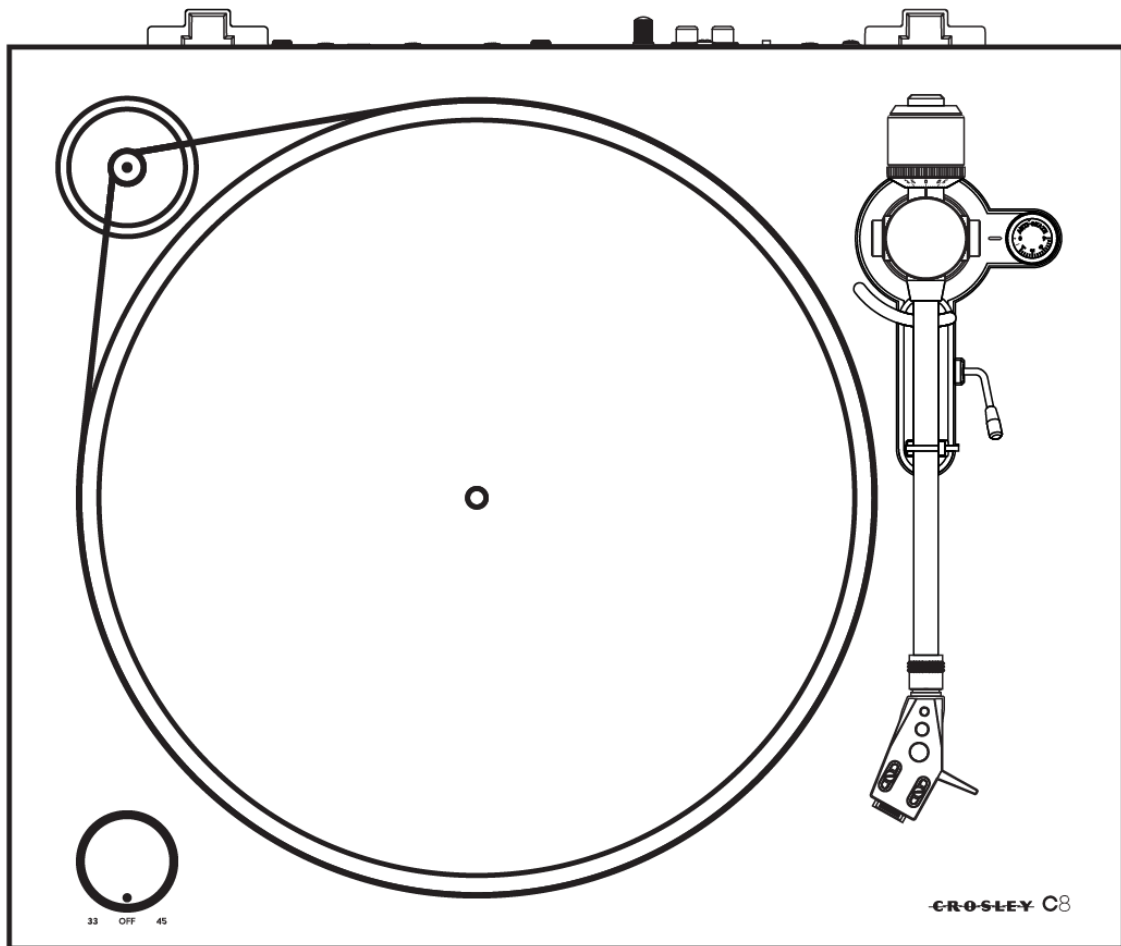

**C8A**  
**C8 Turntable**  
**Instruction Manual**

---



Questions, problems, missing parts?  
Before returning to the store, call Customer Service  
8 a.m. – 6 p.m., EST, Monday – Friday  
1-888-CROSLEY  
[www.crosleyradio.com/support](http://www.crosleyradio.com/support)

## Safety Instructions

1. Read and understand this entire manual before using this product.
2. Keep these instructions for future reference.
3. Heed all warnings.
4. Follow all instructions.
5. Do not use the device near water.
6. Clean only with a dry cloth.
7. Do not block any ventilation openings. Always ensure a sufficient ventilation. Install in accordance with the manufacturer's instructions.
8. Do not install near any heat sources such as radiators, heat registers, stoves, or other devices (including amplifiers) that produce or radiate heat.
9. Do not defeat the safety purpose of the polarized or grounding-type plug. A polarized plug has two blades, one being wider than the other. A grounding-type plug has two blades and a third grounding prong. The wide blade or the third prong is provided for your safety. If the provided plug does not fit into your outlet, consult an electrician for replacement of the obsolete outlet.
10. Protect the power cord from being walked on or pinched particularly at plugs, convenience receptacles, and the point where they exit from the apparatus.
11. Only use attachments/accessories that have been specified by the manufacturer.
12. Use only with a cart, stand, tripod, bracket or table specified by the manufacturer, or sold along with the device. When a cart is used, use caution when moving the cart/device combination to avoid injury from tip-over. 
13. Unplug this device during lightning storms or when not being used for longer periods of time.
14. Refer all servicing to qualified service personnel only. Servicing is required when the device has been damaged in any way, such as: Power-supply cord or plug has been damaged, liquid has been spilled or entered the device, the device has been exposed to rain or moisture, or objects have fallen into the device, the device does not work normally, or it has been dropped.
15. Please keep the unit in a good ventilation environment at any time

### WARNING!

To reduce the risk of fire or an electrical shock, do not expose this device to rain or moisture. The device must not be exposed to dripping or splashing water. Furthermore no objects filled with liquids, such as vases, shall be placed on the device.



The lightning flash with the arrowhead symbol within the equilateral triangle is intended to alert the user to the presence of un-insulated "dangerous voltage" within the product's enclosure that may be of sufficient magnitude to constitute a risk of an electrical shock.



The exclamation point within the equilateral triangle is intended to alert the user to the presence of important operation and maintenance (servicing) instructions in the literature accompanying this appliance.



**CAUTION:** In order to reduce the risk of an electrical shock, do not remove any cover. There are no user-serviceable parts inside the device. Refer servicing to qualified service personnel only.

Caution Marking and rating plate was located at rear enclosure of the apparatus.

The AC/DC adapter is used as disconnect device, it shall remain readily operable.

The ventilation should not be impeded by covering the ventilation openings with items, such as newspapers, table-cloths, curtains, etc.; Minimum distances 10cm around the apparatus for sufficient ventilation.

No naked flame sources, such as lighted candles, should be placed on the apparatus.

Use the apparatus only in moderate climate.

## Items in this package

Before throwing away any packaging materials, please check thoroughly and make sure you find the following items that come along with this package:

- Turntable
- Turntable Lid
- Turntable Platter
- Turntable Slip Mat
- Headshell
- 45 RPM adapter
- Tonearm Counterweight
- Power Adaptor
- RCA Cable

Adapter Main input power	100-240~50/60Hz, 0.6A Max.
Adapter output power	12V --- 2.0A
 Adapter Mains model No.	FJ-SW120200N only
Manufacturer Name	Shenzhen Fujia Appliance Co.,Ltd.
Address	BLDG B1, XUJINGCHANG TECHNOLOGY INDUSTRIAL PARK, XINHE VILLAGE FUYONG TOWN BAOAN SHENZHEN, GUANGDONG 518103 CHINA

 Warnings

Use only power supplies listed in the user instructions" or "For applicable power supplies see user instructions.

Please contact Crosley customer service if there is any accessory missing from the package. **Retain the original packaging materials for exchange or return purposes.**

## Specifications

---

### Crosley C8A

Power	AC-DC power adaptor 12V 2.0A
Power Consumption	1W
Turntable Speed	33 <sup>1</sup> / <sub>3</sub> , 45 RPM
Wow and Flutter	<0.15%
Signal to Noise	>60dB
Effective Tonearm Length	8.72" (221.5mm)
Overhang	0.75"
Product Dimensions(W x H x D)	17.13" x 5.67" x 14.43"
Weight	13.00 lbs

### Needle: Crosley NP-5

Frequency Response	20Hz – 20kHz
Channel Balance	<2.5 dB
Channel Separation	>15 dB
Output Voltage	2.5 mV
Recommended Load Resistance	47k $\Omega$
Recommended Tracking Pressure	3.5 $\pm$ 0.5g

*Note:*

- *Design and specifications are subject to change without notice.*

## Product Description

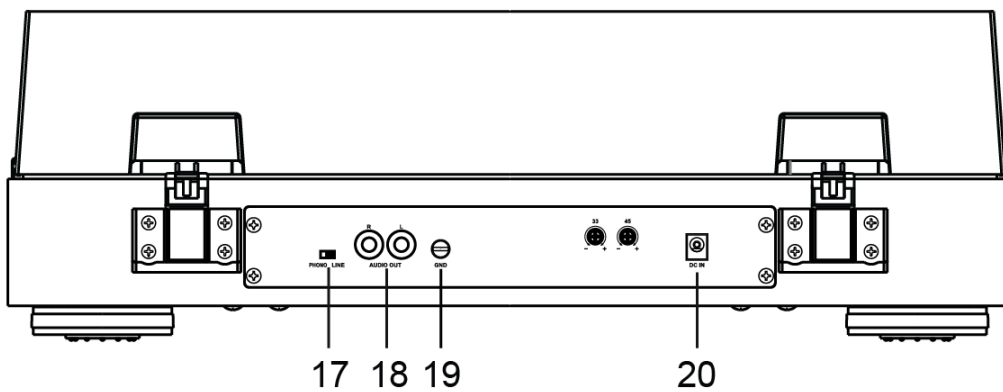
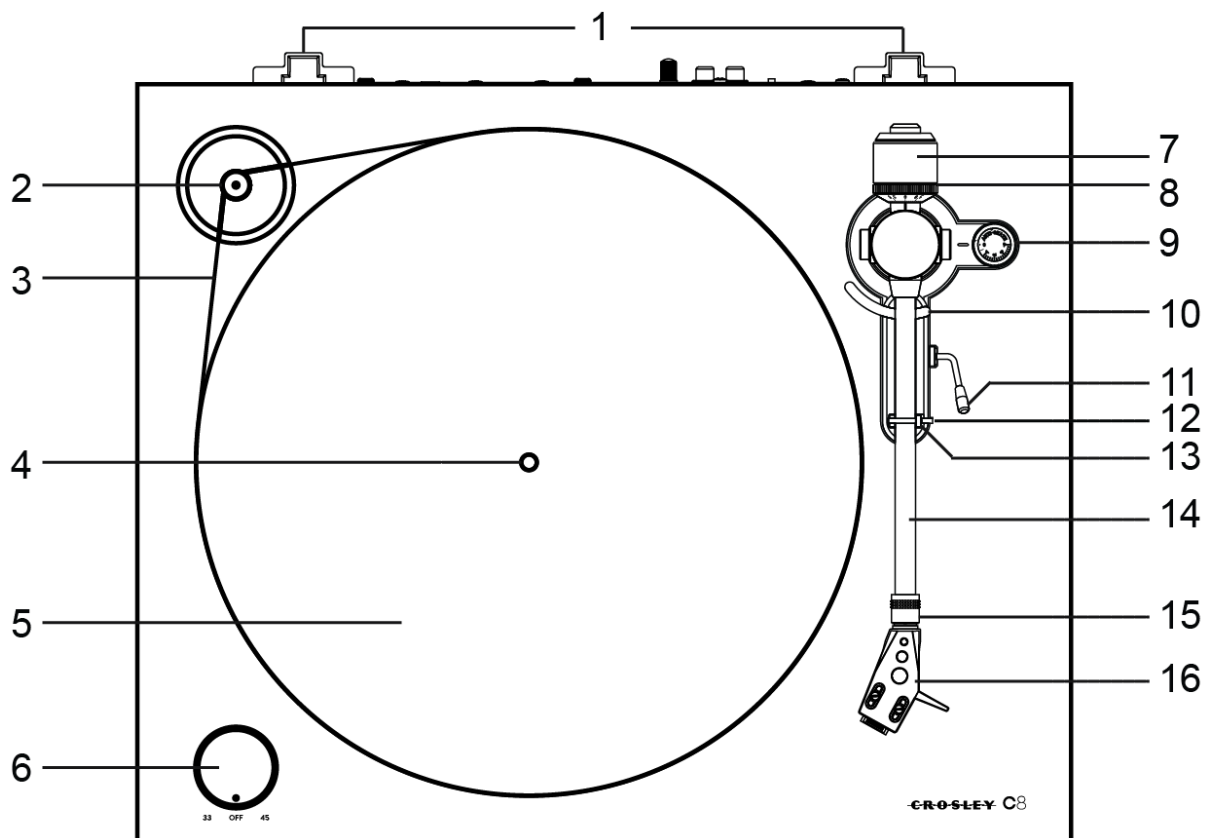

- |                               |                            |
|-------------------------------|----------------------------|
| 1. Hinge                      | 11. Cue Lever              |
| 2. Drive Pulley               | 12. Tonearm Rest           |
| 3. Drive Belt                 | 13. Hold Down Clip         |
| 4. Turntable Spindle          | 14. Tonearm                |
| 5. Turntable Platter          | 15. Headshell Locking Ring |
| 6. Speed Selector             | 16. Headshell              |
| 7. Tonearm Counterweight      | 17. Phone/Line Switch      |
| 8. Downforce Scale Dial       | 18. RCA Jacks              |
| 9. Anti-Skate Adjustment Dial | 19. Ground Connector       |
| 10. Tonearm Lift              | 20. Power Jack             |

## Initial Setup

---

### Essential Setup

1. Place the unit on a flat and level surface. The selected location should be stable and free from vibration.
2. Install the turntable lid to the hinges.
3. Remove the tie-wrap that is holding the tonearm.
4. Install the turntable platter and drive belt accordingly
5. Place the slip mat on top of the turntable platter.
6. Insert the Headshell into the socket at the front of the tonearm, and then turn the Headshell Locking Ring counter-clockwise. As the ring turns, it pulls the headshell into its seated position.
7. Slide **Tonearm Counterweight** onto tonearm and twist it lightly onto the rear shaft of the tonearm.
8. Adjust the counterweight to set proper stylus pressure.
9. Connect AC adaptor to the **Power Jack** of the unit.

*Note: Do not plug the AC power adaptor to power outlet before all the assembly is completed. Before turning the power on, make sure again all the connection settings are correct. Always turn off the power when connecting or disconnecting.*

### Tonearm Counterweight Adjustment for Stylus Pressure

1. Remove the stylus protector from the cartridge and avoid touching the stylus tip during the adjustment.
2. Lift up the **Tonearm** from its rest and gently hold it. The tone arm is unbalanced at this point.
3. Carefully rotate the **Counterweight** towards the front of the turntable until the tonearm is horizontally balanced and hovers freely just above the platter without the stylus touching the platter surface.
4. Return the tonearm to the **Tonearm Rest**.
5. While holding the counterweight steady without any rotation, rotate carefully only the **Downforce Scale Dial** until the "0" on the scale lines up with the centerline marked along the top of the tonearm.
6. Rotate the counterweight including the downforce scale dial counter-clockwise (as seen from the front of the turntable) to adjust the pressure to the stylus manufacturer recommendations.

*Note:*

- Each mark on the scale represents 0.1g (gram).
- The recommended pressure for the factory-installed cartridge is 3.5g.

### Turntable Platter and Belt Setup

1. Put the drive belt around the **Turntable Platter**, and then gently pull the belt to fit around the slot of motor pulley.

## Phono/Line Switch

---

For increased flexibility of use, this unit has a built-in stereo phono pre-amplifier. If you prefer to use the phono input of your stereo system or your standalone phono pre-amplifier, set the Phono/Line switch to the PHONO position. Otherwise, please set it to LINE position and make connection to the AUX input or other high-level input on your stereo system.

## Stereo System Connection

---

### RCA Jacks

- The RCA Jacks of this unit are shared as both the Phono output jacks and the Line output jacks. They are determined by the **Phono/Line Switch**.
- When used as a line output, the jacks output analog line-level signals and could be connected directly with a pair of active speakers or the appropriate input of your stereo system. When used as a Phono output, they should be connected to the phono pre-amp or the phono input of the stereo system.
- The Red plug connects with the Right channel and the White plug connects with the Left channel.

*Note:*

- If the Phono/Line switch is set at LINE position but RCA jacks connected to the stereo system's phono input, the sound might be distorted due to input overload and could damage your stereo system.
- If the Phono/Line switch is set at PHONO position but RCA jack connected to the stereo system's line input, the volume will be very low due to lacking signal pre-amplification.
- RCA Jack is not designed to be connected directly to the passive/unpowered speakers and if it does, the volume will be very low.

## Turntable Operation

1. Place the record on the turntable. Use the **45 RPM Adapter** if necessary.
2. Turn the Speed Selector to the desired speed.
3. Remove the stylus protector from the stylus assembly.  
*Note: To avoid stylus damage, make certain the included stylus guard is in place whenever the turntable is being moved or cleaned.*
4. Use the **Tonearm Lift Lever** to raise the **Tonearm Lift** and let the Tonearm sit on it, and move it over the record where play is desired to begin.
5. Set the **Tonearm Lift Lever** back to the down position, the tonearm will descend slowly onto the record and begin playback.
6. When the record is finished playing, use the **Tonearm Lift Lever** to raise the tonearm and then return it to the **Tonearm Rest**. To suspend the playback, repeat the same steps.

## Anti-Skate Adjustment

- A small outward “anti-skating” force can be applied to the tone arm to compensate for the “skating” force that pulls the arm toward the center of the record.
- For best performance during normal turntable usage, it is recommended to set the anti-skate control knob to the same value as indicated by the downforce scale dial.

## Needle Replacement

### Removing Needle

1. Gently pull down the front edge of the needle.
2. Pull needle forward.
3. Pull out and remove.

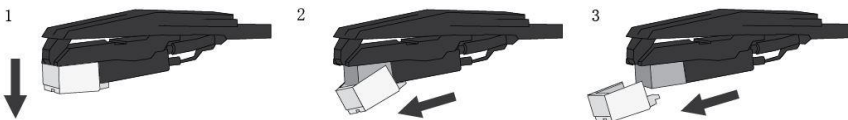

### Installing Needle

1. Position the needle with its tip facing down.
2. Line up the back of the needle with the cartridge.
3. Insert the needle with its front end at a downward angle and gently lift the front of the needle upward until it snaps into place.

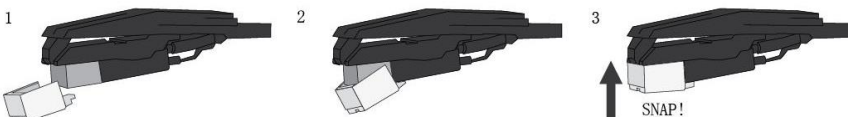

## Cartridge Replacement

1. Before replacement, put the stylus protector back on the stylus to prevent damage to the stylus during the replacement process.
2. Carefully remove the wire leads from the original cartridge.
3. Loosen the two screws on the headshell that are securing the cartridge and then remove the original cartridge.
4. Mount the new cartridge to the headshell and tighten it lightly. Do not completely tighten the screws at this moment.
5. Connect the wire leads to the new cartridge's terminals. The wire lead color codes are as below:
 

White	Left channel positive	(L+)
Blue	Left channel negative	(L-)
Red	Right channel positive	(R+)
Green	Right channel negative	(R-)
6. Adjust the cartridge's position to make sure it is precisely aligned on the headshell so that the stylus will be tracking the grooves in parallel perfectly.
7. Tighten the screws completely once the perfect alignment is achieved.

---

## Turntable Maintenance

---

1. Do not touch the stylus tip with your fingers. Avoid bumping the stylus on the turntable mat or a record's edge.
2. Clean the stylus frequently with a soft brush with a back-to-front motion only.
3. Clean the records to get rid of dust or grease with a record cleaning brush and record cleaning solution.
4. Clean the turntable lid and turntable cabinet with a slightly dampened microfiber cloth.

*Note: Do not use cleanser other than that contains alcohol, benzene or any other harsh chemicals, which might damage the paint and finish of the turntable.*

**\*\* Crosley offers a product line of different cleaning accessories. Please ask your retailer or check out our website [www.crosleyradio.com](http://www.crosleyradio.com) for more cleaning product information.**

---

## Troubleshooting

---

### There is no power

- Power adaptor is not connected correctly.
- No power at the power outlet.

### Power is on, but the platter does not turn

- Turntable's drive belt is not installed or has slipped off.

### Turntable is spinning, but there is no sound, or sound not loud enough

- Stylus protector is still on.
- Tone arm is lifted up by the lever.

### Record sounds too fast or too slow.

- Wrong speed selected for the record.

### Strong hum on phono input

- The cable is not grounded correctly

---

## FCC Statements

---

This equipment has been tested and found to comply with the limits for a Class B digital device, pursuant to Part 15 of the FCC Rules. These limits are designed to provide reasonable protection against harmful interference in a residential installation. This equipment generates, uses, and can radiate radio frequency energy and, if not installed and used in accordance with the instructions, may cause harmful interference to radio communications. However, there is no guarantee that interference will not occur in a particular installation. If this equipment does cause harmful interference to radio or television reception, which can be determined by turning the equipment off and on, the user is encouraged to try to correct the interference by one or more of the following measures:

- Reorient or relocate the receiving antenna.
- Increase the separation between the equipment and receiver.
- Connect the equipment into a circuit different from that to which the receiver is connected.
- Consult the dealer or an experienced radio TV technician for help.