











ASSEMBLY INSTRUCTION

DESCRIPTION: SOFA TABLE

Thank you for purchasing this quality product. Be sure to check all packing material carefully for small parts, which may have come loose inside the carton during shipment. Identify and count all parts and compare with the parts list below.





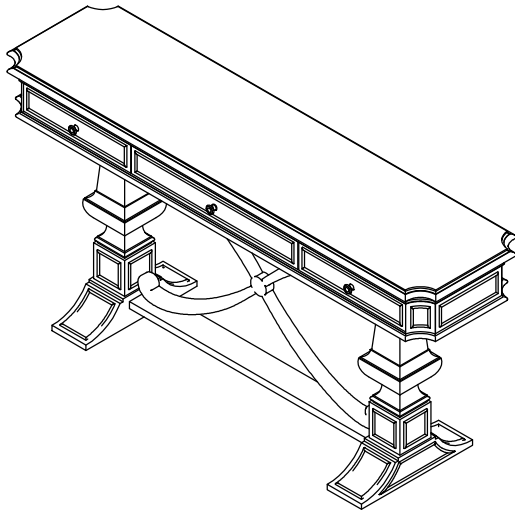

HARDWARE LIST

NO	DRAWING	DESCRIPTION	QTY
1		Hanger Bolt Ø5/16"*85mm	2 pcs
2		Double hex nut Ø5/16"*12mm	2 pcs
3		Curved washer	2 pcs
4		Wrench 5/16"	1 pc
5		Bolt Ø5/16"*35mm	14 pcs
6		Bolt Ø5/16"*100mm	4 pcs
7		Spring Washer Ø5/16"	18 pcs
8		Flat Washer Ø5/16"*Ø19*1.5mm	18 pcs
9		Wood Dowel Ø8*30mm	8 pcs
10		Allen Key 110*23*4mm	1pc
11		Tipping Restraint Kit	1Set



Complete Assembly

PART LIST

NO	DRAWING	DESCRIPTION	QTY
A		Top	1pc
B		Legs	2pcs
C		Base	2pcs
D		Decor stretcher	1pc
E		Mounting plate	1pc
F		Stretcher	1pc

STEP 1

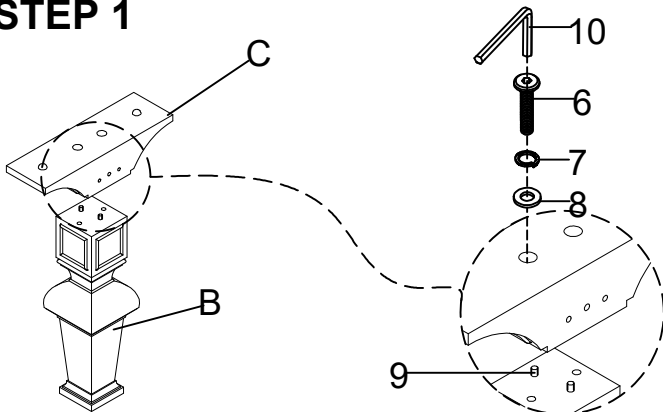

STEP 2

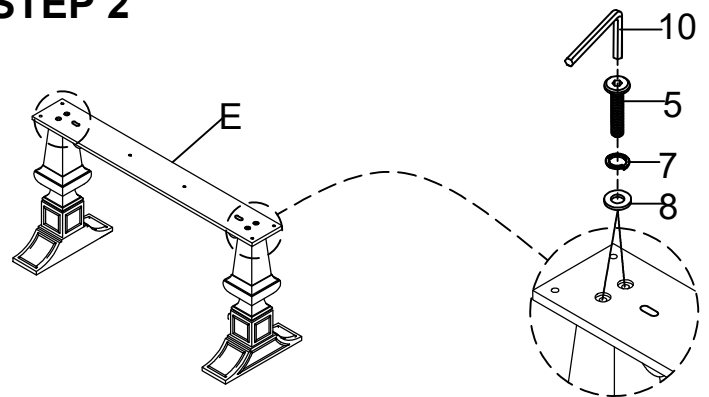

STEP 3

NOTE: Assemble Decor stretcher

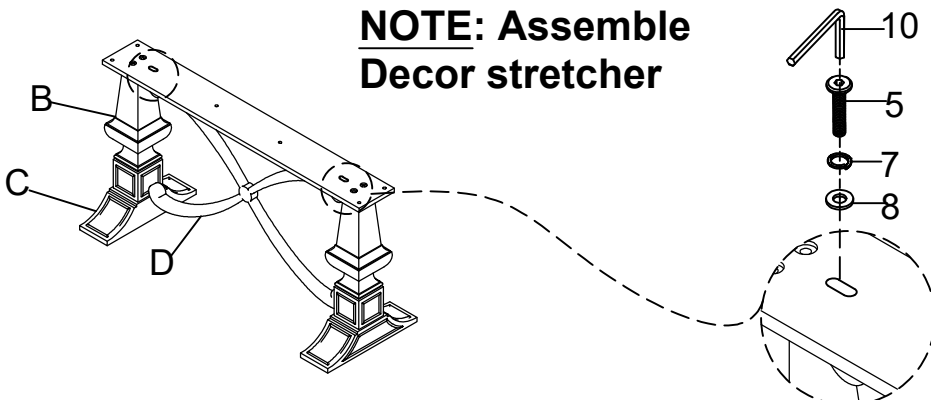

ASSEMBLY INSTRUCTION

DESCRIPTION: SOFA TABLE

Thank you for purchasing this quality product. Be sure to check all packing material carefully for small parts, which may have come loose inside the carton during shipment. Identify and count all parts and compare with the parts list below.

STEP 4

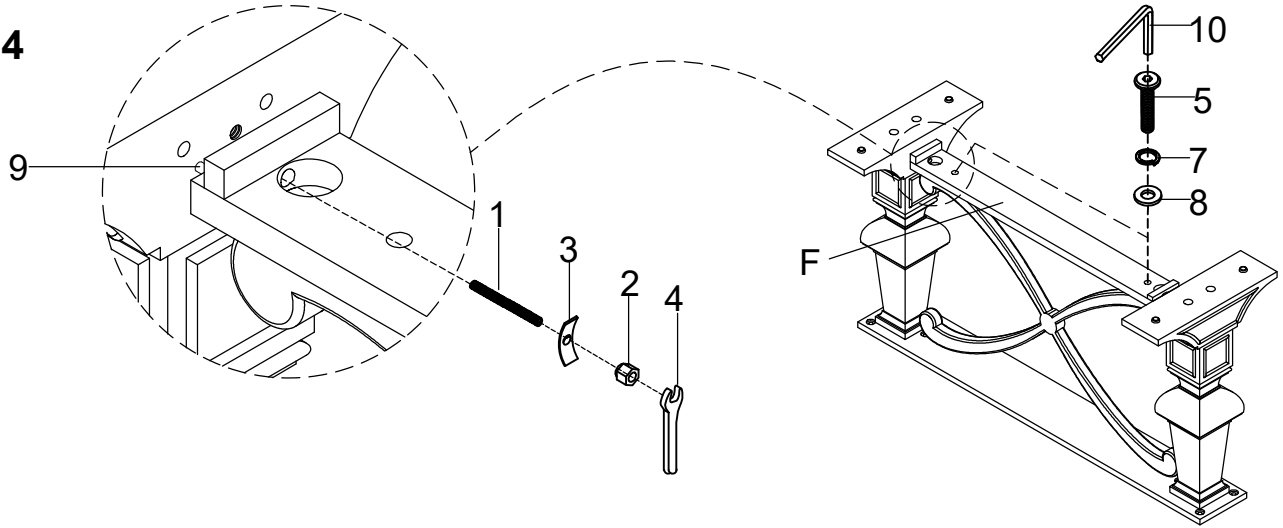

STEP 5

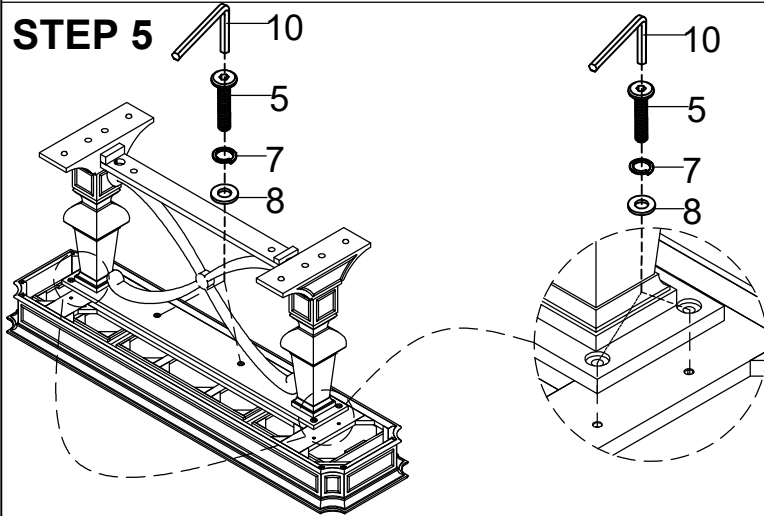

STEP 6

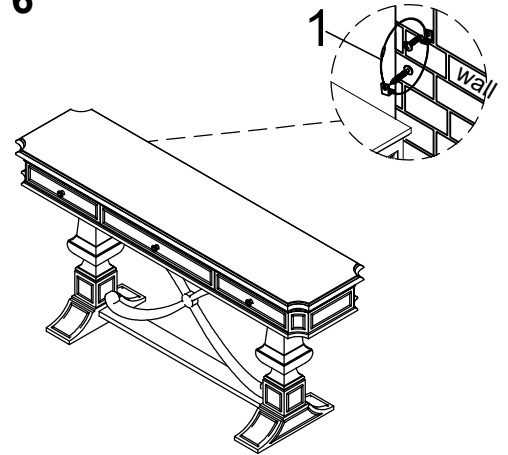

Push tab down
to remove drawer



HOW TO REMOVE DRAWER

To remove drawer, simultaneously pull tab up on one side and put down on the other and remove drawer.

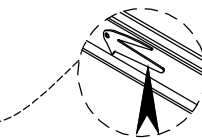
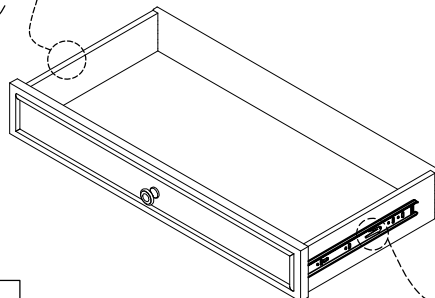

Push tab up
to remove drawer