

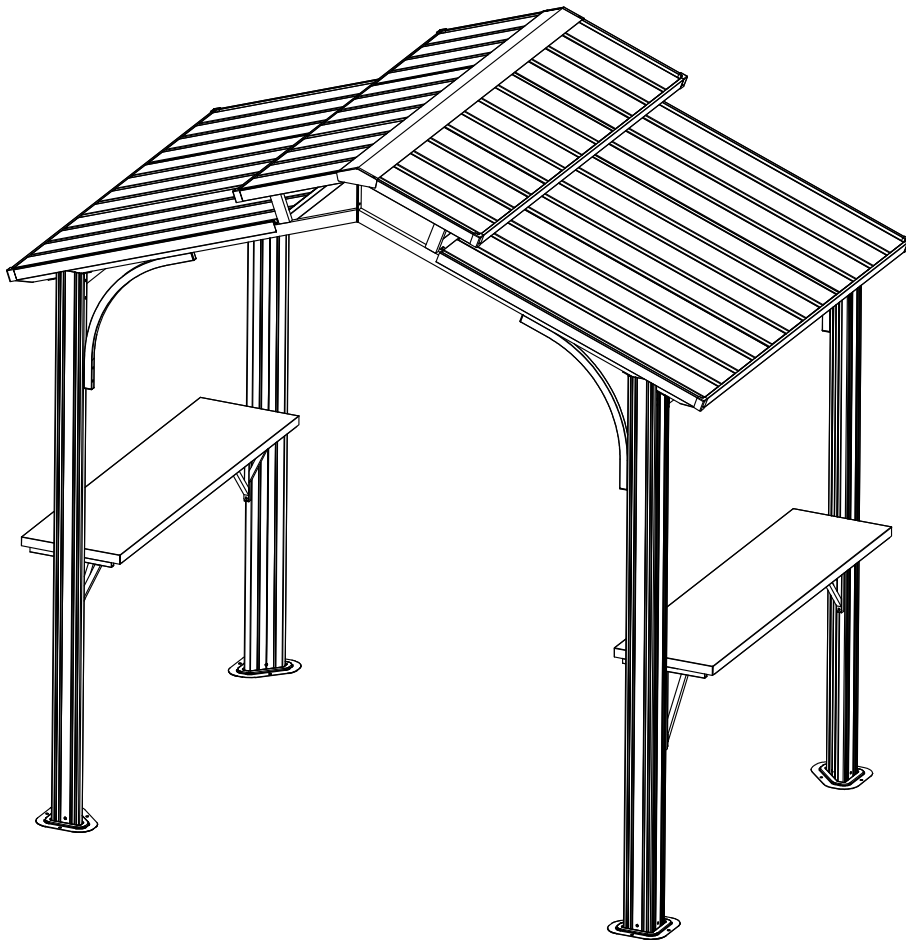

8' x 5' Metal Grill Gazebo

ASSEMBLY MANUAL



MODEL#:LGMF 1651

Missing part? Damaged? Contact us via email at

service@domioutdoorliving.com

www.domioutdoorliving.com

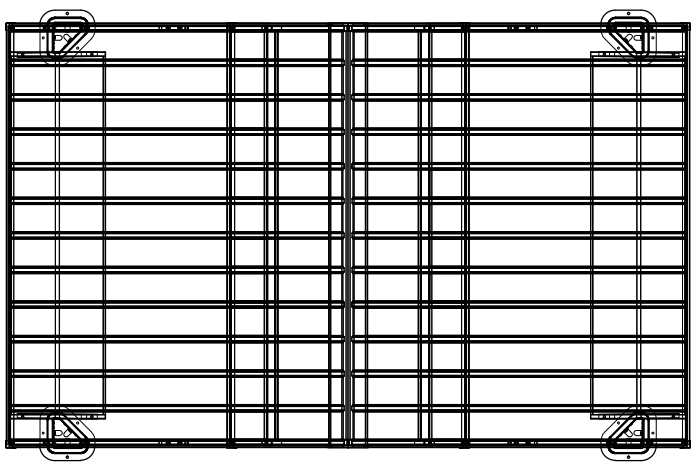
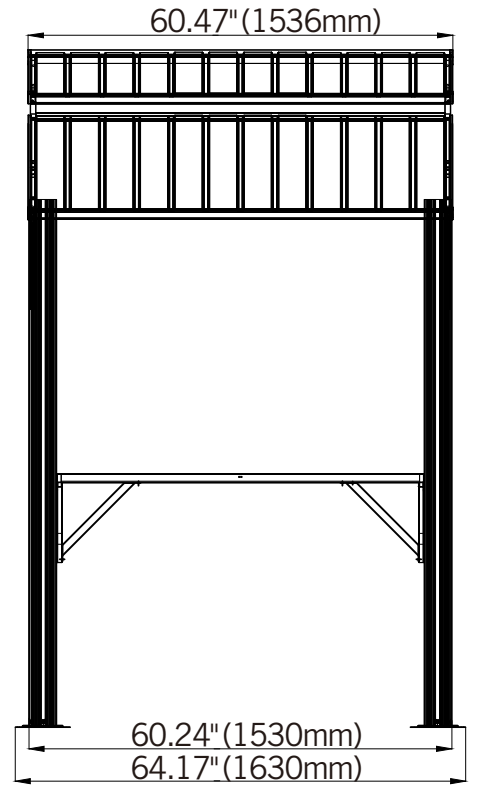
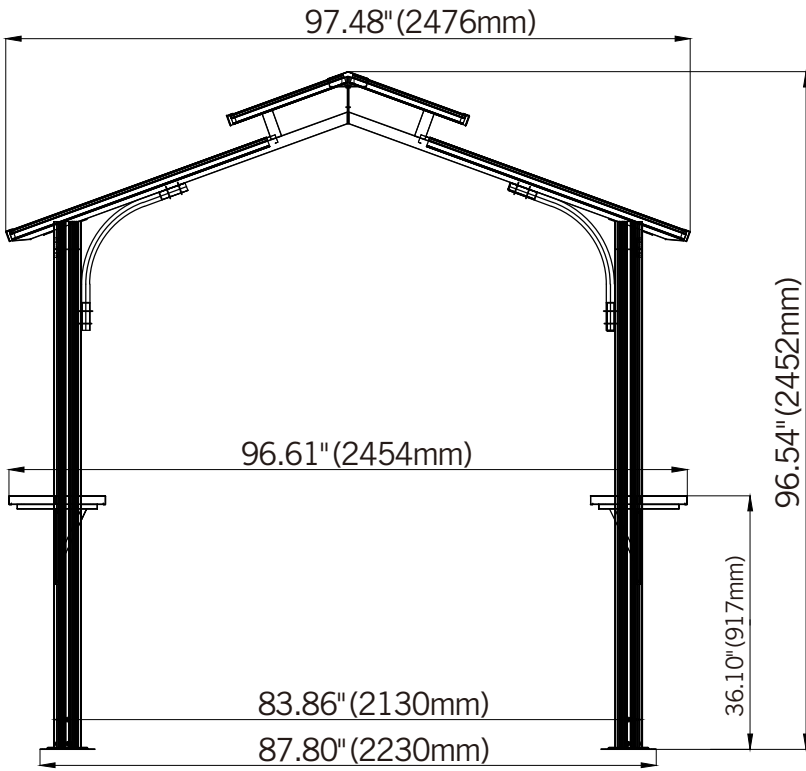

1

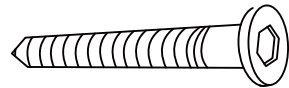
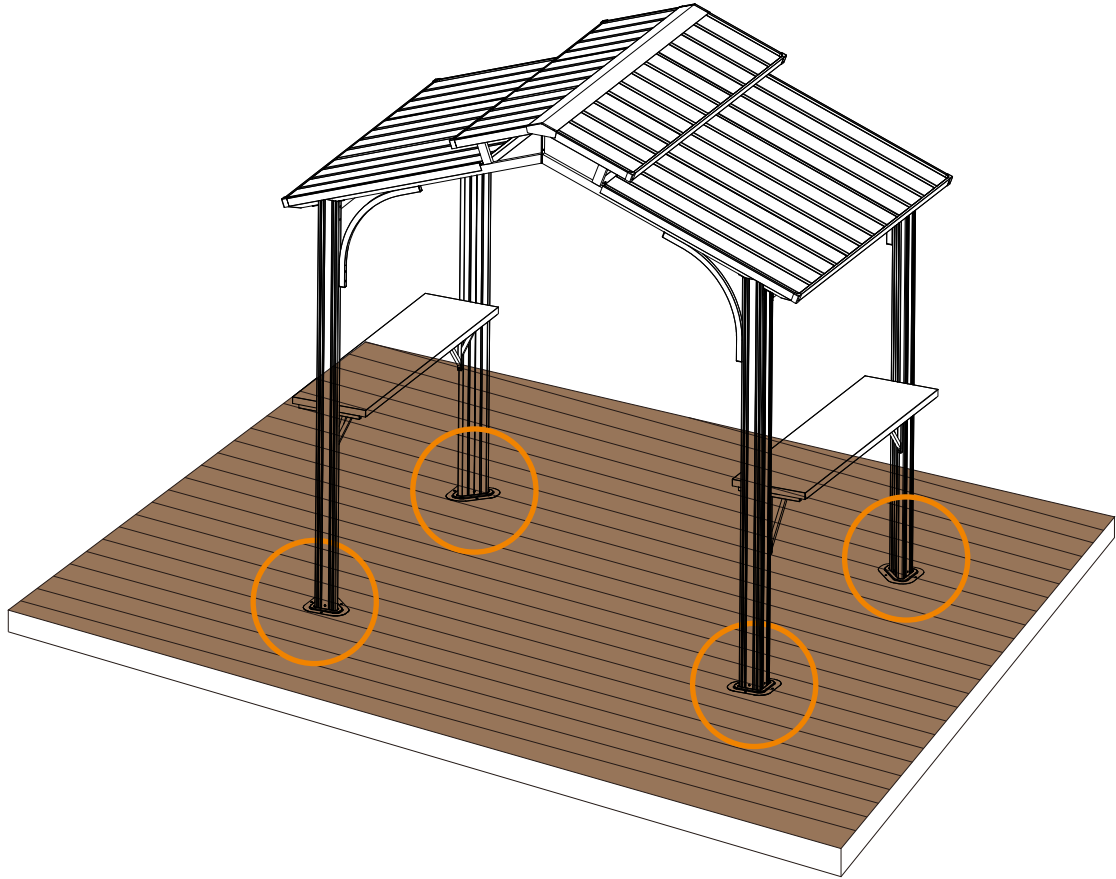

×12

If the deck is hard wood and the depth of it is over 3 inch, you can use **5/16 in. ×4 in. Structural Wood Screw** to mount the gazebo.

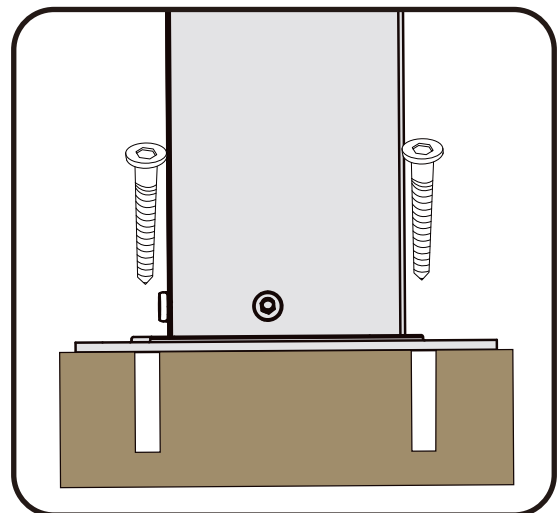
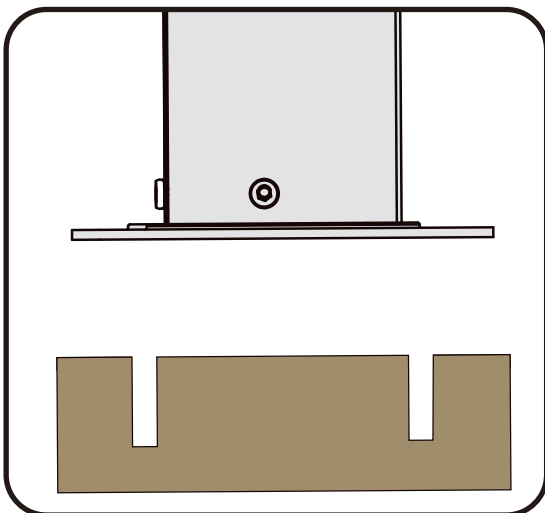

2

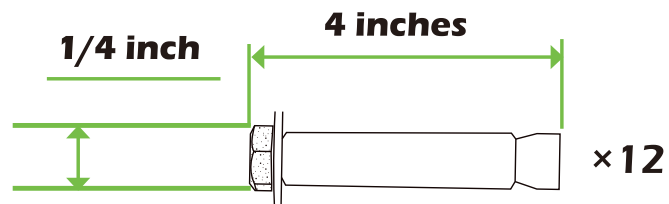
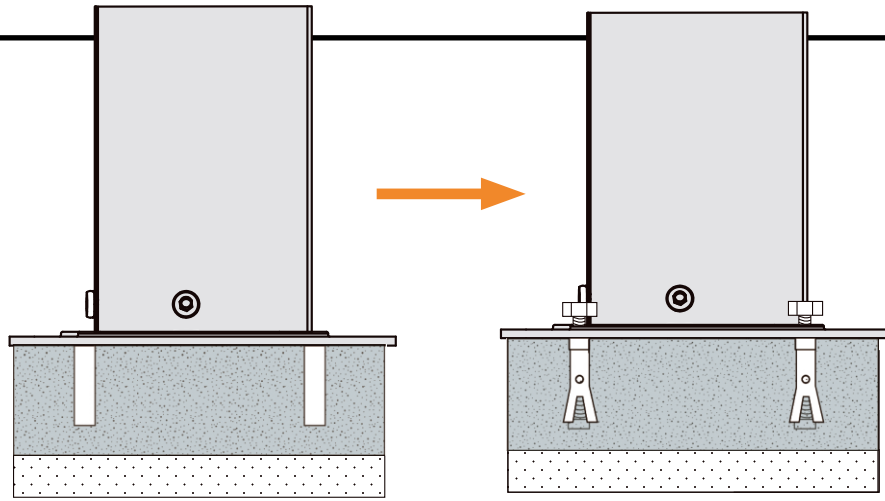

If the ground is concreted and the depth of it is over 3 inch, you can use 1/4 inch expansion bolts to mount the gazebo



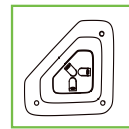
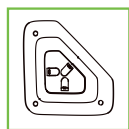





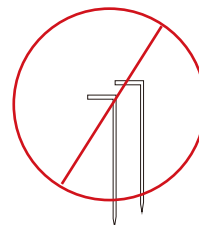



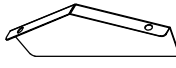
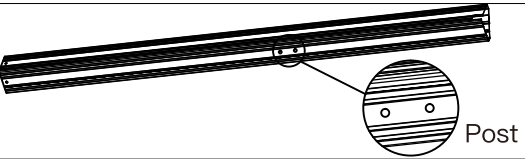
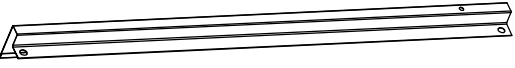
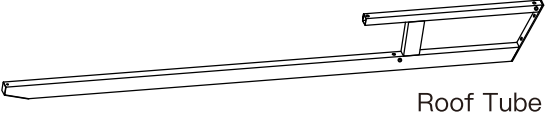

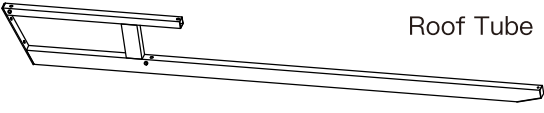
3

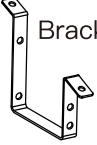

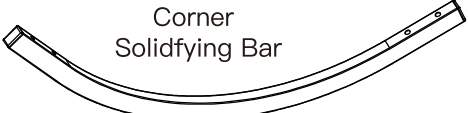
Or you can make a concrete footing for gazebo, **15×15×15 inches** is recommended. use expansion bolts to mount the pergola like (2) shows.

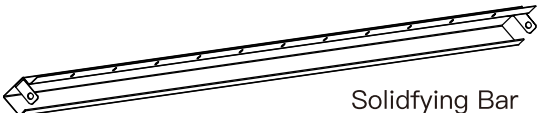
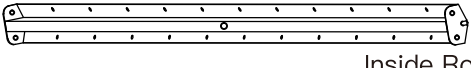
IMPORTANT:
Anchor is not recommended

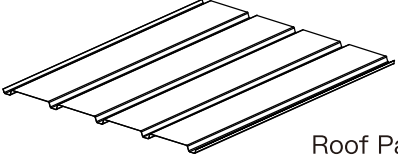
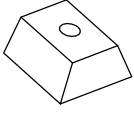

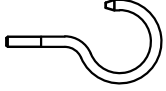
A		2	K		4
A1		1	L		2
A2		1	M		2
B		2	M1		2
B1		2	N		4
C		4	D		4
E		4	E1		4
F		4	Q		2
G		2	R		2
H		1	S		1
I		6	T		26
J		6	U		1
			V		1
2					

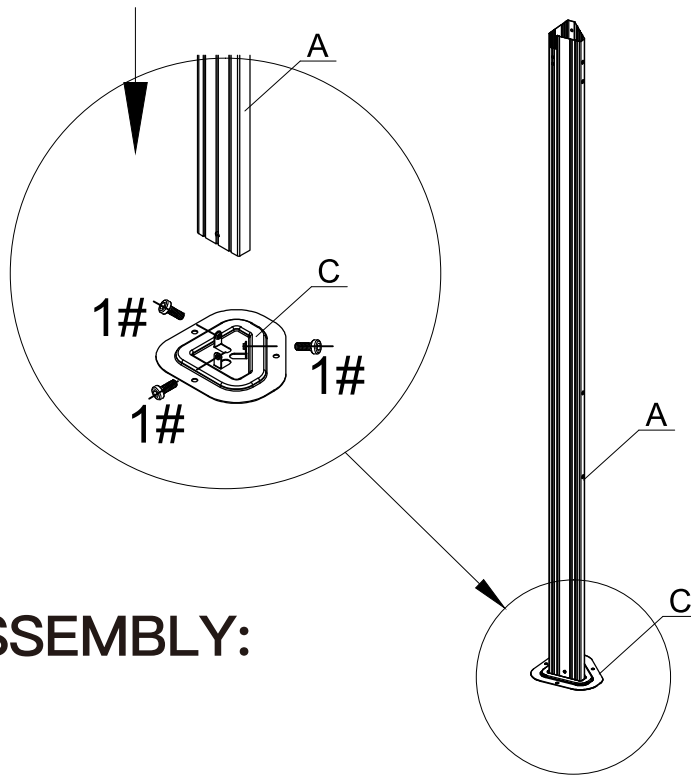
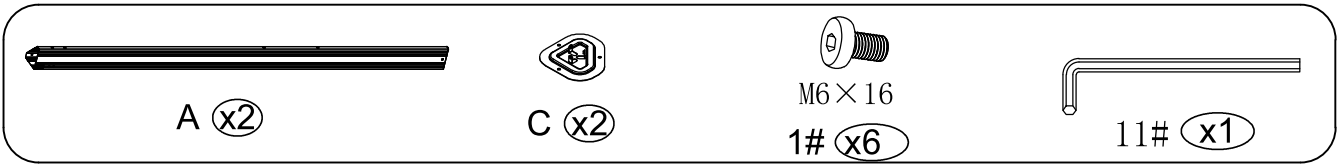

2X

POST ASSEMBLY:

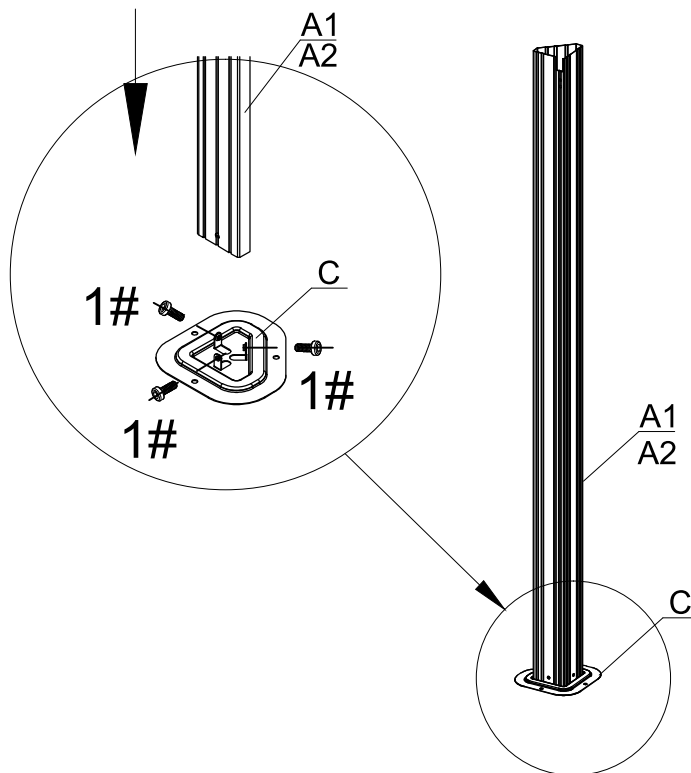
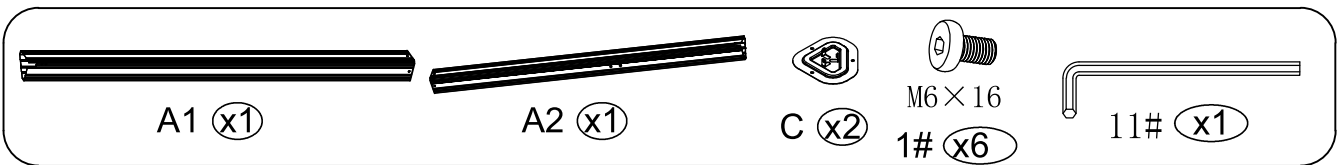

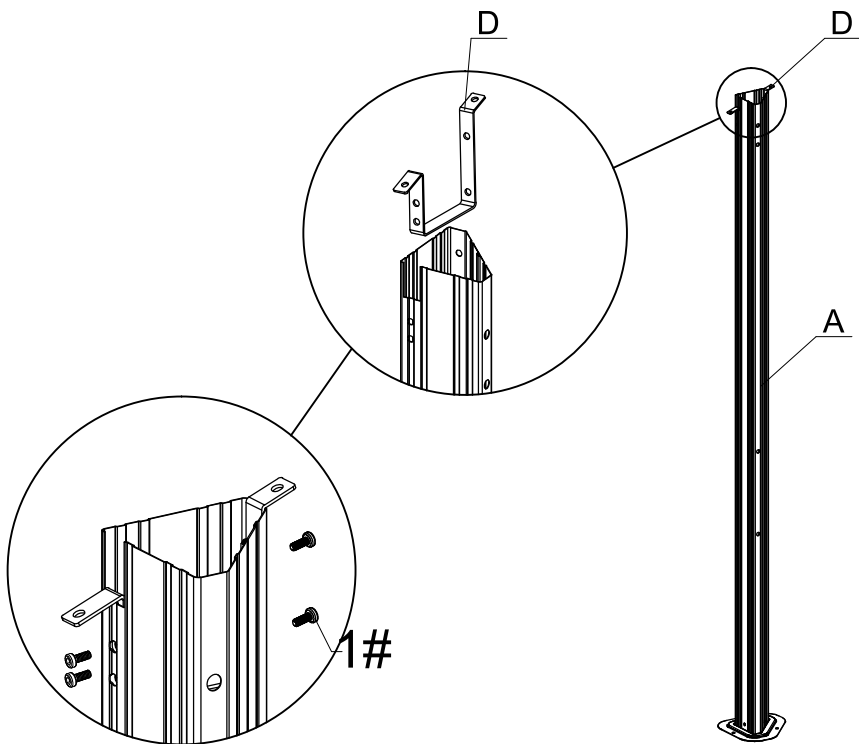
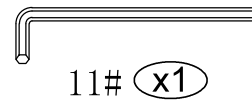
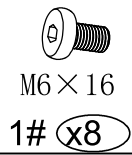
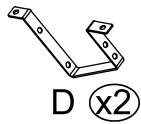

2X

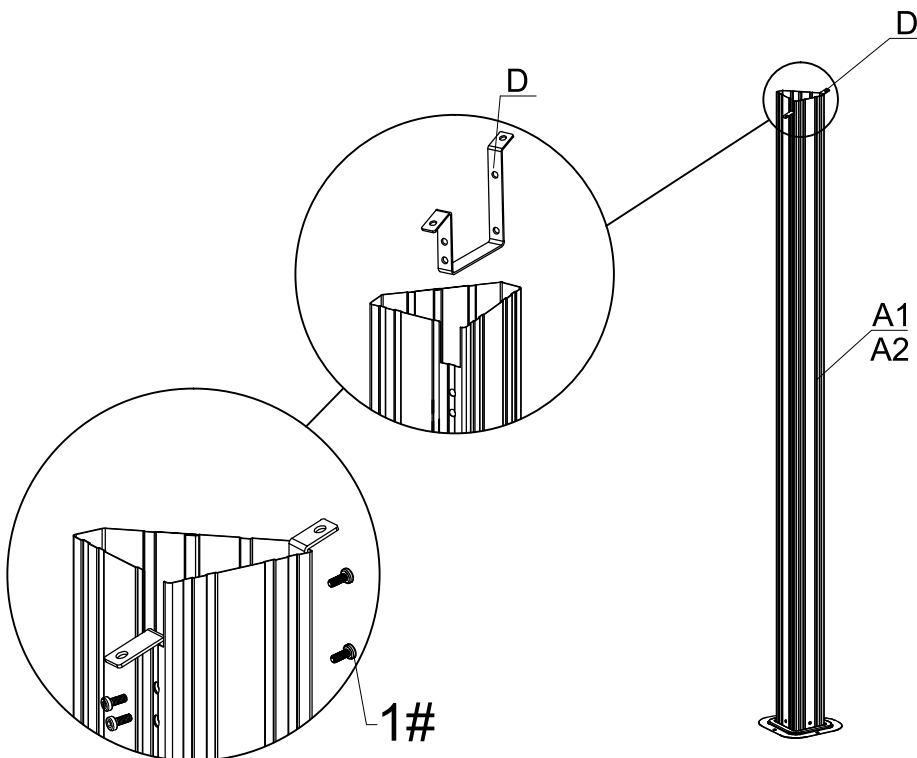
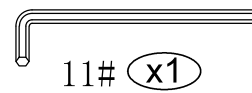
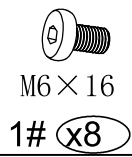
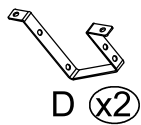

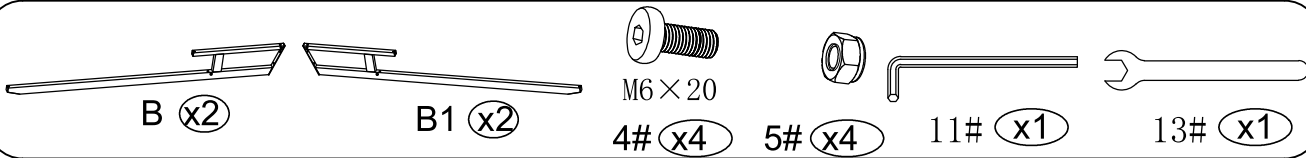

ROOF TUBE ASSEMBLY:

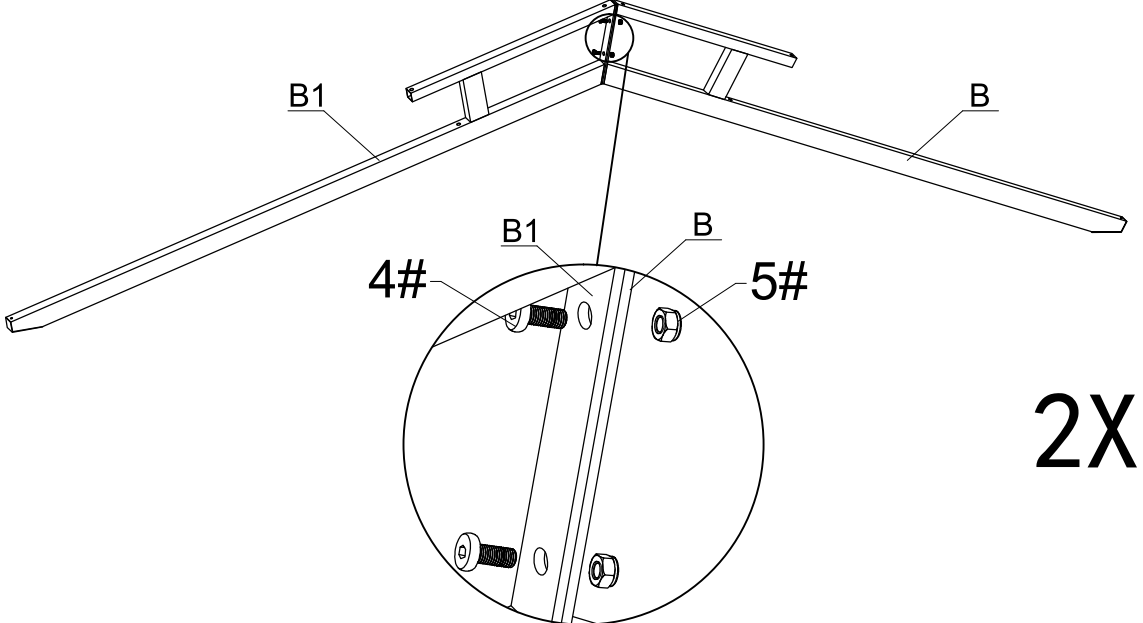

The only difference between A1 & A2 is that there are two holes on A2, which are used to assemble the bottle opener.

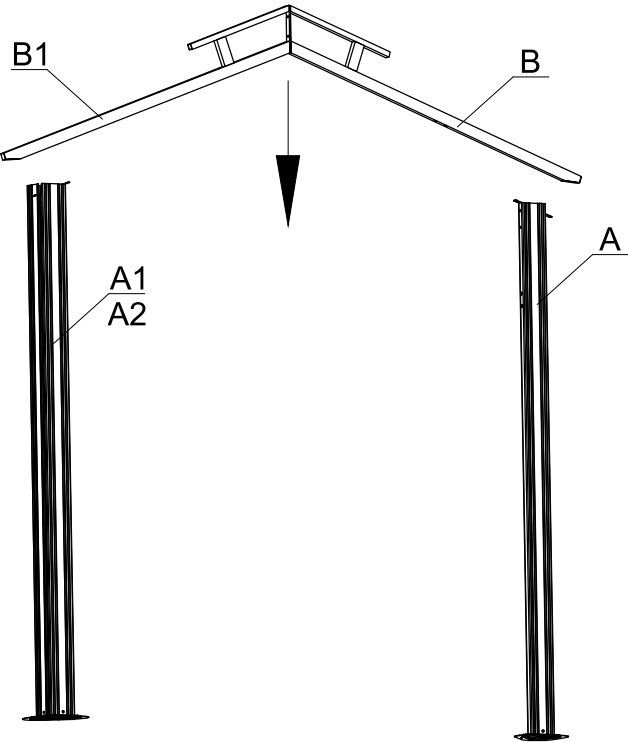



M6 x 16

1# x8



11# x1

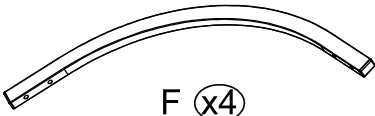
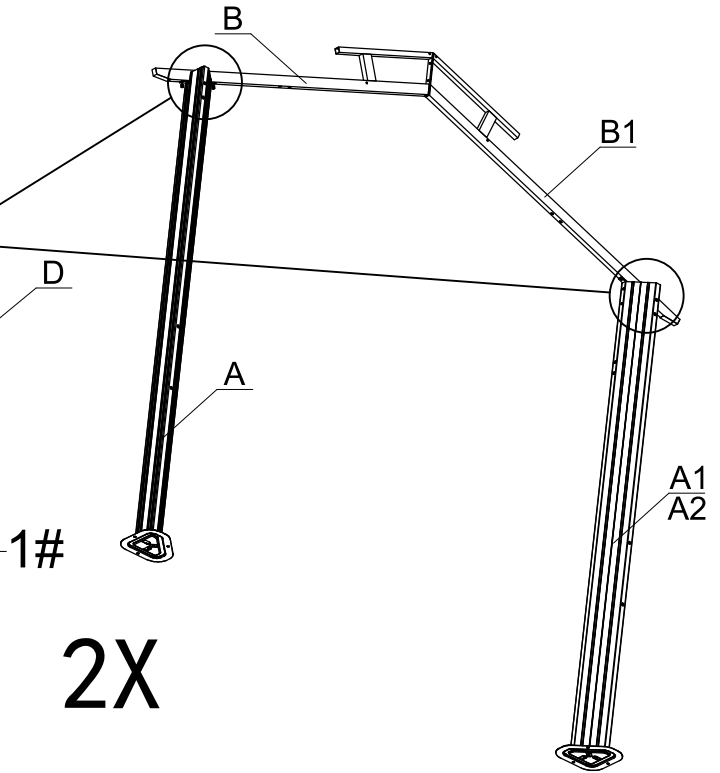
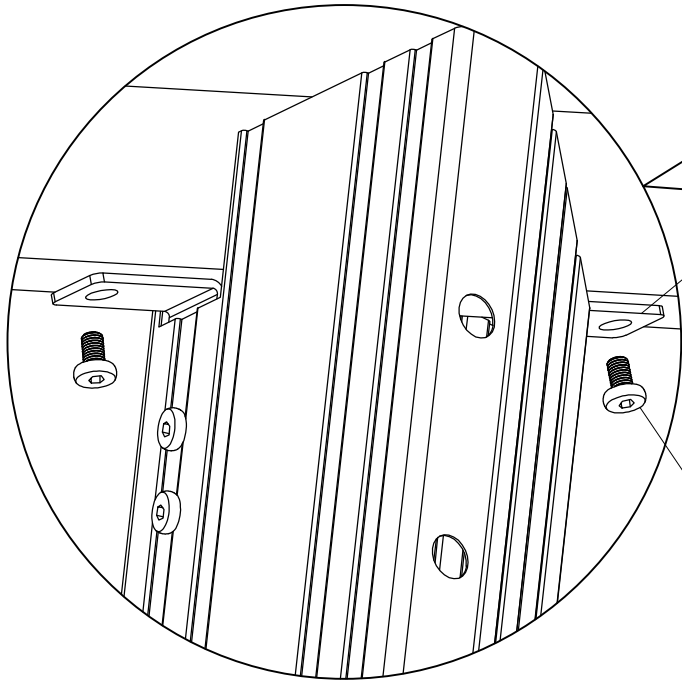

F x4



M6 x 45

2# x16

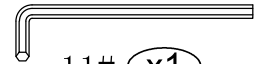

11# x1

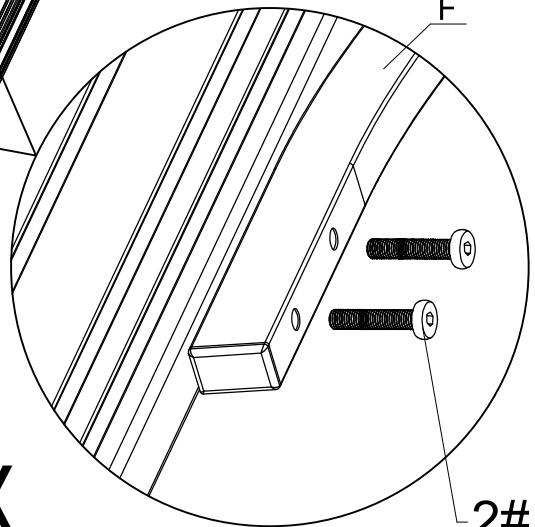
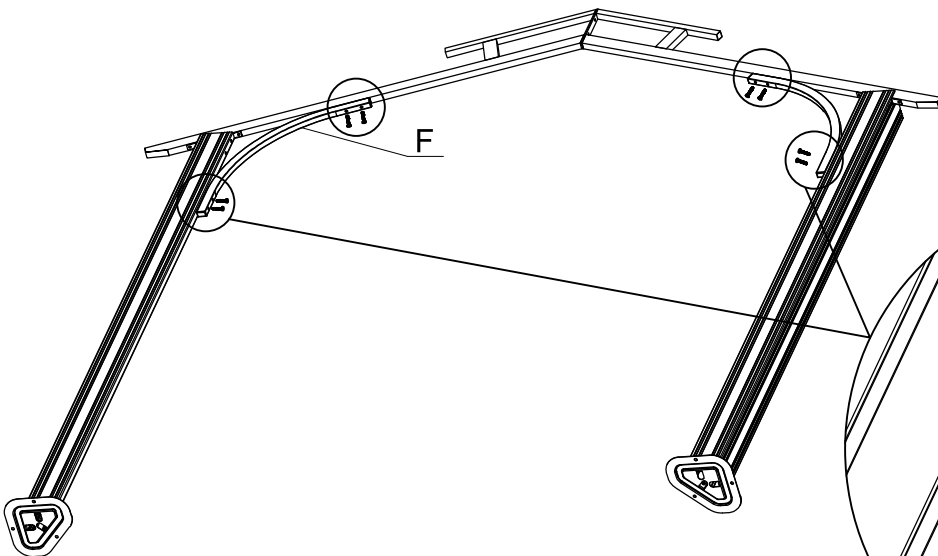

2#



BEAM ASSEMBLY:

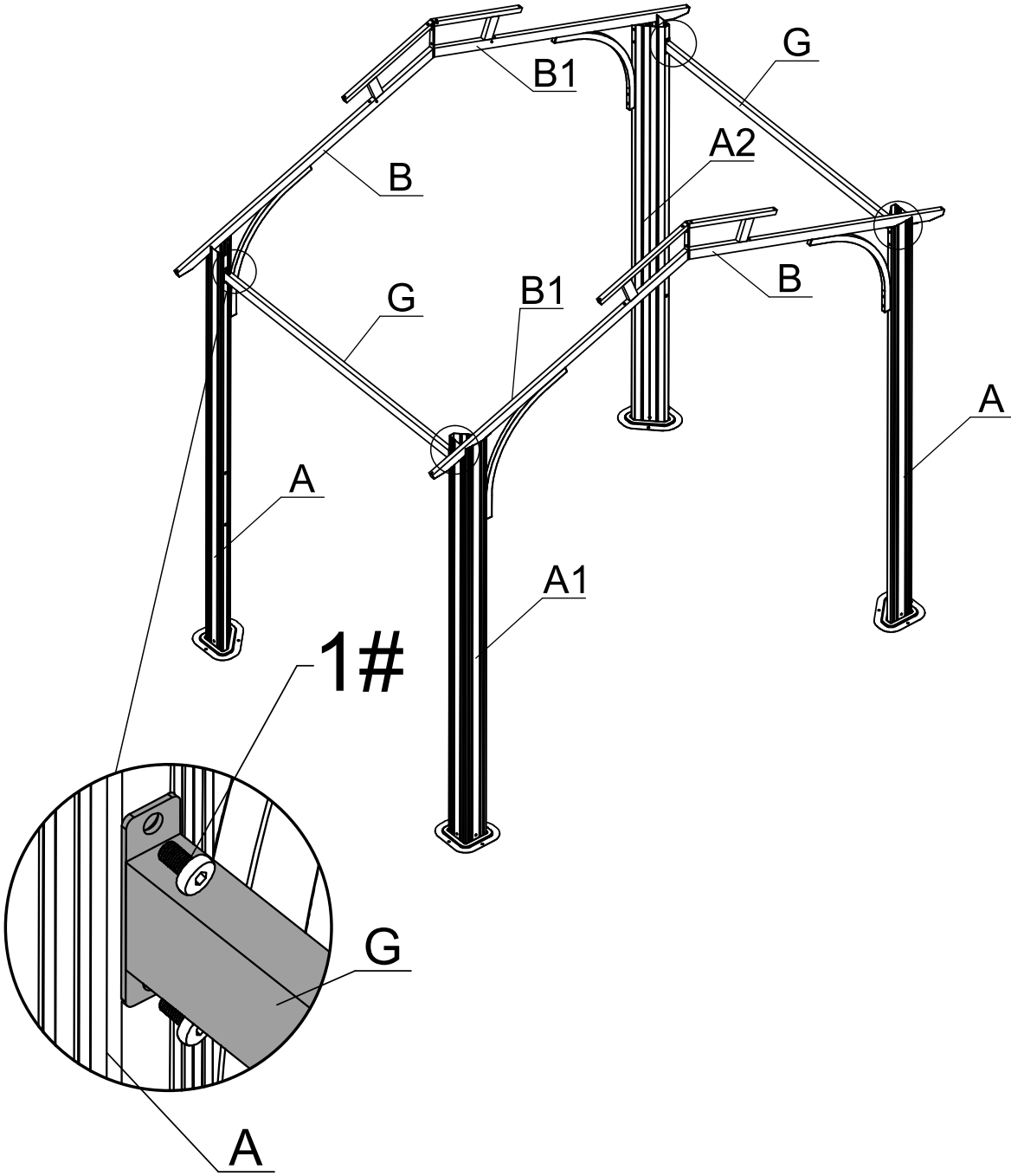

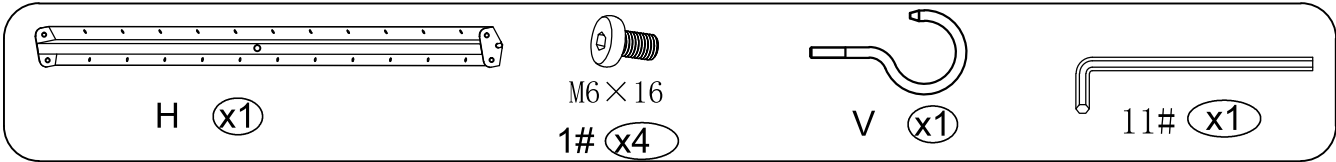

INSIDE ROOF COVER & J-HOOK ASSEMBLY:

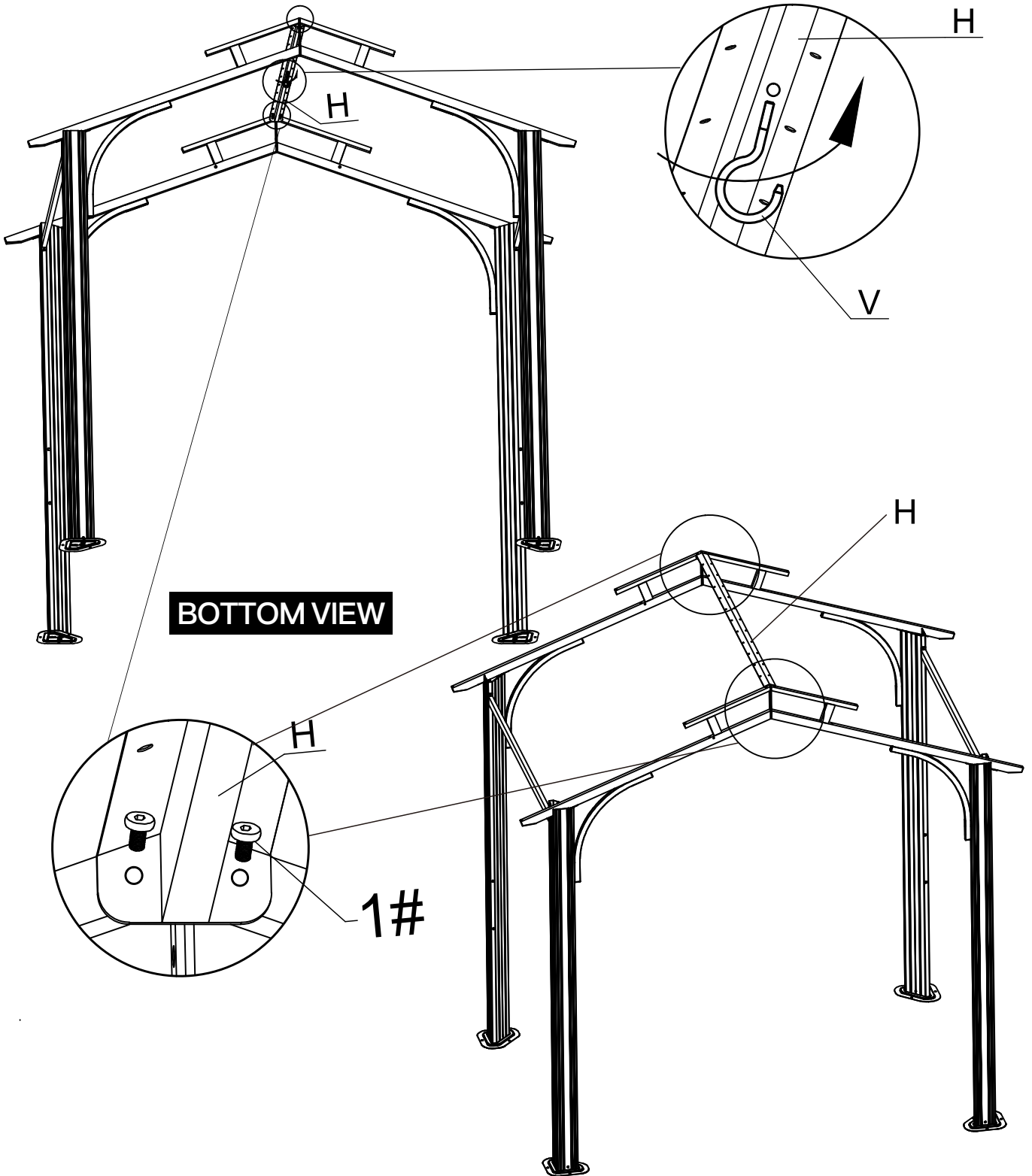

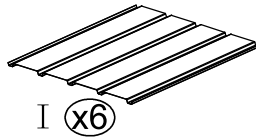
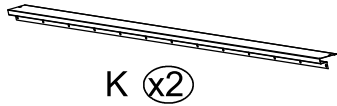

ROOF ASSEMBLY:

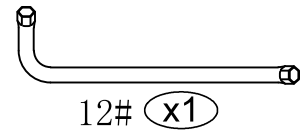
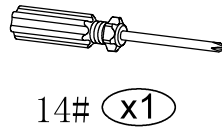
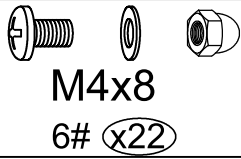
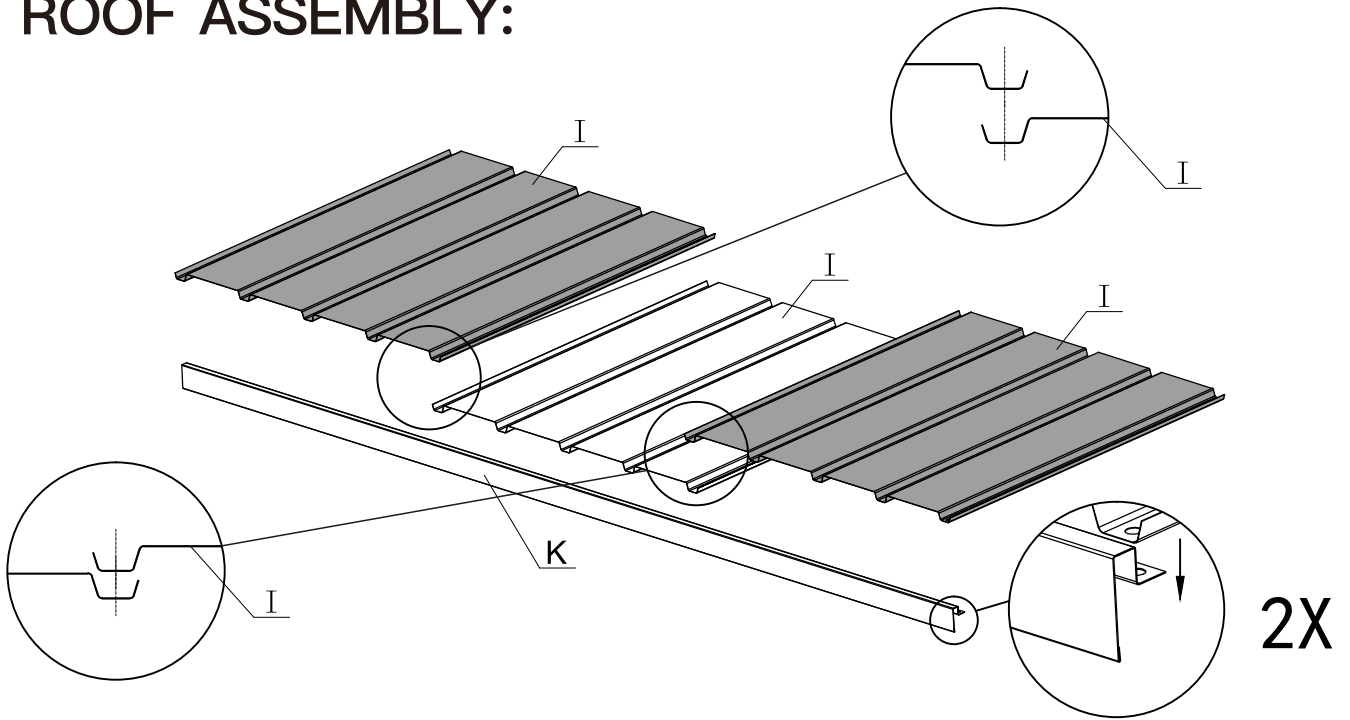

2X

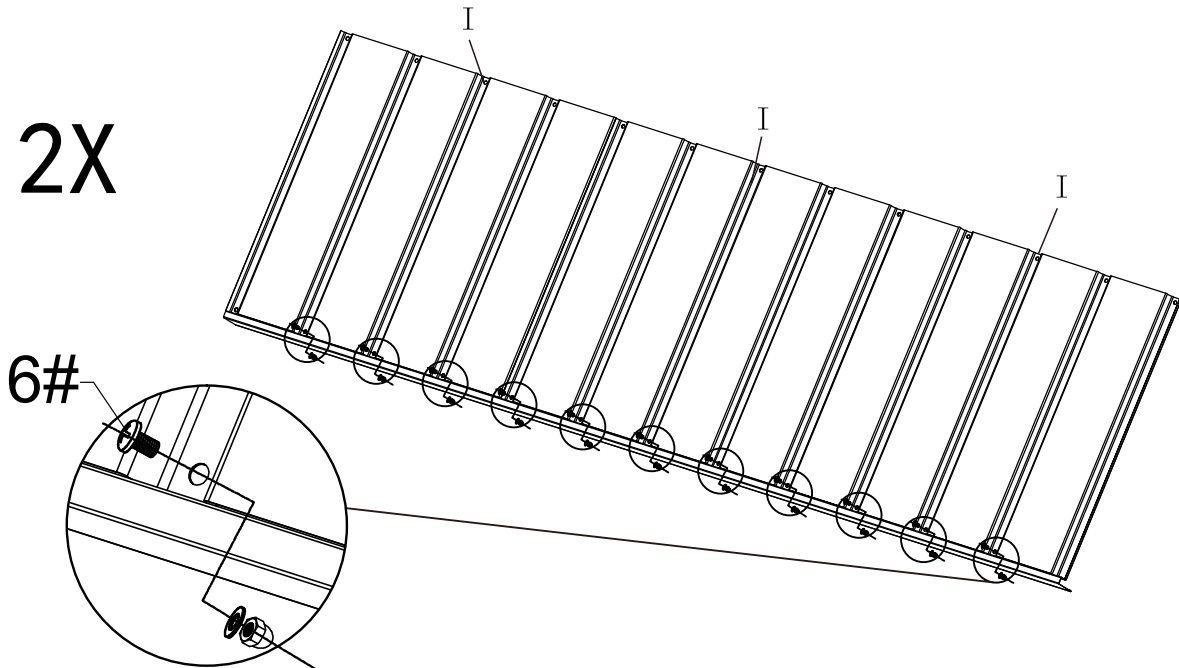

Place 3 roof panel #I ON the finishing bar and secure with 11 bolts #6, gaskets and nuts.
Repeat the above procedures to assemble another side.

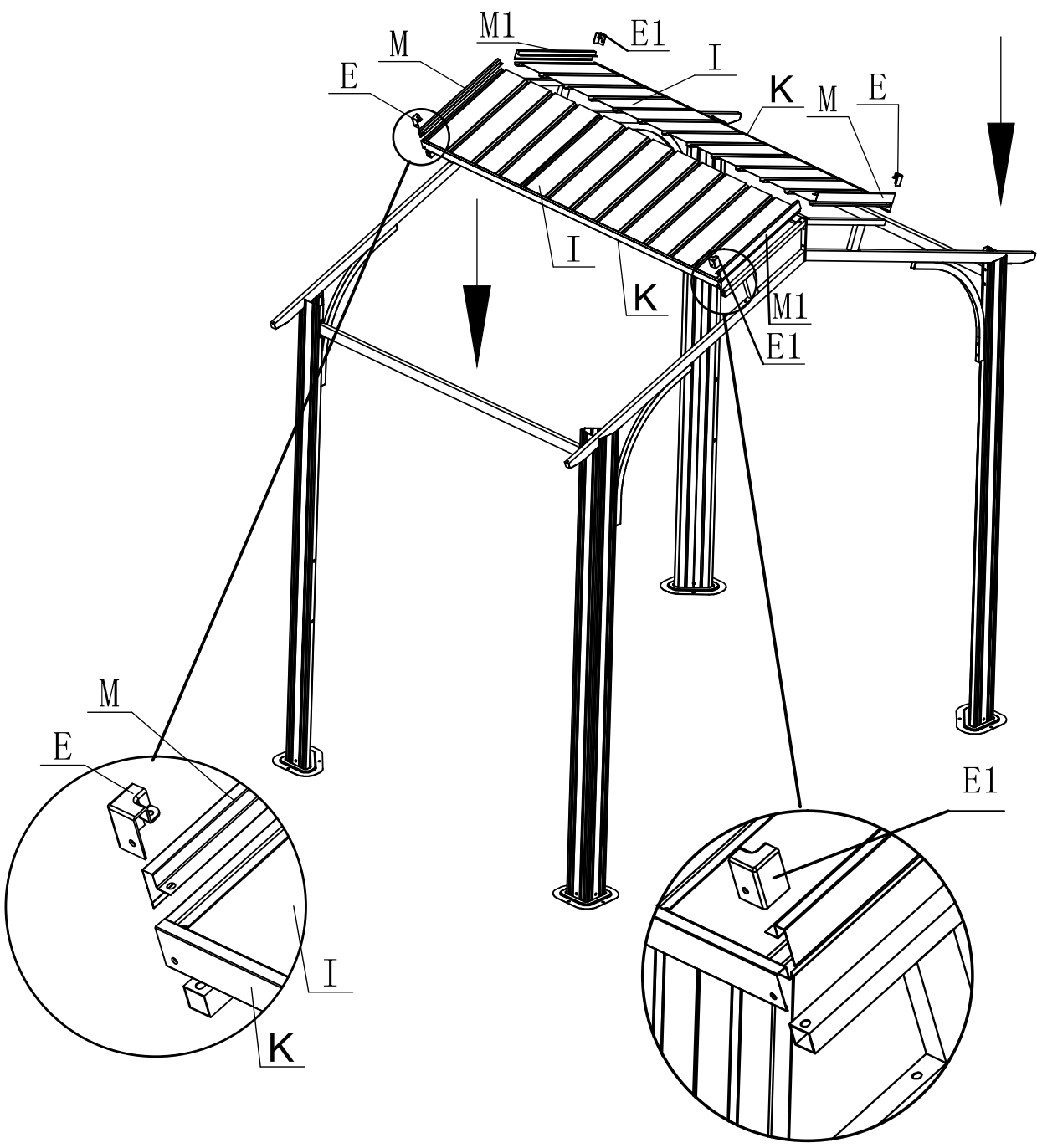
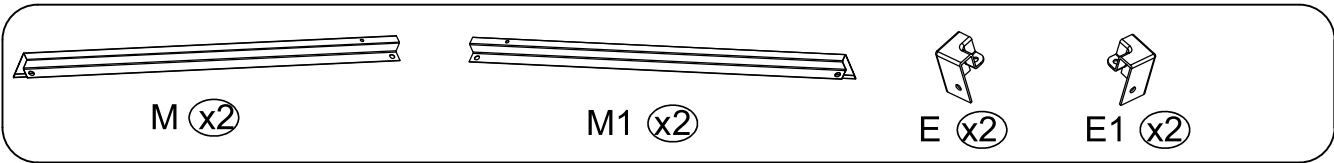

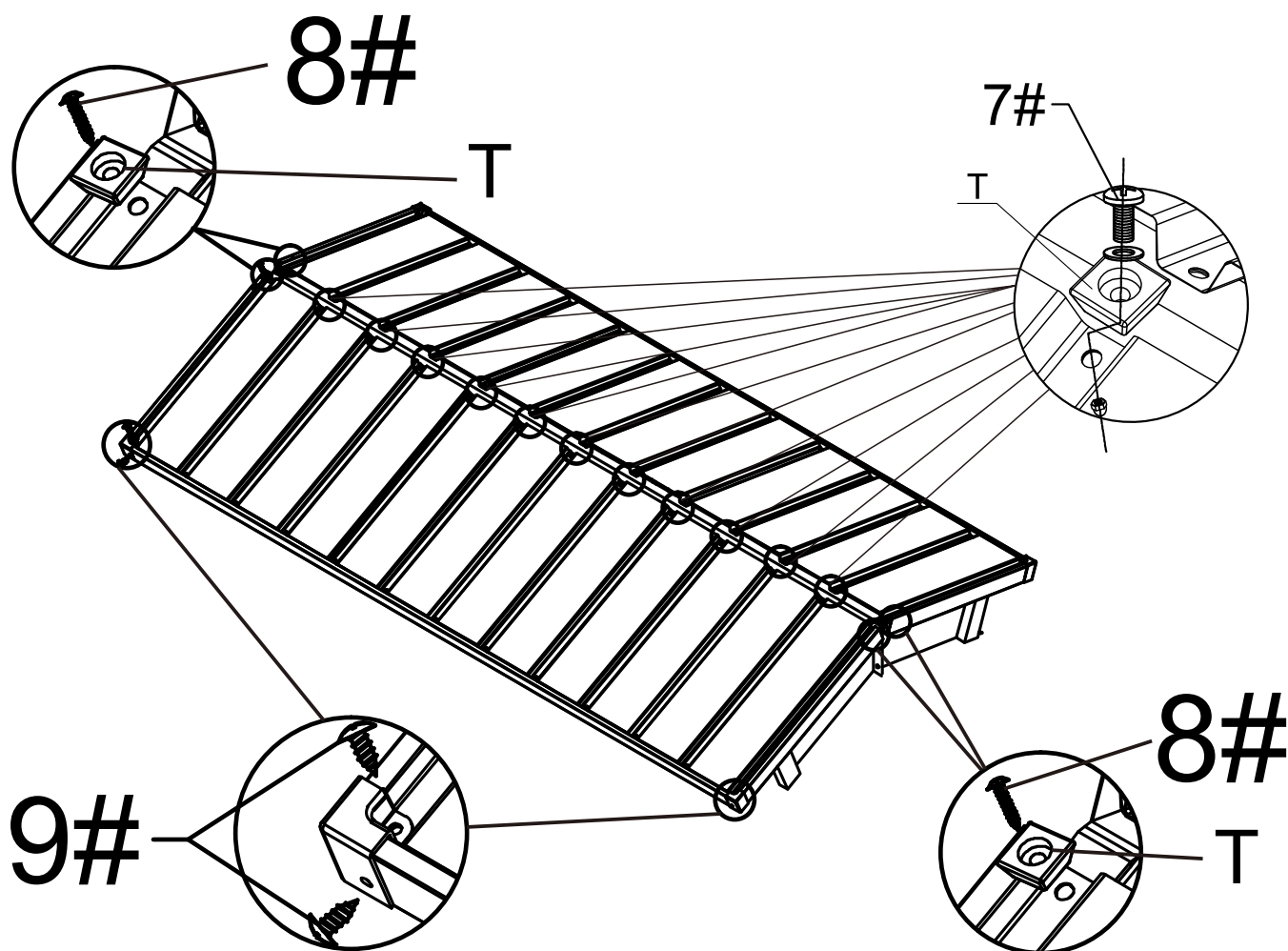
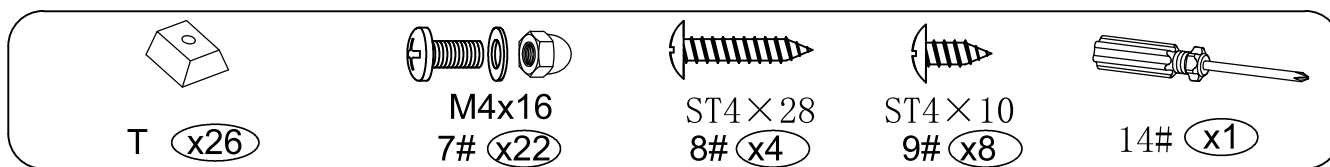

Step1: Insert 11 black rubbers #T to the gap of the roof panel,use 11 bolts #7,gaskets and nuts to fix roof panel to the inside roof cover #H. Repeat the above procedures to assemble the opposite side.

Step2: Use 2 bolt #8 and black rubbers #T to fix part #M and #M1 to the inside roof cover #H. Repeat the above procedures to assemble the opposite side.

Step3: Use 2 self-tapping bolts #9 and fixing end #E to fix part #K and #M, Use 2 bolt #9 and fixing bracket #E1 to fix part #K and #M1 . Repeat the above procedures to assemble the opposite side.

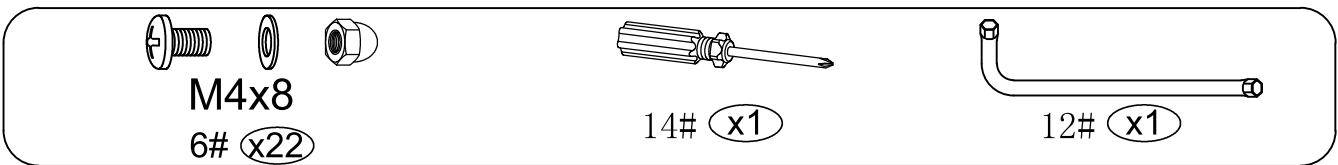
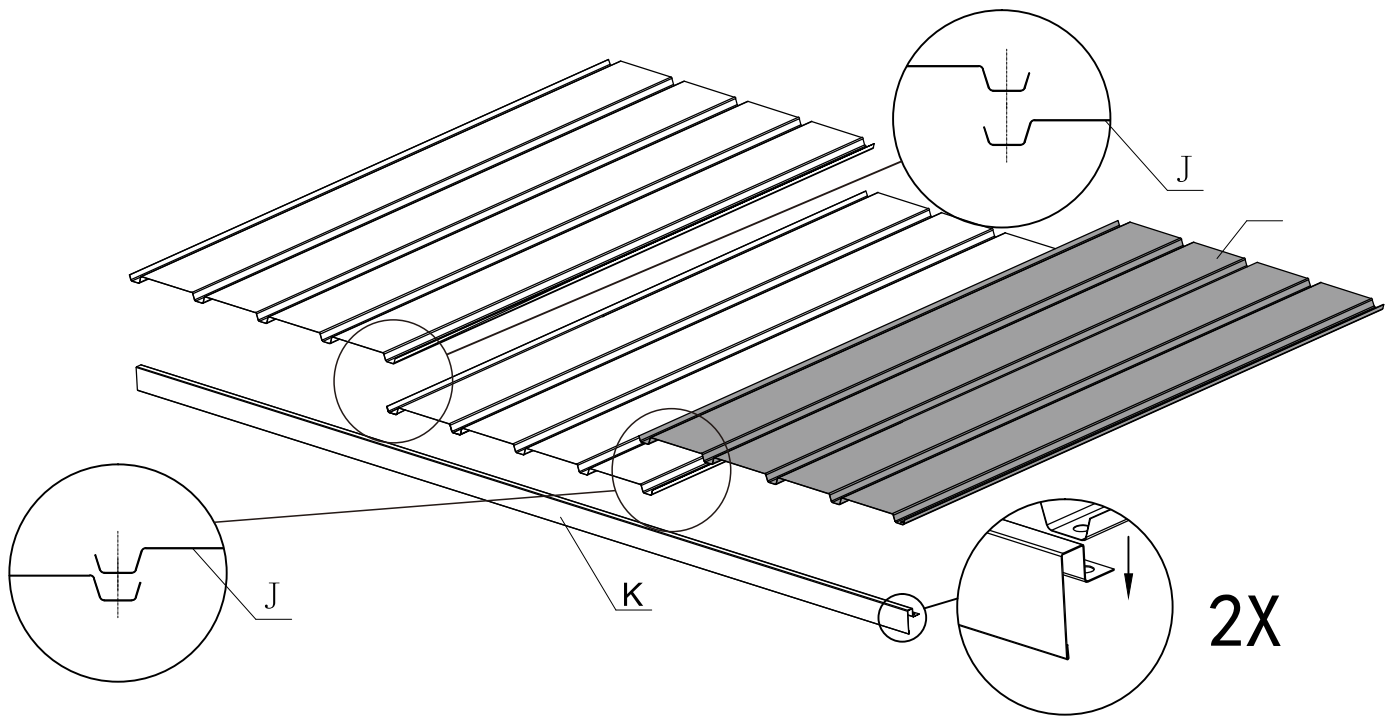
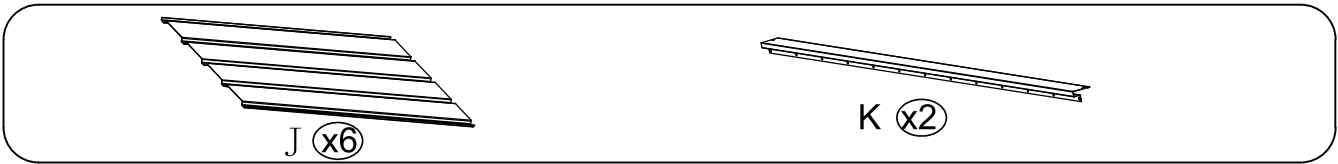

2X

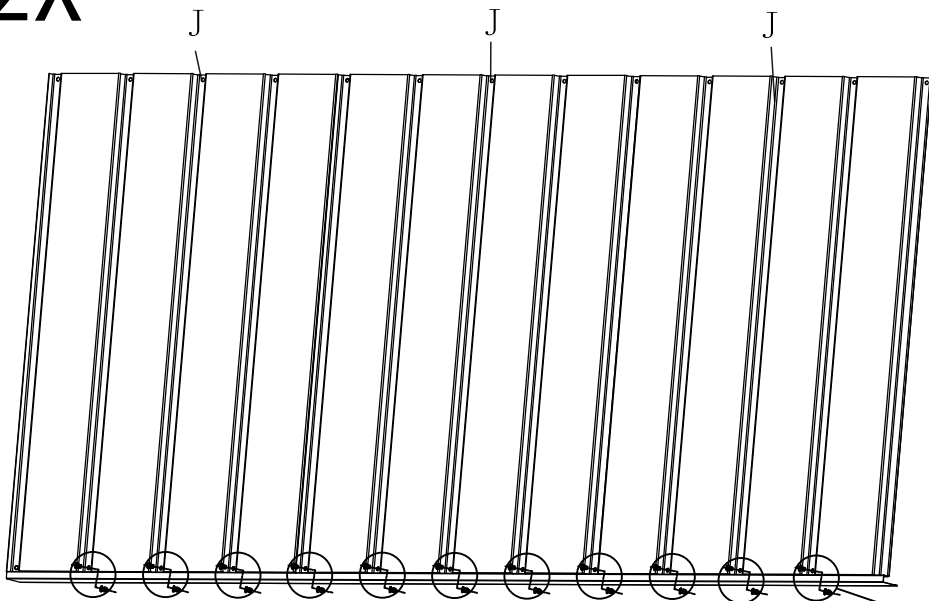

Place 3 roof panel #J ON the finishing bar and secure with 11 bolts #6, gaskets and nuts.

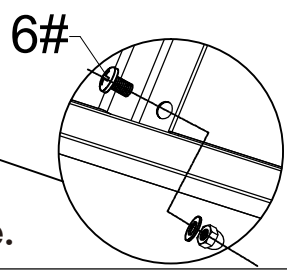

Repeat the above procedures to assemble another side.



R (x2)

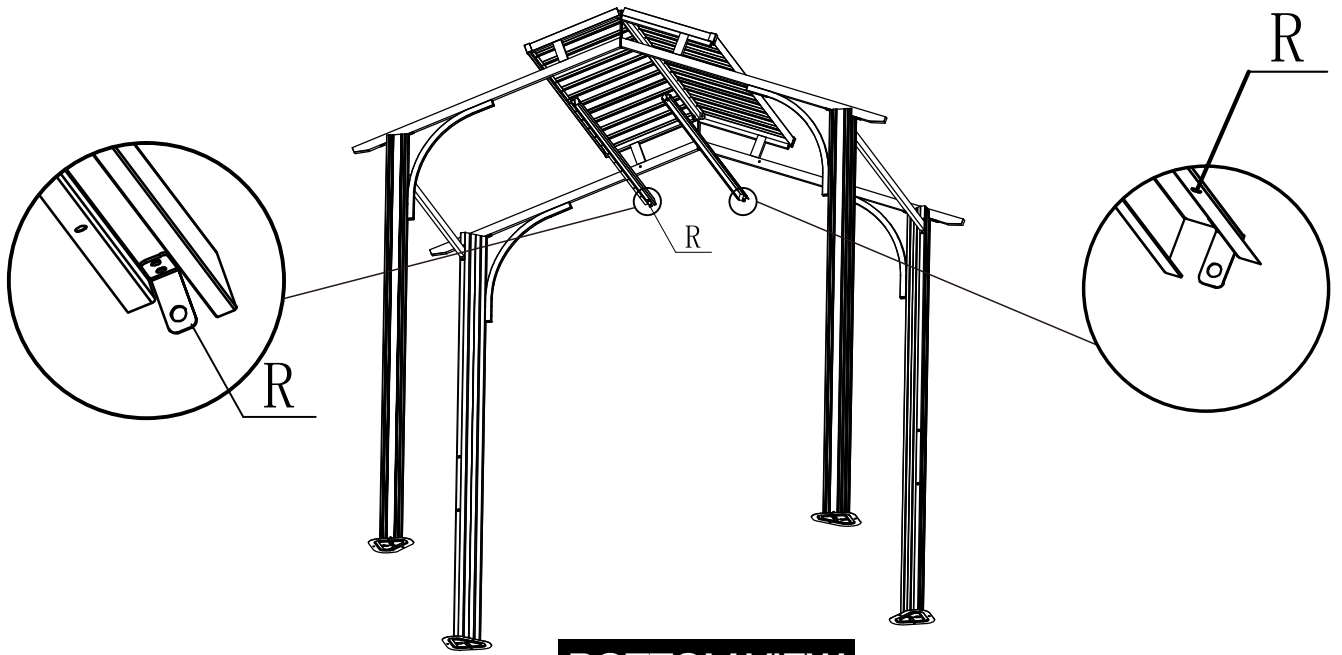

BOTTOM VIEW



M6 × 16

1# (x4)



11# (x1)

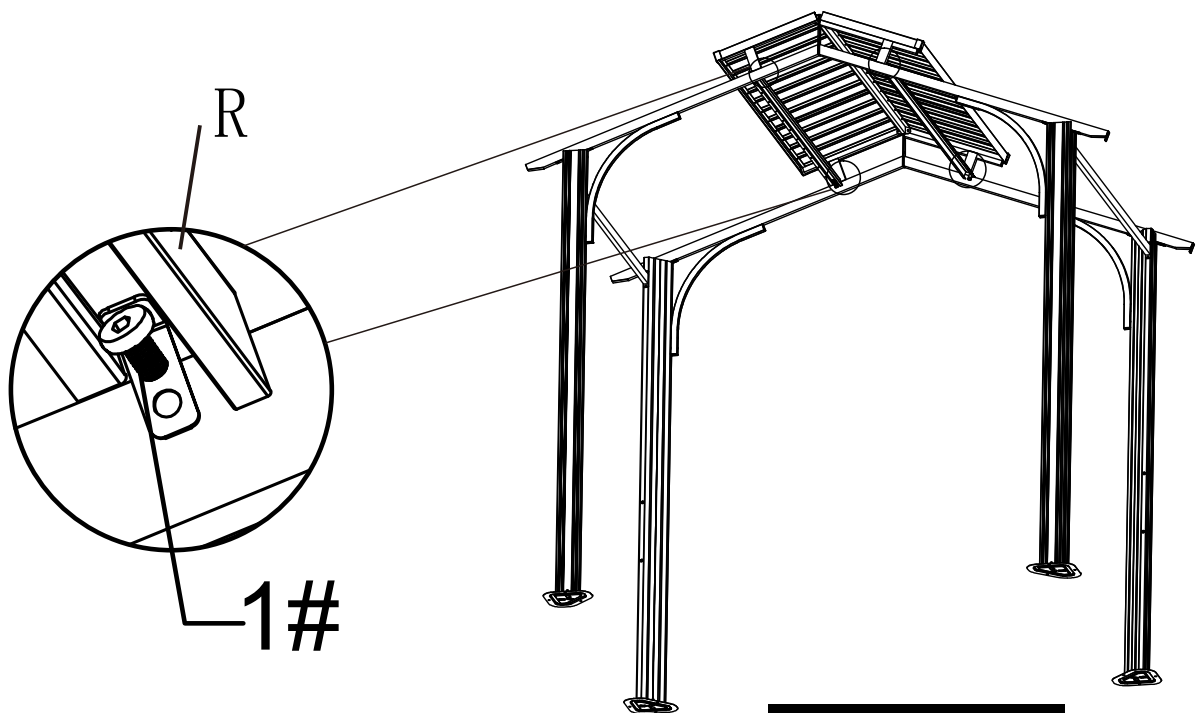

BOTTOM VIEW

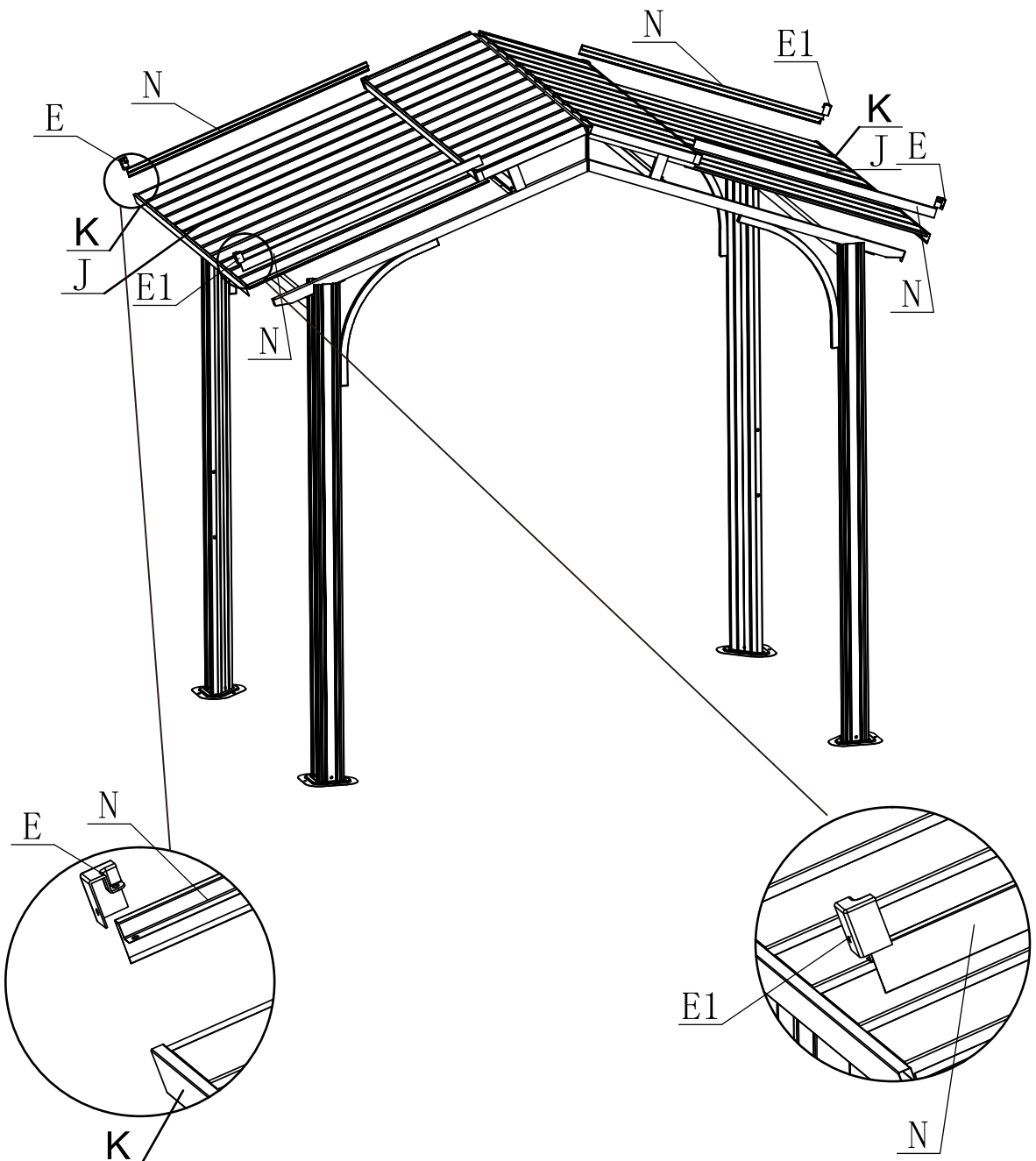
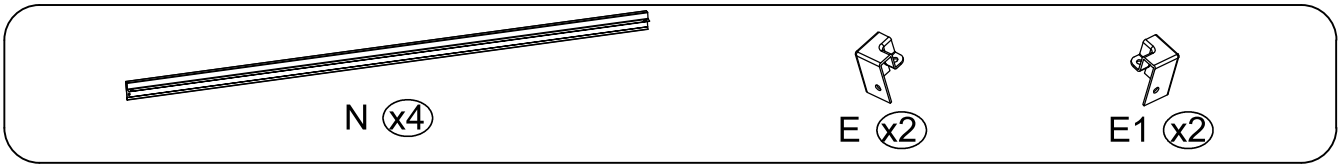

EXPLODED VIEW



M4x8
6# (x22)



ST4x10
9# (x12)

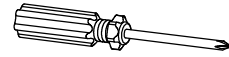

14# (x1)

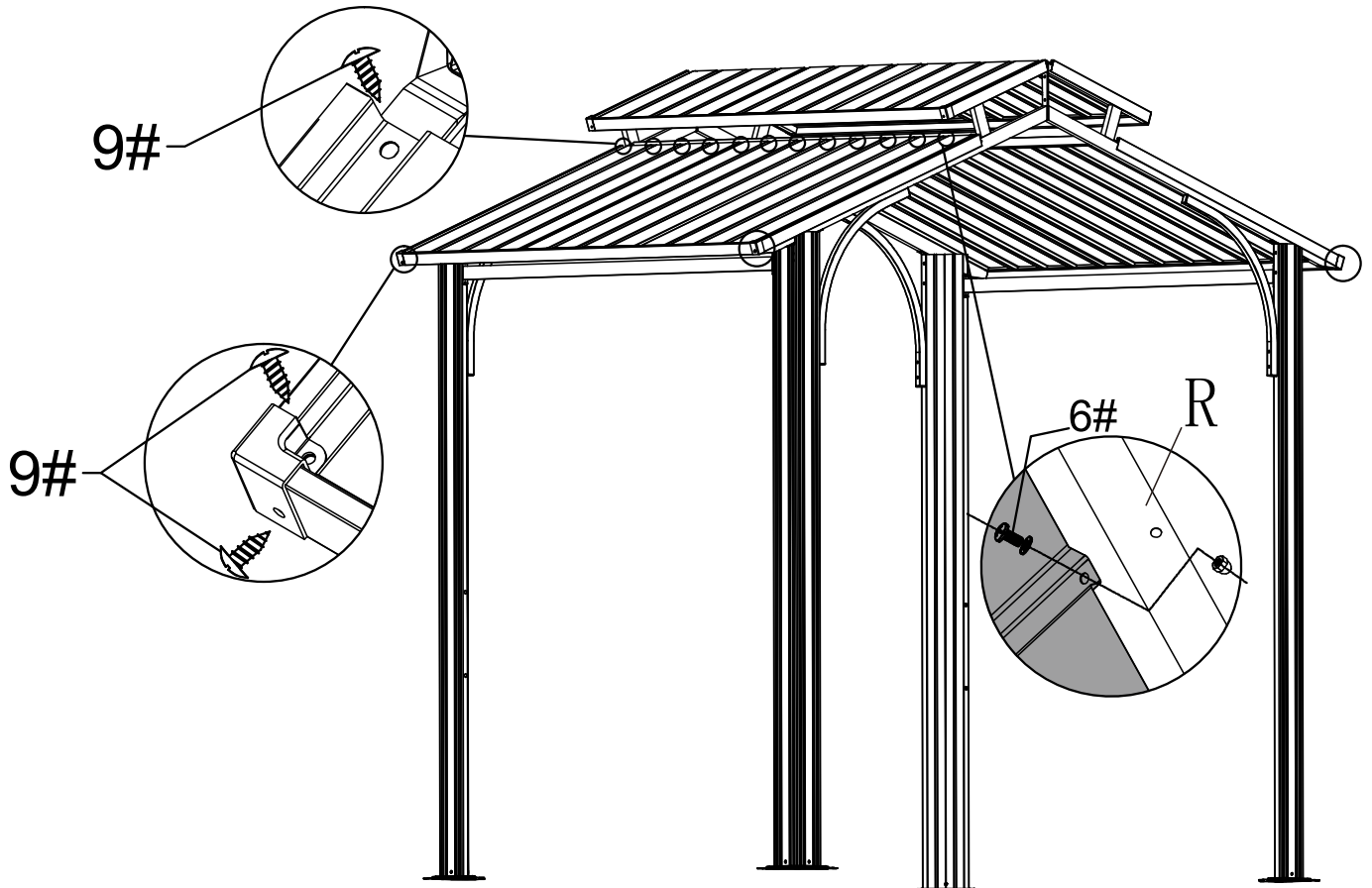

Step1: Use 11 bolts #6,gaskets and nuts to fix roof panel to the solidifying bar #R.

Step2: Use 1 self-tapping bolt #9 to fix part #N to the roof tube.
Repeat the above procedure to the other 3 sides.

Step3: Use 2 self-tapping bolts #9 and fixing end #E to fix part #K and #N , Use 2 bolt #9 and fixing bracket #E1 to fix part #K and #N .
Repeat the above procedures to assemble the opposite side.

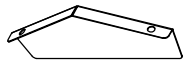

L (x2)

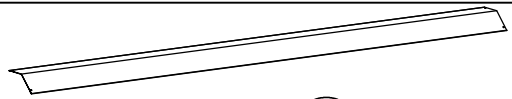

S (x1)

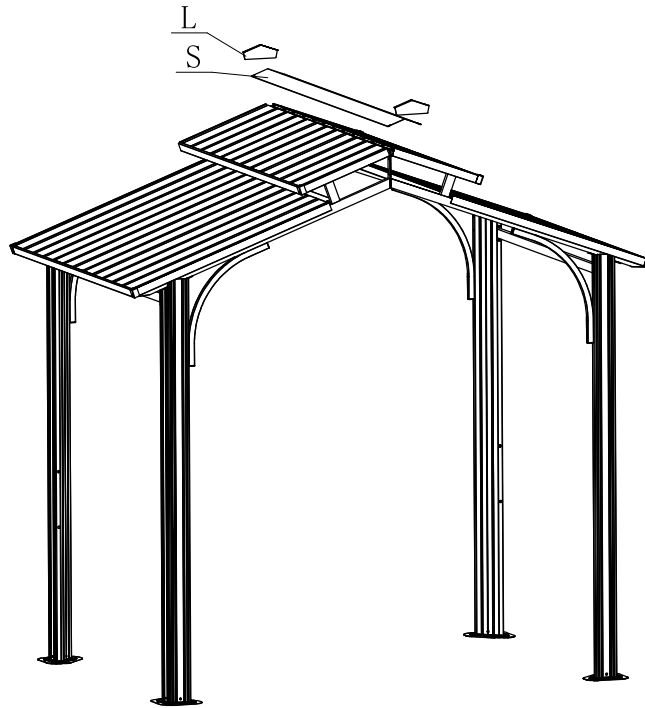

ST4 x 10
9# (x4)



D4 H2
10# (x4)

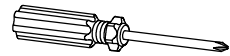

14# (x1)

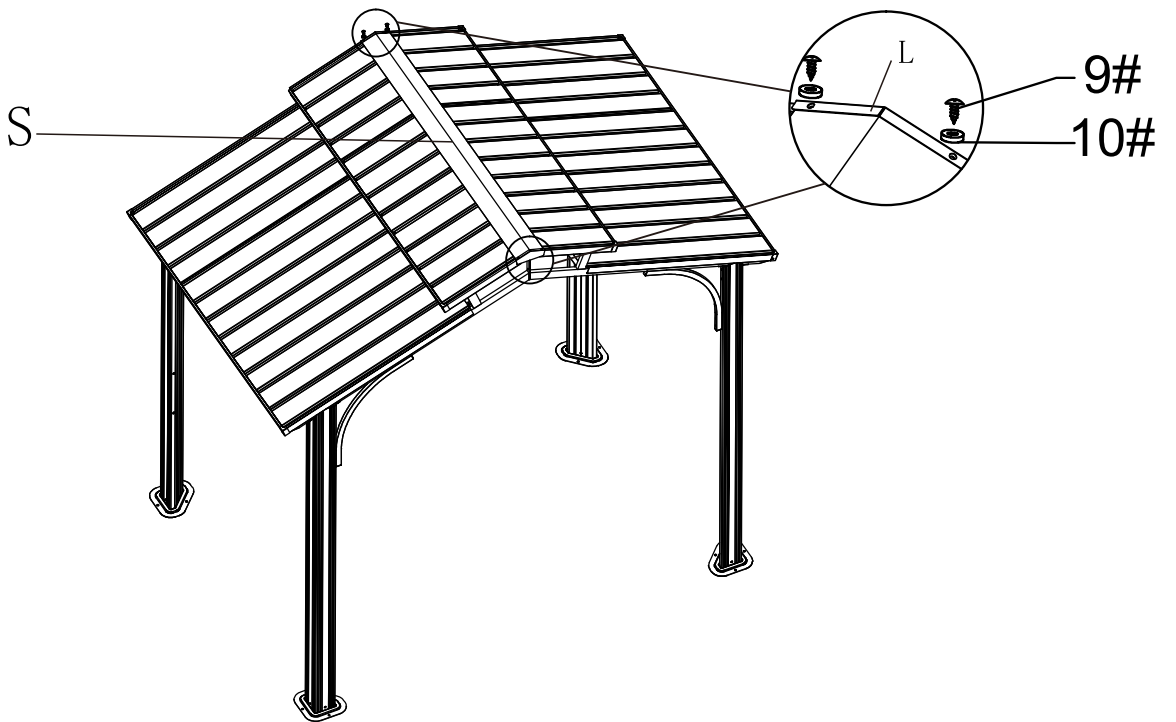
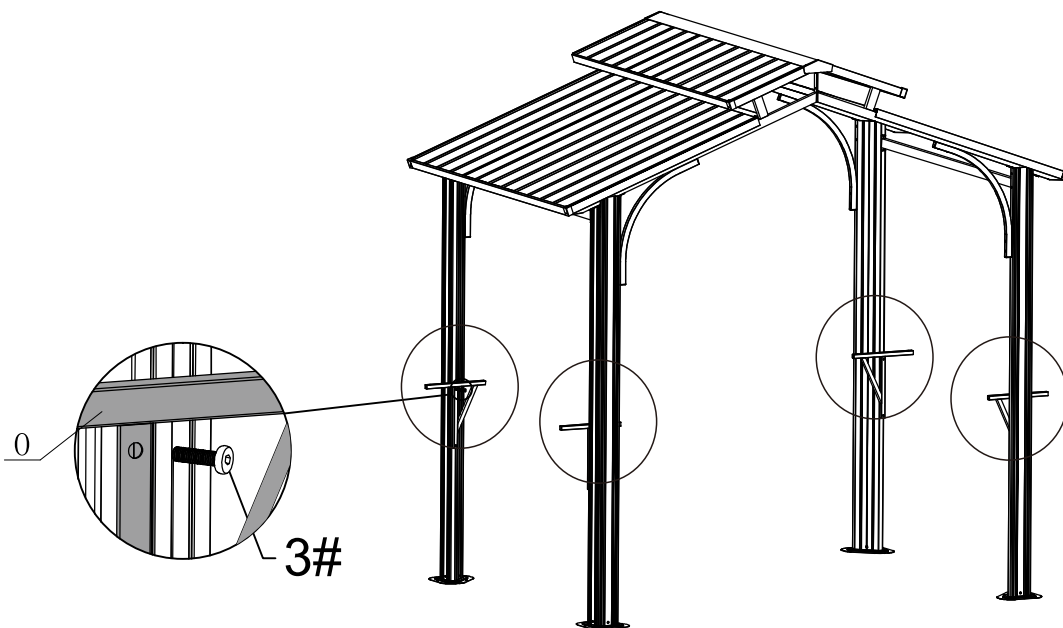
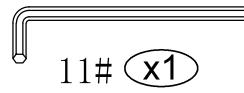
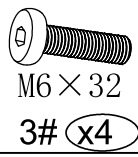
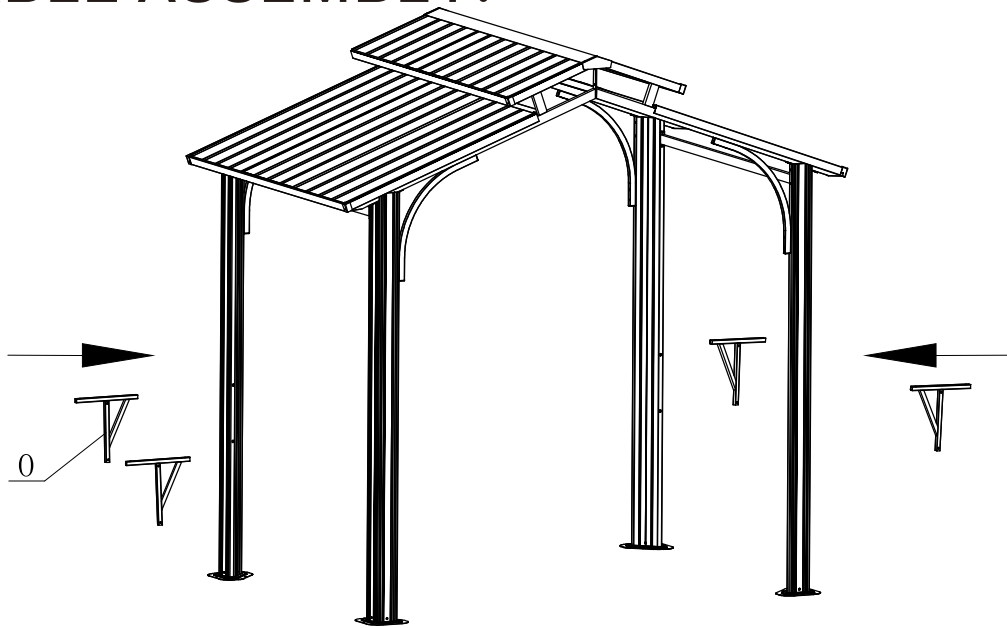
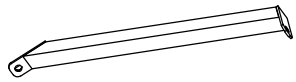



TABLE ASSEMBLY:





P (x4)



M6 x 32

3# (x4)



11# (x1)

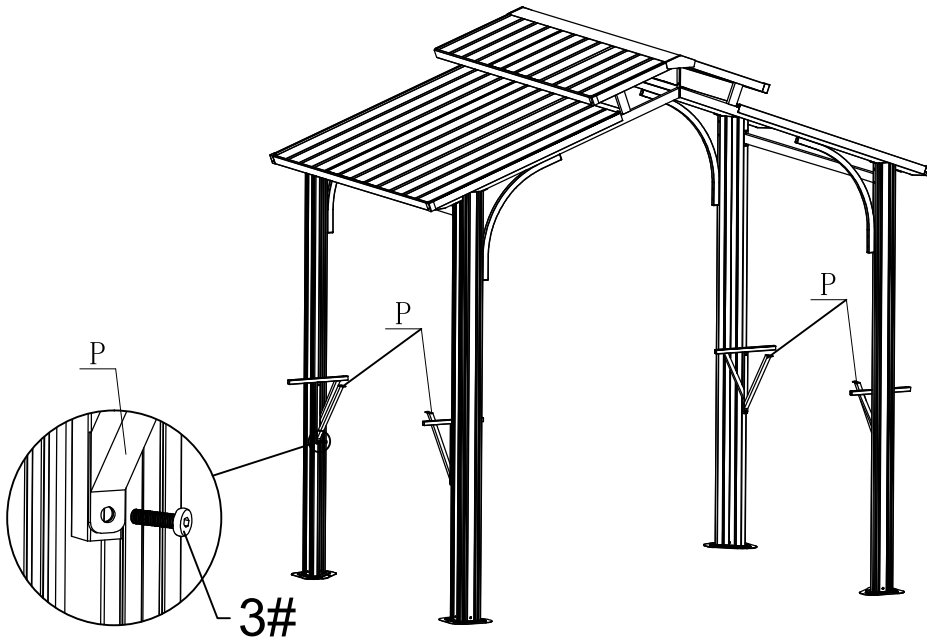

Q (x2)

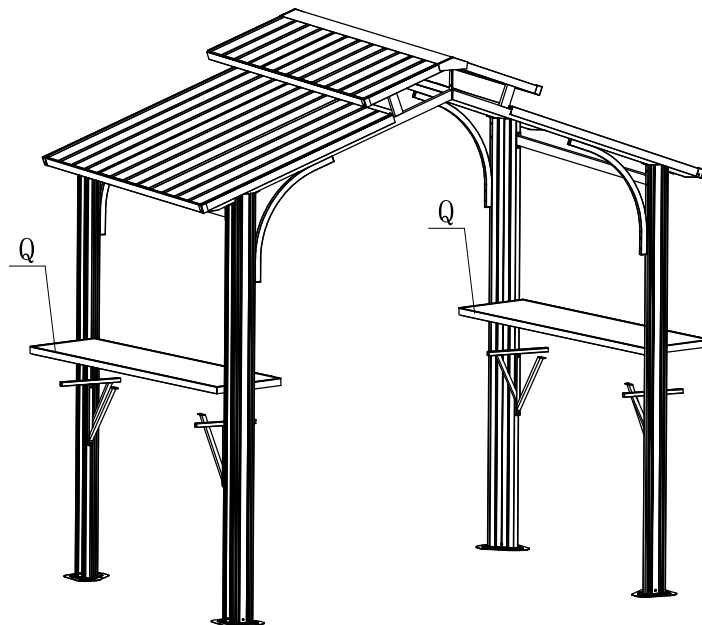

M6 × 16
1# (x4)

M6 × 32
3# (x8)

11# (x1)

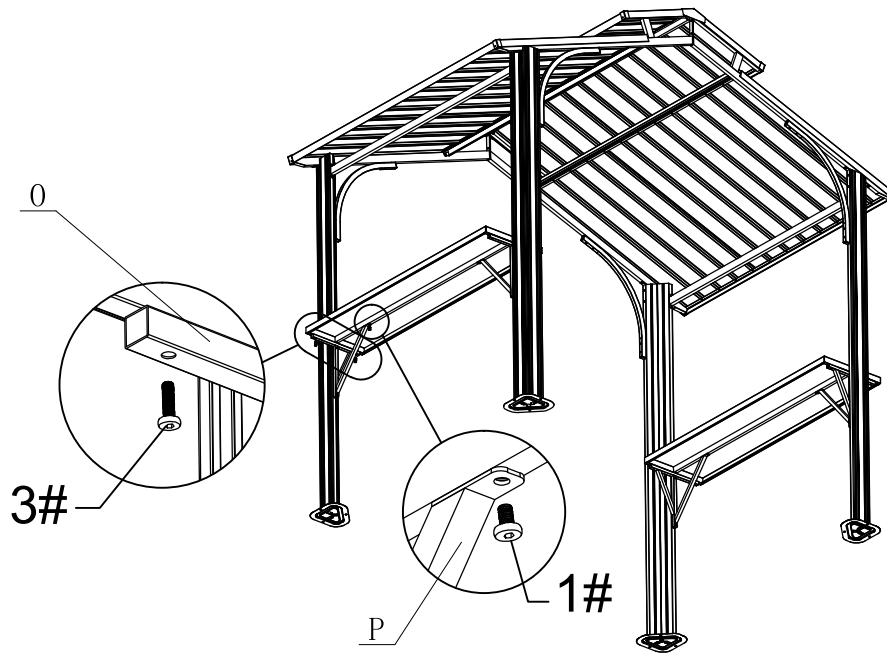

Use 2 bolts #3 to fix part #Q with #O;
Use 1 bolt #1 to fix part #Q with #P.

Repeat the above procedures to assemble the other 3 sides.

BOTTOM VIEW

M6 × 16
1# (x2)

U (x1)

11# (x1)

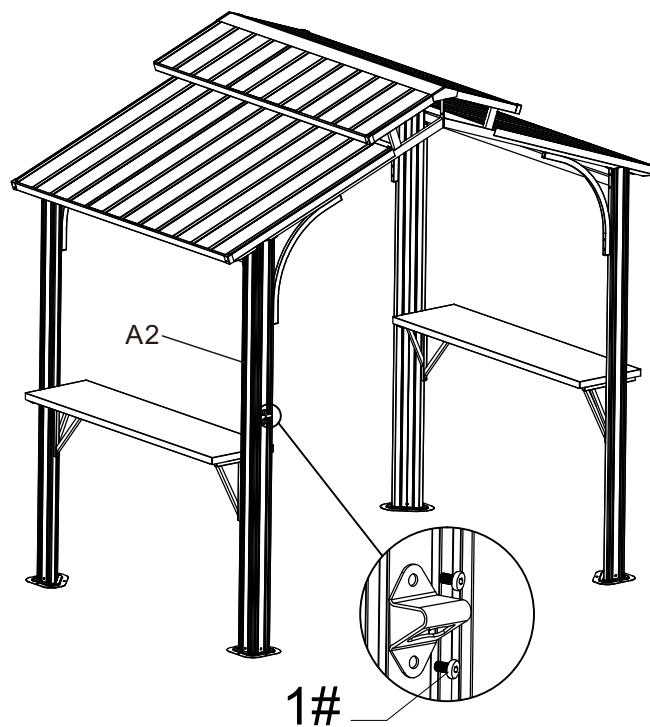



15# (x8)

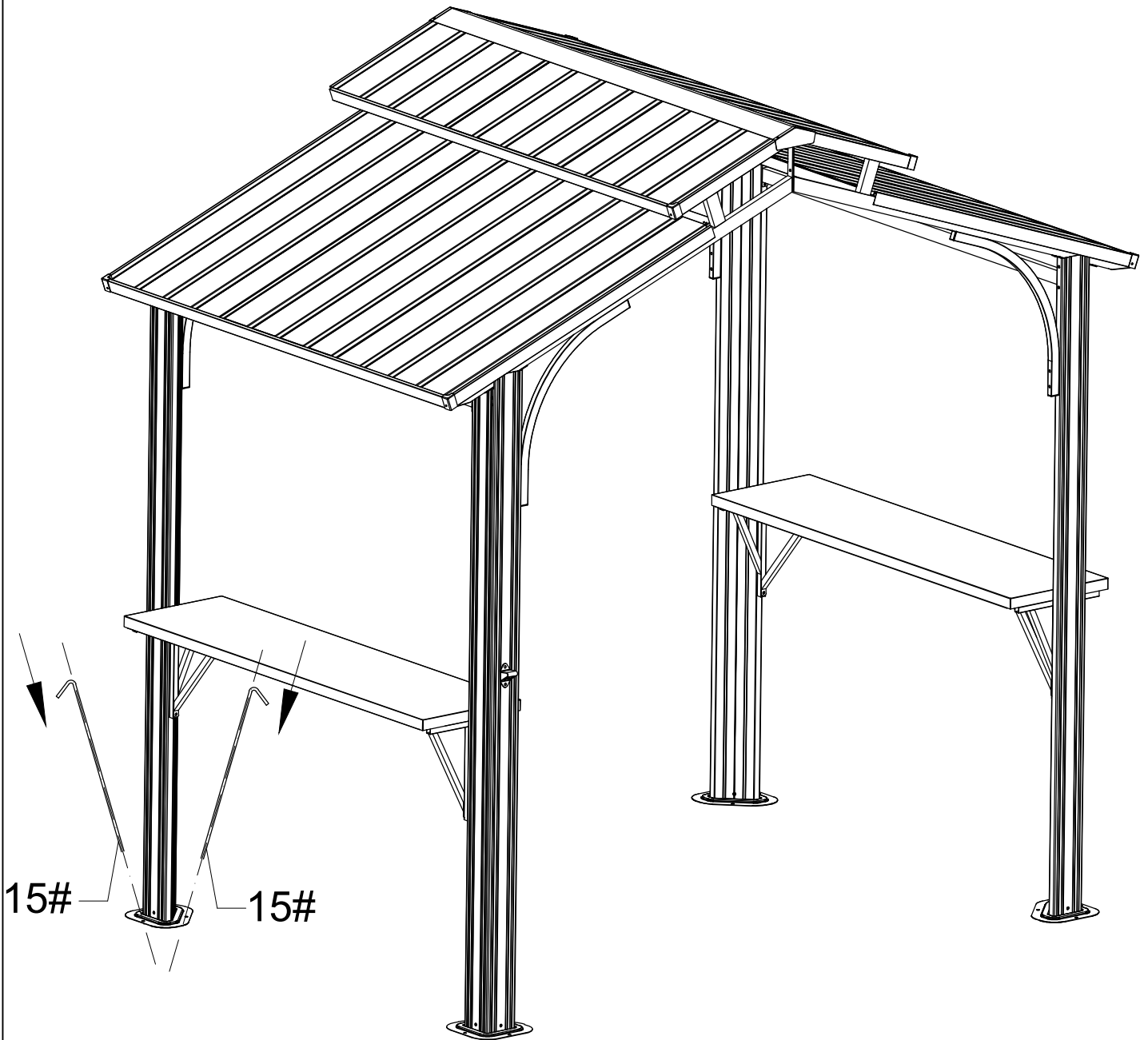

You can secure each base with 2 Post anchor to the soft ground as a temporary use.

⚠ The anchor can not be used as expansion bolts which can stand against the strong wind.



Thanks for your purchase.

At domi outdoor living, we believe in our products.

That's why we provide a 12-month warranty and

friendly, easy-to-reach after-sales service. So if you

have any questions about our product and assembly-

,please feel free to contact us. We will be here for you.

Support:  

After-sales contact email:

service@domioutdoorliving.com

Business cooperation contact email:

marketing@domioutdoorliving.com

Please tell us your order ID when contact.

Attach photos of damaged part for instant reply.