

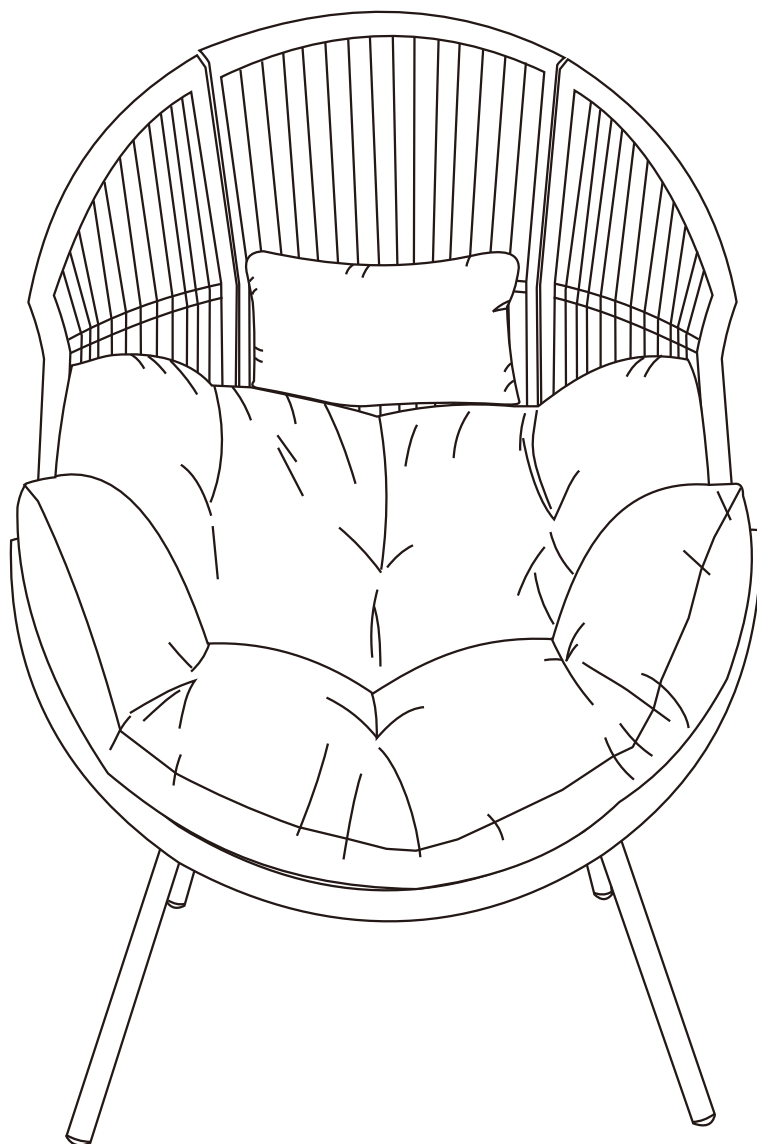











Installation & Assembly

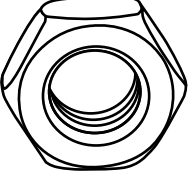
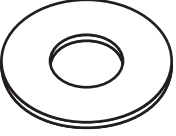
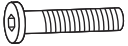
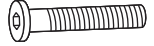

* Don't fully tighten all the bolts till the very end!

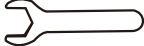
PRE-ASSEMBLY PREPARATION:

- Please read through the instructions before beginning assembly.
- Clear out the space for assembly and lay out all of the parts based on the Parts List, extra room will allow you to easily determine if all the pieces are present.
- Keep small parts and pieces away from children until fully assembled.

Part No.	Part	Qty	Image	Part No.	Part	Qty	Image
A	Right Leg	1		B	Left Leg	1	
C	Seat Panel	1		D	Right Back Panel	1	
E	Middle Back Panel	1		F	Left Back Panel	1	
G	Nut	10		H	Washer	28	
I	Bolt	6	 6*55mm	J	Long Bolt	4	 6*62mm
K	Short Bolt	8	 6*35mm	L	Wrench	1	
M	Open Wrench	1		N	Head Pillow	1	
O	Seat Cushion	2		P	Ratchet wrench	1	



Turn the ratchet wrench left or right to tighten or loosen the screw.

STEP 1

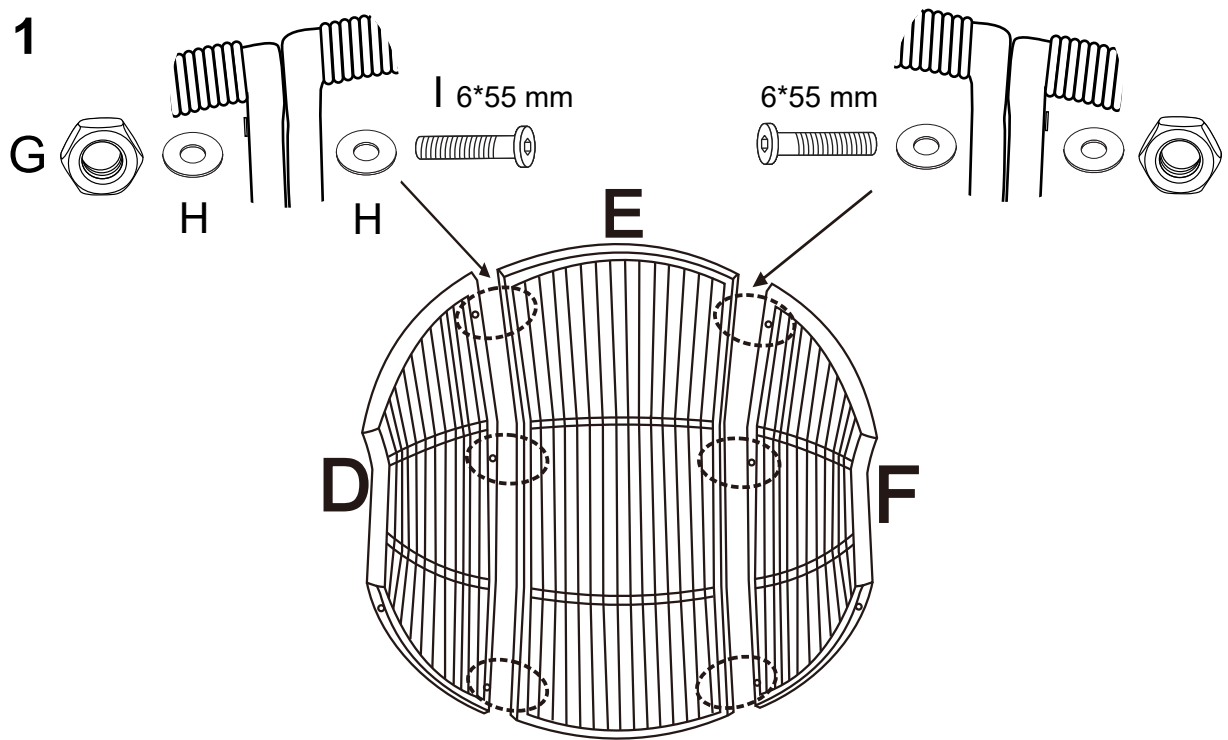

Connect right back panel(Part D) and middle back panel(Part E) with I,H and G.

Don't Tighten Bolts !

Connect left back panel (Part F) in the same way.

STEP 2

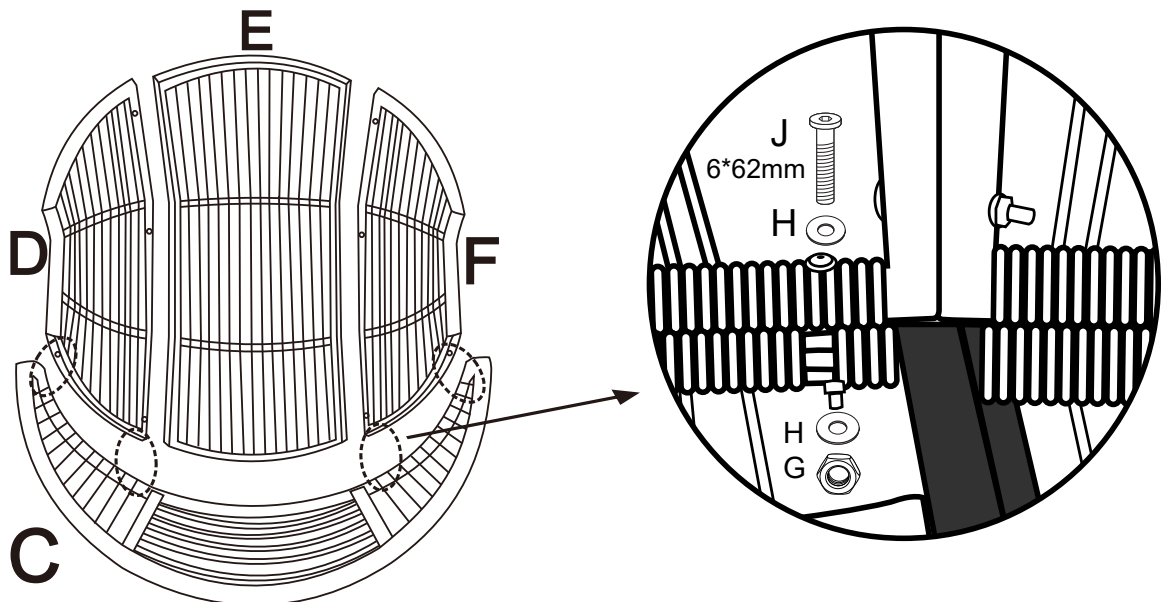

Buckle the back parts upside down on the floor.

Connect back panels and seat with J (6*62mm),H and G.

Tighten all the bolts !

STEP 3

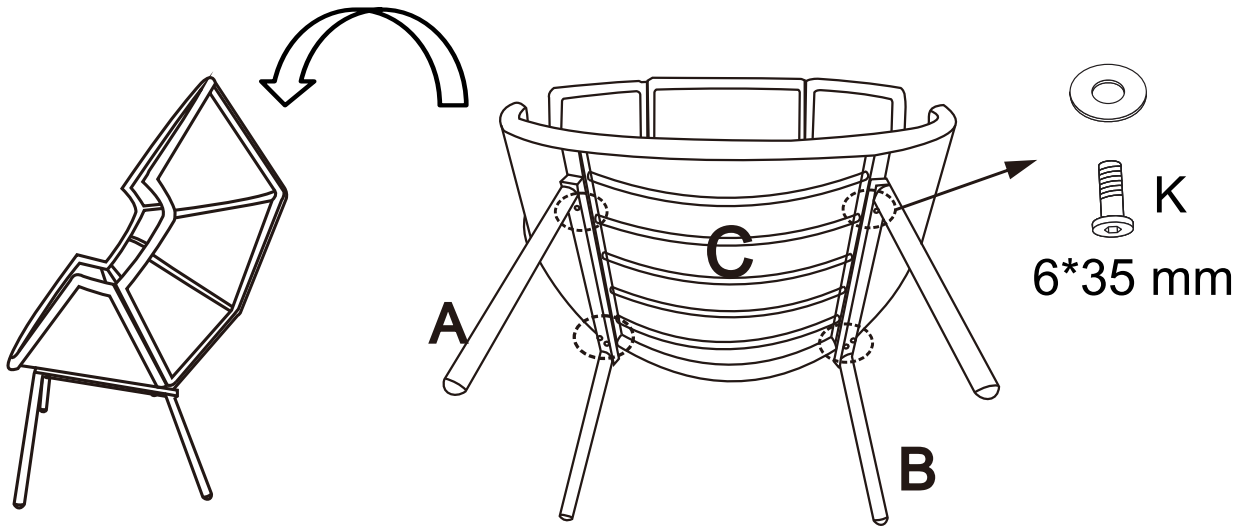

Connect legs and seat with bolts and washers.

Tighten all the bolts !

STEP 4

Fasten the ties

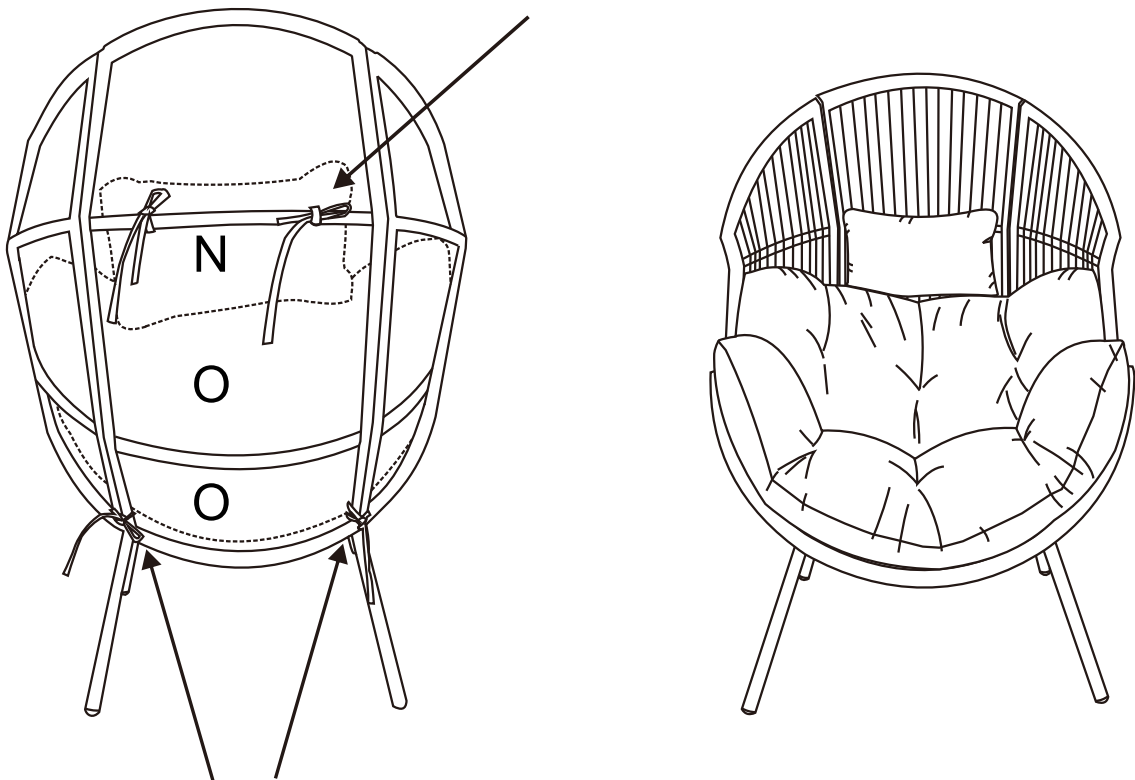

Both seat cushions are tied here.