

ASSEMBLY INSTRUCTIONS

MODEL: 3466-25 ELEANOR ROUND TABLE (NATURAL)

Please read instructions carefully

Remove all wrapping materials, staples and packing straps from the carton.







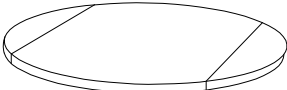

Refer to Parts List and Hardware List and ensure they are complete before you start assembling.

Place all wooden parts on a clean, flat and soft surface (e.g carpet or rug) to prevent parts from being scratched.

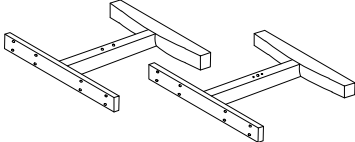
CAUTIONS: 1) DO NOT FULLY TIGHTEN BOLTS AND NUTS UNTIL ALL PARTS HAVE BEEN ASSEMBLED.

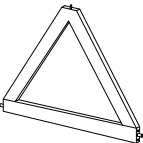
2) DO NOT OVER-TIGHTEN BOLTS AND NUTS .

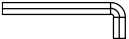
3) KEEP ALL HARDWARE PARTS OUT OF REACH OF CHILDREN.

Designation	Part	Qty	Part List	Hardware	Qty	Hardware List
TABLE TOP	P1	1PC		H1	4PCS	BOLT Ø1/4" x 70mm 
TABLE LEGS	P2	2PCS		H2	16PCS	BOLT Ø5/16" x 38mm 
				H3	16PCS	SPRING WASHER Ø5/16" x 13mm 
STRETCHER	P3	1PC		H4	16PCS	FLAT WASHER Ø5/16" x 19mm 
				H5	1PC	ALLEN KEY M4 x 59mm 
LEG ACCENT	P4	2PCS				

COMPLETE ASSEMBLY

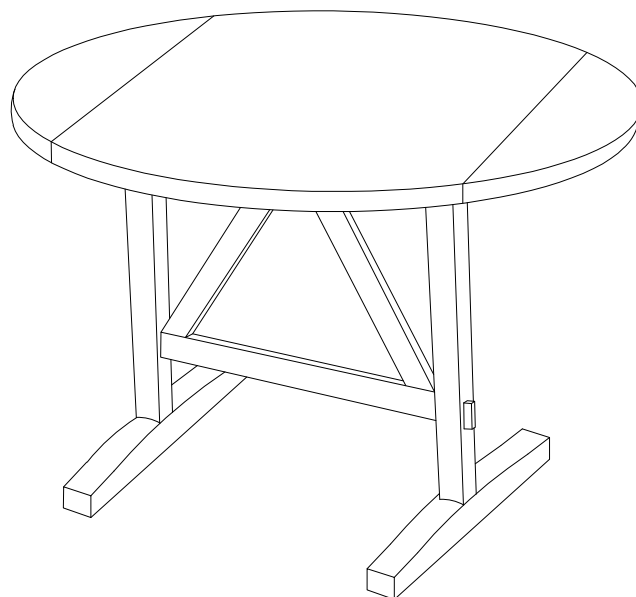

ASSEMBLY INSTRUCTIONS

MODEL: 3466-25 ELEANOR ROUND TABLE (NATURAL)





STEP 1

Prepare the TABLE TOP (P1) by placing it upside-down on a flat, soft & clean surface.
Assemble TABLE LEGS (P2) by attaching it to the connecting blocks in the TABLE TOP.

Align BOLT (H2) fitted with a SPRING WASHER (H3)
& a FLAT WASHER (H4) through the connecting block holes.
Secure the leg on both sides with the bolts.

Tighten all the bolts with ALLEN KEY (H5).

See image below.

(H2) x 8PCS	
(H3) x 8PCS	
(H4) x 8PCS	
(H5)	

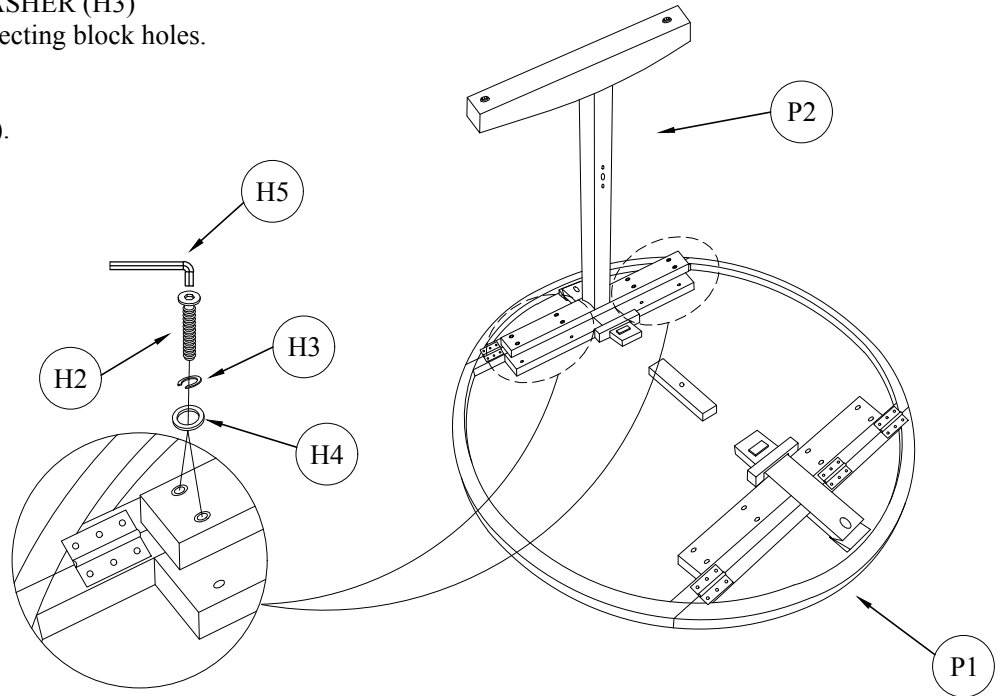

STEP 2

Align the STRETCHER (P3) so that they connect to the TABLE TOP (P1) and TABLE LEGS (P2). Use the wooden peg and connect it with the Legs.

See image below.

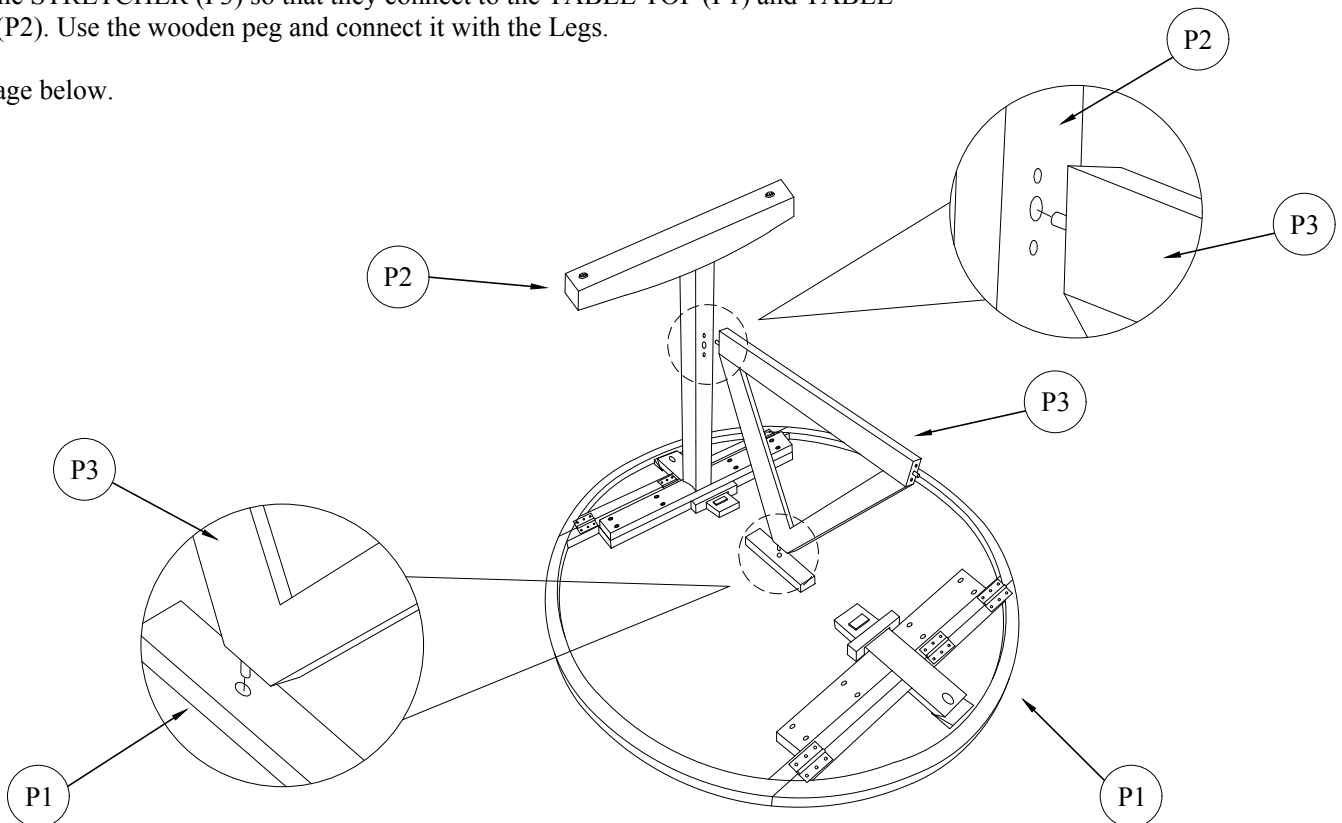

ASSEMBLY INSTRUCTIONS

MODEL: 3466-25 ELEANOR ROUND TABLE (NATURAL)

STEP 3

Repeat STEP 1 by assembling the other set of TABLE LEGS (P2) by first connecting the TABLE STRETCHER (P3) to the other set of legs. You can now proceed to secure the leg on both sides with corresponding bolts.

Tighten all the bolts with ALLEN KEY (H5).

See image below.

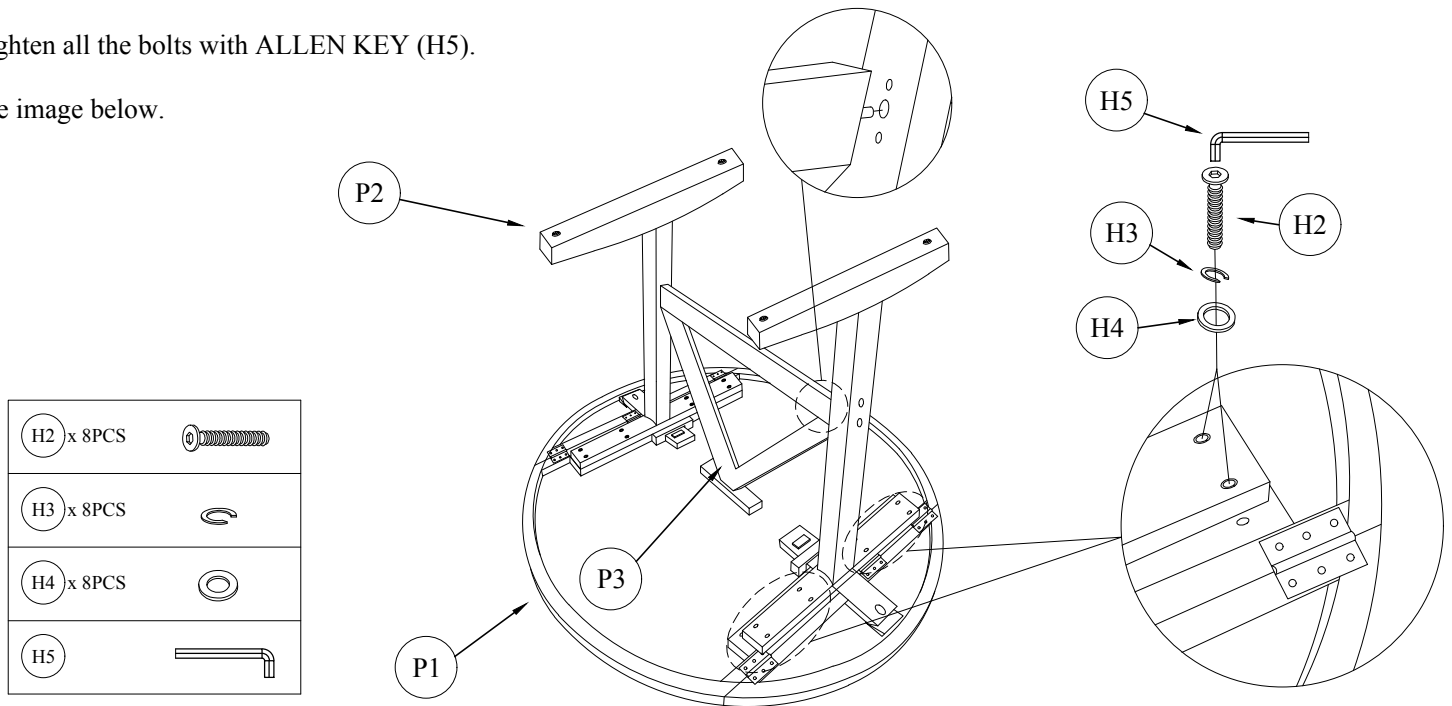

STEP 4

Align the BOLT (H1) through the connecting block holes in the TABLE LEGS (P2). Tighten all bolts with the ALLEN KEY (H5).

See image below.

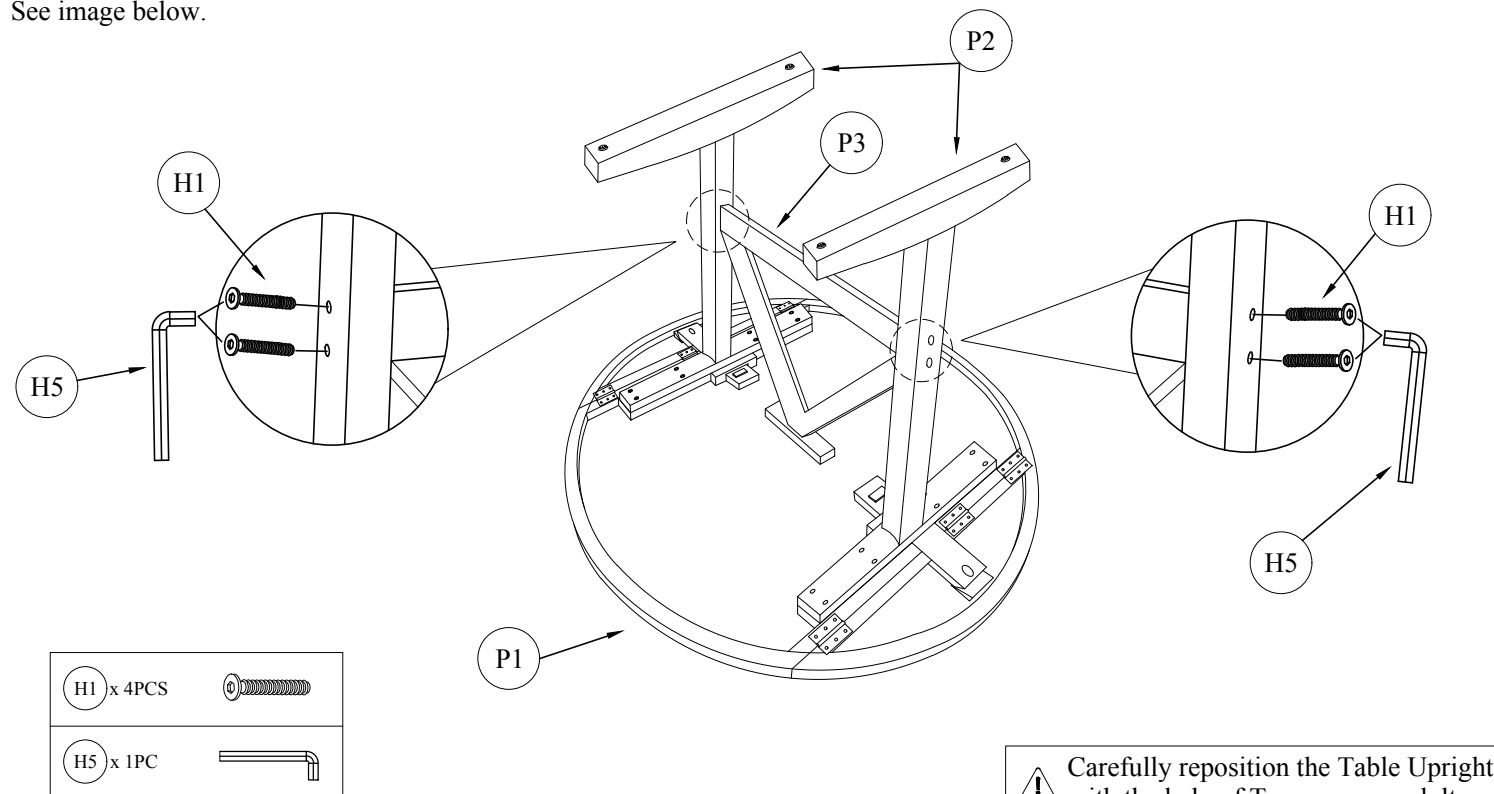

Carefully reposition the Table Upright with the help of Two or more adults.

ASSEMBLY INSTRUCTIONS

MODEL: 3466-25 ELEANOR ROUND TABLE (NATURAL)

STEP 5

Align the LEG ACCENT (P4) through the connecting block holes in the TABLE LEGS (P2).
Secure this part on both legs as shown below.

Adjust the LEVELERS 4 PCS, turn until they are balanced and touching the floor.

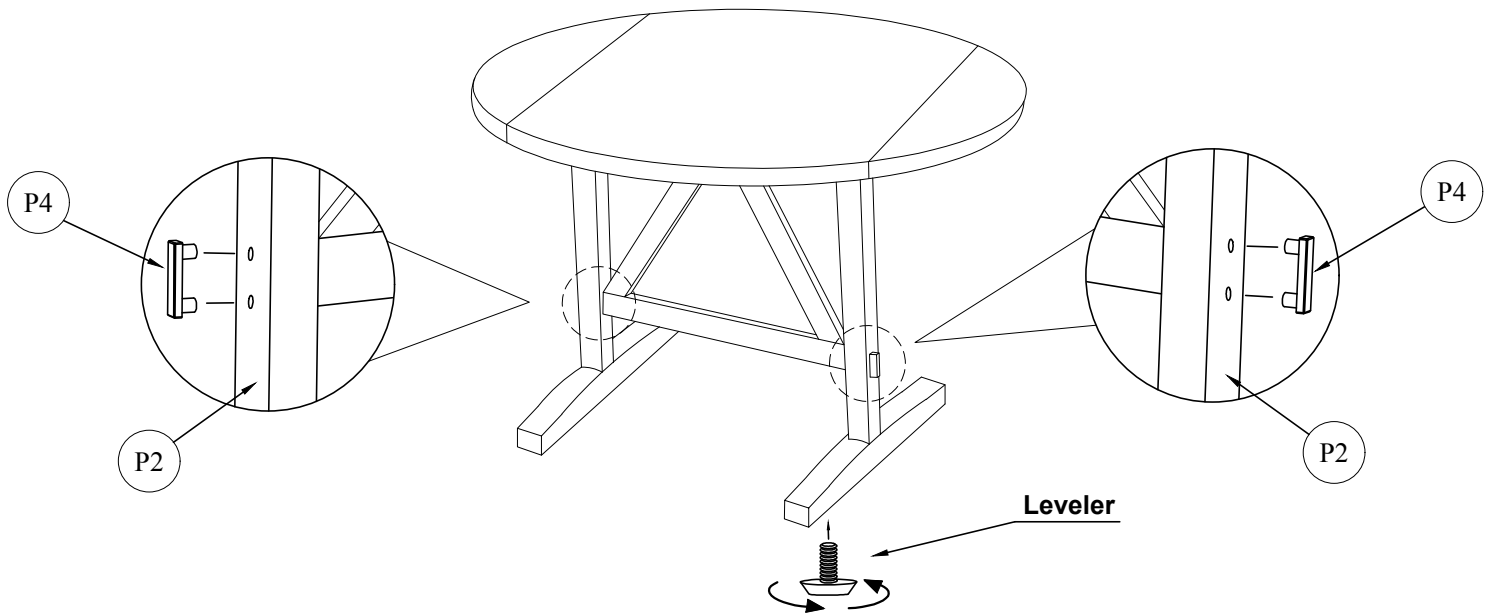

STEP 6

The TABLE TOP CAN BE ADJUSTED to reduce or extend the total table size. To adjust it, you need to pull in or out the wooden bars located underneath each side of the table.

See image below.

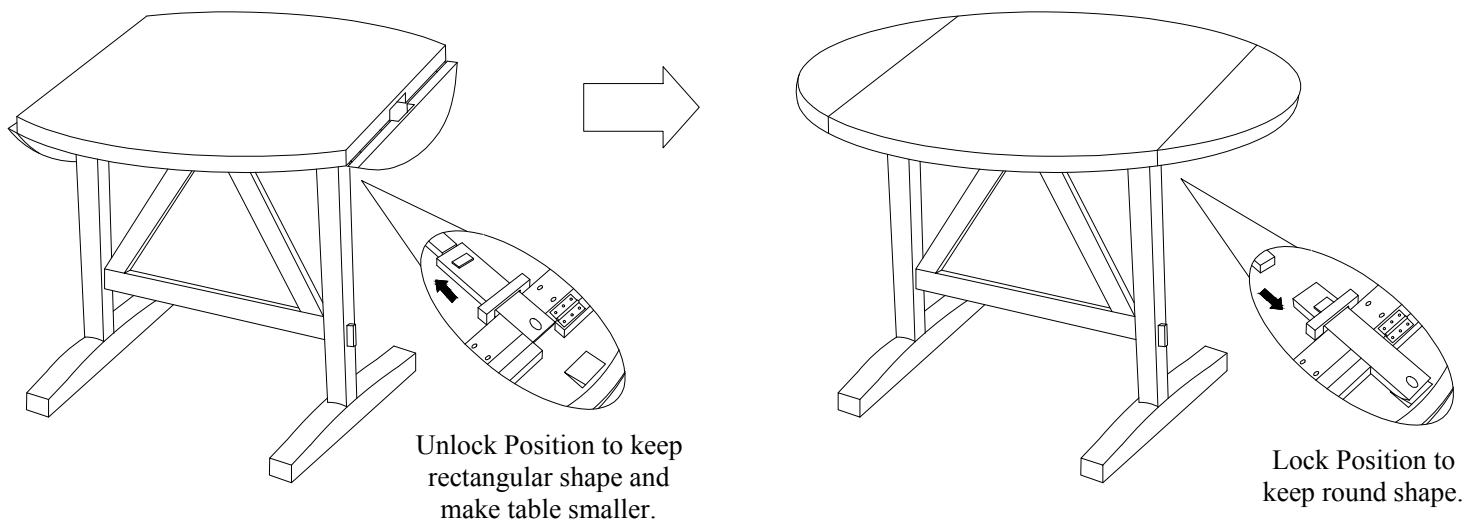

CARE AND MAINTENANCE

SAFETY - To avoid any risk of suffocation to children or animals, dispose off the plastic bags immediately.

CLEANING - Clean with damp cloth and mild detergent. Do not use bleach or abrasive products.

FITTINGS - Tighten bolts and nuts from time to time to ensure all parts of product are securely fitted.