

(D) Montageanleitung

(GB) Assembly instructions

(NL) Handleiding voor de montage

(PL) Instrukcja montażu

(TR) Montaj talimatı

(RU) Инструкция по монтажу

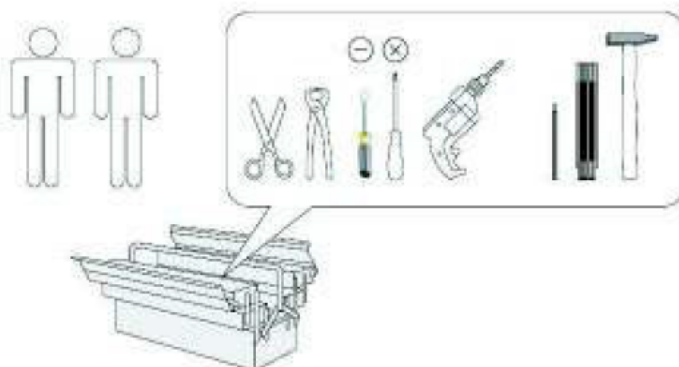

Sicherheitshinweise • Safety instructions • Veiligheidsinstructies •  
Wskazówki bezpieczeństwa • Güvenlik uyarıları ? Правила техники безопасности

<b>D</b>	Das beigegefügte Wandbefestigungsmaterial (Dübel und Schrauben) eignet sich nur für festes Mauerwerk (z.B. Beton- oder Ziegelwände). Für andere Wandaufbauten sind eventuell Spezialdübel und andere Schrauben notwendig. Ziehen Sie gegebenenfalls eine Fachkraft zurate.
<b>GB</b>	The enclosed wall mounting materials (dowels and screws) are only suitable for solid masonry (e. g. concrete or brick walls). Special dowels and other screws may be necessary for other wall constructions. If necessary, please consult a qualified professional.
<b>NL</b>	Het bijgeleverde bevestigingsmateriaal (pluggen en schroeven) is geschikt voor vaste muren (bijv. betonnen of bakstenen muren). Voor andere muurconstructies zijn eventueel speciale pluggen en andere schroeven noodzakelijk. Consulteer eventueel een vakman.
<b>PL</b>	Załączony materiał mocowania w ścianach (kolki oraz śruby) nadaje się wyłącznie do zastosowania w stabilnym murze (np. ściany betonowe lub ceglane). Do montażu ściennych innego rodzaju konieczne są specjalne kolki i inne śruby. W przypadku wątpliwości prosimy zasięgnąć porady fachowca.
<b>TR</b>	Testimat kapsamındaki duvar tipi sabitleme materyali (dübel ve vidalar) sadece beton ve tuğla duvarları gibi sağlam duvar yapıları için uygundur. Başka duvar yapıları için özel dübeller veya başka vidalar gerekli olabilir. Gerekirse bir uzmandan yardım alınız.
<b>RU</b>	Входящий в комплект поставки материал для крепления на стене (дюбели и болты) предназначен только для прочных каменных стен (например, бетонных или кирпичных). Для других типов стен используйте по мере необхо - димости специальные дюбели и другие болты. По мере необходимости обратитесь за помощью к специалистам.

<b>D</b>	Ziehen Sie alle Schrauben sowie tragende Verbindungsteile nach ca. 5 Wochen nach, um eine dauerhafte Standsicherheit zu gewährleisten.
<b>GB</b>	After approx. 5 weeks, tighten all screws and load-bearing connecting parts to ensure permanent stability.
<b>NL</b>	Draai alle schroeven en ook dragende verbindingstukken na ca. 5 weken nog eens vast, zodat een continue stabiliteit wordt gegarandeerd.
<b>PL</b>	Aby zagwarantować trwałą stabilność mocowania należy po ok. 5 tygodniach dokręcić wszystkie śruby oraz elementy łączeniowe.
<b>TR</b>	Tüm vida ve taşıyıcı bağlantı parçalarını kalıcı bir duruş güvenliğini sağlamak için yaklaşık 5 hafta sonra tekrar sıkınız.
<b>RU</b>	Подкрутите все болты, а также несущие соединительные детали прибол, через 5 недель для обеспечения устойчивости в течение длительного времени.

<b>D</b>	Bitte nur mit einem Staubtuch oder leicht feuchtem Lappen reinigen. Keine scheuernden Putzmittel verwenden.
<b>GB</b>	Please only clean with a duster or a damp cloth. Do not use any abrasive cleaners.
<b>NL</b>	Reinig alleen met een stofdoek of een lichtjes vochtige doek. Gebruik geen schurende poetsmiddelen.
<b>PL</b>	Czyszczenie należy wykonać wyłącznie za pomocą ściereczki lub lekko nawilżonego ręcznika. Nie stosować środków czyszczących do szorowania.
<b>TR</b>	Lütfen sadece bir toz bezilye veya hafif nemli yumuşak bir bezle siliniz. Aşındırıcı temizlik malzemeleri kullanmayınız.
<b>RU</b>	Очищайте от пыли тряпкой или слегка влажной ветошью. Не допускается применение чистящих средств, не предназначенных для ухода за мебелью.

<b>D</b>	Das Produkt ist nicht für die Anwendung im Freien geeignet.
<b>GB</b>	The product is not suitable for outdoor use.
<b>NL</b>	Het product is niet geschikt voor het gebruik in open lucht.
<b>PL</b>	Produkt nie jest przystosowany do zastosowań na wolnym powietrzu.
<b>TR</b>	Bu ürün açık havada kullanılmaya uygun değildir.
<b>RU</b>	Изделие не предназначено для использования вне помещений.

<b>D</b>	Überschreiten Sie die angegebenen Maximalbelastungen nicht. Andernfalls kann das Möbelstück beschädigt oder zerstört werden.
<b>GB</b>	Do not exceed the maximum loads specified. Otherwise, the furniture may sustain damage or be irreparably damaged.
<b>NL</b>	Overschrijd de aangegeven maximale belastingen niet. Anders kan het meubelstuk worden beschadigd of vernield.
<b>PL</b>	Nie wolno przekraczać podanych maksymalnych wartości obciążenia. W innym przypadku można mebel uszkodzić lub zniszczyć.
<b>TR</b>	Belirtilen azami yük değerini aşmayınız. aksi takdirde mobilya parçası zarar görebilir veya kullanılamaz hale gelebilir.
<b>RU</b>	Не допускается превышение указанных максимальных нагрузок. В противном случае возможно повреждение или разрушение мебели.

<b>D</b>	Schützen Sie Ihre Möbel generell vor Wasser (z.B. beim Wischen oder Blumen gießen). Die Feuchtigkeit kann in das Möbelstück eindringen und es beschädigen
<b>GB</b>	In general, keep water away from your furniture (e. g. when mopping or watering plants). The moisture may penetrate the furniture and damage it.
<b>NL</b>	Bescherm uw meubelen doorgaans tegen water (bijv. bij het dweilen of als u de bloemen water geeft). De vochtigheid kan in het meubelstuk dringen en het beschadigen.
<b>PL</b>	Mebel należy chronić przed wodą (np. podczas czyszczenia lub podlewania kwiatków). Wilgoć może wnikać w mebel i uszkodzić go.
<b>TR</b>	Genelde mobilyalarınızı sudan koruyunuz (örneğin, yerleri paspaslarken veya çiçekleri sularken). Nem, mobilya parçasına nüfuz edebilir ve zarar verebilir.
<b>RU</b>	Предохраняйте мебель от попадания воды (например, при вытирании или поливке цветов). Не допускайте попадания влаги на мебель, чтобы предотвратить ее повреждение.

<b>D</b>	Der Artikel ist kein Kinderspielzeug! Lassen Sie Kinder auch nicht mit der Verpackung spielen. Sie könnten an der Folie ersticken oder sich an der Umverpackung verletzen.
<b>GB</b>	This product is not a toy! Do not allow children to play with the packaging. They could suffocate in the foil or injure themselves on the packaging.
<b>NL</b>	Het artikel is geen speelgoed voor kinderen! Zorg ervoor dat kinderen ook niet met de verpakking spelen. Ze kunnen stikken door de folie of zich verwonden aan de verpakking.
<b>PL</b>	Produkt nie służy do zabawy! Dzieci nie powinny bawić się opakowaniem produktu, gdyż mogą się udusić folią lub skaleczyć opakowaniem.
<b>TR</b>	Bu ürün bir çocuk oyuncakı değildir! Çocukların ürün ambalajlarıyla oynamalarına asla müsaade etmeyiniz. Çocuklar, folyo nedeniyle boğulabilir veya ambalaj nedeniyle yaralanabilirler.
<b>RU</b>	Не допускается игра детей с изделием! Не разрешайте детям играть с упаковочным материалом. Дети могут задохнуться в упаковочной пленке или пораниться упаковочным материалом.

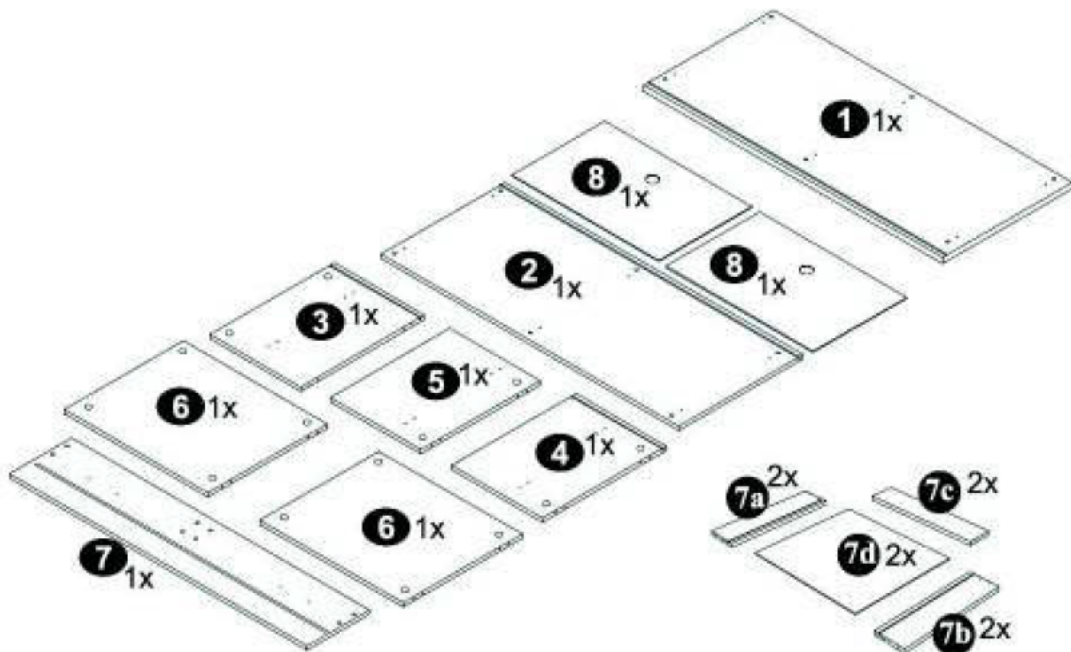

**NR 1**

- B1**  $\phi 8$  x28
- M1** x14
- T1** x10
- C2** x14
- F1** x3
- S5** 3x20 x13

**NR 2**

- U34** L=148/128 x2
- P7** 4x30 x4
- B3**  $\phi 1,4 \times 25$  x10
- L1** 16g x2
- C4**  $\phi 40$  x2

**NR 3**

- R23** L=400 x2L/2R (2kol.)
- S3** 3,5x13 x12
- E2** 5x5 ES x12

**NR 4**

- S5** 1,5x16 x10
- K1** 7 x 50 x14
- G2** x1
- T11** x2

**NR 5**

- F12** x5

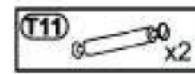
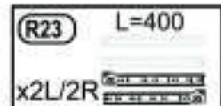
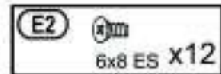
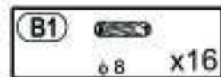
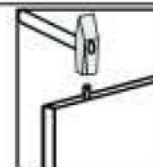
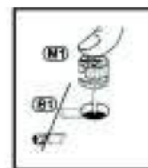
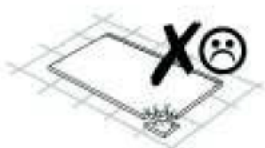
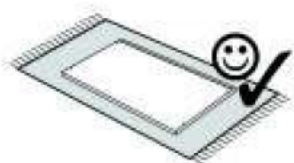



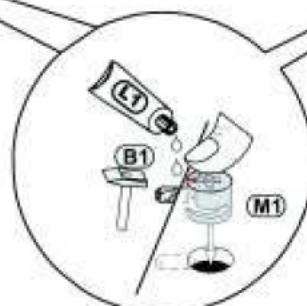
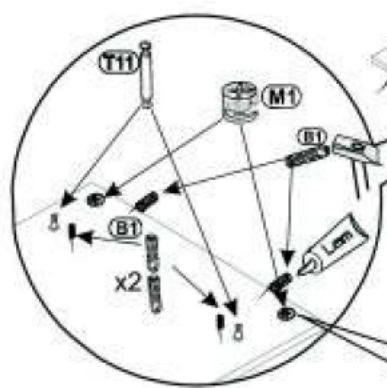
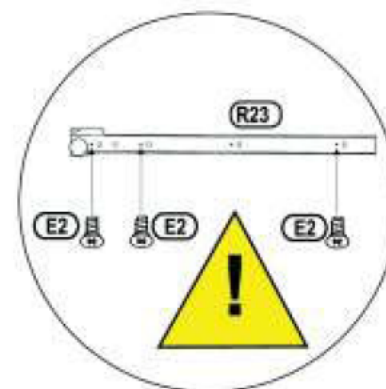
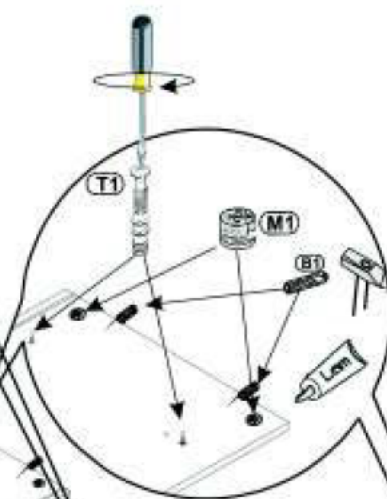
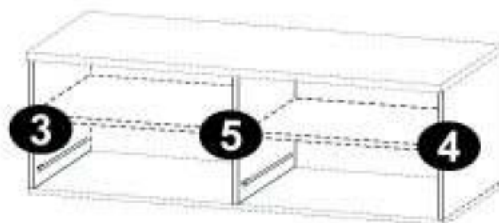

1

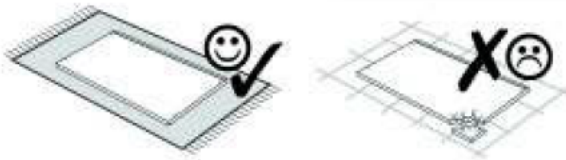

- L1  x1
- D Leim
- GB Glue
- NL Lijm
- PL Klej
- TR Tutkal
- RU Клей



**2**

- T1**  x6
- L1**  16g x1
- M1**  x8
- B1**  ±8 x4

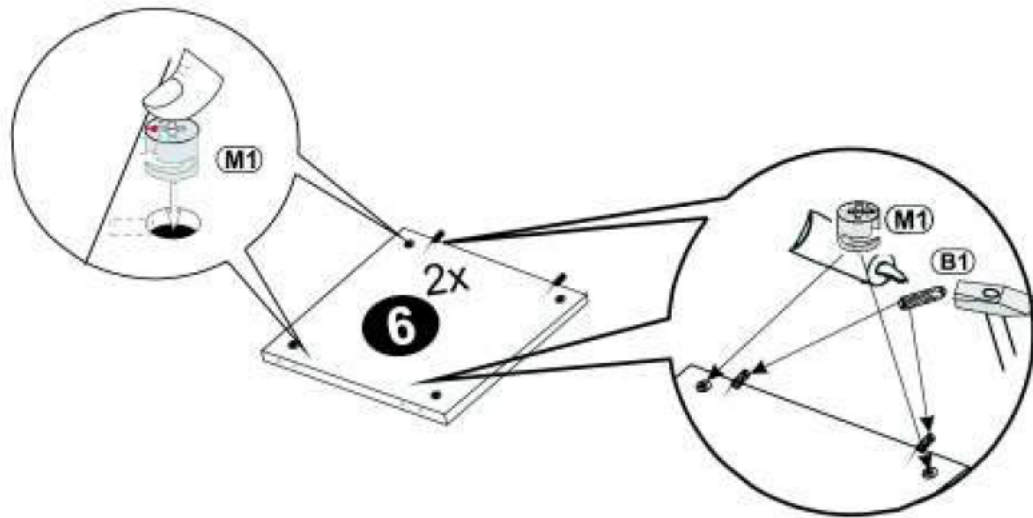
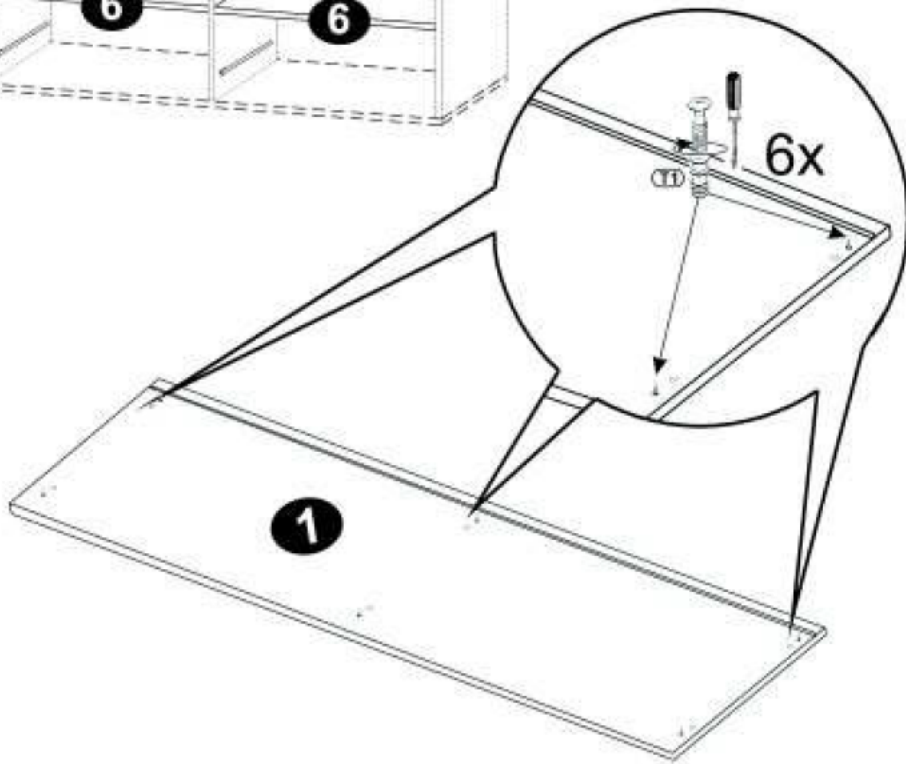
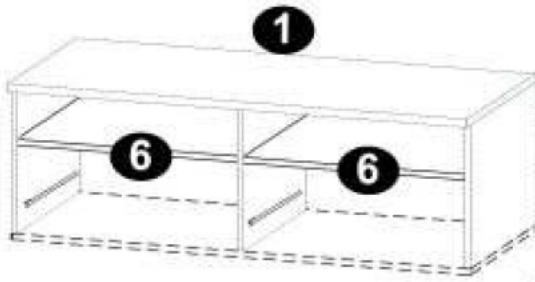



3

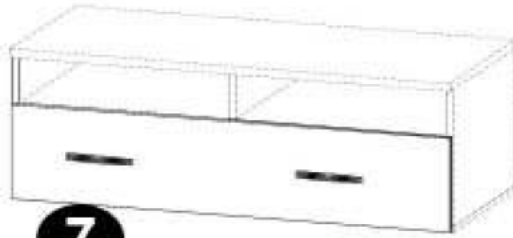

7

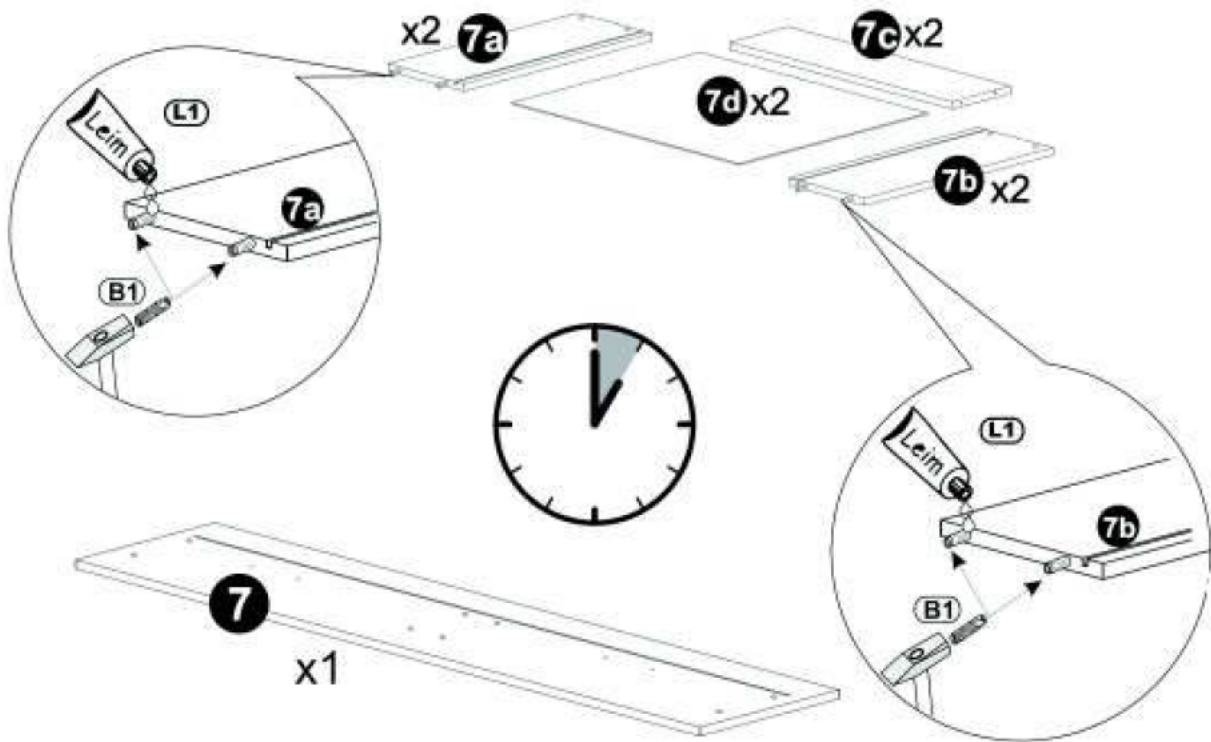
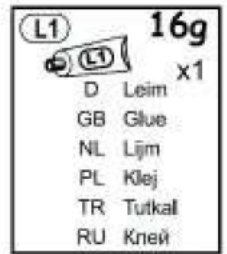
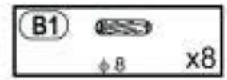

4

x2

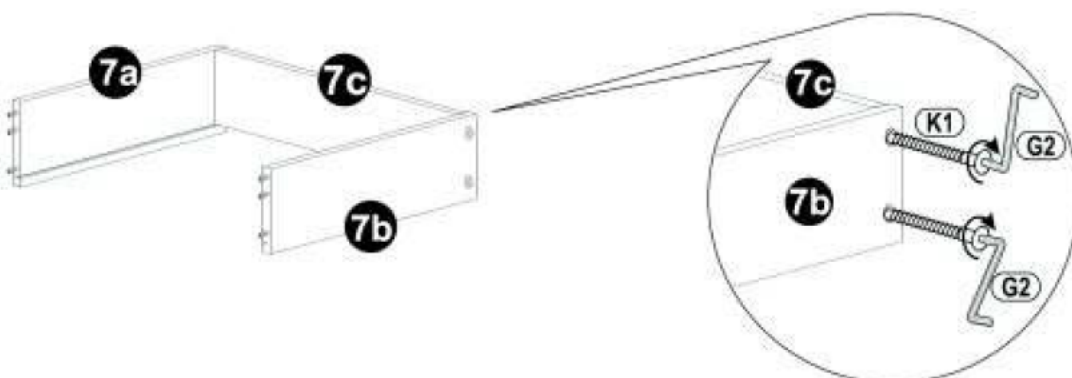
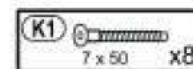

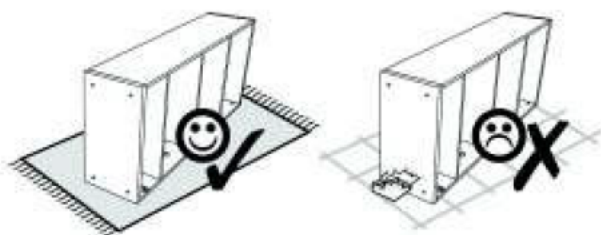

5

<b>L1</b>	<b>16g</b>
	x2
D	Leim
GB	Glue
NL	Lijm
PL	Klej
TR	Tutkal
RU	Клей

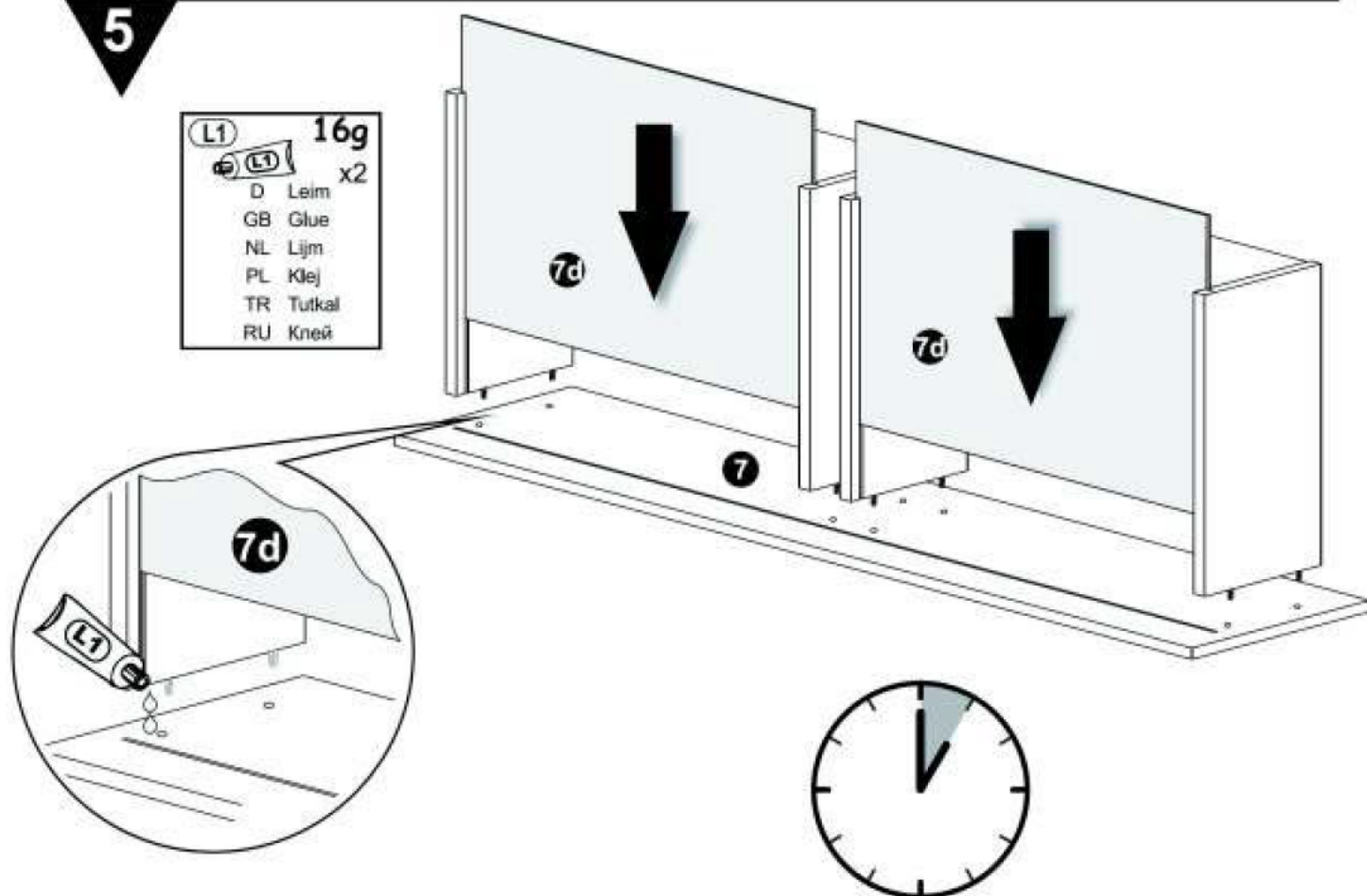

6

<b>R23</b>	<b>L=400</b>
x2	

<b>S3</b>	
	3,5x13 x12

<b>S5</b>	
	US03x16 x10

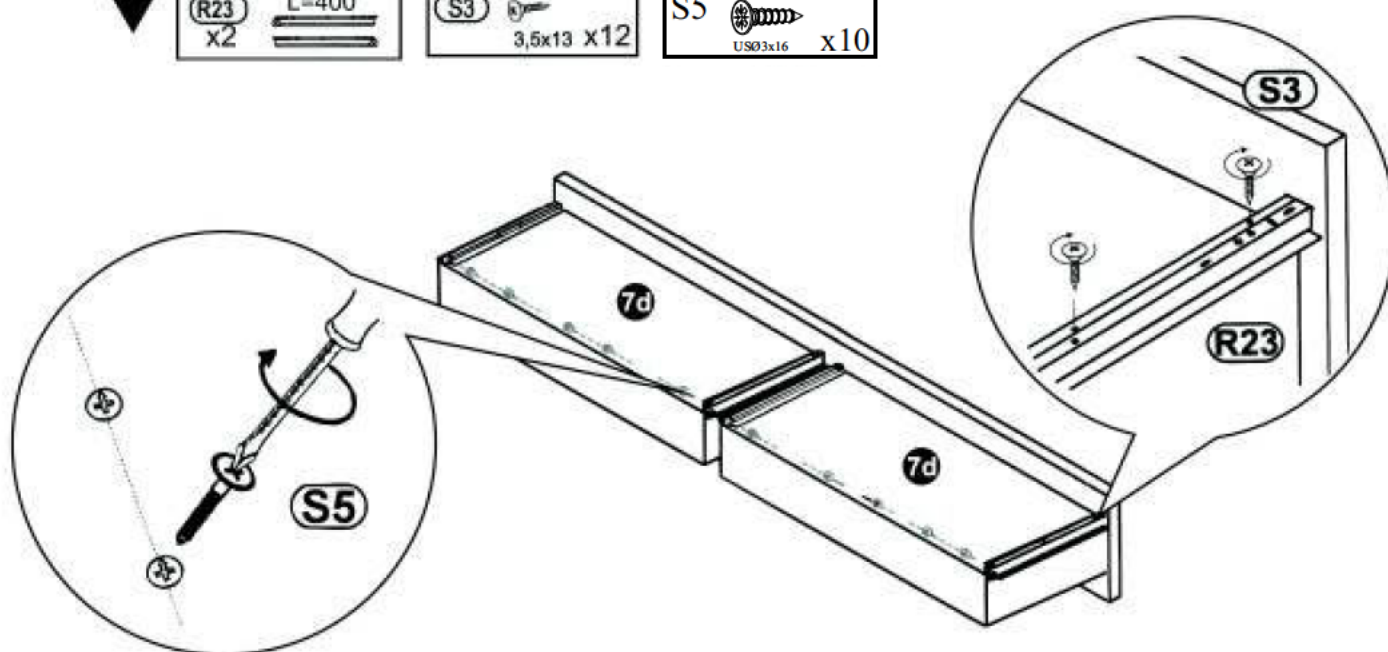

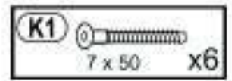
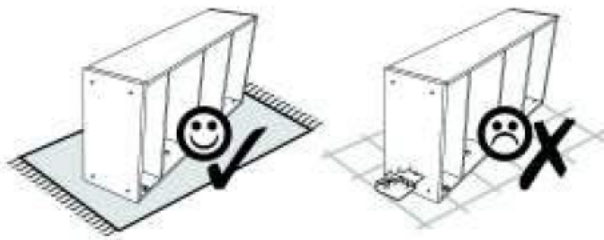

**7**

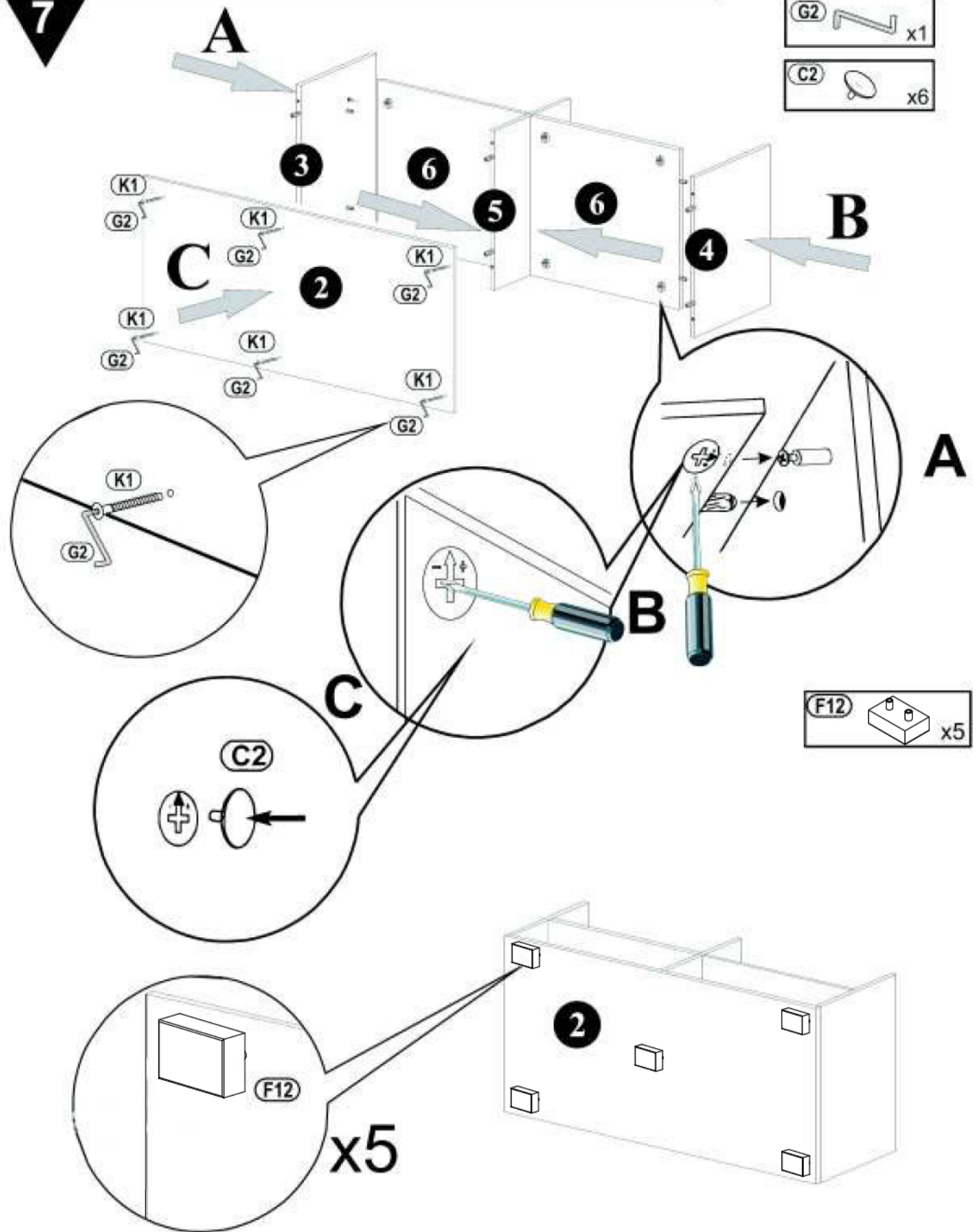

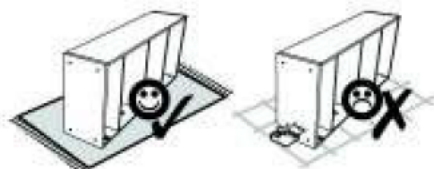



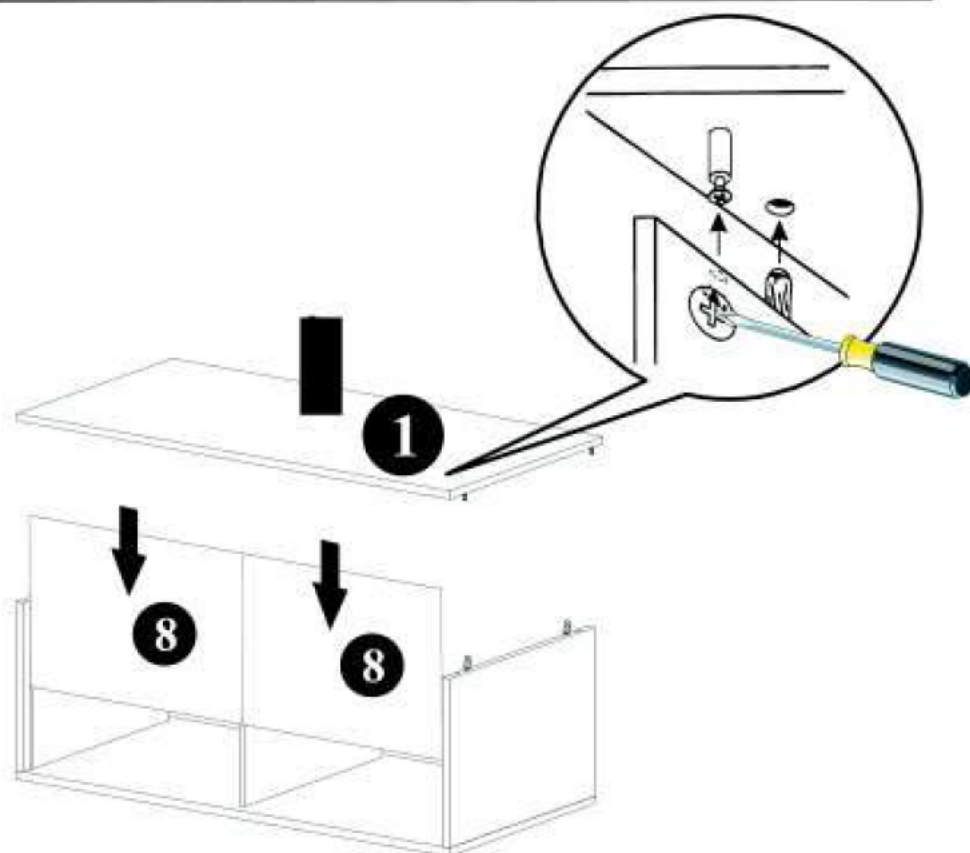
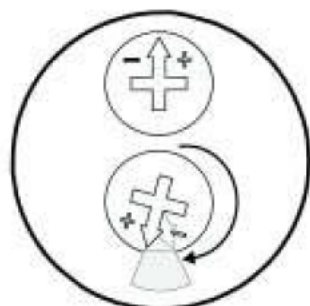

8



9

- (F1)  x3
- (S5)  3x20 x3
- (C4)  ø 40 x2
- (B3)  ø1.4x25 x10

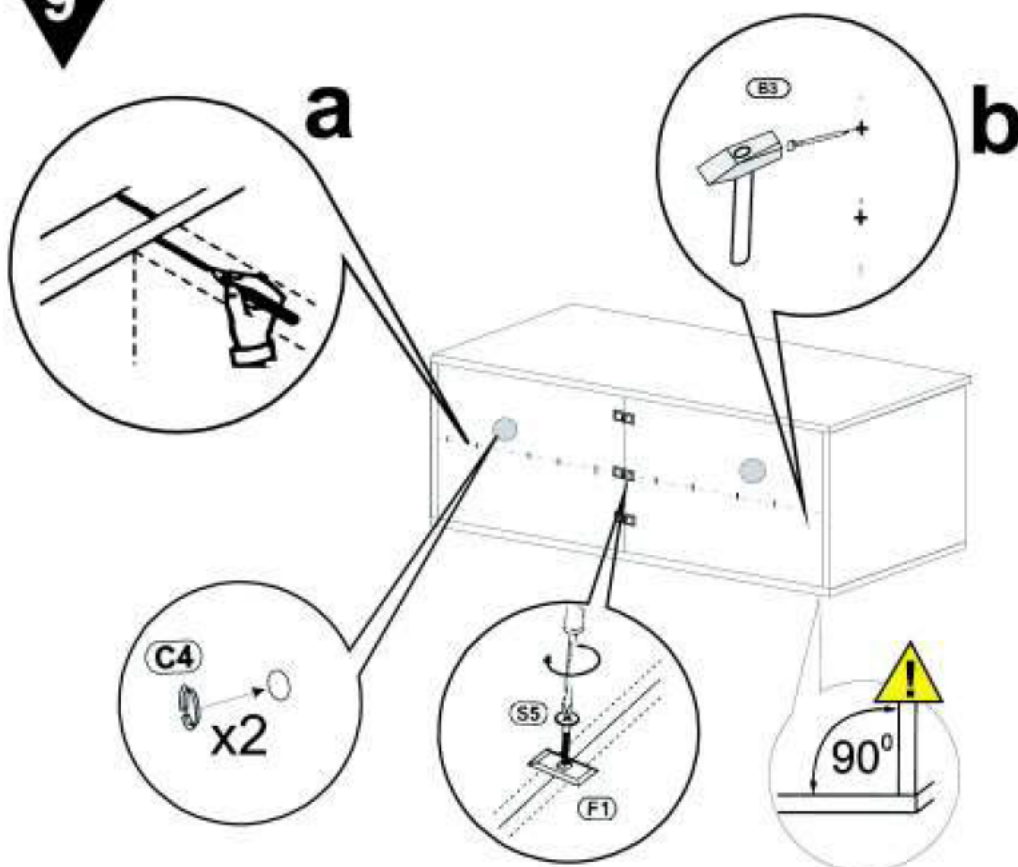

10

wypoziomować  
waagerech  
ausrichten

**U34** L=148/R=128  
L=148 x2

**P7** 4x30 x4

