

CANOFIX® Installation Guide

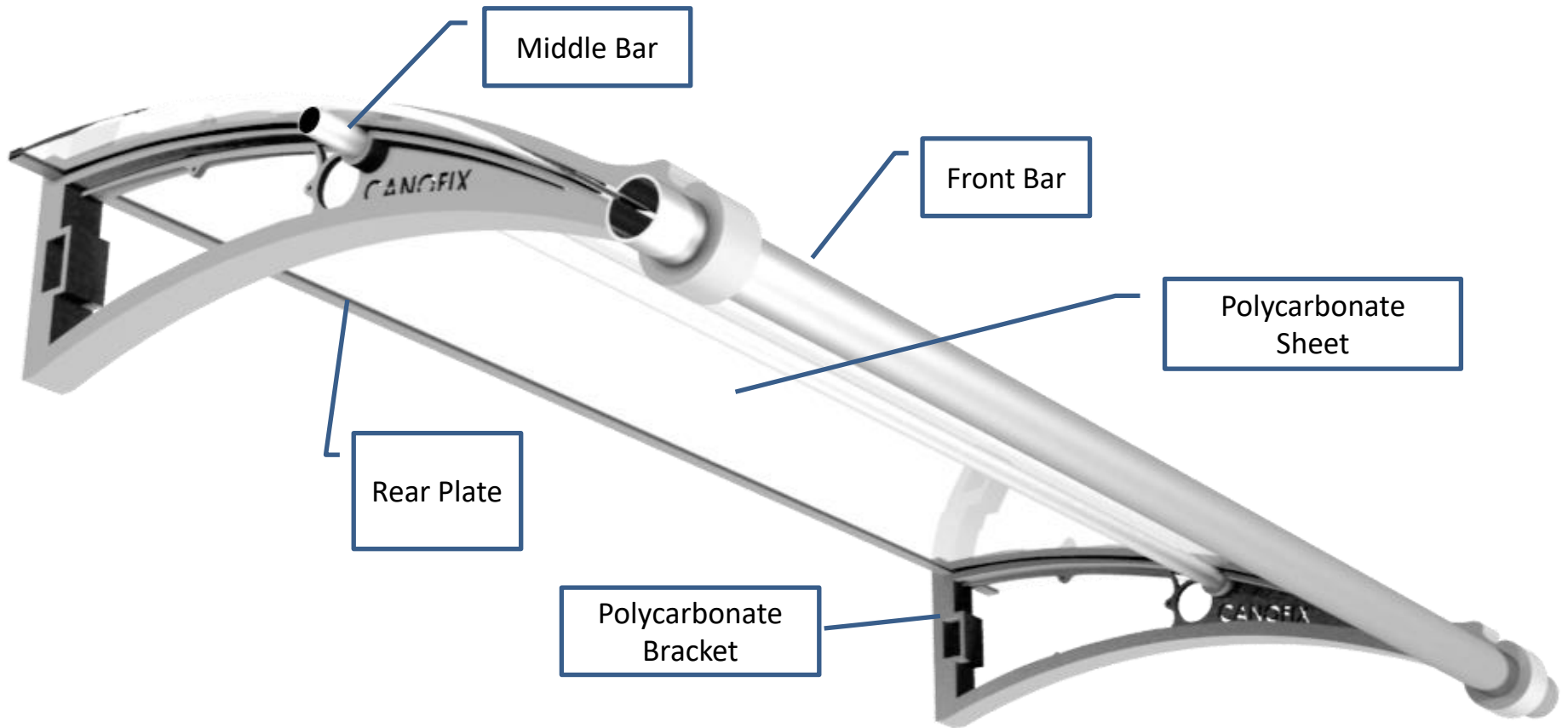

CANOFIX BRACKET TYPE & SIZE (Depth x Width unit: mm)

PC650

180x630 (DepthxWidth unit: mm)



PC1270

260x1225 (DepthxWidth unit: mm)



PC1000

260x965 (DepthxWidth unit: mm)



PC1500

280x1500 (DepthxWidth unit: mm)



CANOFIX®

Components



Fixing Materials



Brackets (Black or Grey)



Aluminum Bars (Front & Middle), Rear Bars, Edge Strips)



Solid Polycarbonate Sheets in Rolls (Clear or Light Bronze)

CANOFIX®

1. Locating the Brackets on the Wall

1. You will need: Drill (ideally cordless) with 14mm Drill bits (and smaller ones for initial drilling), Ratchets, Ring Spanners, Screwdrivers, Set Square or Ruler, Pencil, Utility Knife, Ladder, Gloves, Rubber Hammer and/or Spirit Level.

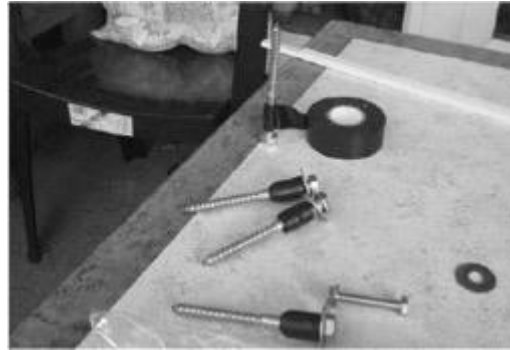

2. We provide robust 14mm anchors (rawl bolts, 2 anchors a bracket). Depending on the wall type, some customers use 90mm M8 stainless steel coach bolts with M8 penny washers in order to brush out the space (above middle pic). We recommend you use tape on the part of the drill to measure the depth of the anchor bolts. Drill into the wall precisely 47mm deep as the foot of the bracket is thick.



3. Set the drilling locations by placing the “notched” rear plate onto the wall. With a pencil, mark the wall where the “notches” are, as this is where you should fix your brackets. Use a plate(or a ruler) to draw and create two bracket holes for the bracket to be placed into.

2. Fitting and Assembling the Whole Unit

CANOFIX®



4. Fix the brackets to the wall by drilling the marked holes with a 14mm drill bit only by 47 or 48mm deep into the wall and then using a spanner to tightly fix the bracket onto the wall.
5. Position the “notched” rear plate sliding back into the now-fixed bracket opening the bracket top, and insert the middle support bar(s) and front bar through each bracket (it helps to use a rubber hammer).
6. Slide the solid polycarbonate sheet into the brackets from the front, making sure it is inserted into the end of the rear plate. Carefully insert the sheet into the front bar and securely clamp the bracket using the nuts and bolts supplied.
7. To finish off, use the supplied self-tapping screws to tighten the top of the bracket, the sheet and the middle bar together just to make sure the whole structure does not rattle. Place the edge strips on the brim of the polycarbonate sheet and the black caps on either end of the tubes.

FAQs

- It is possible to apply waterproof adhesives or flash band on any potential gaps (i.e. between the wall and the brackets). Normally no gaps in between.
- The carvings of the front bar can easily be cut-off using pliers (like a tin-cutting), so the front bar can function as a gutter.
- Installing larger sheets (5m+ long) may require 2-3 people to lift, as they come in one single long sheet as a roll. Installation may take 4-5 hours in total depending on the size.
- Connectors and caps are always pre-fitted to the bars.
- Do not forget to place the two edge strips on the edges of the sheet and always tighten the whole structure using the self-tapping screws in order to complete installation.
- Please find our web info (www.canofix.co.uk/installation2) and Youtube (Search “Canofix”) for further installation guidance.

CANOFIX®

1.5x 7.5m; Single Sheet Canofix
for Large Garden Doors



Front Bar Easily
Convertible into Gutters



Extra Support
Side Bars



Canofix 1x2m for Front Doors

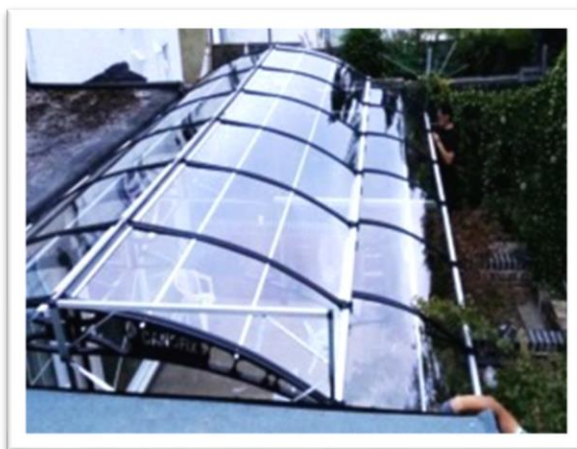

Canofix 4x6m stand-alone garden
shelter with 4 pillars and 2 bridges



For Long Sideways/ Walkways

Canofix® Canopies are Suitable for: Front Doors, Balcony Windows, Entire House Walls, External Staircases, Garden Doors, Shelters, Storage Sheds, Car Ports, Kiosks, Greenhouses, Conservatories, Walkways, Sideways and Much More!

