

Recommended Maximum Weight

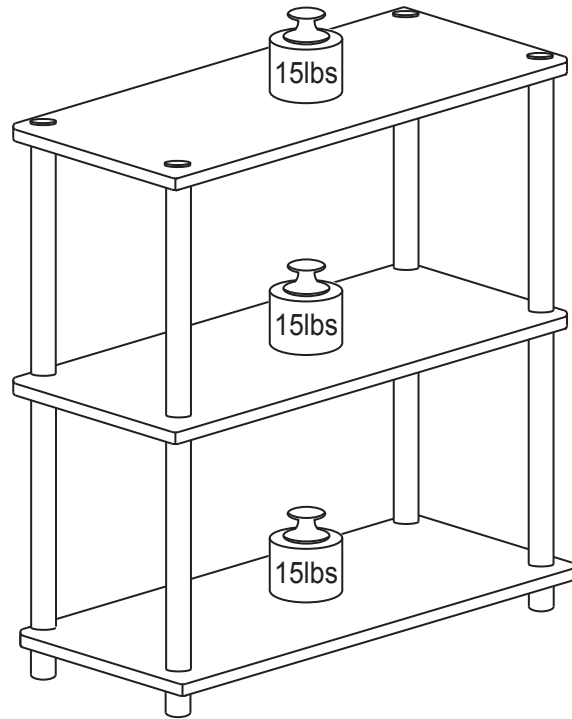

WARNING:

>This unit has been designed to support the maximum loads shown. Exceeding these load limits could cause sagging, instability, product collapse, and/or serious injury.



>DO NOT allow children to climb on unit.

>Put heavier items on lower shelves.

Assembly Instruction

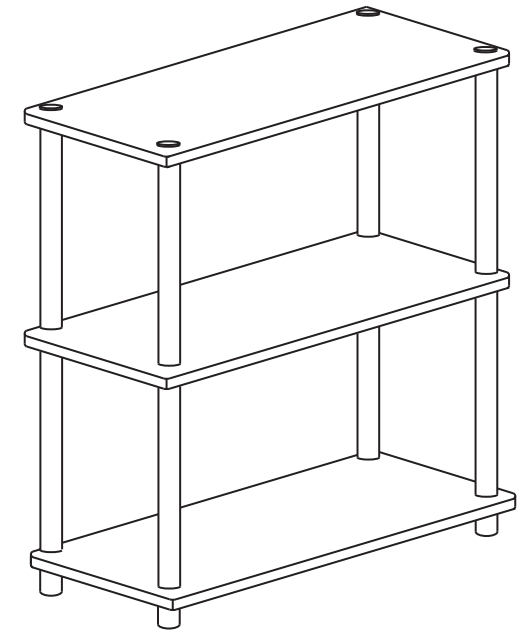
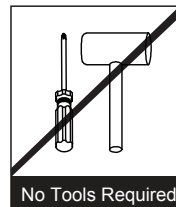
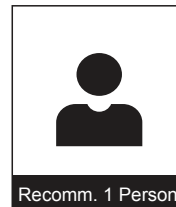
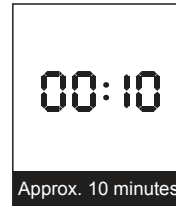
3-Tier Compact Multipurpose Tube Shelf Display Rack



No	Hardware List	Qty
1	Pole 	8pcs
2	Cap 	4pcs
3	Leg 	4pcs

No	Parts List	Qty
A	Shelf 	3pcs

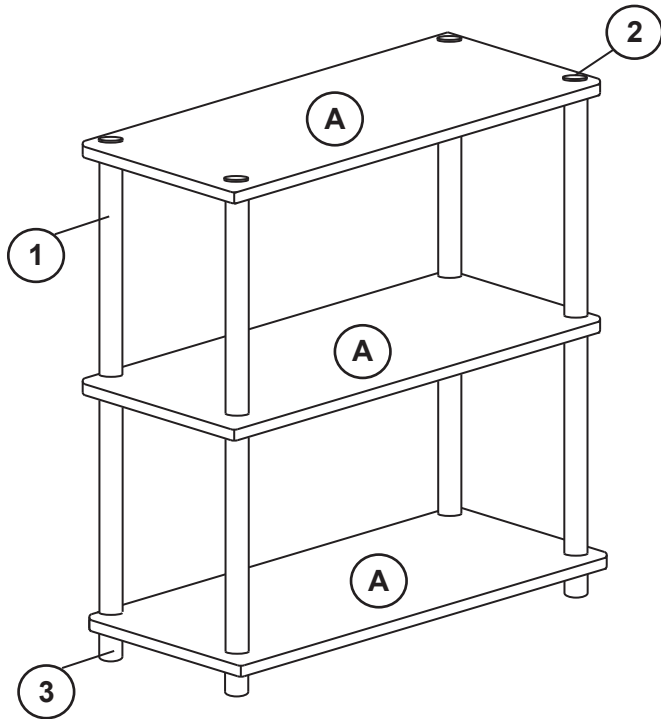

USEFUL HINTS BEFORE YOU START:

1. Read each step carefully before starting.
2. It is important that each step is performed in correct order to avoid difficulties.
3. Identify, sort and count the parts before assembly.
4. Assemble your furniture on packaging cardboard to prevent scratch or damage.
5. Clean the product with mild cleanser using soft damped cloth. Do not use harsh or abrasive cleanser.
6. Using incompatible hardware might cause damage to product.

STEP 1

- 1.1 Attach Leg (3) to the bottom of Shelf (A) and tighten with Pole (1), as shown.
- 1.2 Attach center Shelf (A) and tighten with Pole (1).
- 1.3 Attach top Shelf (A) to the top of assembled unit.

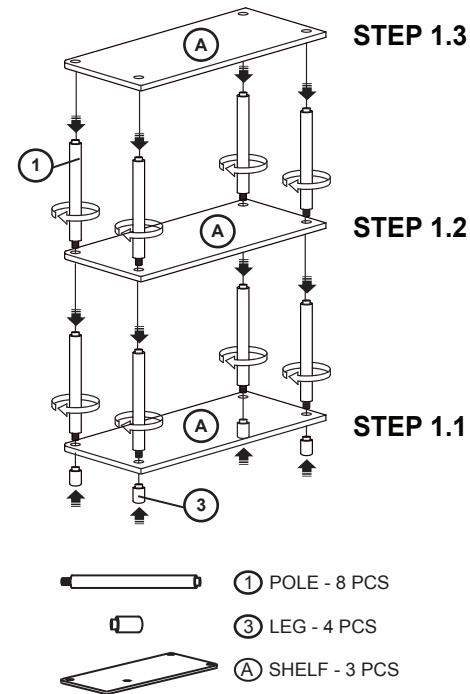

STEP 2

- Tighten Cap (2) on the top Shelf (A), as shown.

