

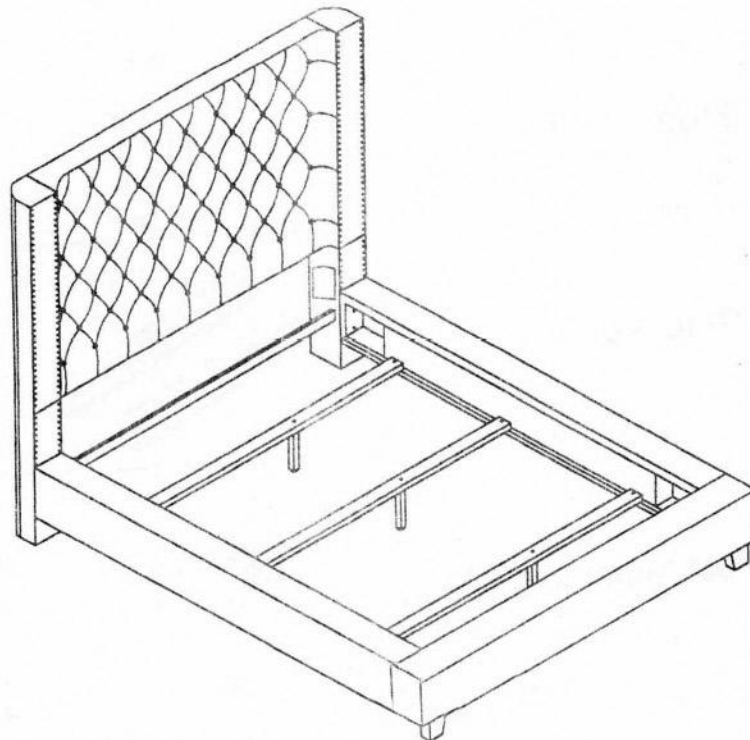

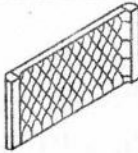









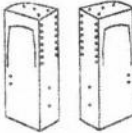
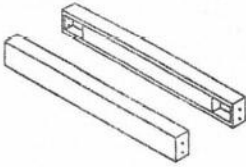





Assembly Instruction

IMPORTANT: PLACE ALL PARTS ON A CLEAN AND SMOOTH SURFACE SUCH AS A RUG OR CARPET
AVOID THE PARTS FROM BEING SCRATCHED
KINDLY FOLLOW THE ASSEMBLY INSTRUCTIONS STEP
DO NOT TIGHTEN ALL SCREWS UNTIL THE BED IS FULLY SET-UP

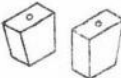

Carton	Disignation	Part	Hardware
	Headboard		
	Footboard		
	Slat (3pcs)		
	HB Support Rail		
	Head board leg (2pcs)		
	Side Rail (2pcs)		 #A x 14pcs  #B x 2pcs  #C x 6pcs  #D x 22pcs  #E x 8pcs  #F x 14pcs  #G x 1pc  #H x 14pcs  #I x 6pcs  #J x 1pc  #K x 2pcs
	Foot board Leg (2pcs)		
	Support leg (3pcs)		

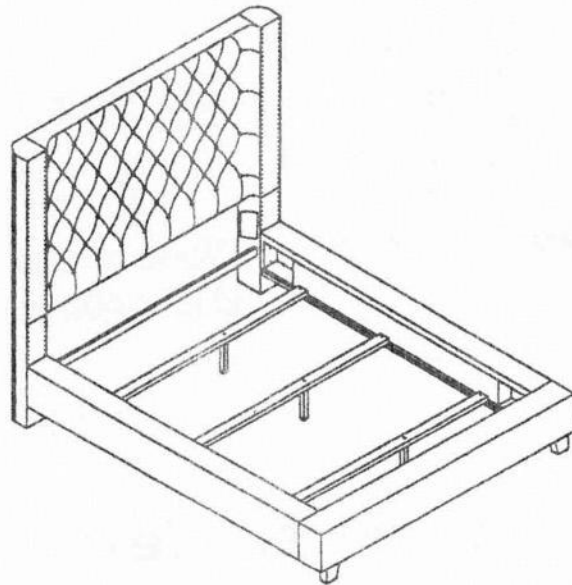

PARTS

#1 1pc

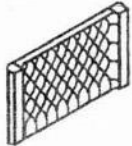

Headboard

#2 2pcs

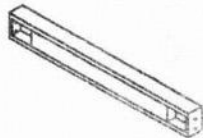

Side Rail

#3 1pc

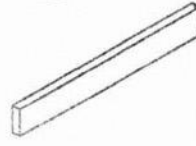

Footboard

#4 2pcs



FB Leg

#5 3pcs



Support leg
170x30x30mm

#6 3pcs



Slat

#7 1pc



HB Support Rail

#8 2pcs

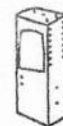

HB Leg (L/R)

HARDWARE

#A 14pcs



Threaded Stud
Ø5/16" x 3-1/4"

#B 2pcs



Bolt
Ø5/16" x 2-1/2"

#C 6pcs



Bolt
Ø5/16" x 3/4"

#D 22pcs



Lock Washer
Ø5/16"

#E 8 pcs



Flat Washer
Ø5/16" x 19mm

#F 14pcs



Flat Washer
Ø5/16" x 22mm

#G 1pc



Allen Wrench 5mm

#H 14pcs



Hex Nut Ø5/16"

#I 6pcs



Screw
Ø5/16" x 38mm

#J 1pc



Wrench 12mm

#K 2pcs



Wood tenon
Ø10 x 40mm

#L 2pcs



Connecting iron

Exploded View

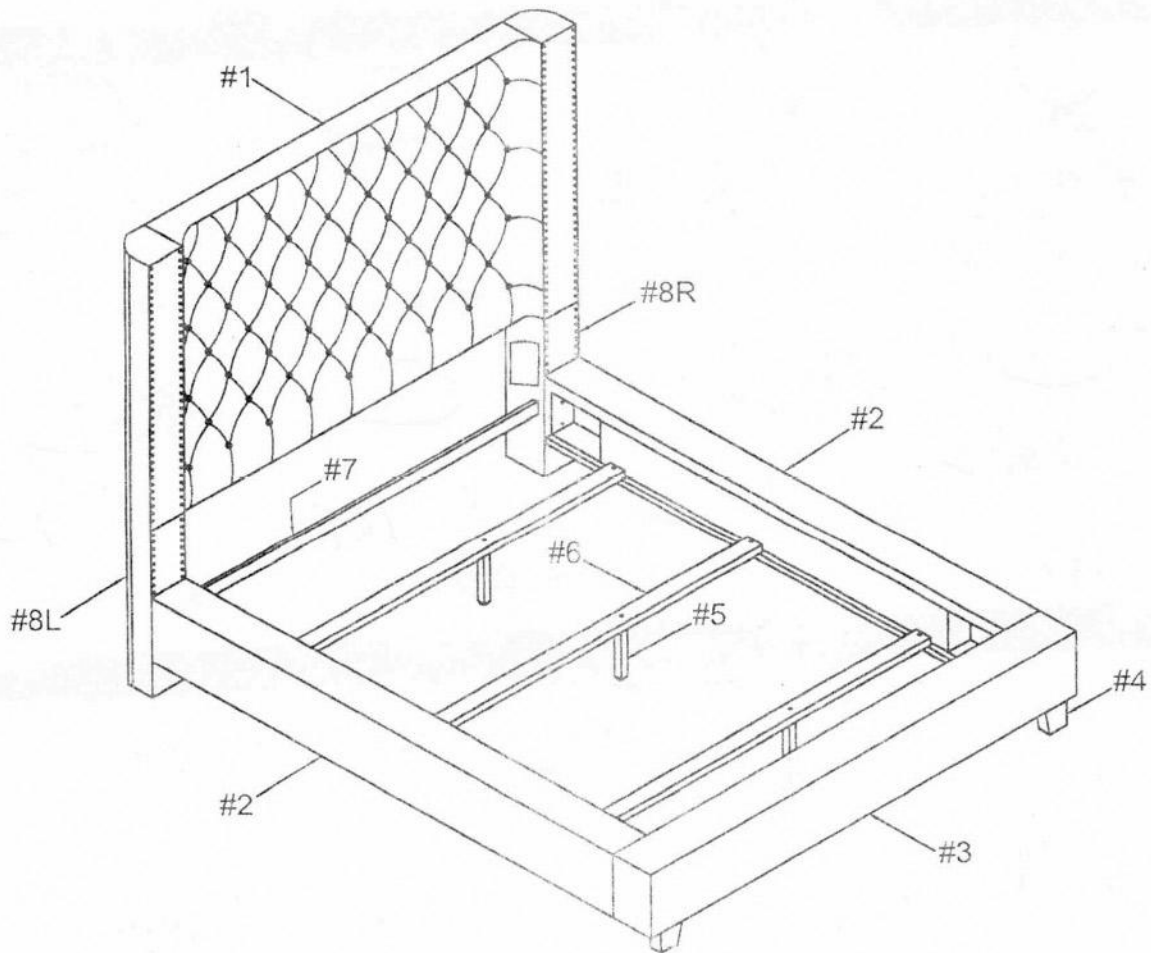

ASSEMBLY INSTRUCTIONS

1

- Part #3 x1pc
- Part #4 x2pcs
- Hardware #B x2pcs
- Hardware #D x2pcs
- Hardware #E x2pcs
- Hardware #G x1pc

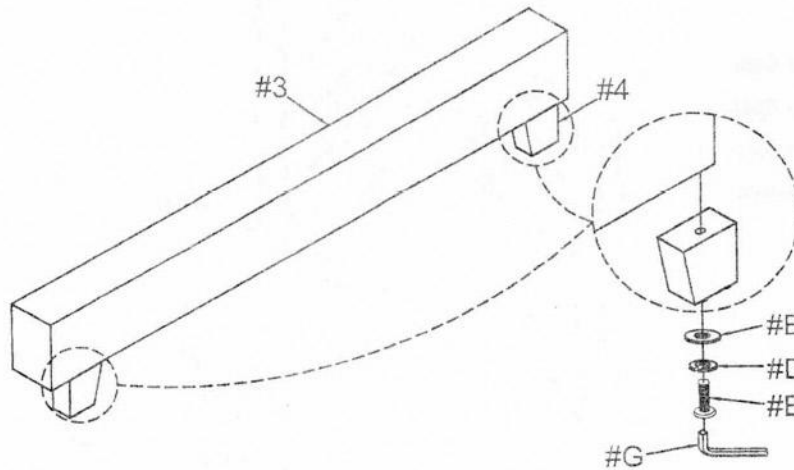

2

- Part #1 x1pc
- Part #8 x2pcs
- Hardware #A x6pcs
- Hardware #D x6pcs
- Hardware #F x6pcs
- Hardware #H x6pcs
- Hardware #K x2pcs

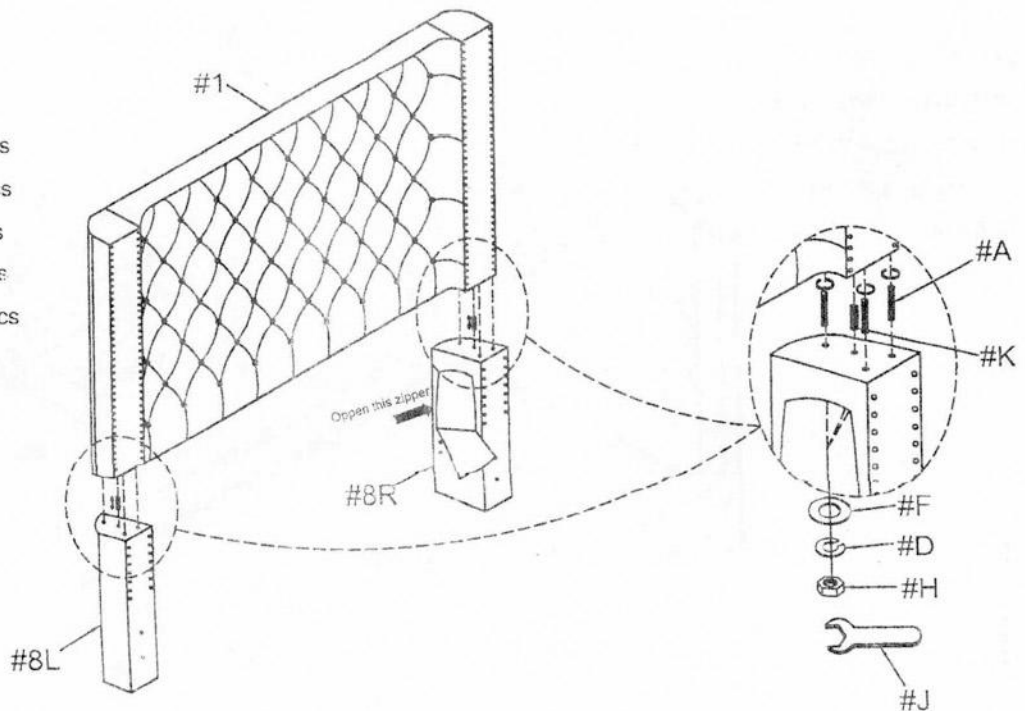

ASSEMBLY INSTRUCTIONS

3

- Part #7 x1pc
- Hardware #C x 6pcs
- Hardware #D x 6pcs
- Hardware #E x 6pcs
- Hardware #L x2pcs

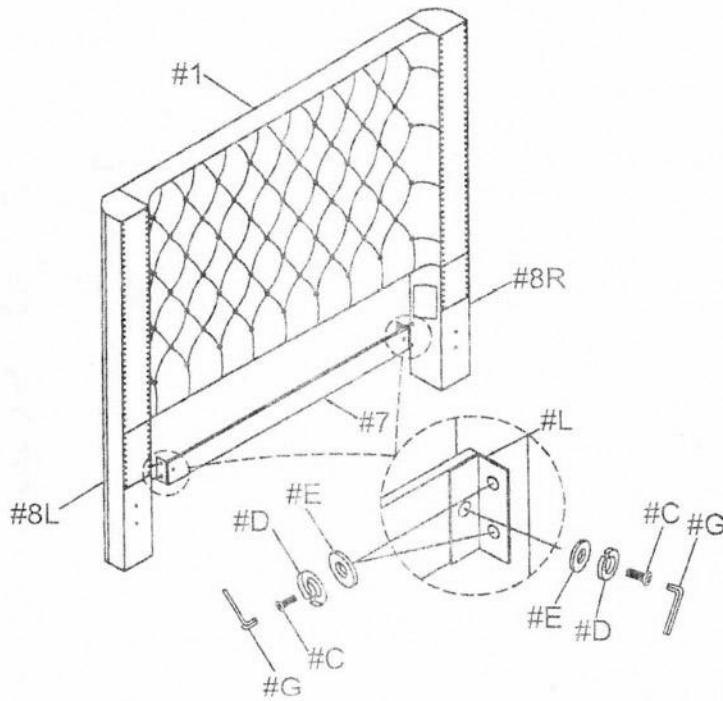

4

- Part #2 x2pcs
- Hardware #A x8pcs
- Hardware #D x8pcs
- Hardware #F x8pcs
- Hardware #H x8pcs

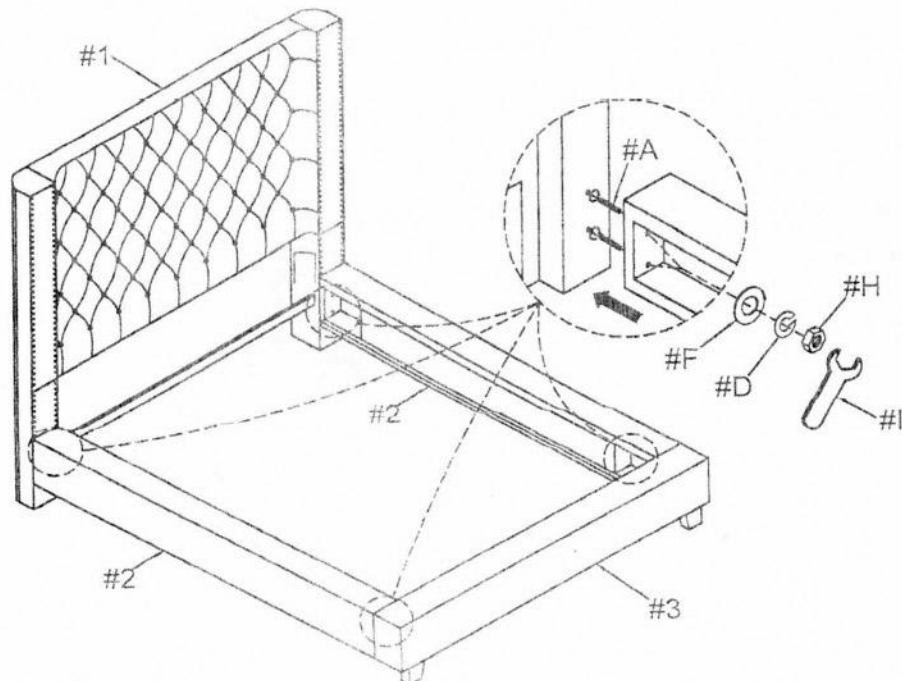

ASSEMBLY INSTRUCTIONS

5

Part #5 x1pc
Part #6 x1pc

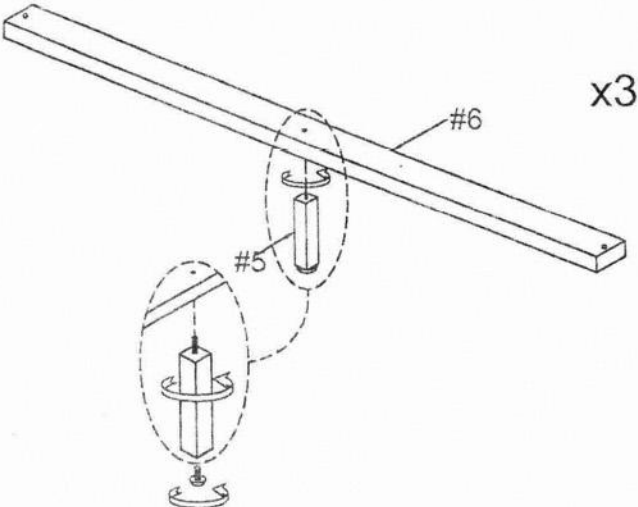

6

Hardware #1 x6pcs

