

ASSEMBLY INSTRUCTION

ITEM NO.:D88033.D88034.D88035.D88036.D88037-L/R

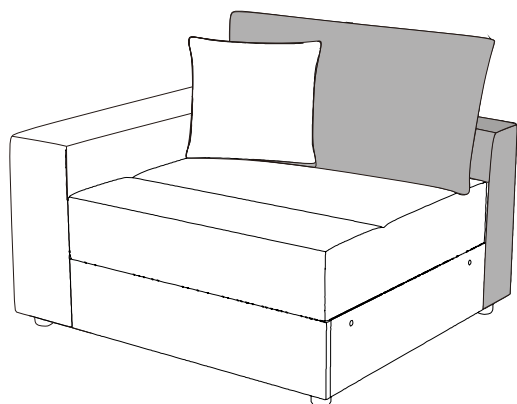

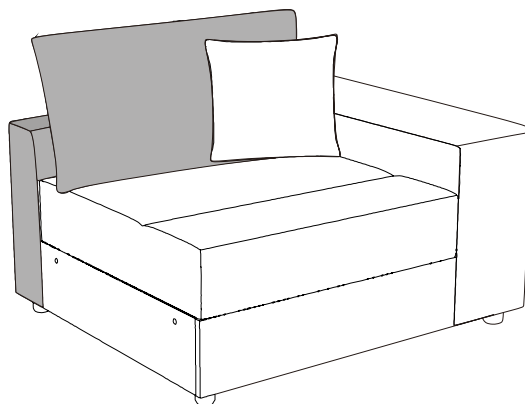

L





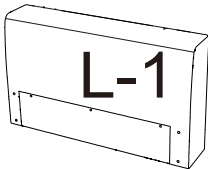
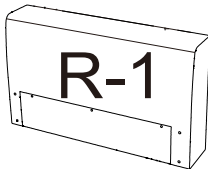
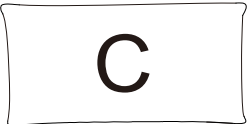

R

PARTS LIST

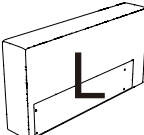
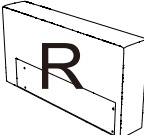
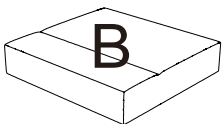

BOX:L/R

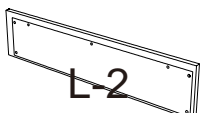
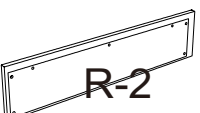
 <p>L-1 Backrest x1</p>	 <p>R-1 Backrest x1</p>	 <p>C Back cushion x2</p>	 <p>H Support Bar x4</p>
--	--	---	--

BOX-ARM

 <p>L Left Arm x1</p>	 <p>R Right Arm x1</p>	 <p>B Seat cushion x2</p>	 <p>D Throw pillow x2</p>
 <p>L-2 Base Frame Front Panel x1</p>	 <p>R-2 Base Frame Front Panel x1</p>	 <p>G Base Frame Side Panel x2</p>	 <p>M Slats x2</p>

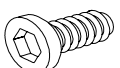
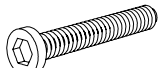
HARDWARE LIST INSIDE L/R Armrest

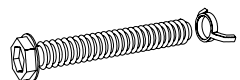
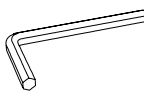
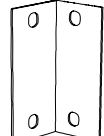
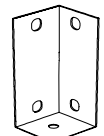
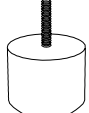
 <p>1 1/4*20mm x32</p>	 <p>2 1/4*50mm x8</p>	 <p>3 19mm x20</p>	 <p>4 5/16*75mm x6</p>
 <p>5 30mm*100mm x1</p>	 <p>6 x6</p>	 <p>7 x2</p>	 <p>8 x8</p>

BEFORE ASSEMBLY

Open up Velcro of Non-Woven Fabric cover on the bottom to remove hardware, legs and parts.

1. Please open the black woven fabric with Velcro closure on the bottom of the frame then cut off the black straps before removing the parts for assembly.

2. After removing the cushion from the compress bag, please allow air to flow through the cushion for few days. You can try to fluff cushion by push in and push out on all four sides of the cushion. Hitting the top/front of the cushion with your hand to fluff them after installation.

3. Please allow at least 24 hours for the cushions to recover to its natural state after removing from the package.

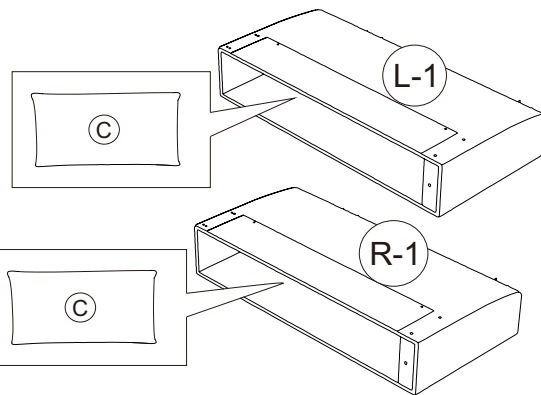
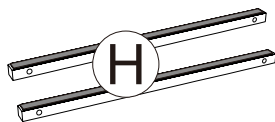

Take the parts from the A/R Arm Box

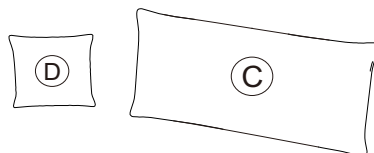

L.

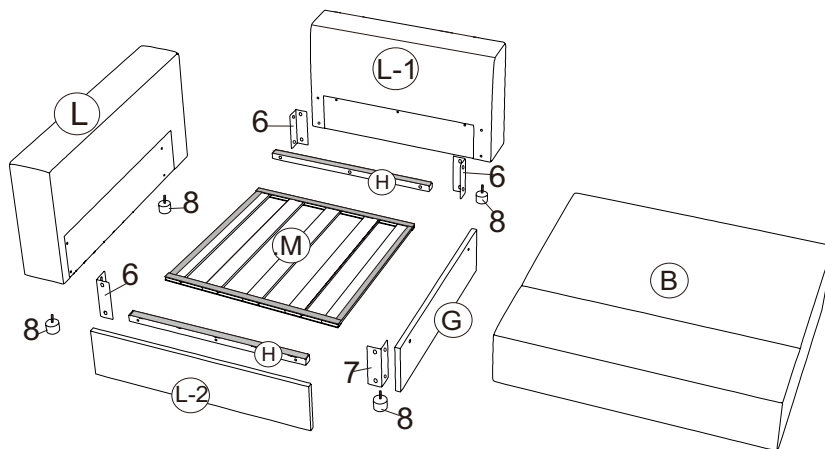

Take the parts from the A/R Arm Box

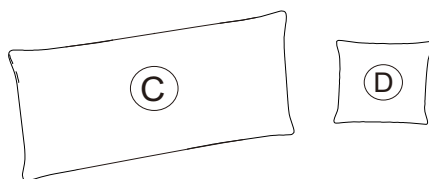

R.

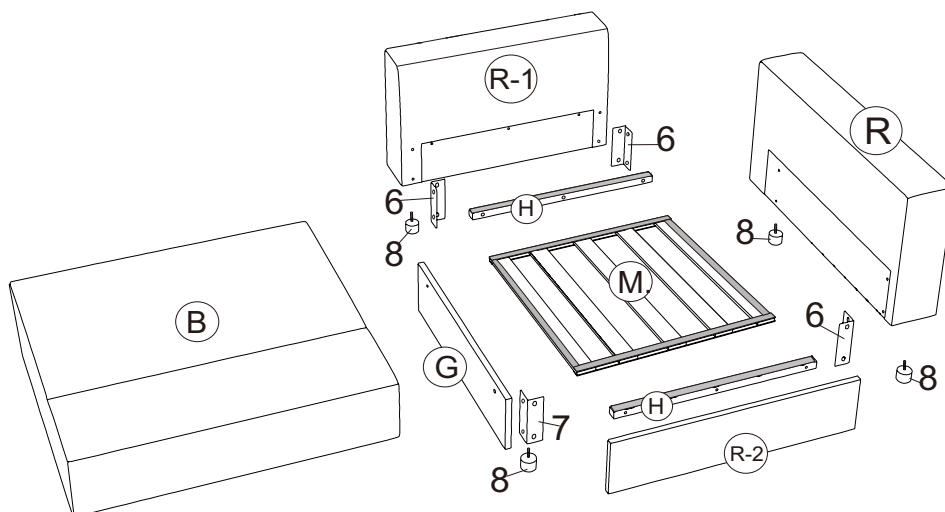

Step1

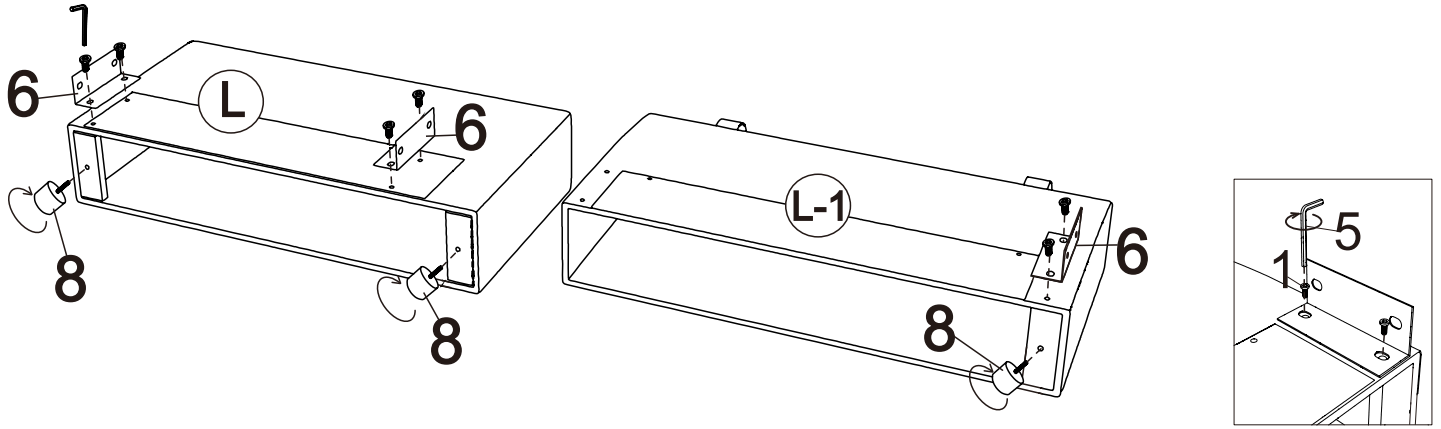

Step2

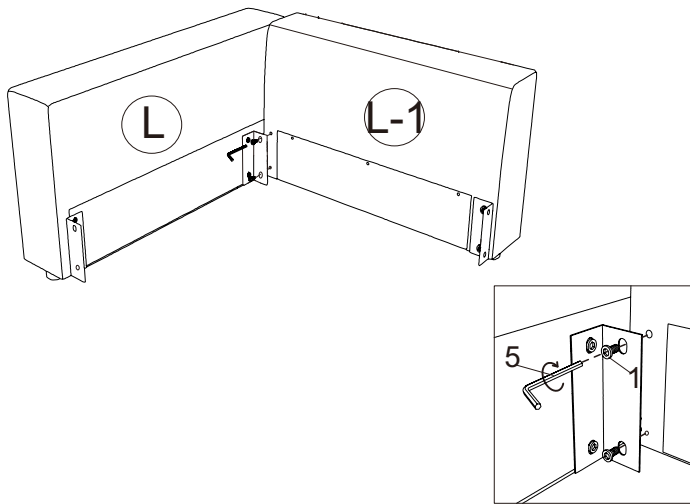

Step3

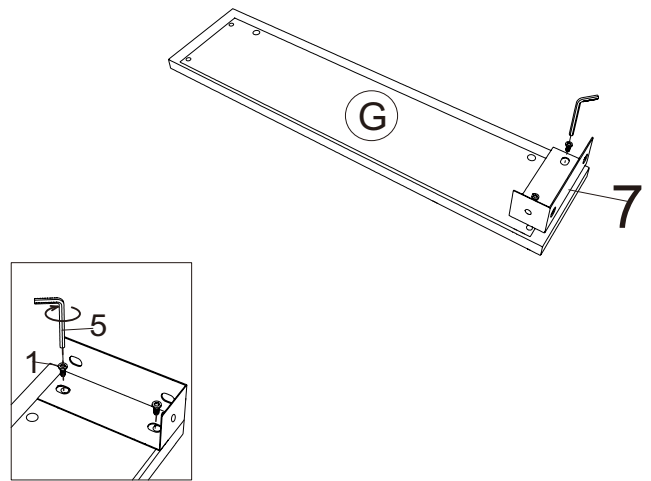

Step4

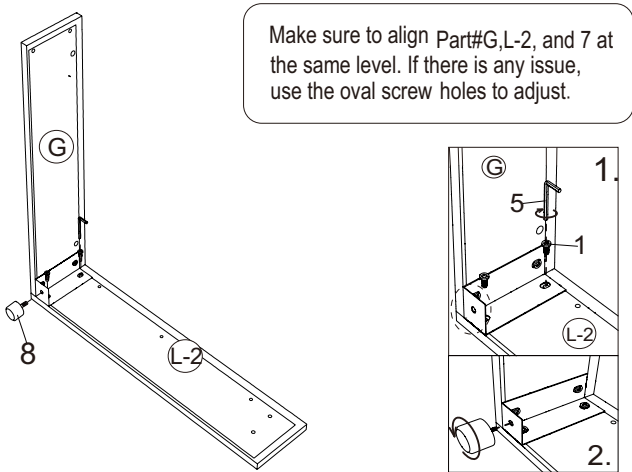

Step5

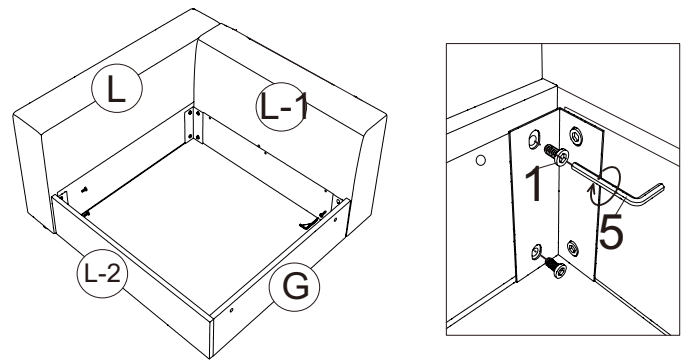

Step6

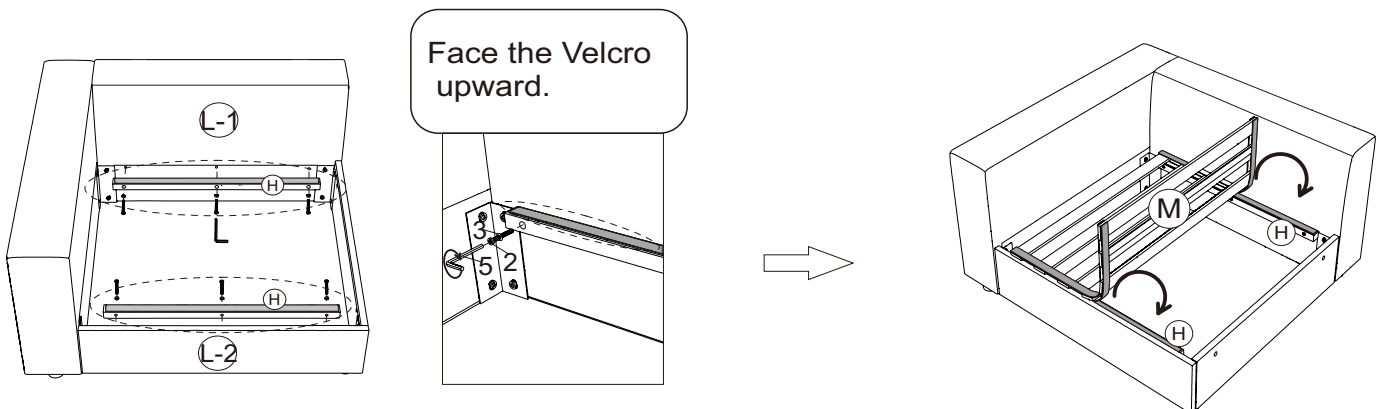

Step7

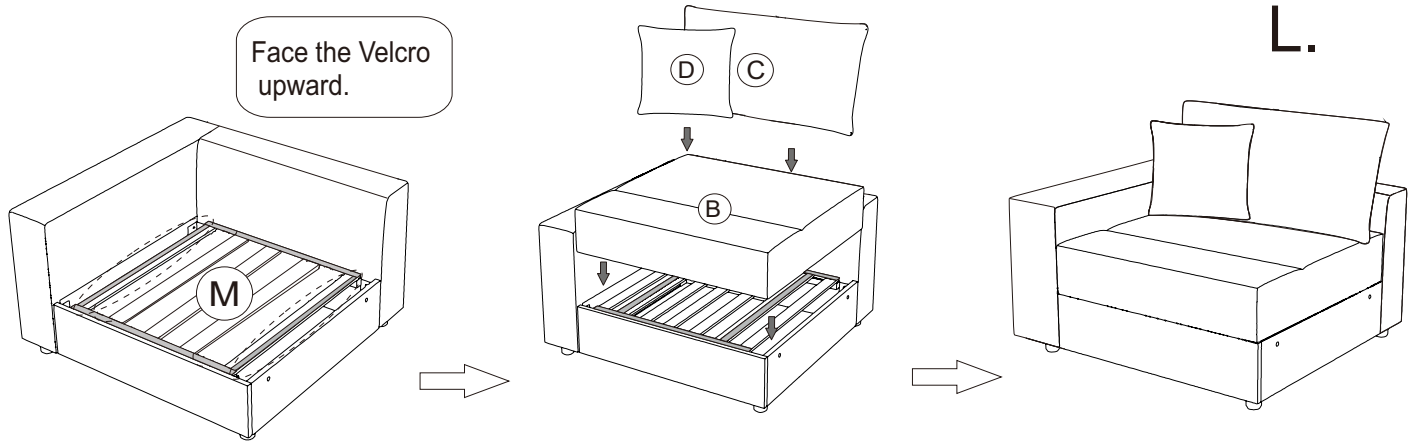

Step1

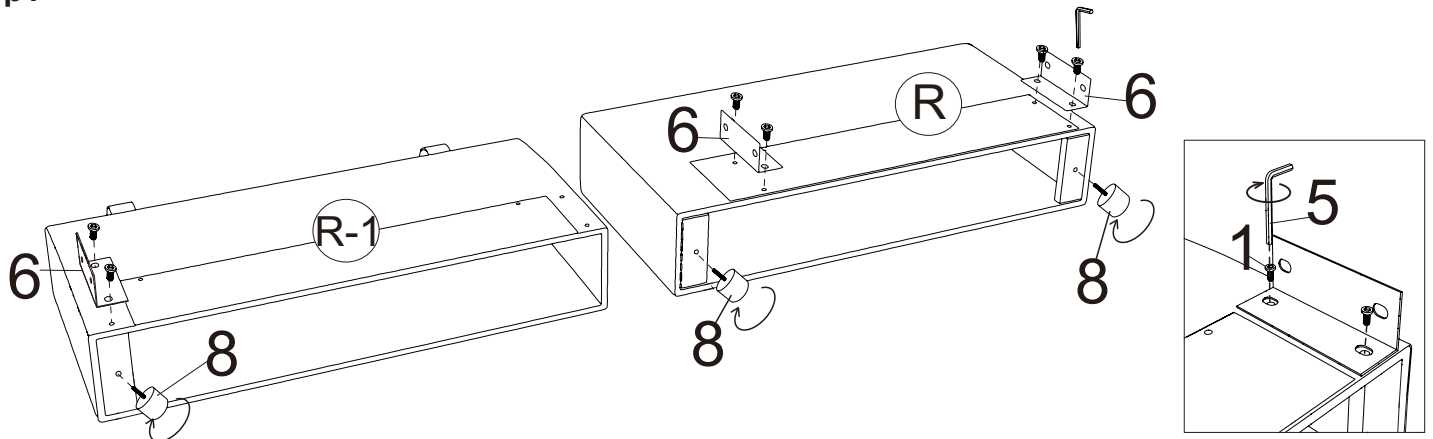

Step2

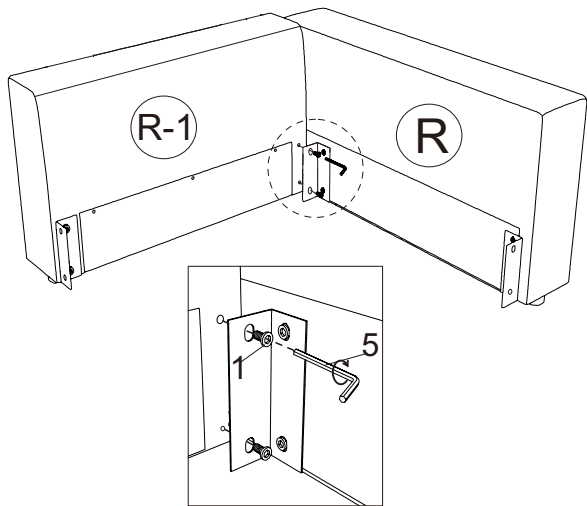

Step3

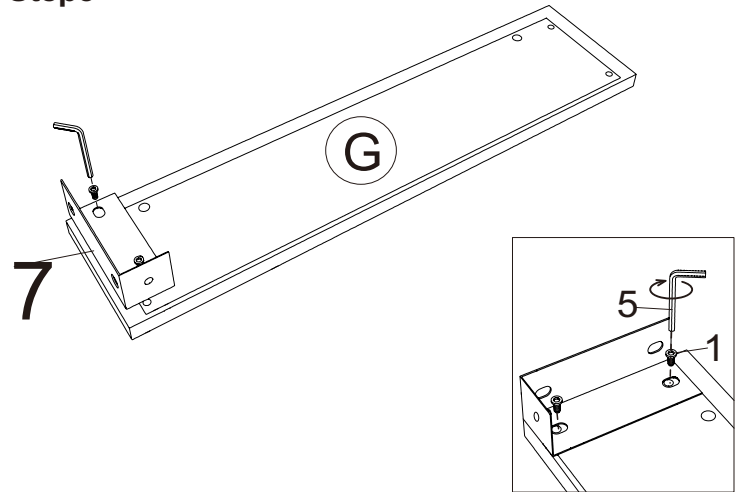

Step4

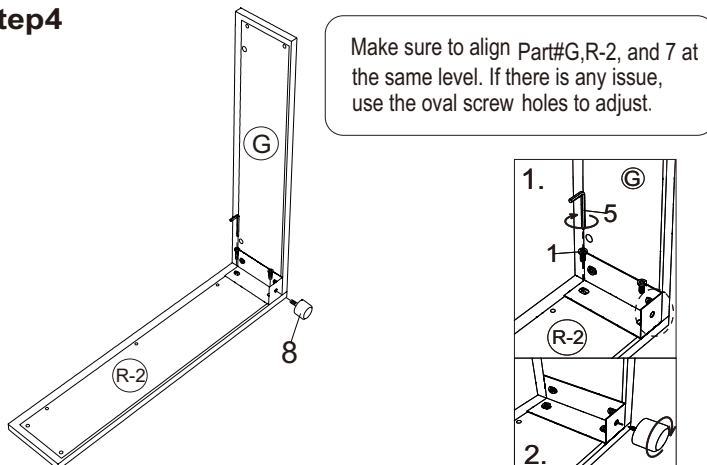

Step5

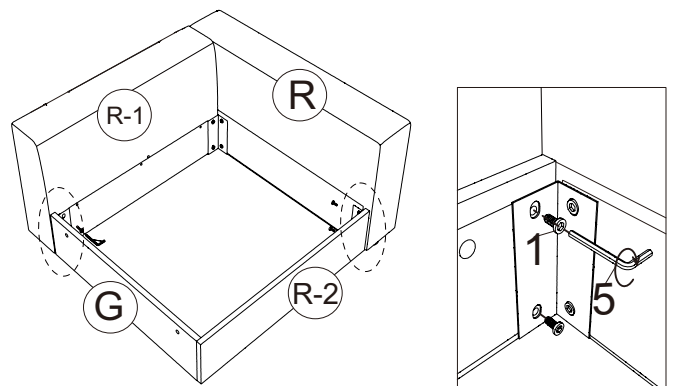

Step6

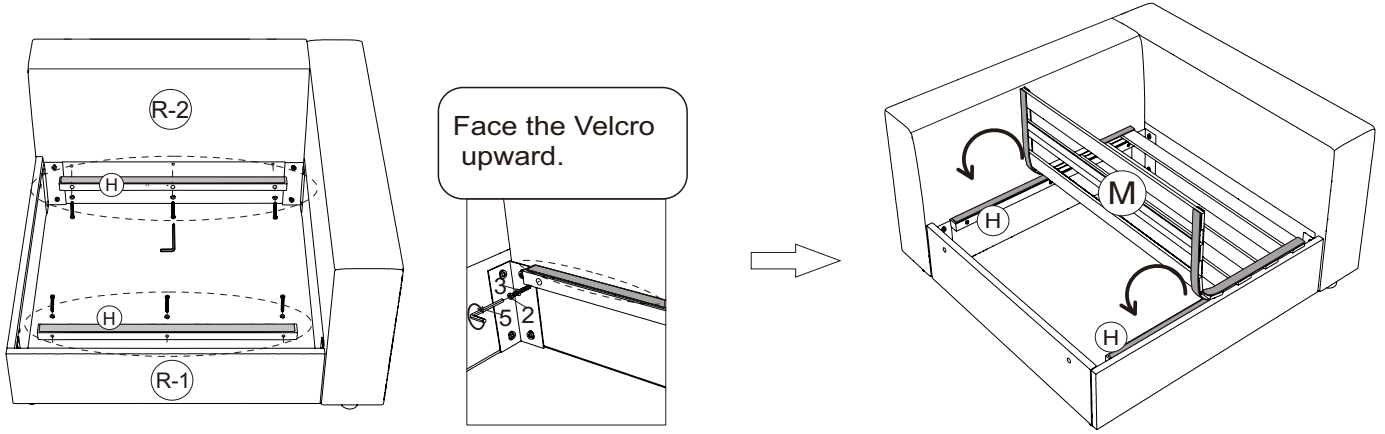

Face the Velcro upward.

