

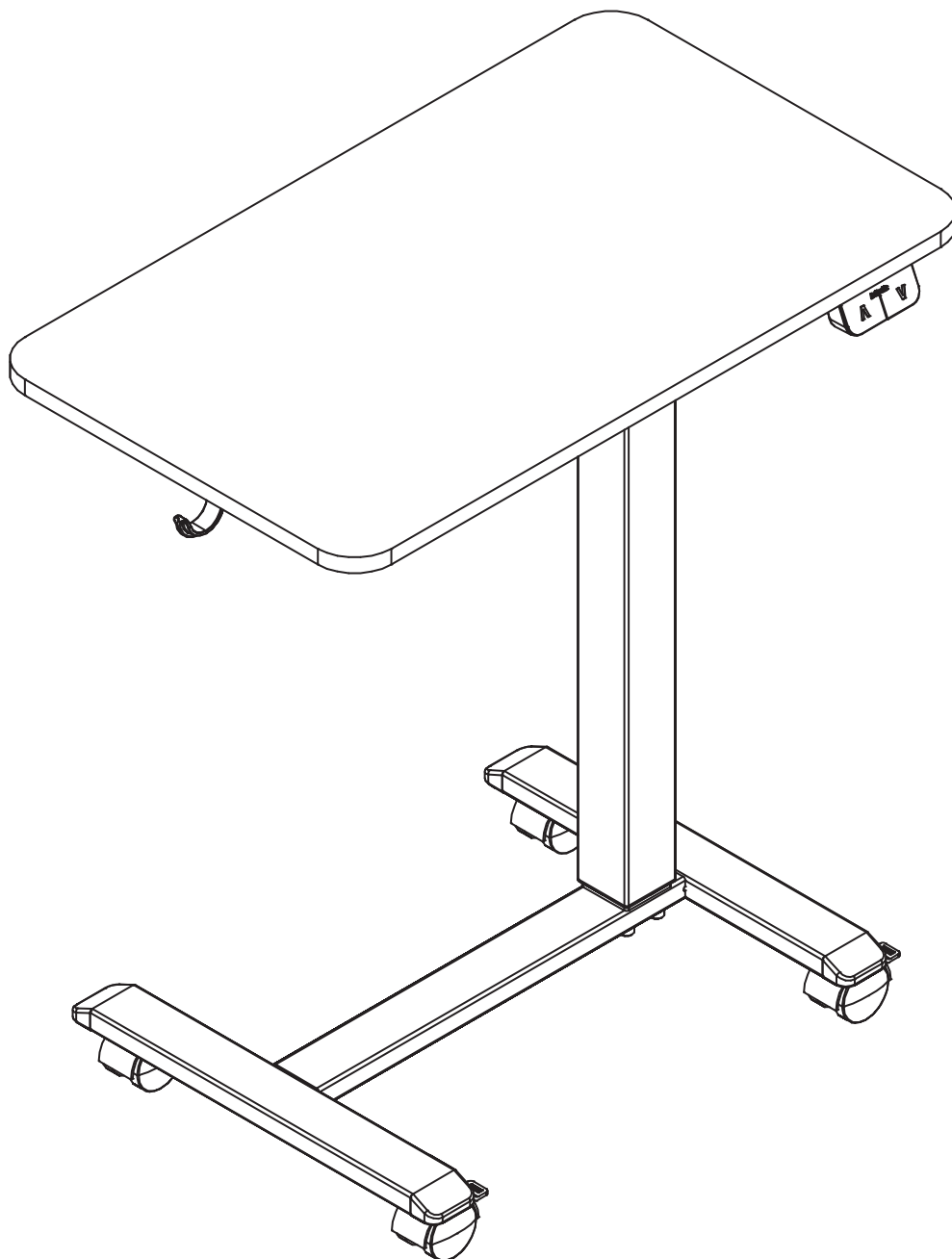

STANDING DESK

ES-MB1 26.77"



German(DE)

Warnung:

- Halten Sie Kinder und Tiere während des
- Gebrauchs vom Schreibtisch fern und stellen Sie sicher, dass der Schreibtisch keine Wände berührt. Bitte entfernen Sie Hindernisse 20 cm über dem Schreibtisch und 51 cm unter dem Schreibtisch während des Betriebs.
- Betreiben Sie diesen höhenverstellbaren
- Schreibtisch nur in einer Umgebungstemperatur von 0°C bis 40°C.
- r sicheren Position. Bitte lesen Sie diese Anweisungen sorgfältig durch, bevor Sie einen höhenverstellbaren Schreibtisch verwenden.
- Die Firma lehnt jegliche Garantie oder Haftung für Schäden oder persönliche Verletzungen ab, die durch abnormales oder außerhalb der Gerätebetriebsvorschriften entstehen.
- Personen ist es untersagt, sich auf den Tisch zu lehnen, um das Risiko des Umkippens zu vermeiden.
- Verwenden Sie keine scharfen Gegenstände, um die Tischplatte zu durchbohren oder zu zertrümmern.

French(FR)

Avertissement:

- Eloignez les enfants et les animaux du bureau pendant son utilisation et assurez-vous que le bureau ne touche aucun mur.
- Veuillez retirer les obstacles situés à 20 cm au-dessus du bureau et à 51 cm en dessous du bureau pendant le fonctionnement.
- Utilisez ce bureau réglable uniquement dans une température ambiante de 0°C à 40°C.
- Éloignez les produits des gaz corrosifs, des liquides et des objets poussiéreux.
- Gardez vos mains, vos pieds et autres parties du corps dans une position sûre pendant le fonctionnement.
- Veuillez lire attentivement ces instructions avant
- d'utiliser un bureau à hauteur réglable.
- La société décline toute garantie ou responsabilité pour tout dommage ou blessure personnelle résultant d'un fonctionnement anormal ou en dehors des réglementations d'utilisation de l'équipement.
- Il est interdit aux personnes de s'appuyer sur la table pour éviter les risques de basculement. N'utilisez pas d'objets tranchants pour percer ou
- briser les bureaux.

Spanish(ES)

Advertencia:

- Mantenga a los niños y a los animales alejados del escritorio durante su uso y asegúrese de que el escritorio no toque ninguna pared.
- Por favor, retire los obstáculos a 20 cm por encima del escritorio y a 51 cm por debajo del escritorio durante el funcionamiento.
- Utilice este escritorio ajustable solo en un entorno operativo con una temperatura de 0°C a 40°C. Mantenga los productos alejados de gases corrosivos, líquidos y objetos polvorientos. Mantenga las manos, los pies y otras partes del cuerpo en una posición segura durante el funcionamiento.
- Por favor, lea cuidadosamente estas instrucciones antes de utilizar un escritorio de altura ajustable. La empresa declina cualquier garantía o responsabilidad por cualquier dano o lesión
- personal resultante de un funcionamiento anormal o de regulaciones de funcionamiento fuera de equipo.
- Se prohíbe que las personas se apoyen en la mesa para evitar riesgos de vuelco. No utilice objetos afilados para perforar o romper
- los escritorios..

Italian(IT)

Avvertimento:

- Teneri bambini e gli animali lontani dalla
- scrivania durante l'uso e assicurarsi che la scrivania non tocchi nessun muro.
- Si prega di rimuovere gli ostacoli a 20 cm sopra la scrivania e a 51 cm sotto la scrivania durante il funzionamento.
- Utilizzare questa scrivania regolabile solo in un ambiente operativo con temperatura compresa tra 0°C e 40°C.
- Tenere i prodotti lontani da gas corrosivi, liquidi e oggetti polverosi. Tenere le mani, i piedi e altre parti del corpo in una posizione sicura durante il funzionamento.
- Si prega di leggere attentamente queste istruzioni prima di utilizzare una scrivania regolabile in altezza. La società declina qualsiasi garanzia o responsabilità per eventuali danni o lesioni
- personali derivanti da un funzionamento anormale o da regolamenti di utilizzo dell'attrezzatura al di fuori della norma.
- È vietato alle persone appoggiarsi sul tavolo per evitare rischi di ribaltamento.
- Non utilizzare oggetti appuntiti per forare o
- sfondare le scrivanie.

Alert:

- Keep children and animals away from the desktop during use and ensure that the desktop does not touch any walls.
- Please remove obstacles 20CM above the desktop and 51CM below the desktop during operation.
- Only operate this adjustable desk in the temperature of 32°F-104°F/0°C-40°C operating environment.
- Keep products away from corrosive gases,liquids,and dusty objects.
- Keep your hands,feet,and other body parts in a safe position while operating.
- Please read these instructions carefully before using an adjustable-height desk.
- The Company disclaims any warranty or liability for any damage or personal injury resulting from abnormal or outside-of-equipment operation regulations.
- People are prohibited from leaning on the table to avoid tipping risks.
- Do not use sharp objects to poke/smash desktops.

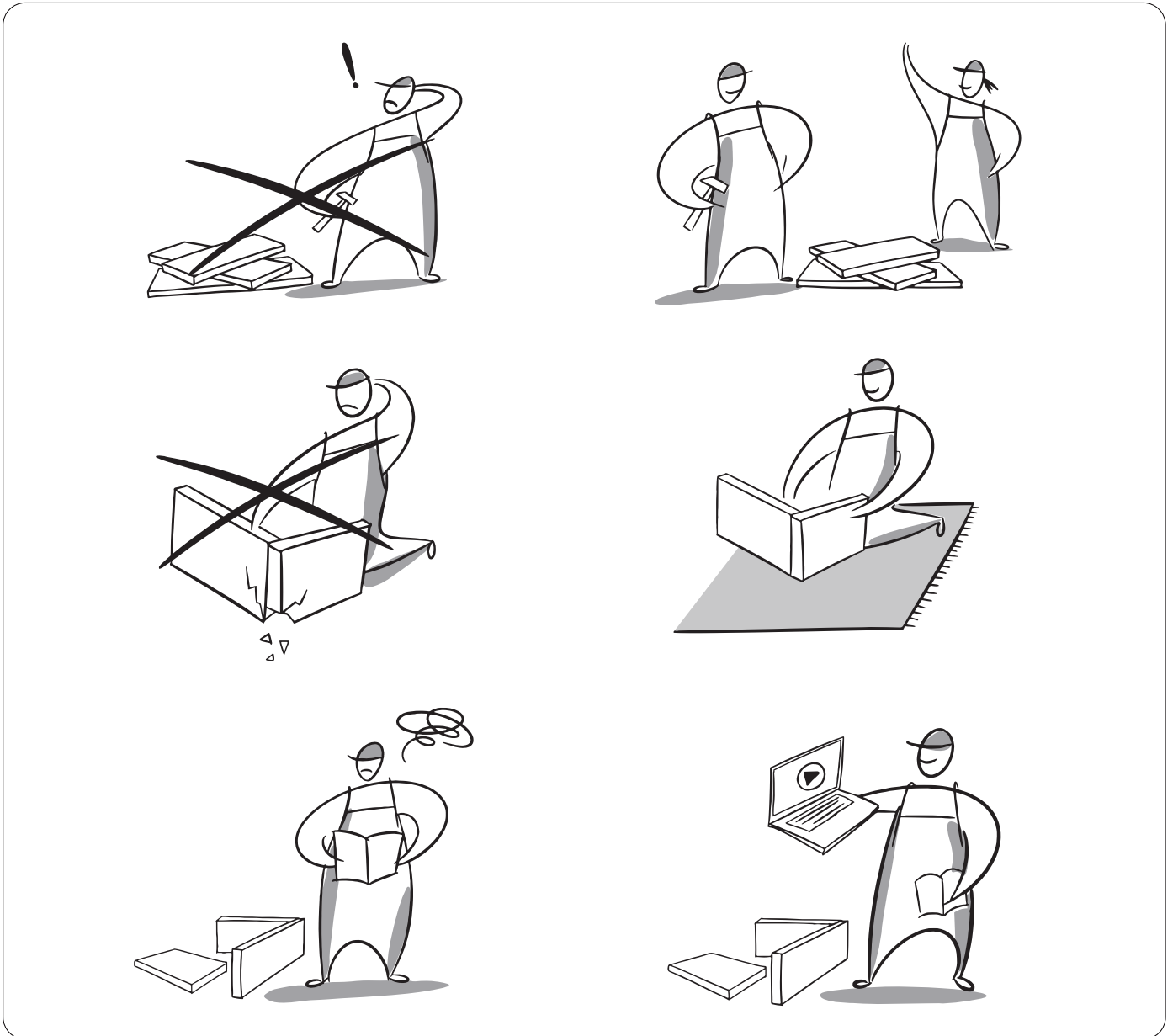

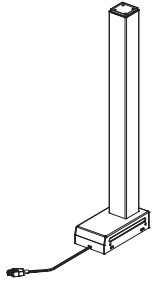

1 X1

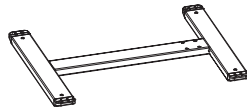

2 X1

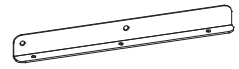

3 X1

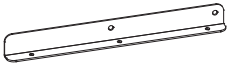

4 X1

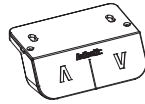

5 X1

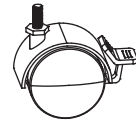

6 X4

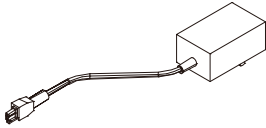

7 X1

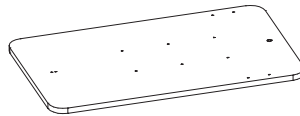

8 X1

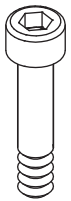

M6X32

A X4



M6X8

B X4



M6X10

C X1



ST4.8X13

D X10



M6X8

E X1

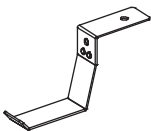

F X1

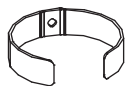

G X1



H X3

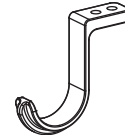

J X1



K X1

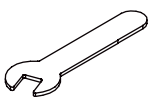

L X1

1

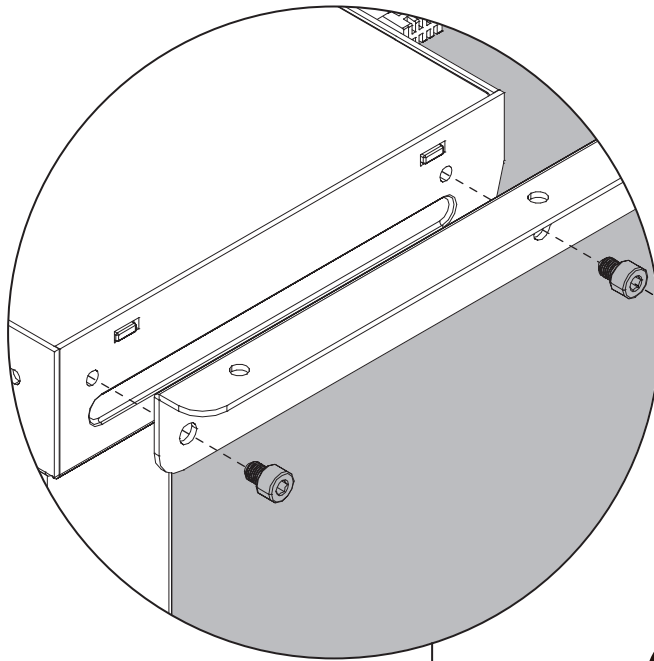

X4

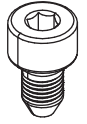

M6X8



B

3

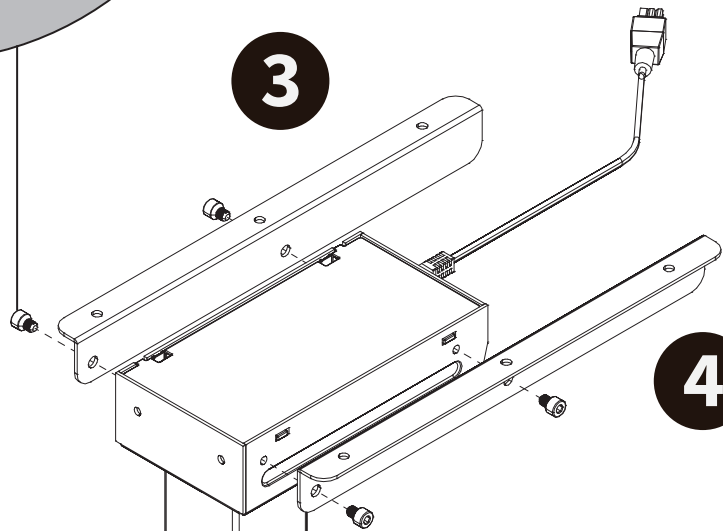

4

1

2

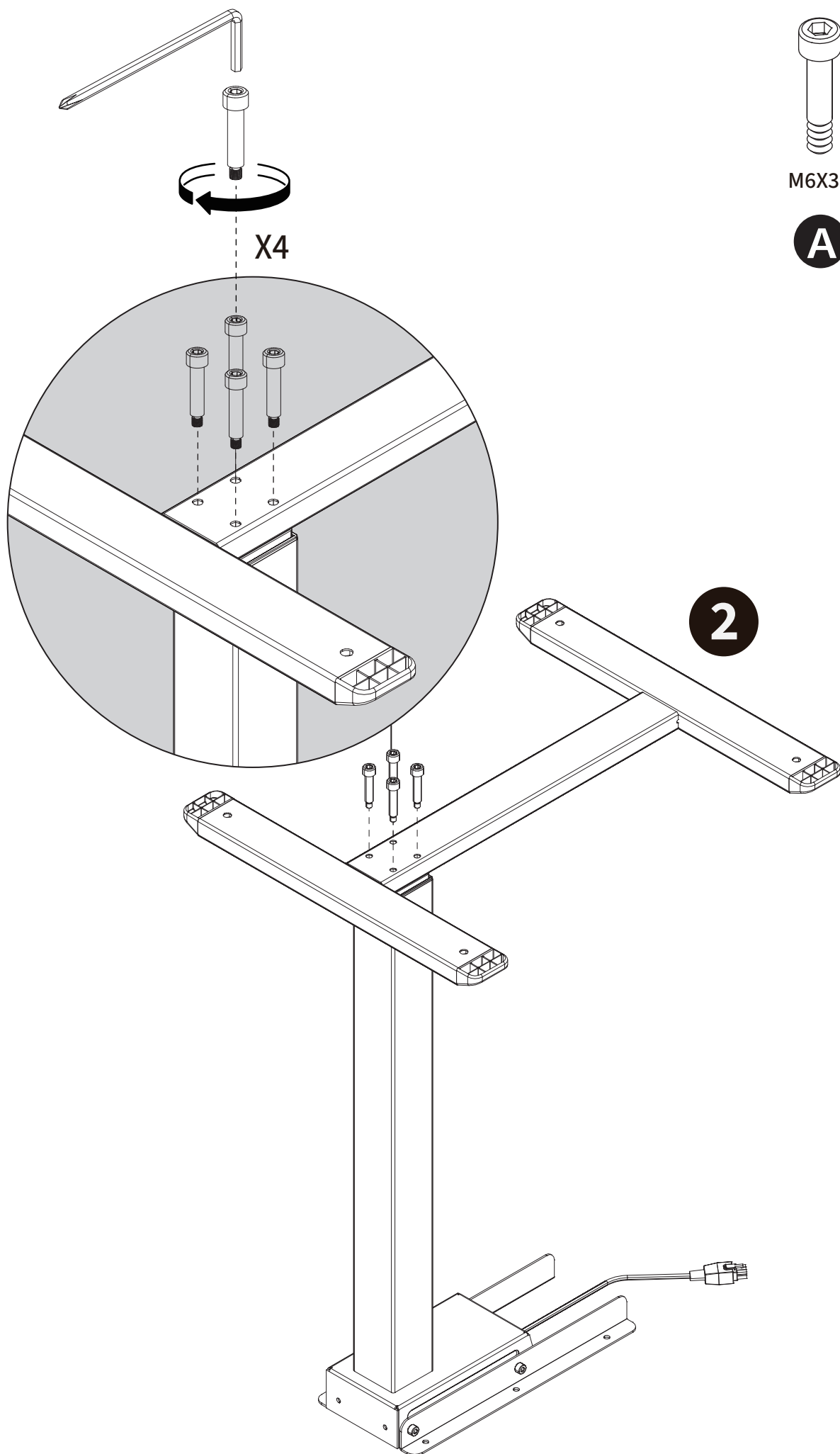

M6X32

A

2

3

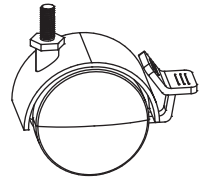

6

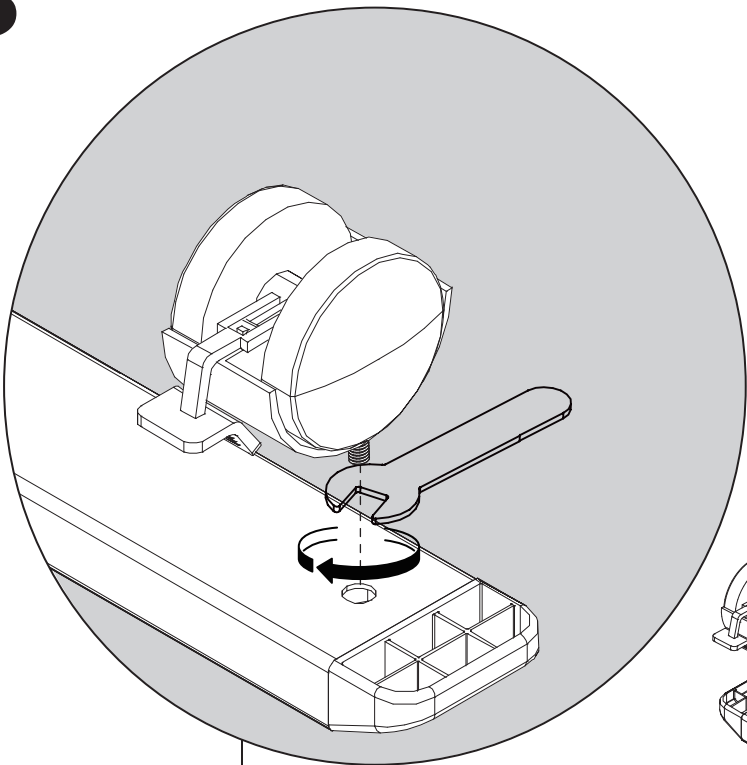

6

6

6

6

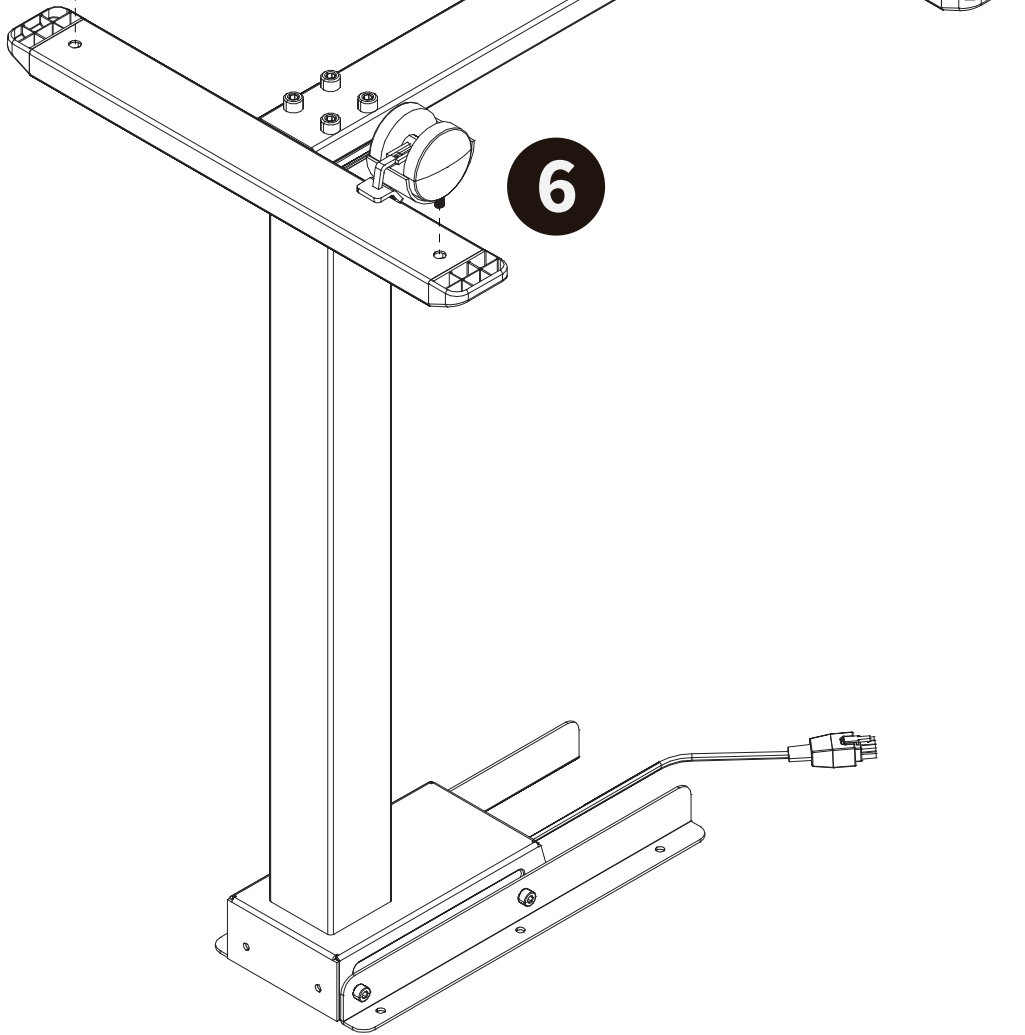

4

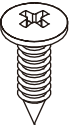

ST4.8X13

D

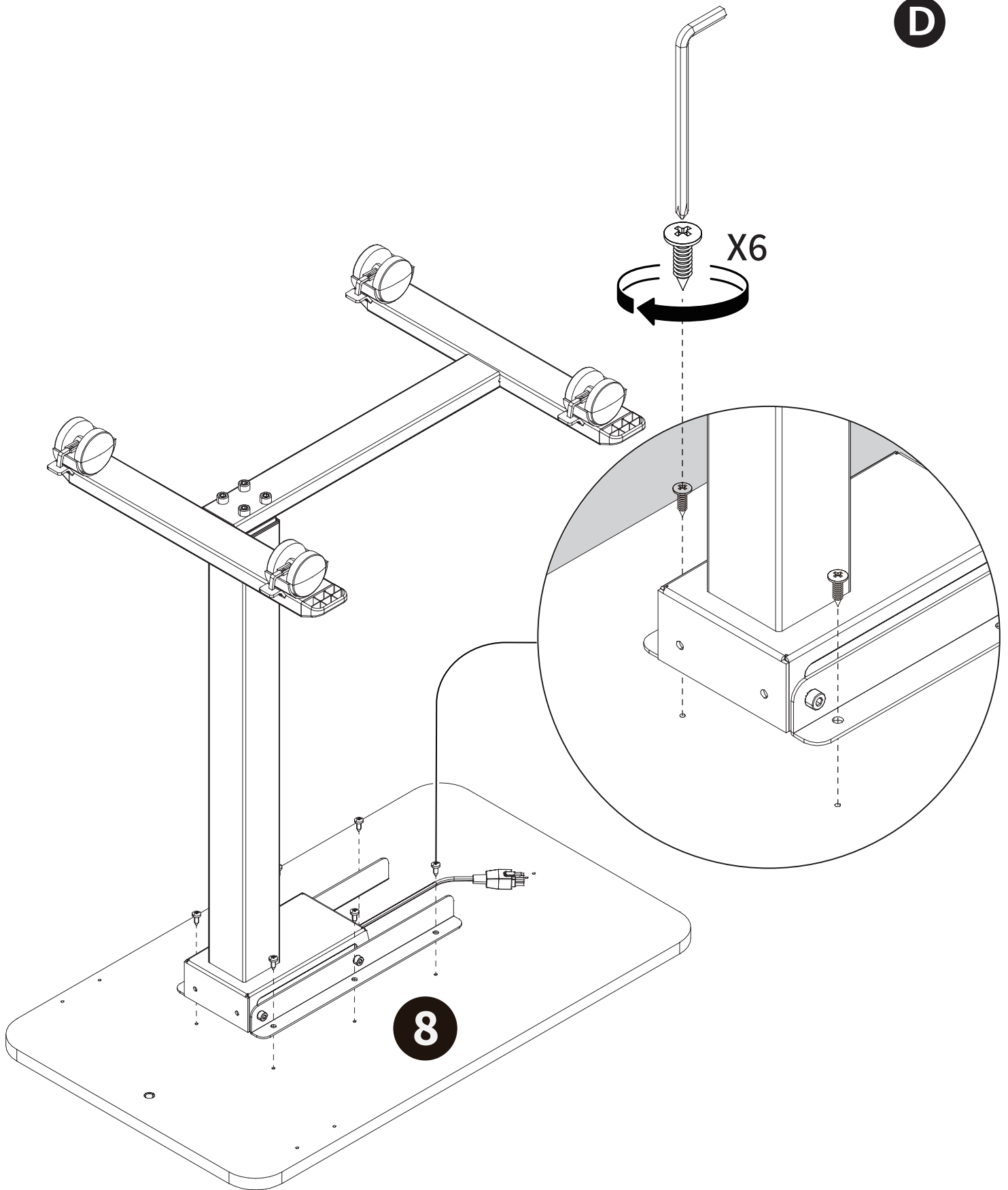

5

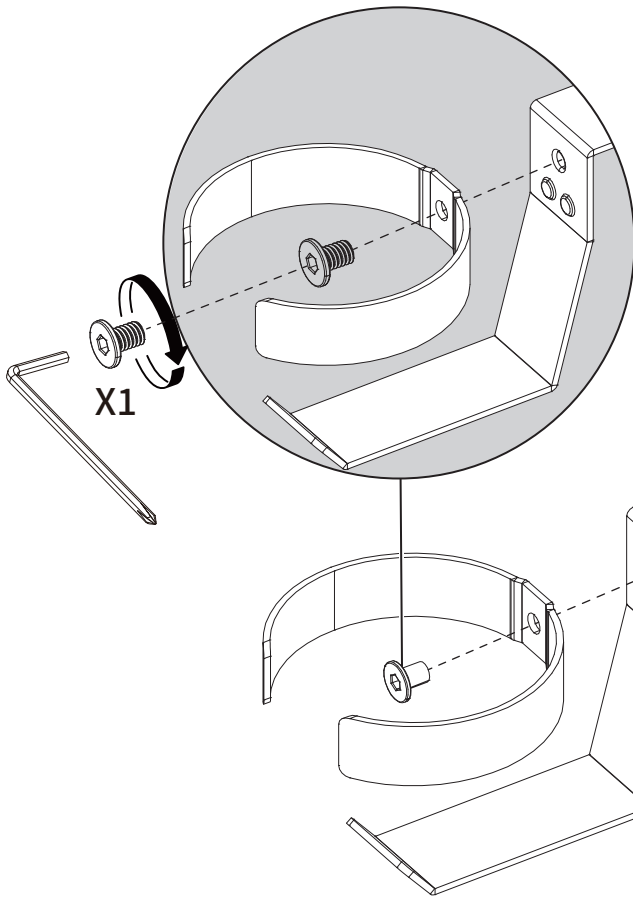

X1

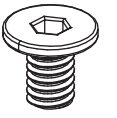

M6X10

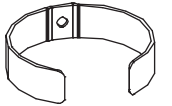
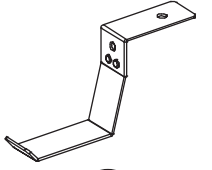

6

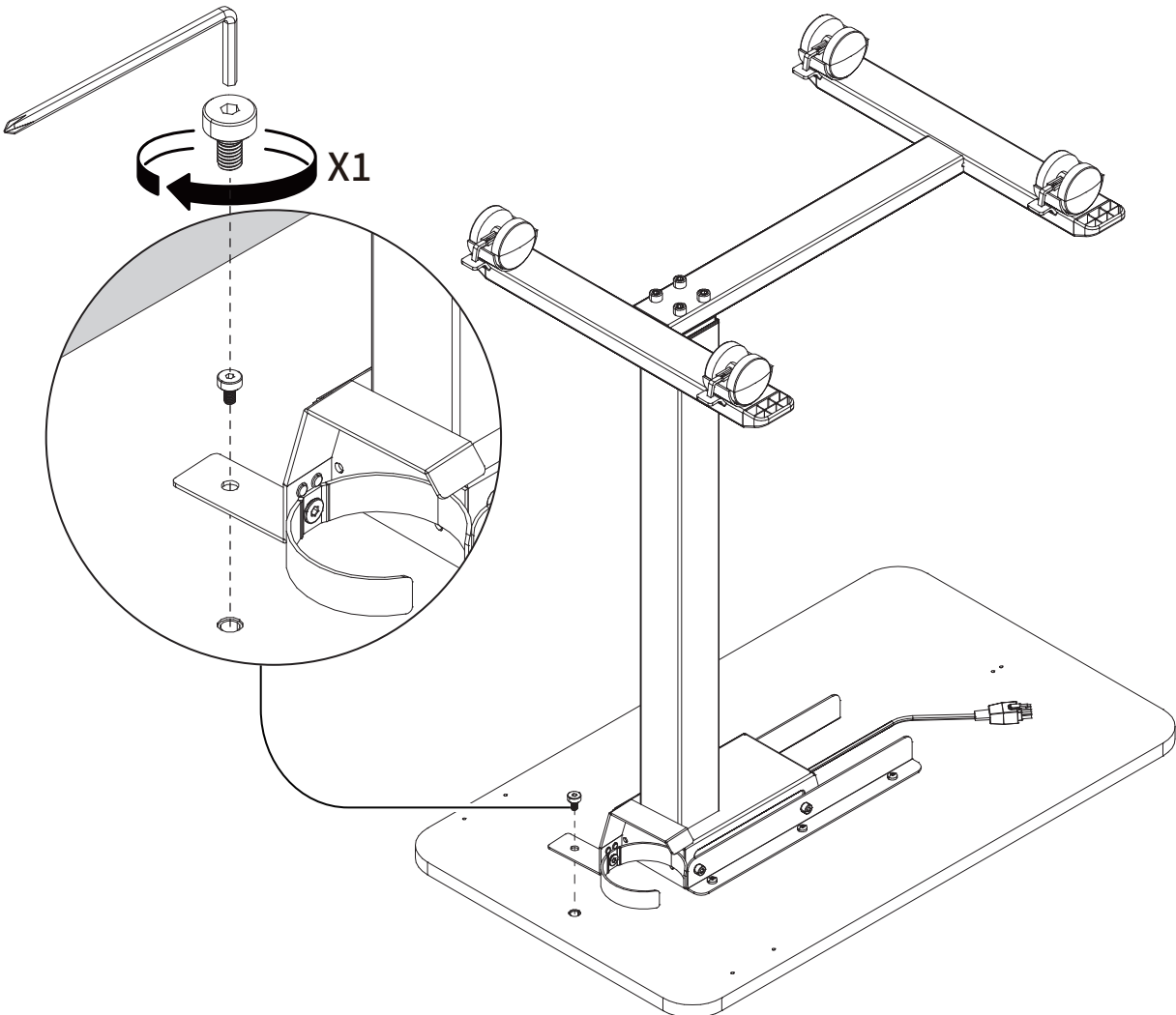

X1

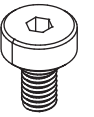

M6X8



7

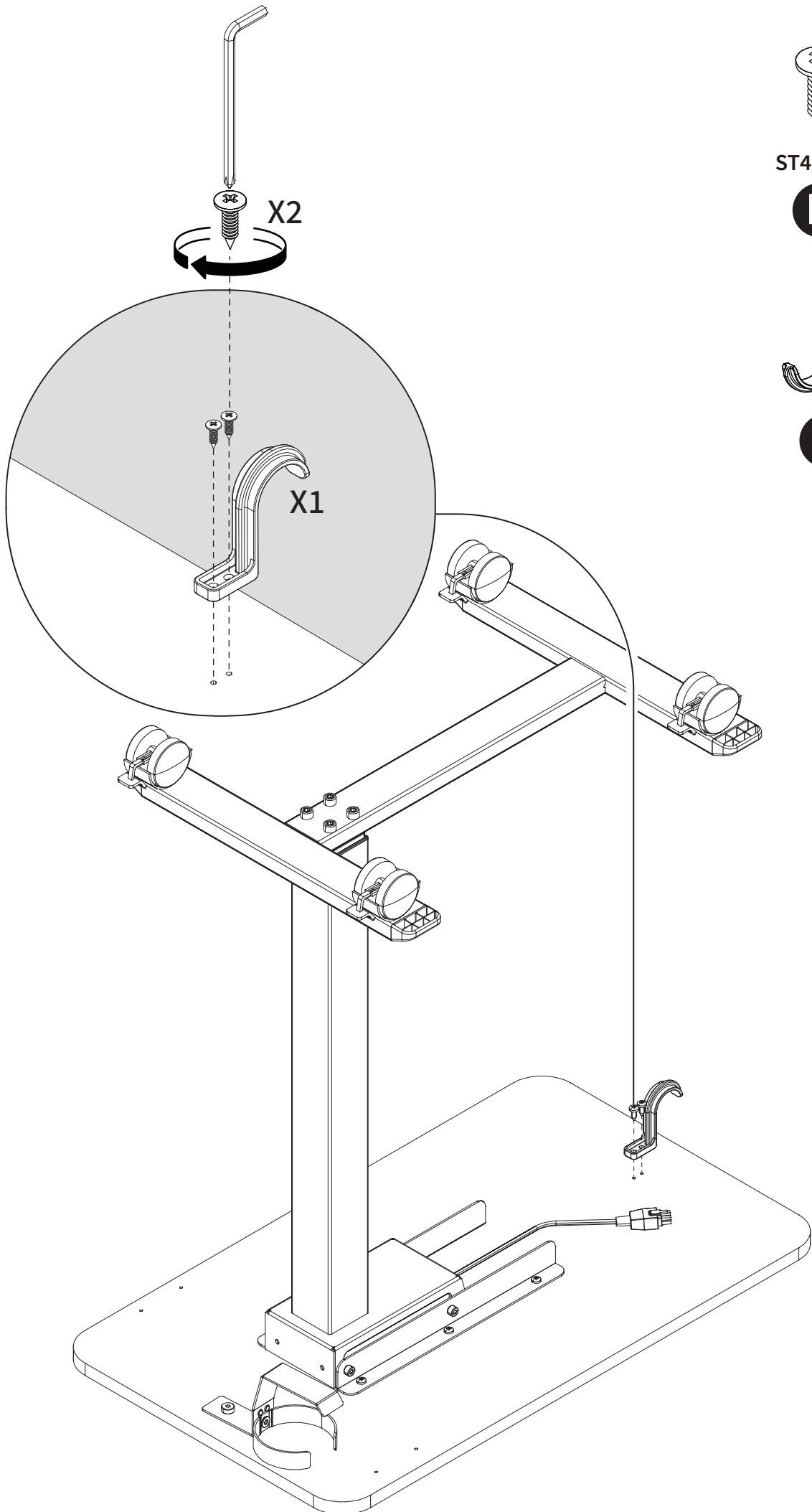

ST4.8X13

D

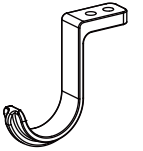

J

8



ST4.8X13

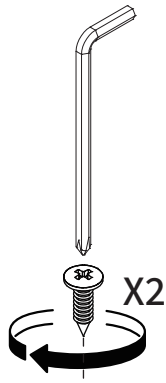

X2

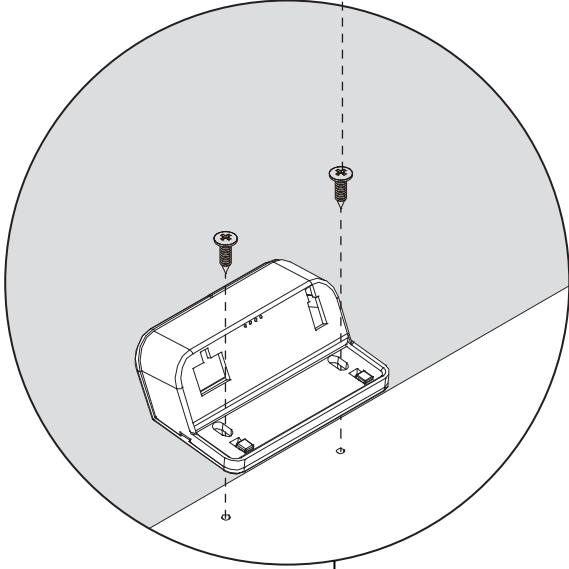

or

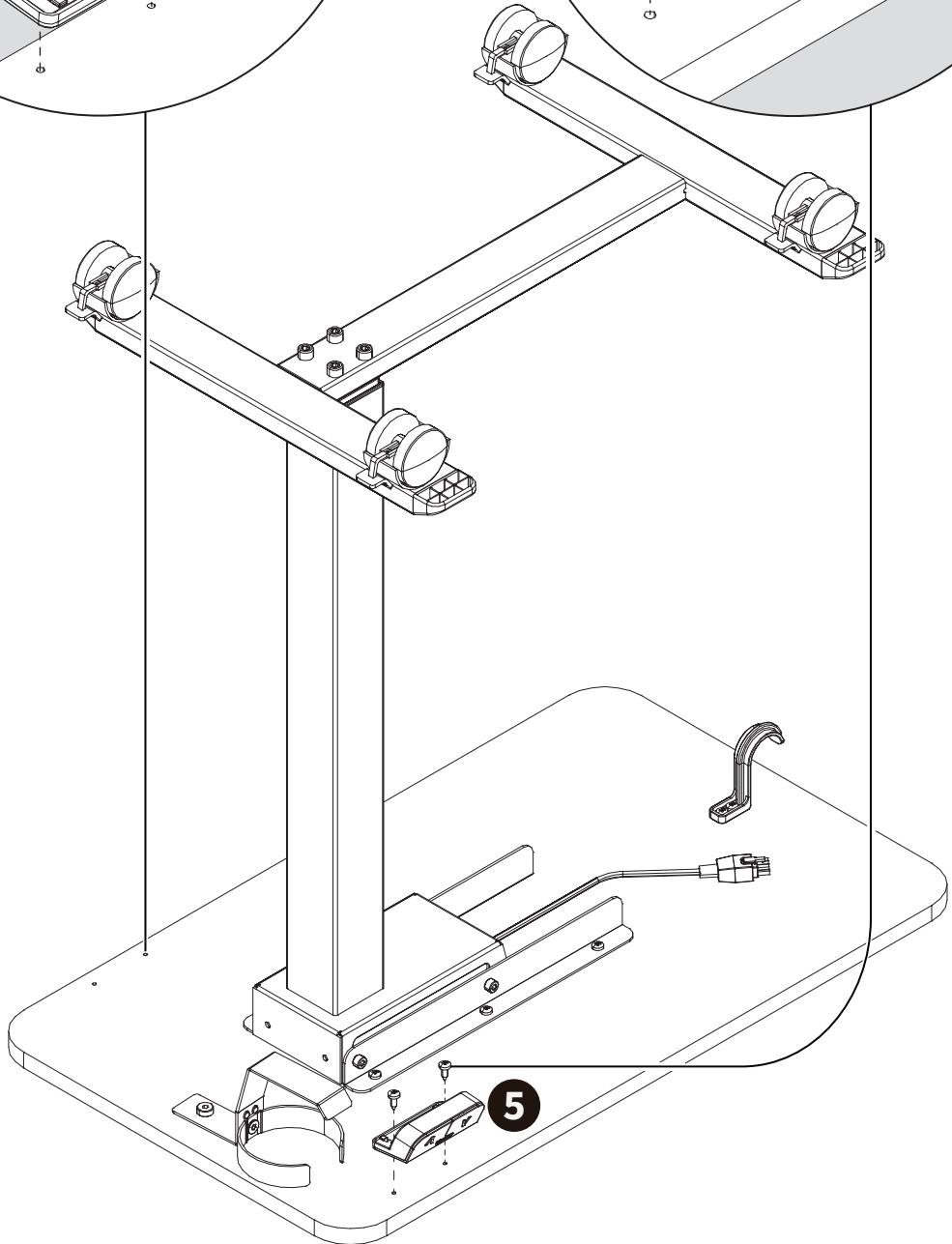
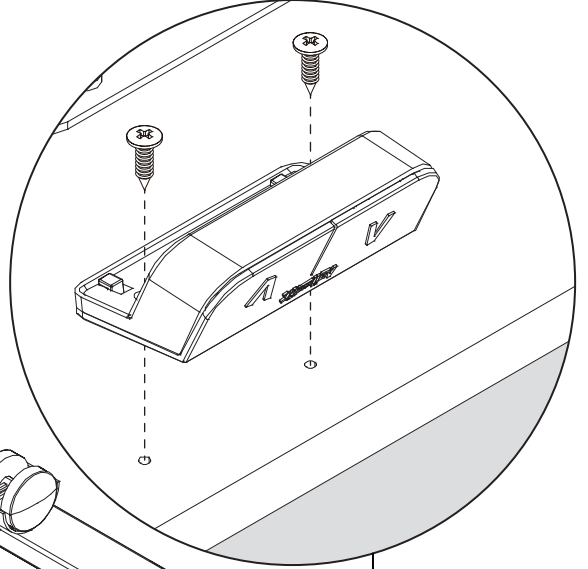

5

9

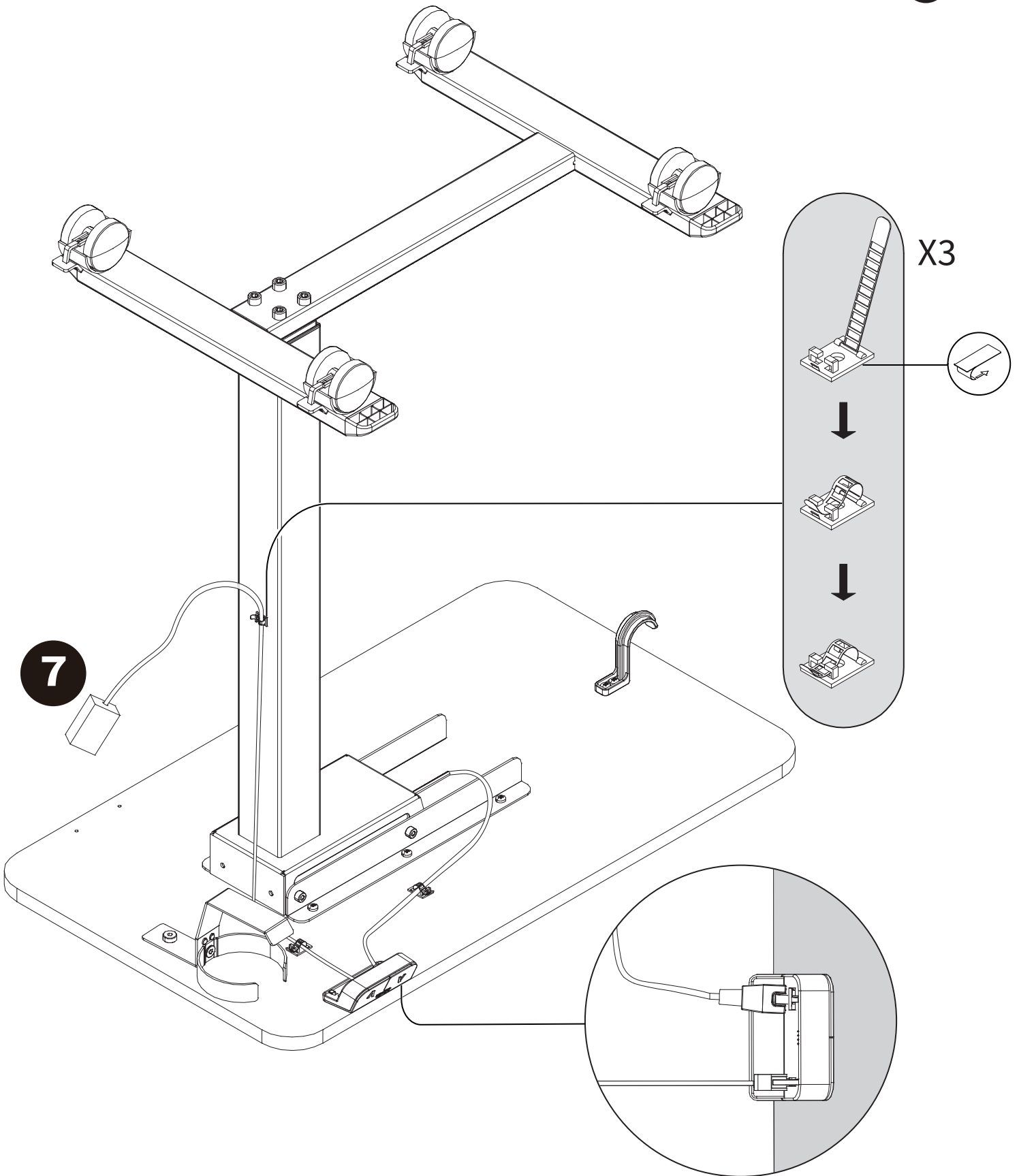
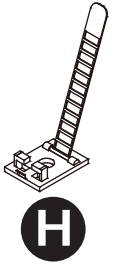

10



Controller Operation Instructions

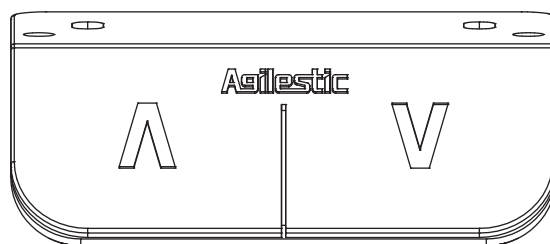

English(EN)
User Manual

Height Adjustment Operation	Press and hold the ▲ or ▼ key to control the rise or fall of the height-adjustable desk.
Reset to Factory Settings	Press and hold the ▲ and ▼ keys for more than three seconds until the red light flashes, then release the keys. The desk will automatically reset to its lowest position and complete initialization. At this point, the blue light will stay on.

Protection and Alarm

Normal Status	A steady blue light indicates that the system is functioning properly. The blue light flashes when the desk is moving.
Overheat Protection	The red light flashes slowly at 1.5-second intervals. This protection is activated after prolonged continuous operation. Reconnect the power or wait at least 18 minutes before using it again.
Overload Protection	The red light flashes rapidly at 0.5-second intervals. If this alarm occurs during operation, it indicates an overload. The desktop load should be reduced immediately.
Motor Error Protection	If the up or down button is pressed for 2 seconds and the red and blue lights flash alternately, it means the motor is not connected. Turn off the power, check, and ensure the motor is securely connected to the controller, then reconnect the power.
Anti-Collision Protection	When the height-adjustable desk encounters vibration, impact, or tilting during movement, the system will automatically trigger an alarm and immediately stop movement in the current direction. At the same time the desk will then reverse to a preset distance before the protection is deactivated. Ensure that the desk does not experience excessive vibration, collision with obstacles, or tilting before resuming operation.

Höhenverstellung	Halten Sie die ▲- oder ▼-Taste gedrückt, um den höhenverstellbaren Tisch steigen oder sinken zu lassen.
Werksreset	Halten Sie die ▲- und ▼-Tasten gleichzeitig für mehr als drei Sekunden gedrückt, bis die rote LED blinkt. Lassen Sie die Tasten los, und der Tisch fährt automatisch in die niedrigste Position zurück und initialisiert sich neu. Die blaue LED leuchtet dann dauerhaft.

Schutzfunktionen und Alarm

Normalbetrieb	Eine dauerhaft leuchtende blaue LED zeigt an, dass das System ordnungsgemäß funktioniert. Die blaue LED blinkt, wenn der Tisch bewegt wird.
Überhitzungsschutz	Die rote LED blinkt langsam im 1,5-Sekunden-Takt. Dieser Schutz wird nach längerem Dauerbetrieb aktiviert. Trennen Sie den Strom oder warten Sie mindestens 18 Minuten, bevor Sie den Tisch wieder nutzen.
Überlastschutz	Die rote LED blinkt schnell im 0,5-Sekunden-Takt. Wenn dieser Alarm während des Betriebs auftritt, liegt eine Überlast vor. Verringern Sie sofort die Belastung auf der Tischplatte.
Motorfehler-Schutz	Wenn die Auf- oder Ab-Taste 2 Sekunden gedrückt wird und die rote und blaue LED abwechselnd blinken, ist der Motor nicht angeschlossen. Schalten Sie den Strom aus, prüfen Sie die Verbindung zwischen Motor und Controller, und schalten Sie den Strom wieder ein.
Anti-Kollisionsschutz	Wenn der höhenverstellbare Tisch während der Bewegung Erschütterungen, Stöße oder Neigungen erfährt, löst das System automatisch einen Alarm aus und stoppt sofort die Bewegung. Der Tisch fährt dann automatisch eine voreingestellte Strecke zurück, bevor der Schutz deaktiviert wird. Stellen Sie sicher, dass keine starken Erschütterungen, Hindernisse oder Neigungen vorliegen, bevor Sie den Betrieb fortsetzen.

Réglage de la hauteur	Maintenez la touche ▲ ou ▼ enfoncée pour faire monter ou descendre le bureau réglable en hauteur.
Réinitialisation aux paramètres d'usine	Maintenez les touches ▲ et ▼ enfoncées pendant plus de trois secondes jusqu'à ce que le voyant rouge clignote, puis relâchez-les. Le bureau descendra automatiquement à sa position la plus basse et s'initialisera. Le voyant bleu restera alors allumé.

Protections et alarmes

État normal	Un voyant bleu fixe indique que le système fonctionne correctement. Le voyant bleu clignote pendant le mouvement du bureau.
Protection contre la surchauffe	Le voyant rouge clignote lentement toutes les 1,5 secondes. Cette protection s'active après une utilisation prolongée. Débranchez l'alimentation ou attendez au moins 18 minutes avant de réutiliser le bureau.
Protection contre la surcharge	Le voyant rouge clignote rapidement toutes les 0,5 seconde. Si cette alarme se déclenche, réduisez immédiatement la charge sur le plateau.
Protection contre les erreurs du moteur	Si les voyants rouge et bleu clignotent en alternance après avoir appuyé sur ▲ ou ▼ pendant 2 secondes, le moteur n'est pas connecté. Coupez l'alimentation, vérifiez la connexion du moteur au contrôleur, puis rallumez.
Protection anti-collision	Si le bureau rencontre des vibrations, chocs ou inclinaisons pendant son mouvement, le système déclenche une alarme et s'arrête immédiatement. Le bureau recule ensuite d'une distance prédéfinie avant la désactivation de la protection. Vérifiez l'absence d'obstacles avant de reprendre l'utilisation.

Regolazione dell'altezza	Tenere premuto il tasto ▲ o ▼ per alzare o abbassare la scrivania regolabile.
Ripristino delle impostazioni di fabbrica	Tenere premuti i tasti ▲ e ▼ per oltre 3 secondi finché la luce rossa lampeggia, poi rilasciarli. La scrivania tornerà automaticamente all'altezza minima e si reinizializzerà. La luce blu rimarrà accesa.

Protezioni e allarmi

Stato normale	Luce blu fissa = sistema funzionante. La luce blu lampeggia durante il movimento.
Protezione da surriscaldamento	Luce rossa lampeggiante lenta (ogni 1,5 secondi). Si attiva dopo uso prolungato. Scollegare l'alimentazione o attendere 18 minuti prima di riutilizzarla.
Protezione da sovraccarico	Luce rossa lampeggiante veloce (ogni 0,5 secondi). Ridurre immediatamente il carico sul piano..
Protezione da errore motore	Se i LED rosso e blu lampeggiano alternativamente dopo 2 secondi di pressione su ▲/▼, il motore non è collegato. Verificare la connessione e riaccendere.
Protezione anti-urto	In caso di vibrazioni, urti o inclinazione durante il movimento, la scrivania si ferma e retrocede automaticamente. Rimuovere eventuali ostacoli prima di riprendere.

Ajuste de altura	Mantenga pulsado el botón ▲ o ▼ para subir o bajar el escritorio regulable.
Restablecimiento de fábrica	Mantenga pulsados los botones ▲ y ▼ durante más de 3 segundos hasta que la luz roja parpadee, luego suéltelos. El escritorio descenderá automáticamente a su posición más baja y se reinicializará. La luz azul permanecerá encendida.

Protecciones y alarmas

Estado normal	Una luz azul fija indica que el sistema funciona correctamente. La luz azul parpadea durante el movimiento.
Protección por sobrecalentamiento	La luz roja parpadea lentamente (cada 1,5 segundos). Se activa tras un uso prolongado. Desconecte la alimentación o espere 18 minutos antes de volver a usarlo.
Protección por sobrecarga	La luz roja parpadea rápidamente (cada 0,5 segundos). Si ocurre, reduzca inmediatamente la carga en la mesa.
Protección por error del motor	Si las luces roja y azul parpadean alternativamente tras pulsar ▲/▼ durante 2 segundos, el motor no está conectado. Apague el equipo, revise la conexión y vuelva a encenderlo.
Protección anti-colisión	Si el escritorio detecta vibraciones, golpes o inclinación durante el movimiento, se detendrá y retrocederá una distancia preestablecida. Asegúrese de que no haya obstáculos antes de continuar.