

Assembly Instructions

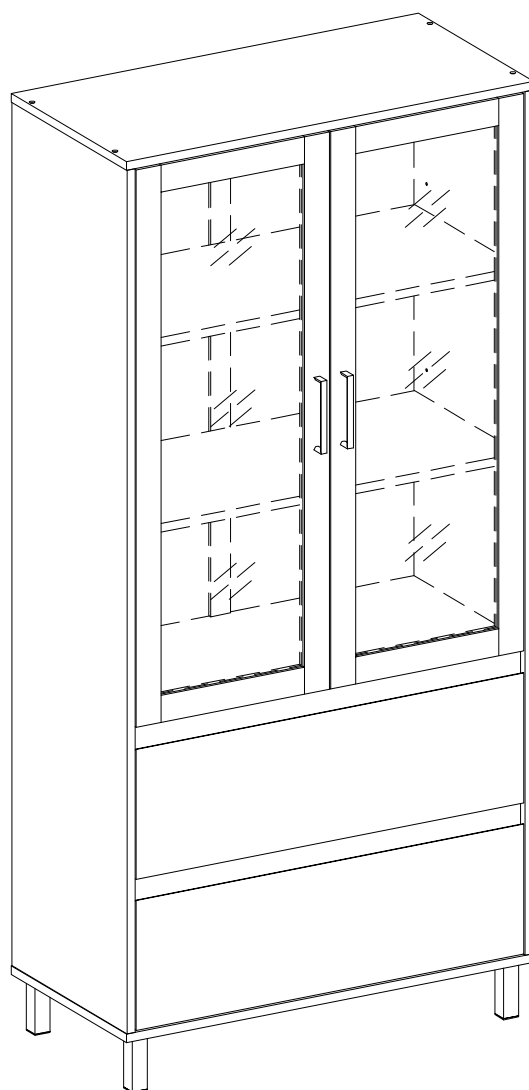

General Assembly Guidelines

- I. Ensure that all parts and hardware are available before beginning assembly.
- II. Follow each step carefully to ensure the proper assembly of this product.
- III. Two people are recommended for ease in the assembly of this product.
- IV. The three main types of hardware used to assemble this product are : wood dowels , screws and bolts.
- V. The provided glue is to secure wood dowels in place . When first inserting dowels , locate the appropriate hole for the dowel , place a small amount of glue in the hole and insert the dowel . Wipe away excess glue immediately.

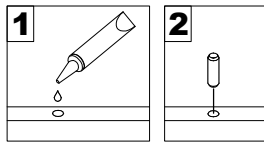

In future assembly steps when dowels are necessary to attach assembly parts together , place a small amount of glue on the end of the dowel before attaching parts together . Wipe away excess glue immediately.

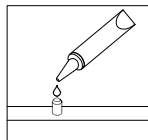

- VI. A Phillips head screwdriver is required for the assembly of this product .

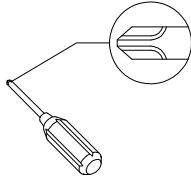

- VII. Power tools should not be used to assemble this product .

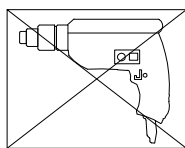

- VIII. Concealed hinges are three-way adjustable.

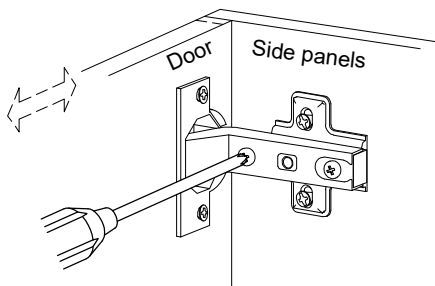

Horizontal
by screw adjustment

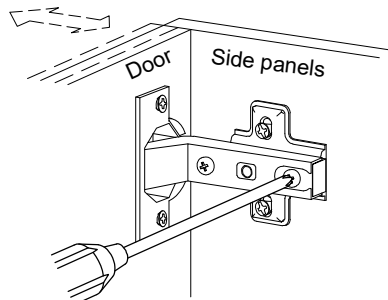

In-and-Out
by loosening the hinge-arm
mounting screw or via cam
adjustment

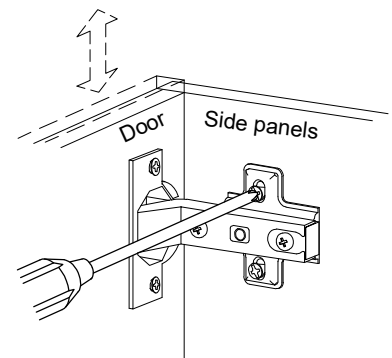





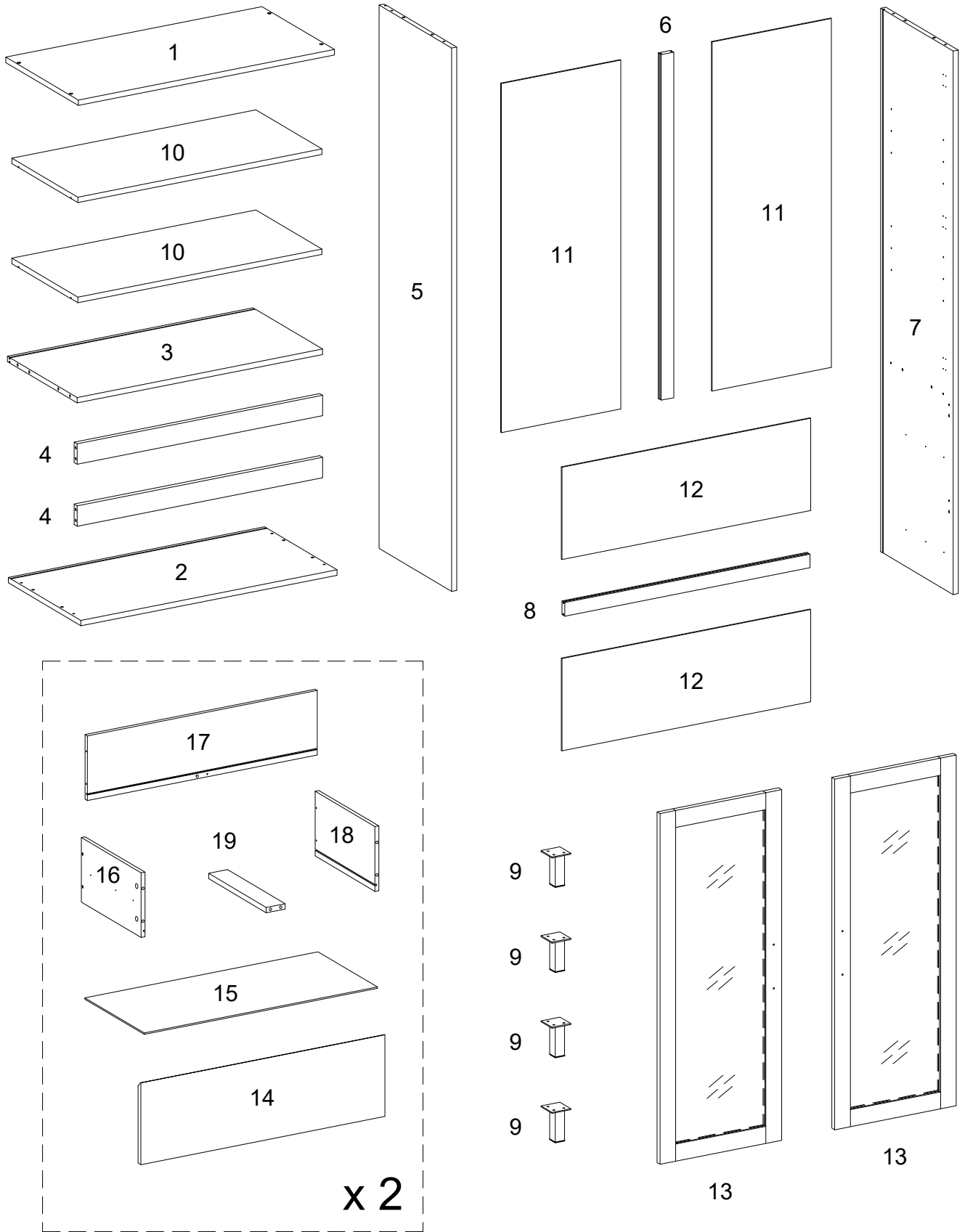



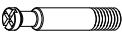

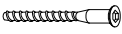

Vertical
Via slots in the mounting
plate or via cam adjustment

Parts List

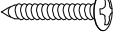

Hardware List

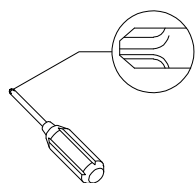

A		Ø8x30mm	Wooden dowel	20	pcs
B		Ø6x35mm	Cam bolt	18	pcs
C		Ø15x11mm	Cam lock	10	pcs
D		Ø15x9mm	Cam lock	8	pcs
E			Sticker	18	pcs
F		Ø6x30mm	Screw	4	pcs
G		Ø6x50mm	Screw	4	pcs
H		Ø6x12mm	Bolt	12	pcs
J		M4	Hex Key	1	pc
K			Shelf support pin	8	pcs
L			Handle	2	pcs
M		Ø4x22mm	Handle Bolt	4	pcs
N			Europe hinge	6	pcs
P		Ø3.5x14mm	Screw	36	pcs
Q			Plastic wedge	14	pcs
R		Ø3x17mm	Screw	14	pcs
S		Ø4x12mm	Screw	2	pcs
T		Ø4x25mm	Screw	2	pcs
U			Plastic strap	2	pcs
V			Nut	2	pcs
W		Ø4x32mm	Screw	10	pcs



Philips head screwdriver required for assembly
(not included)

*The hardware quantities listed above are required for proper assembly.
Some extra hardware may also have been included.*

Hardware List

X			Glue tube	1	pc
Y		Ø3x12mm	Screw	24	pcs
Z			Drawer slider	2	sets

*Note: This piece comes preassembled for shipping purposes and must be disassembled to complete the desk assembly.

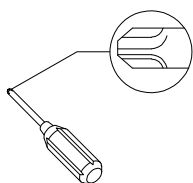

Philips head screwdriver required for assembly
(not included)

*The hardware quantities listed above are required for proper assembly.
Some extra hardware may also have been included.*

Step 1

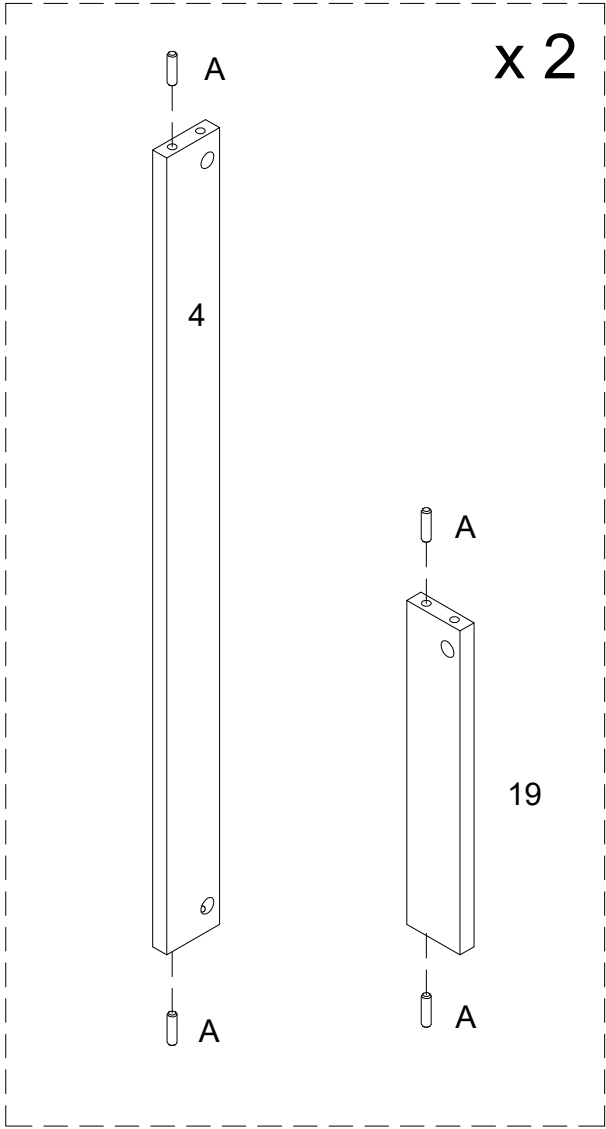
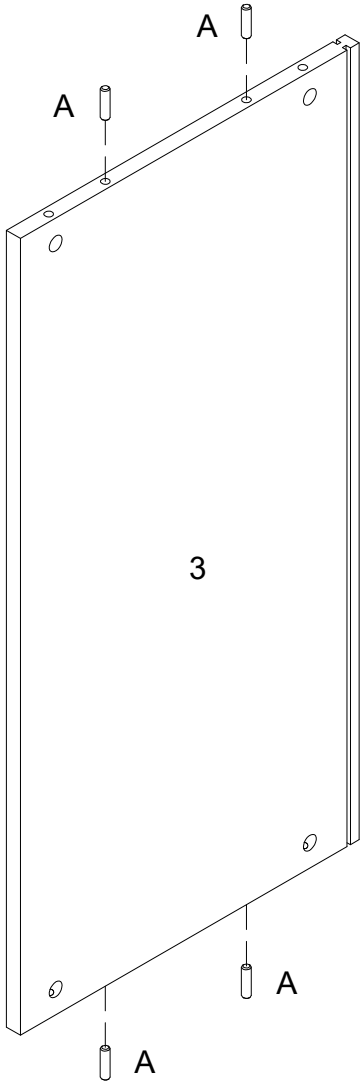

Insert wooden dowel (A) into parts (3,4,19) as per diagram.

Step 2

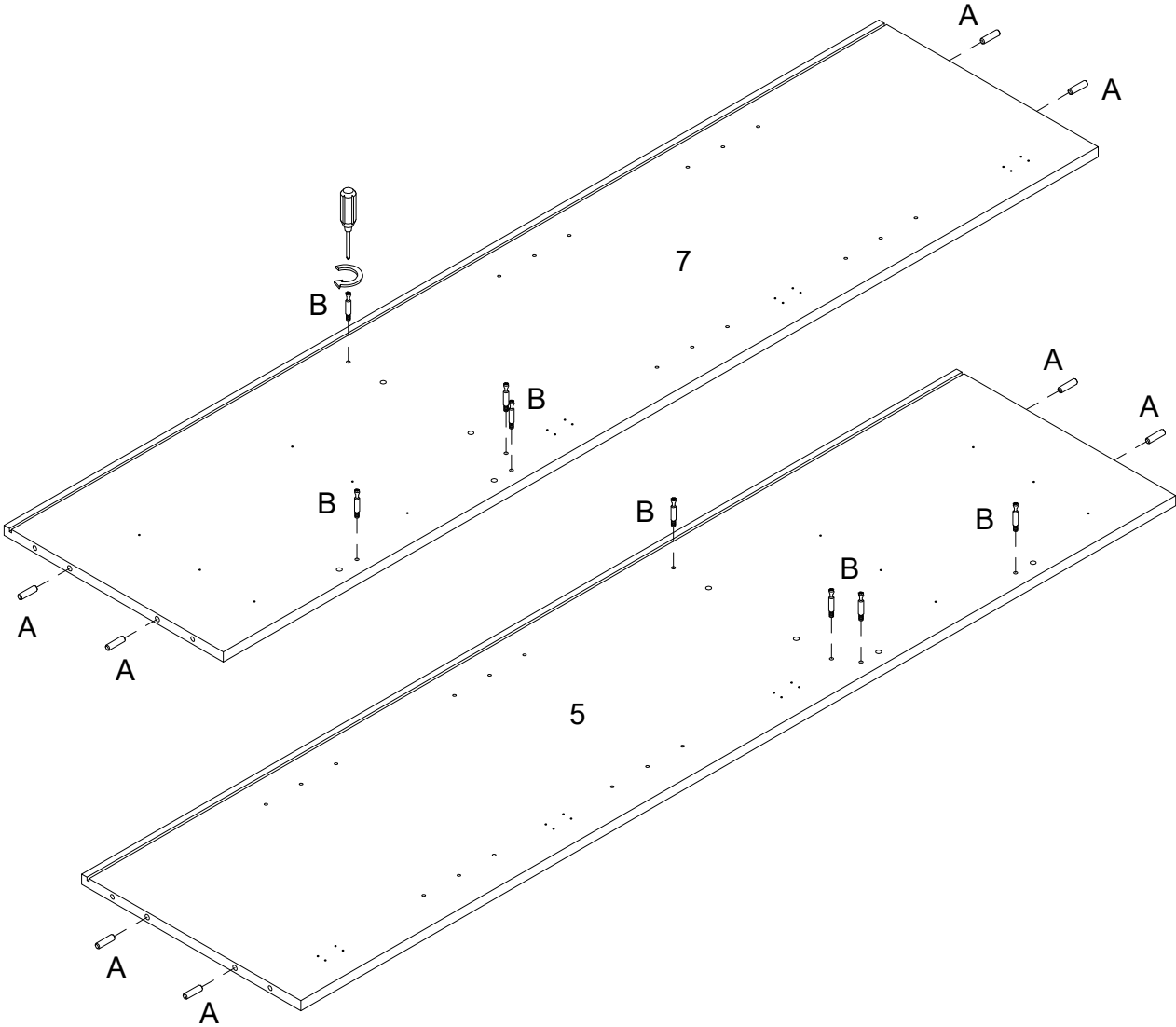

Insert wooden dowel (A) into parts (5,7) , then secure cam bolt (B) into parts (5,7) with Philips head screwdriver as per diagram.

Step 3

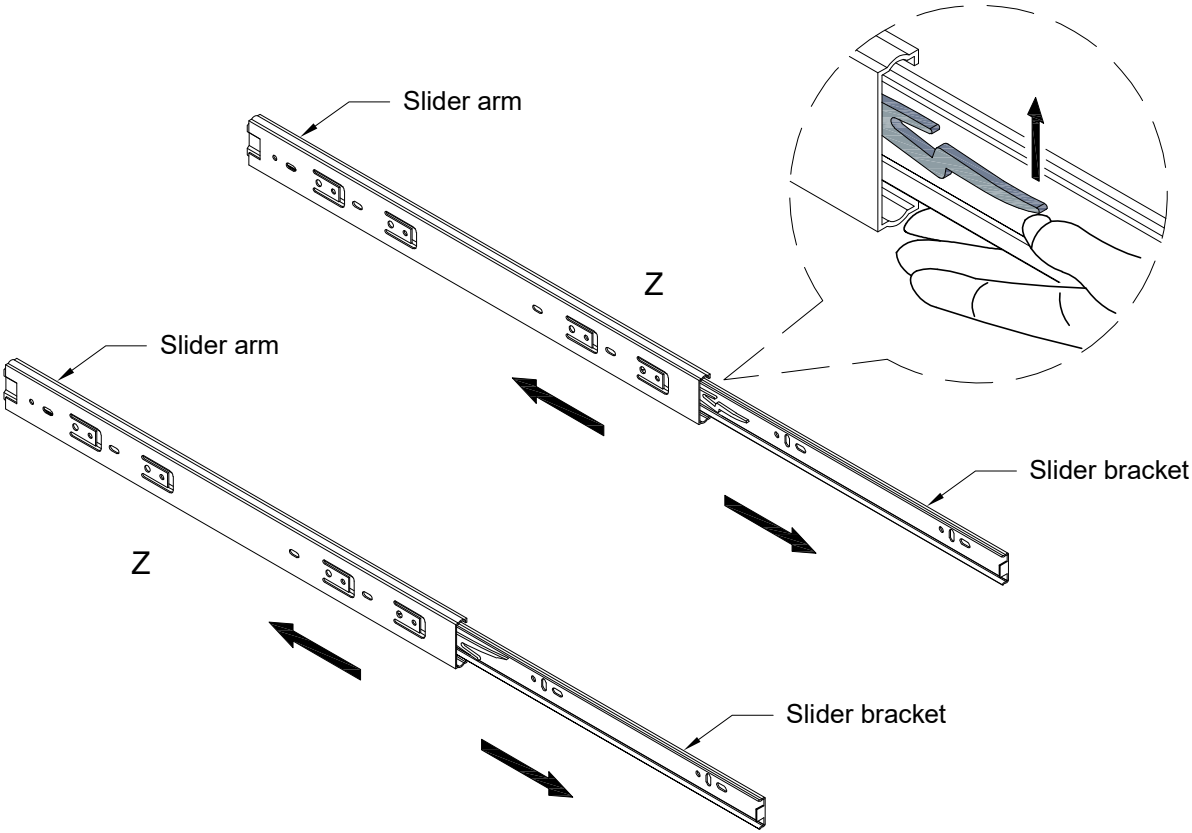

Separate the slide bracket from the slide arm as per diagram.

Step 4

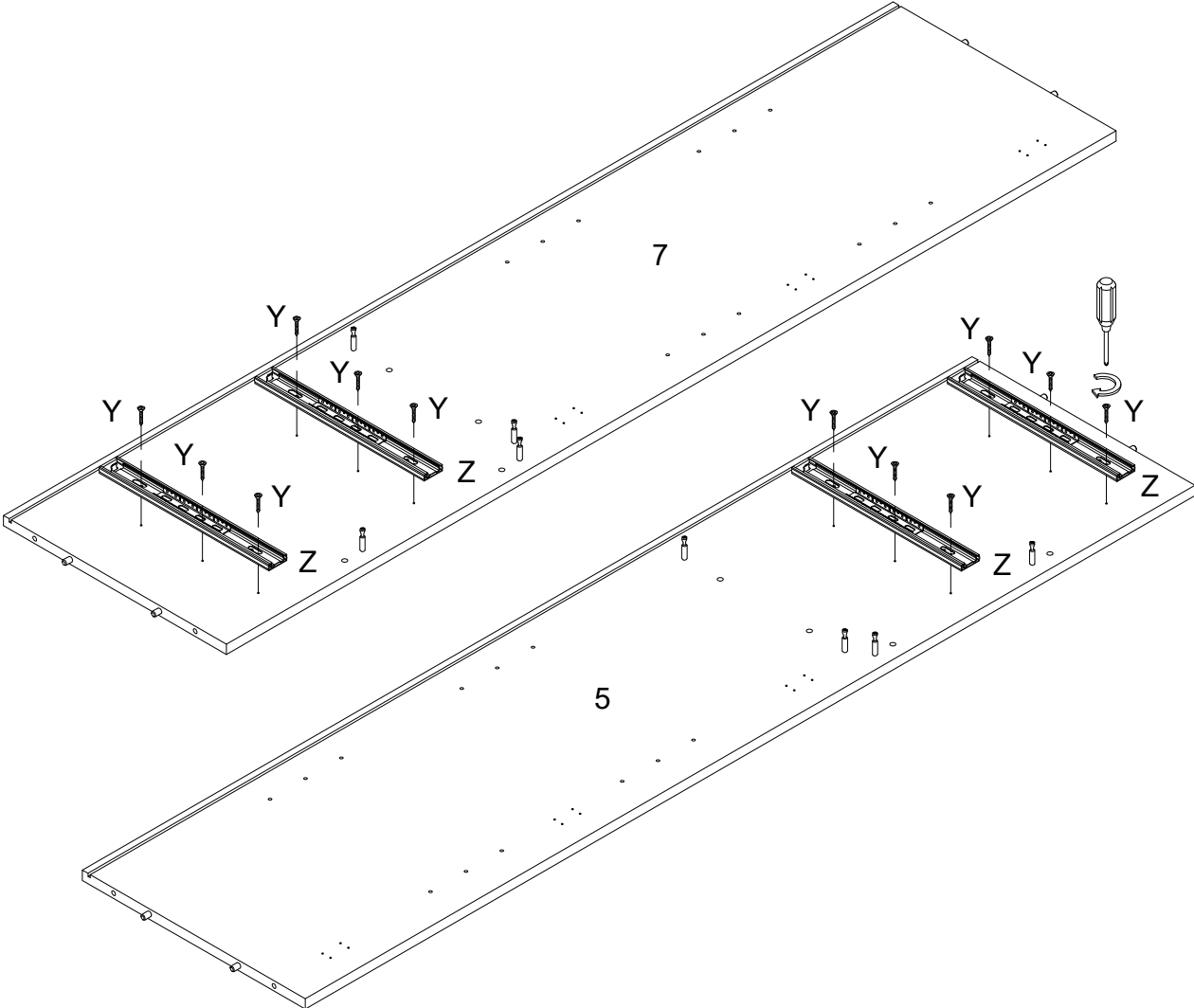

Using screw(Y) secure drawer slider arm (Z) to parts (5,7) with Philips head screwdriver as per diagram.

Step 5

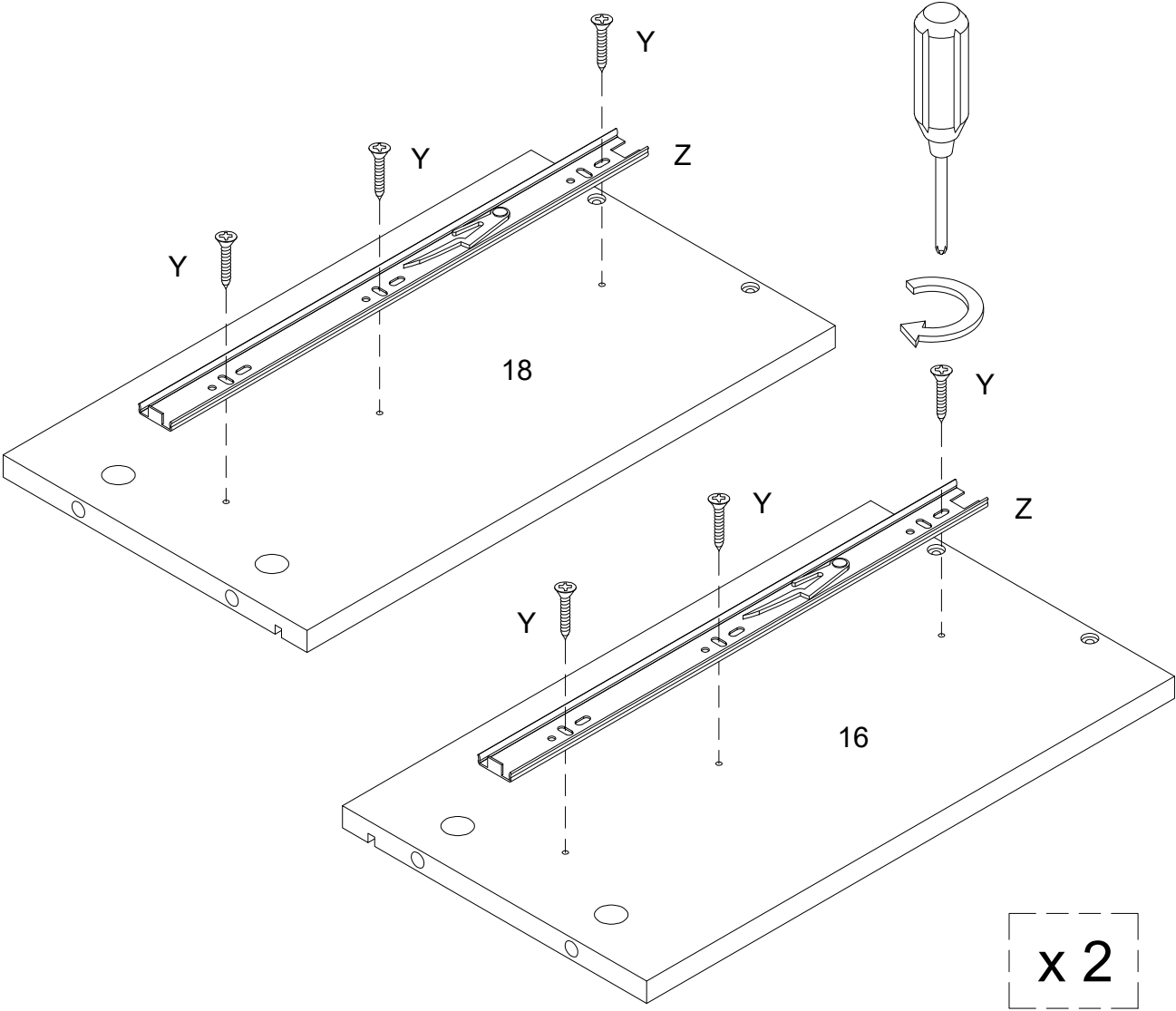

Using screw(Y) secure drawer slider bracket (Z) to parts (16,18) with Philips head screwdriver as per diagram.

Step 6

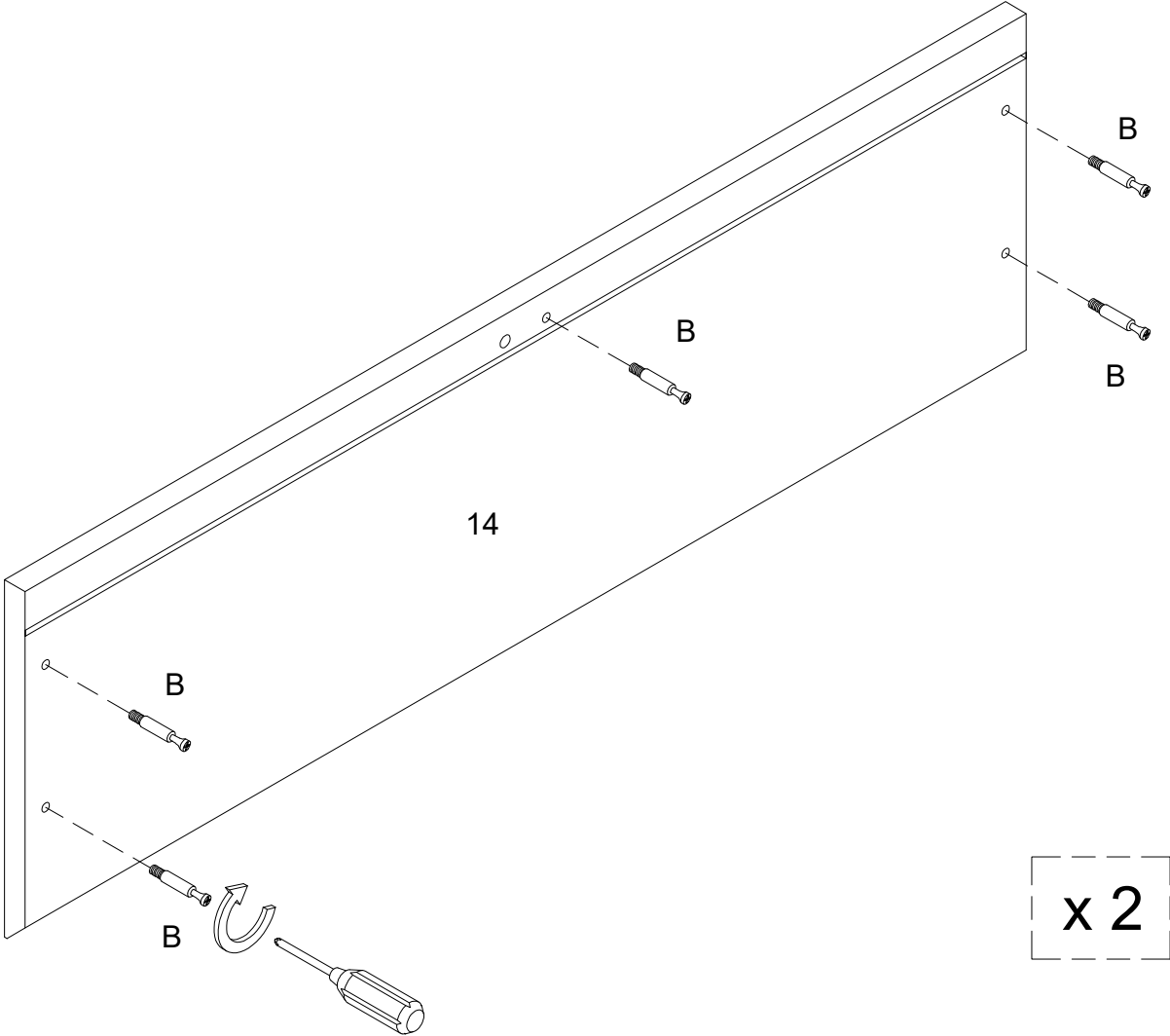

Secure cam bolt (B) into part (14) with Philips head screwdriver as per diagram.

Step 7

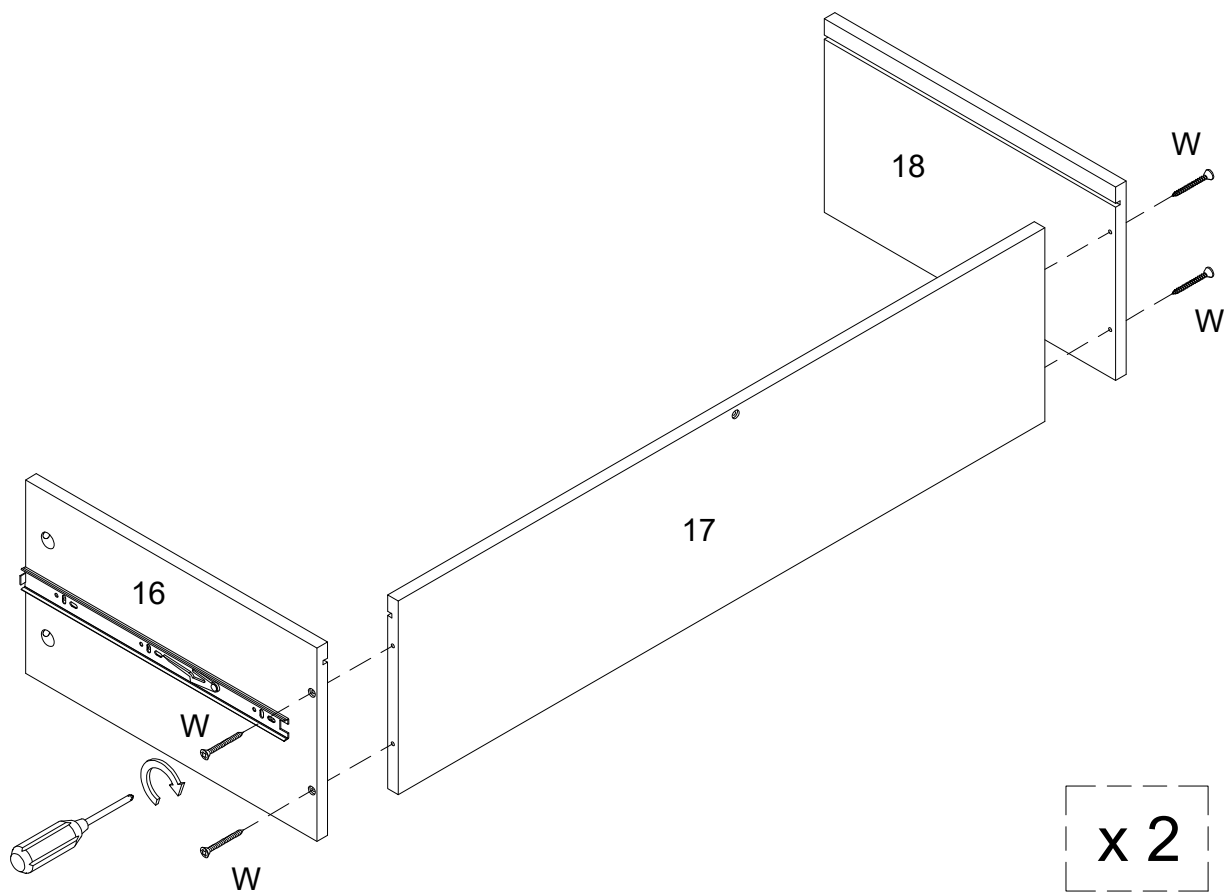

Using screw (W) attach parts (16,18) to part (17) with Philips head screwdriver as per diagram.

Step 8

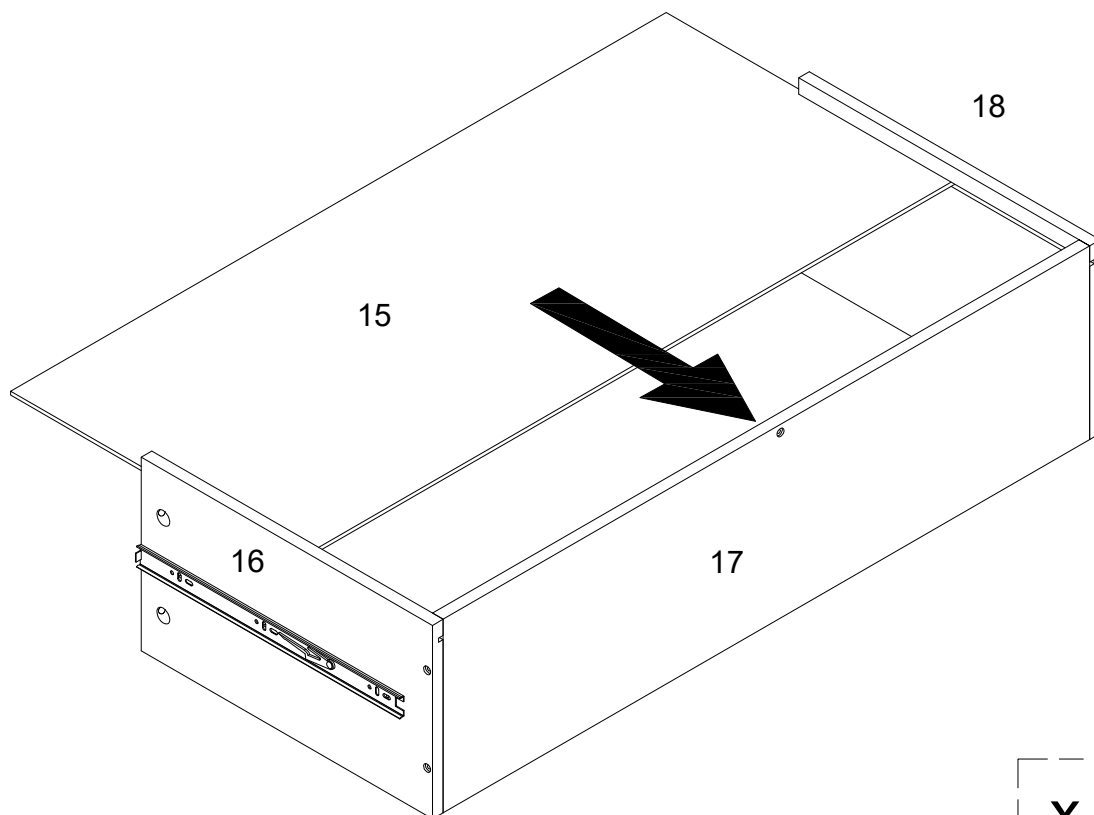

x 2

Put part (15) as per diagram.

Step 9

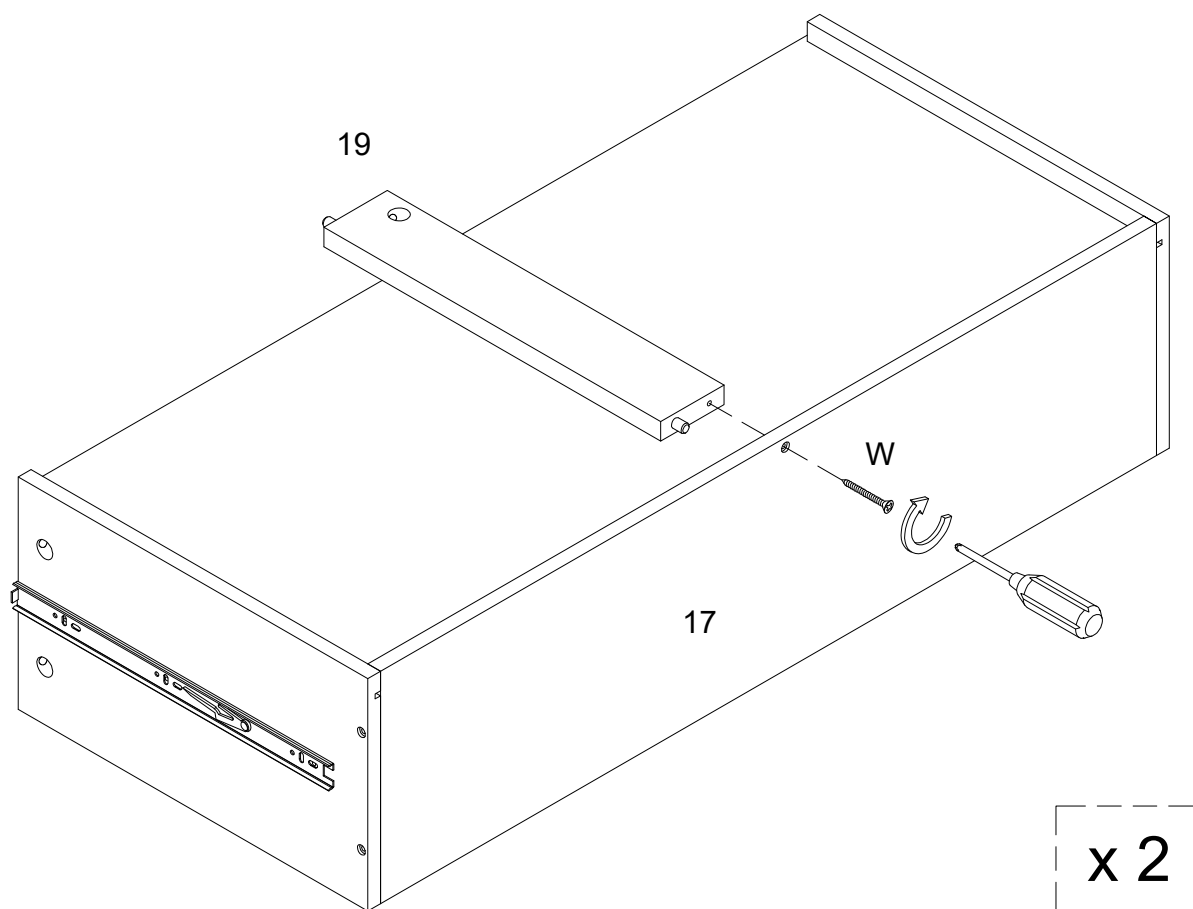

Using screw (W) attach part (17) to part (19) with Philips head screwdriver as per diagram.

Step 10

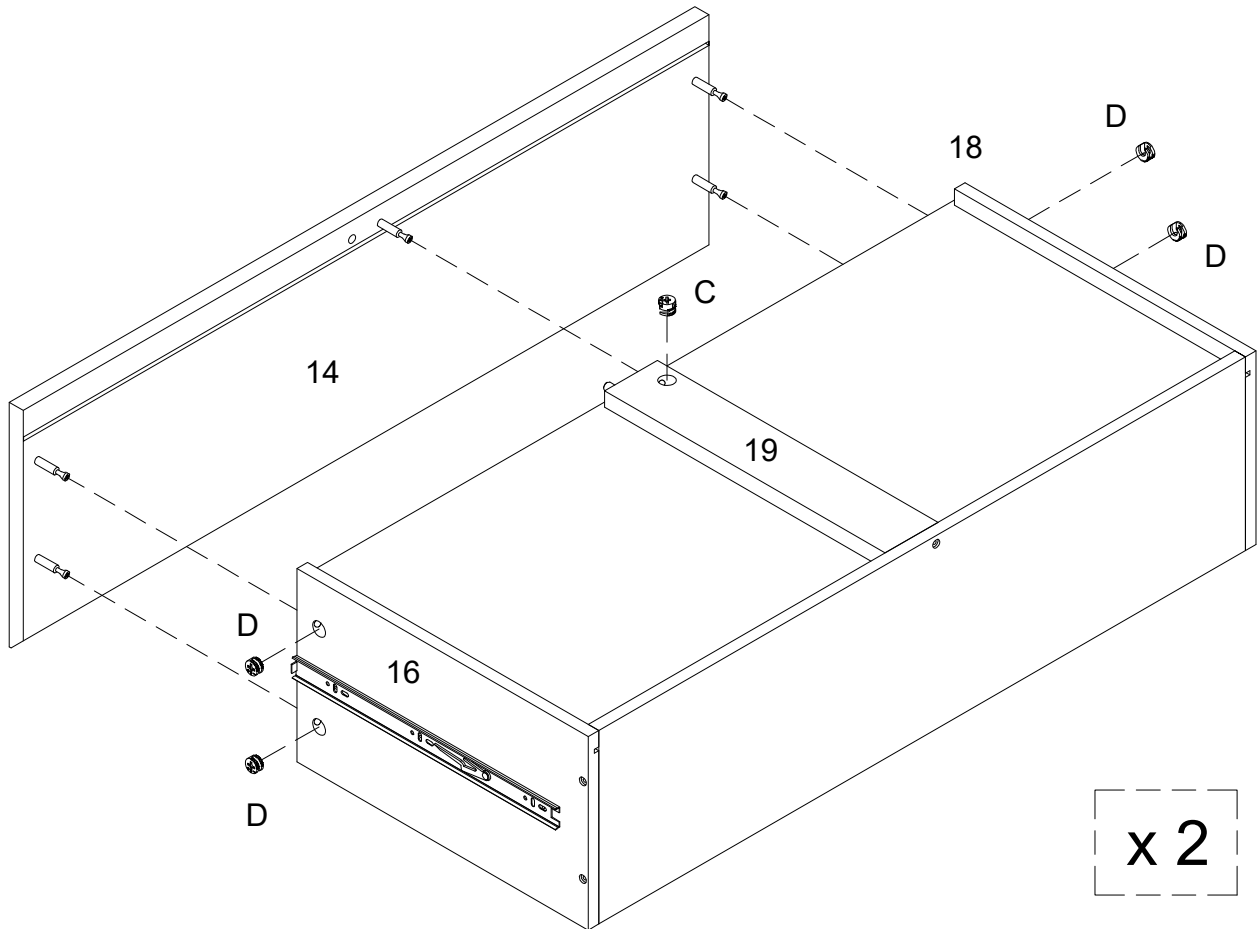
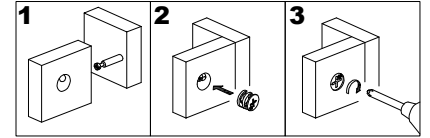

Using cam lock(D) secure part (14) to parts (16,18) ,cam lock (C) secure part (14) to part (19) with Philips head screwdriver as per diagram.

Step 11

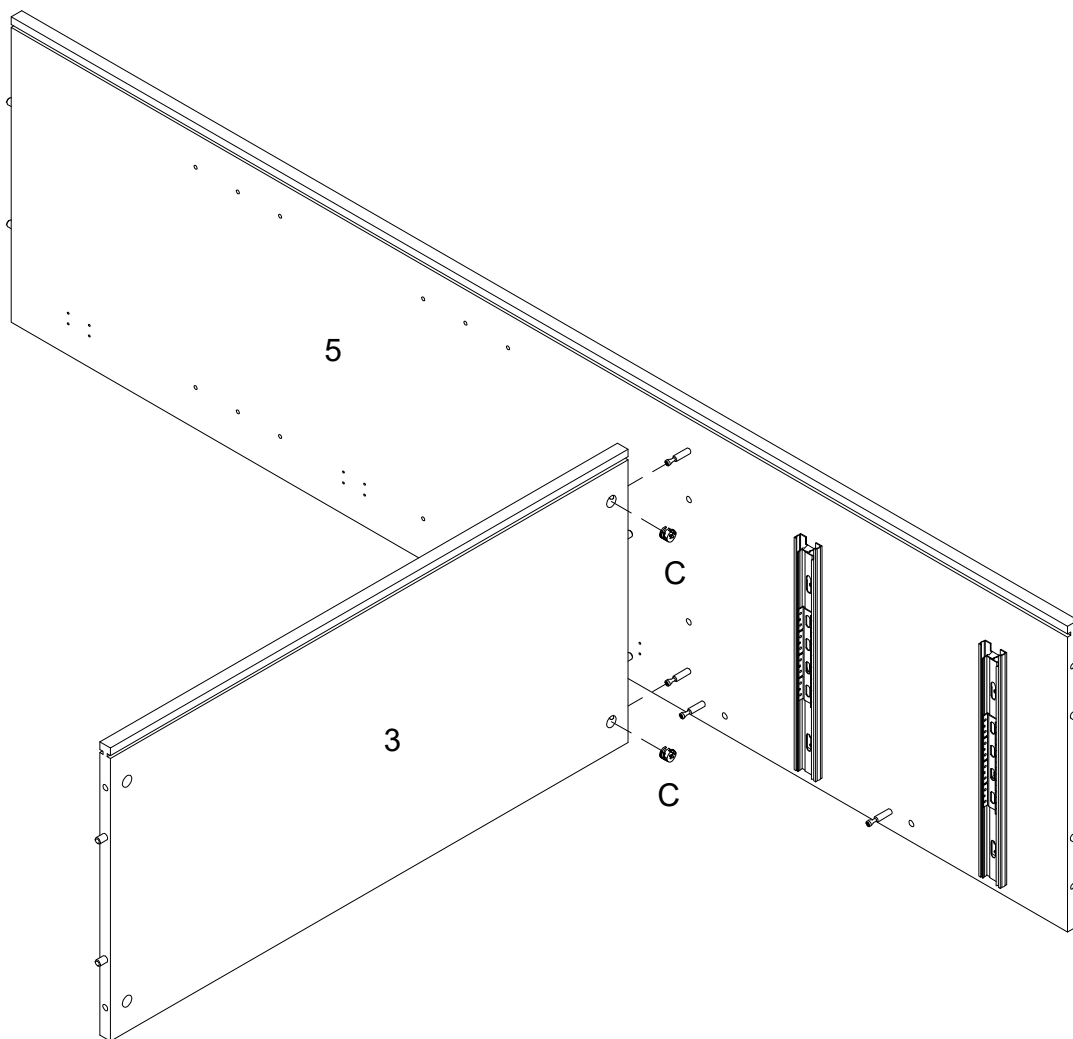
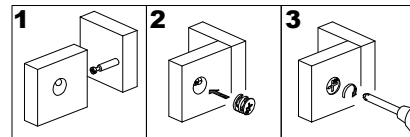

Using cam lock(C) secure part (3) to part (5) with Philips head screwdriver as per diagram.

Step 12

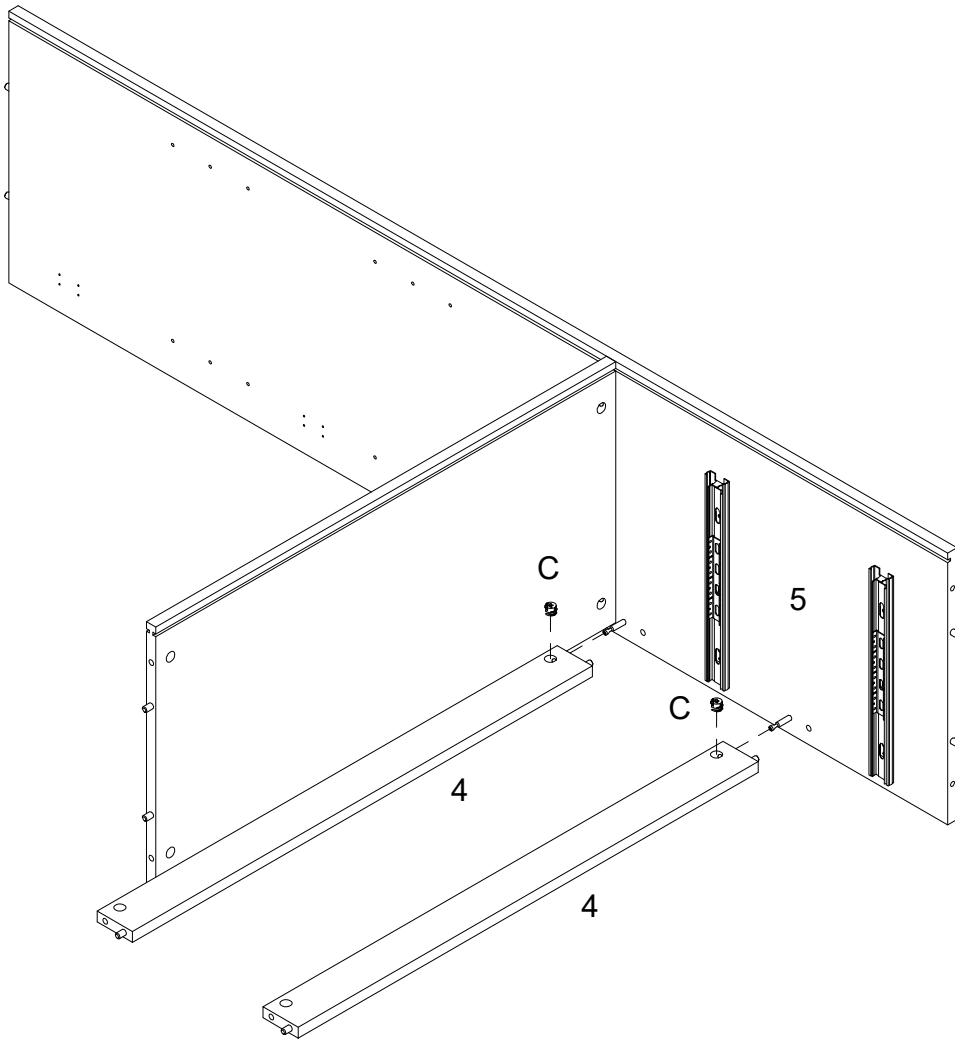
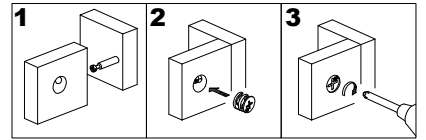

Using cam lock(C) secure part (4) to part (5) with Philips head screwdriver as per diagram.

Step 13

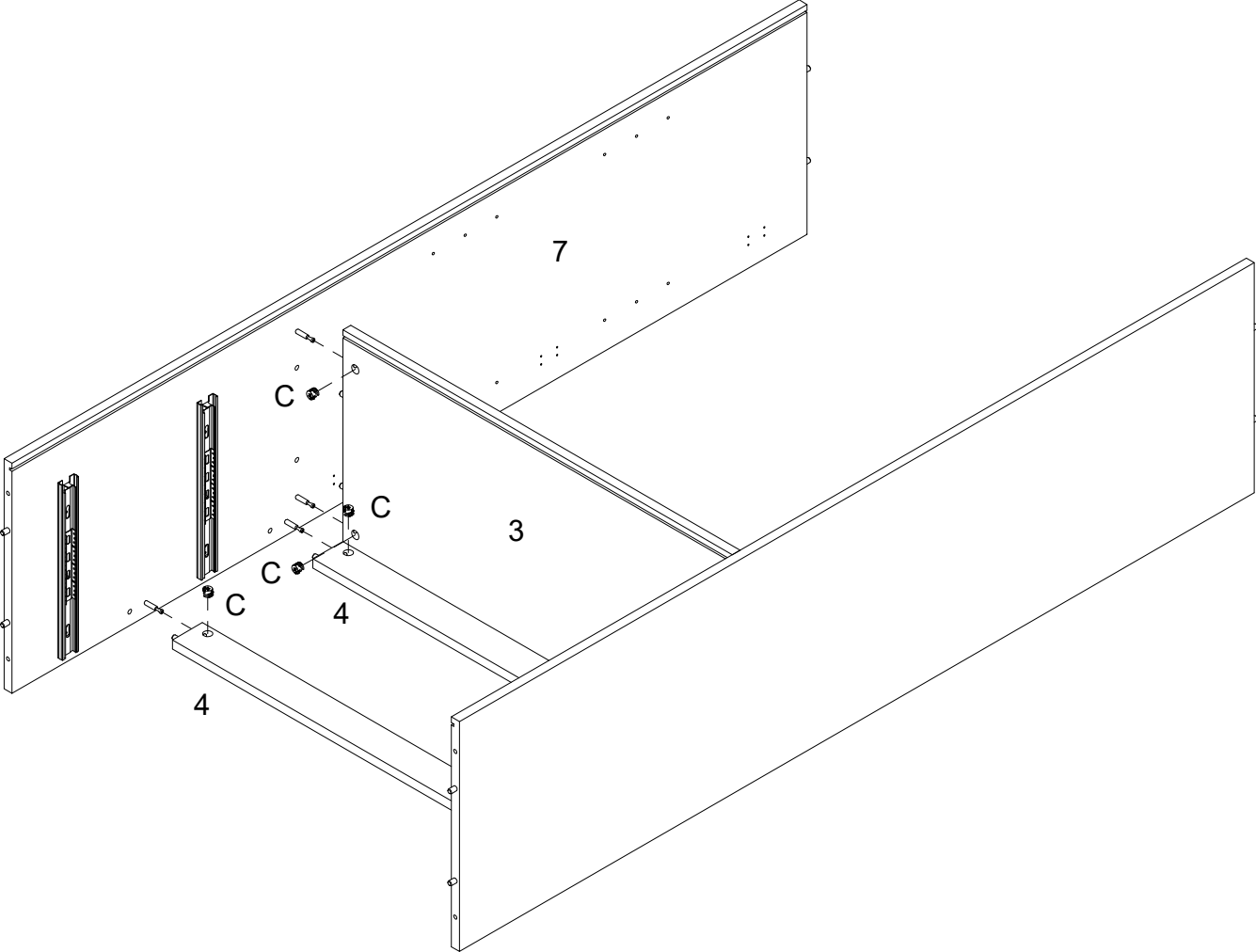
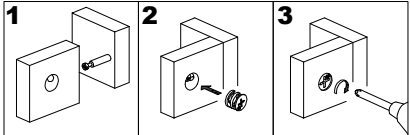

Using cam lock(C) secure part (7) to parts (3,4) with Philips head screwdriver as per diagram.

Step 14

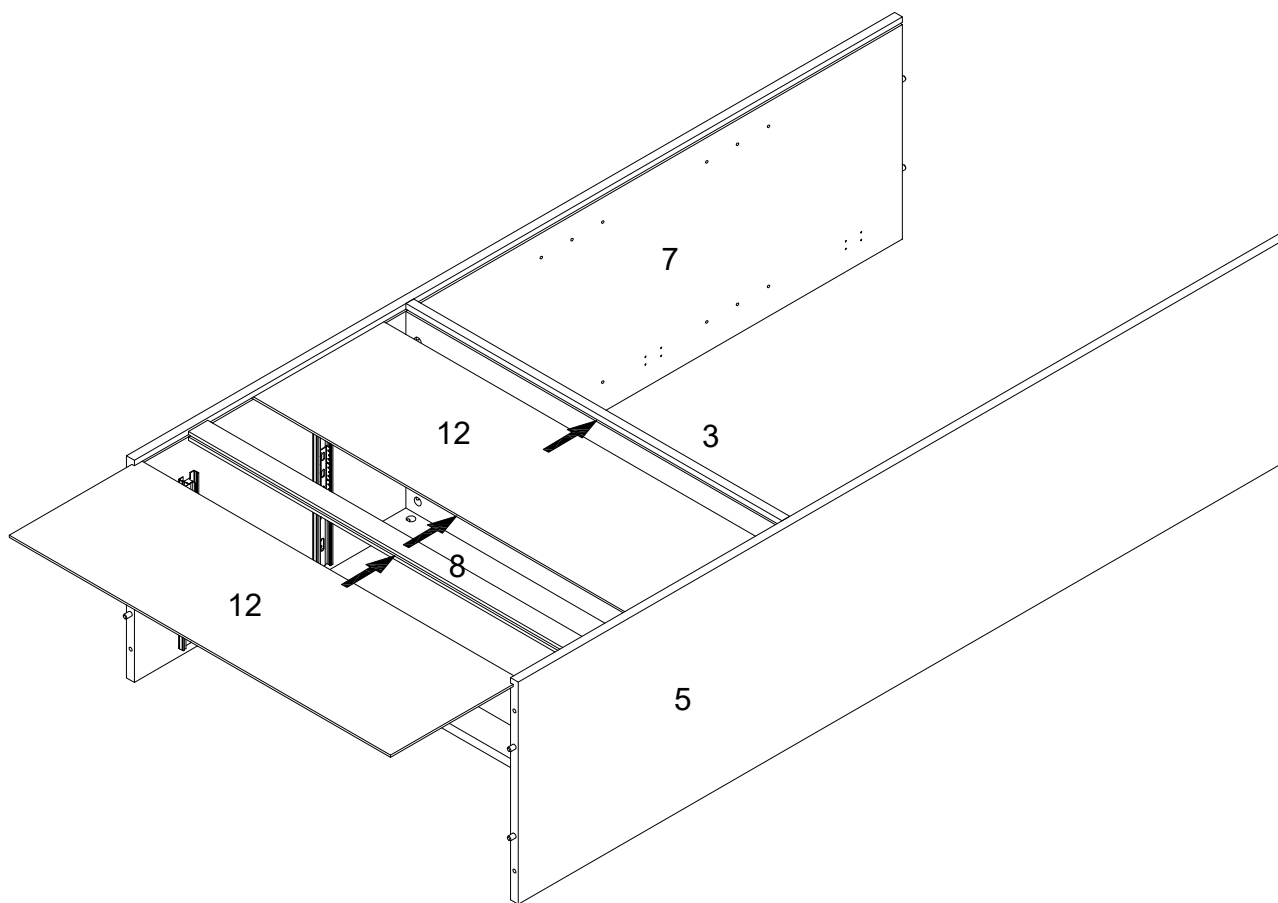

Put parts (8,12) as per diagram.

Step 15

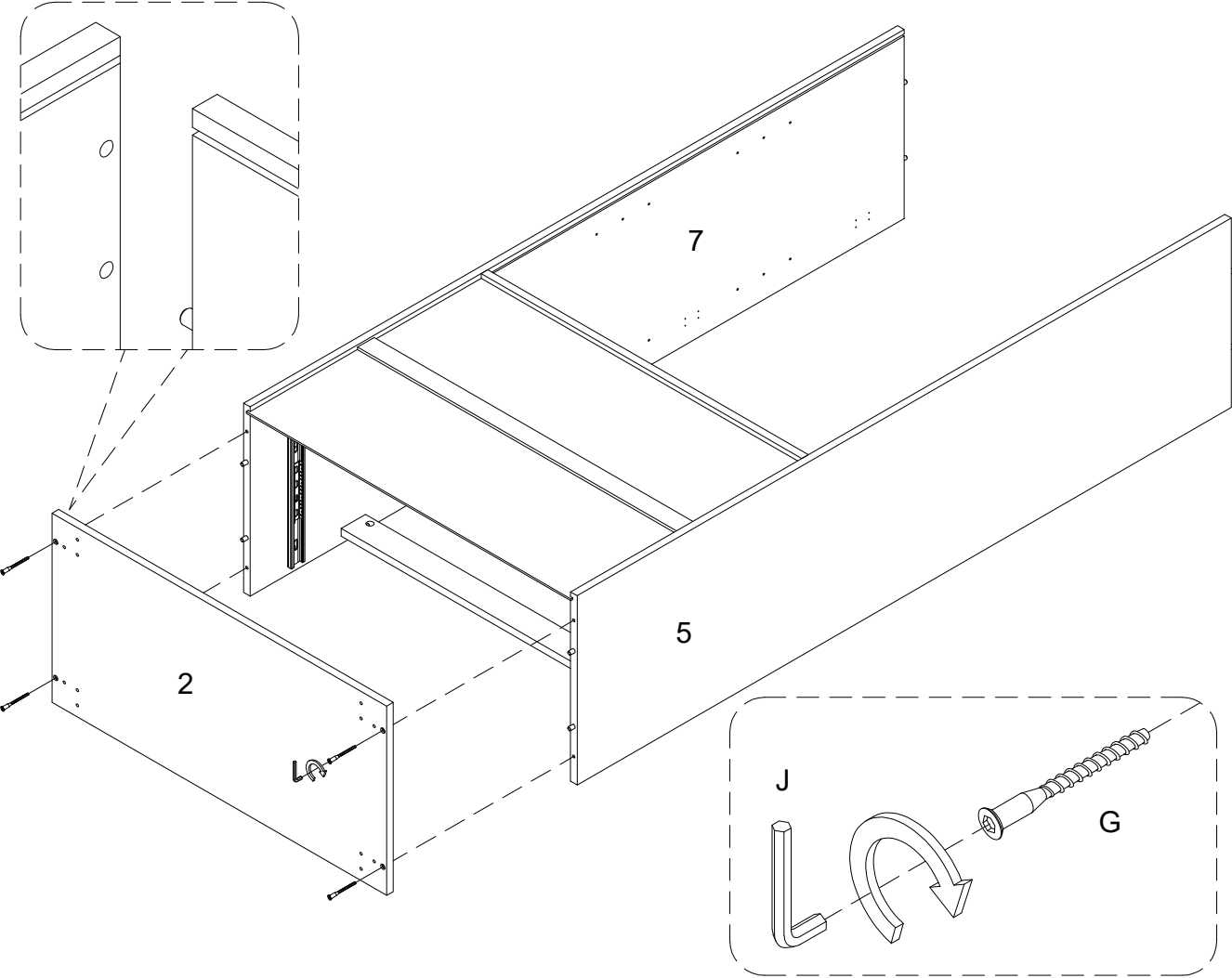

Using screw (G) attach part (2) into parts (5,7) with hex key (J) as per diagram.

Step 16

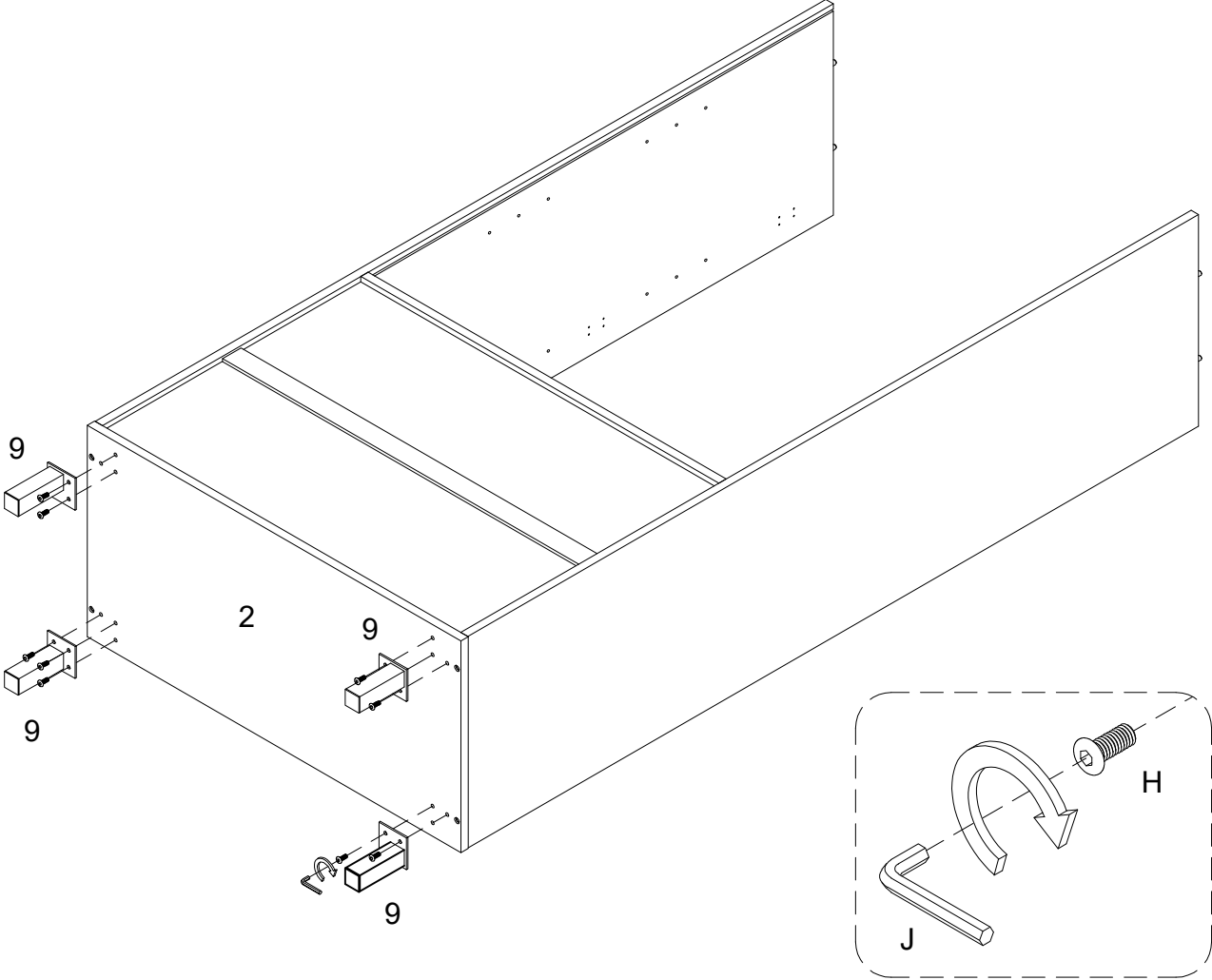

Using bolt (H) attach part (9) into part (2) with hex key (J) as per diagram.

Step 17

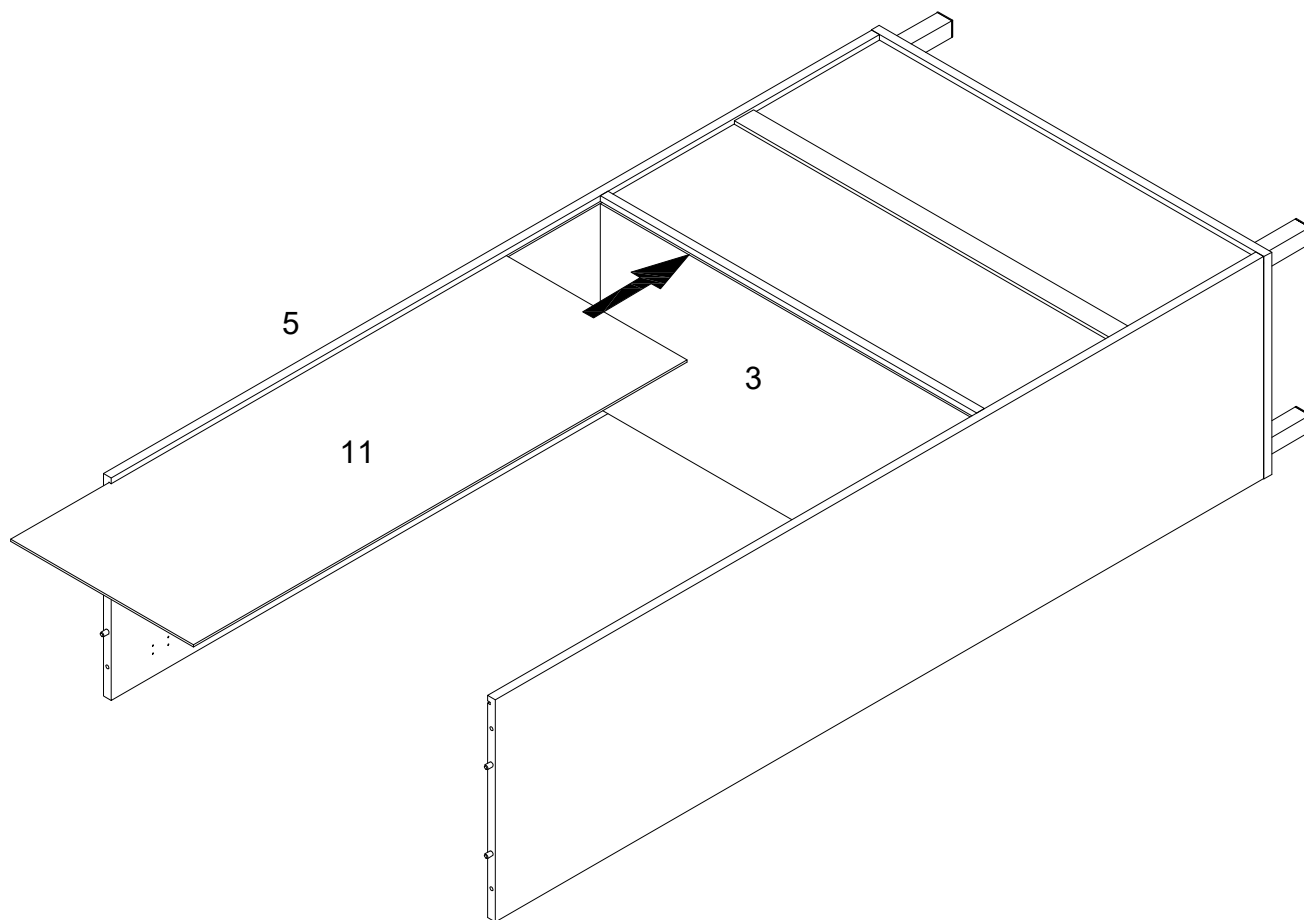

Put part (11) as per diagram.

Step 18

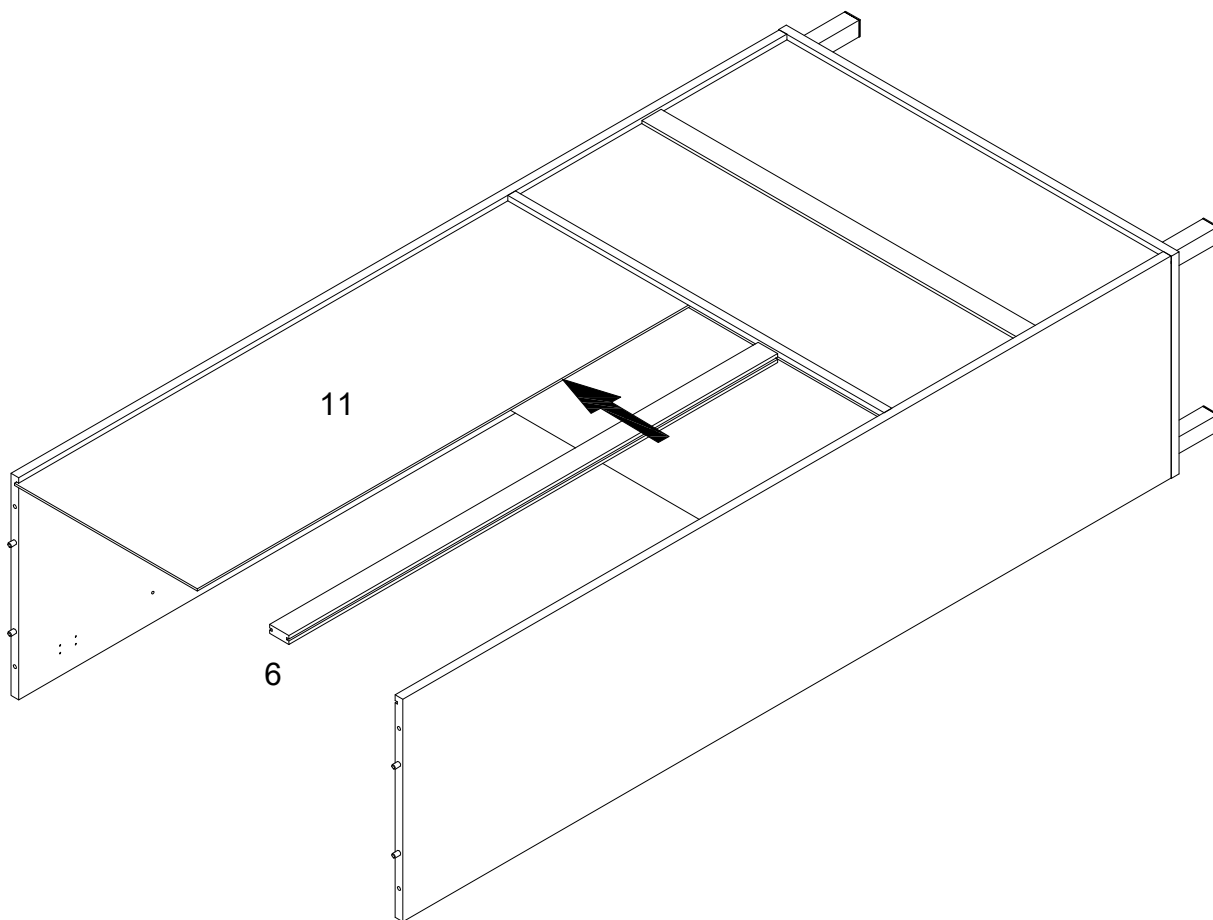

Put part (6) as per diagram.

Step 19

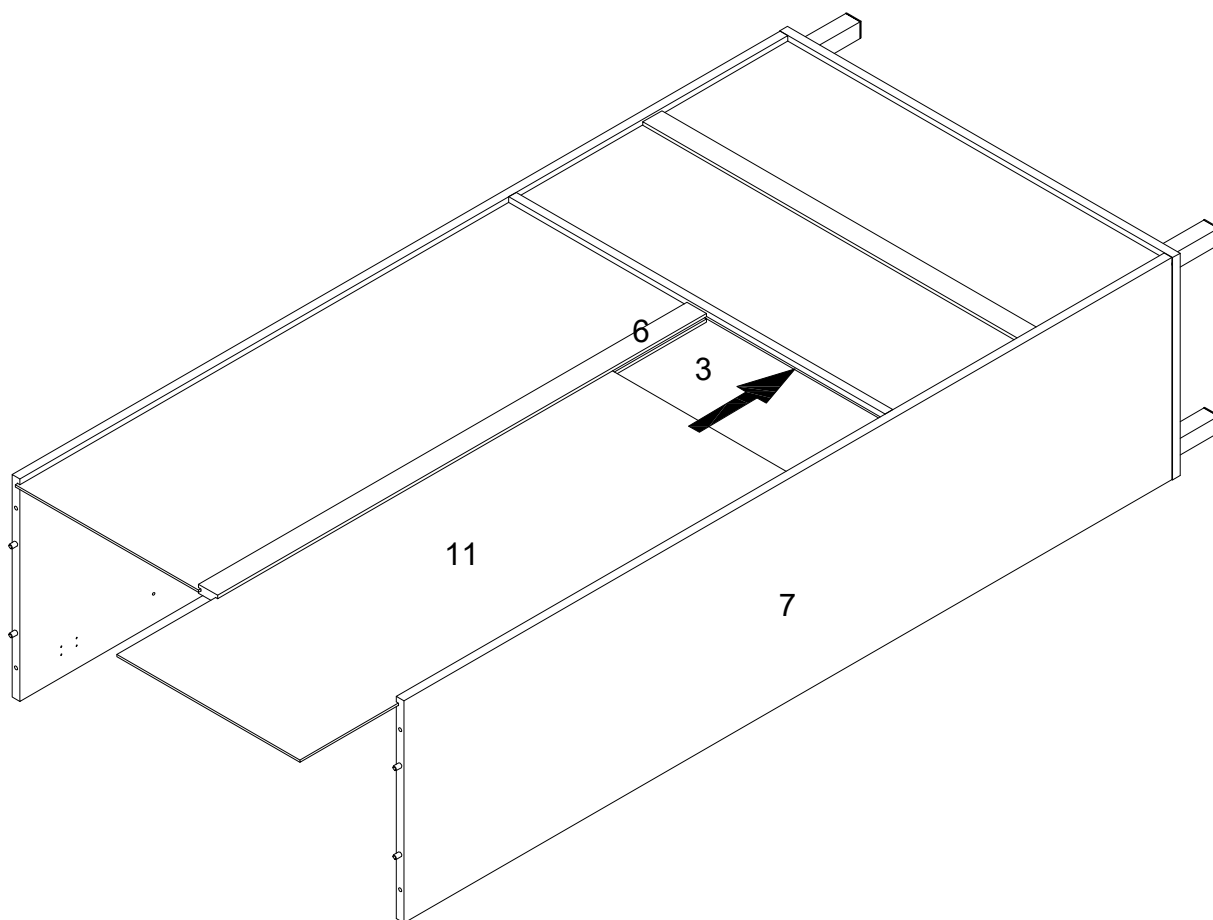

Put parts (11) as per diagram.

Step 20

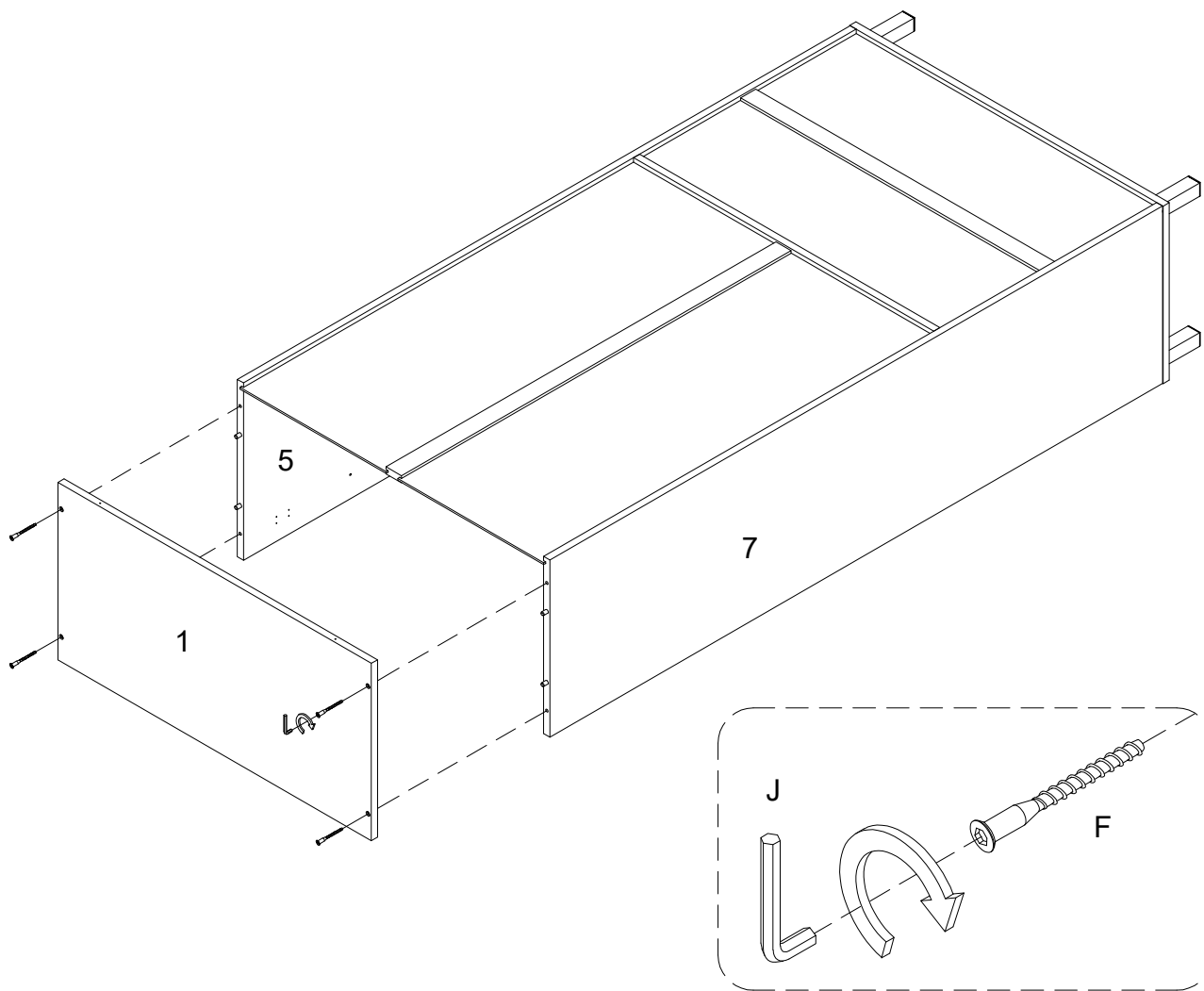

Using screw (F) attach part (1) into parts (5,7) with hex key (J) as per diagram.

Step 21

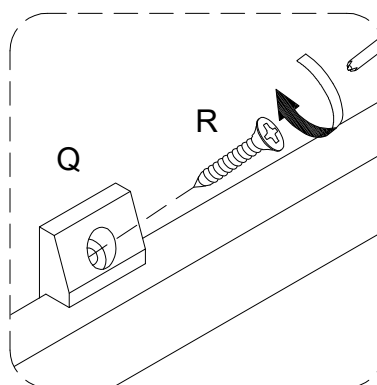
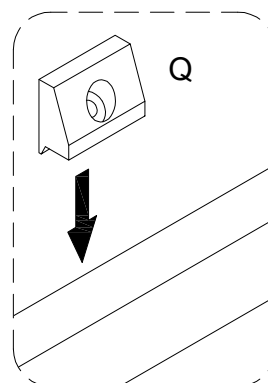
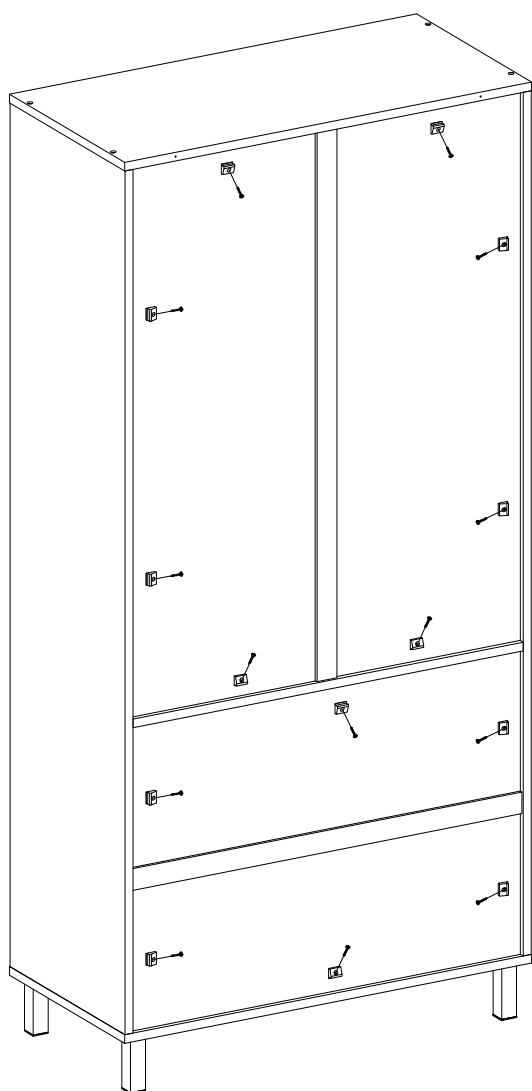

Using screw (R) secure plastic wedge (Q) with Philips head screwdriver as per diagram.

Step 22

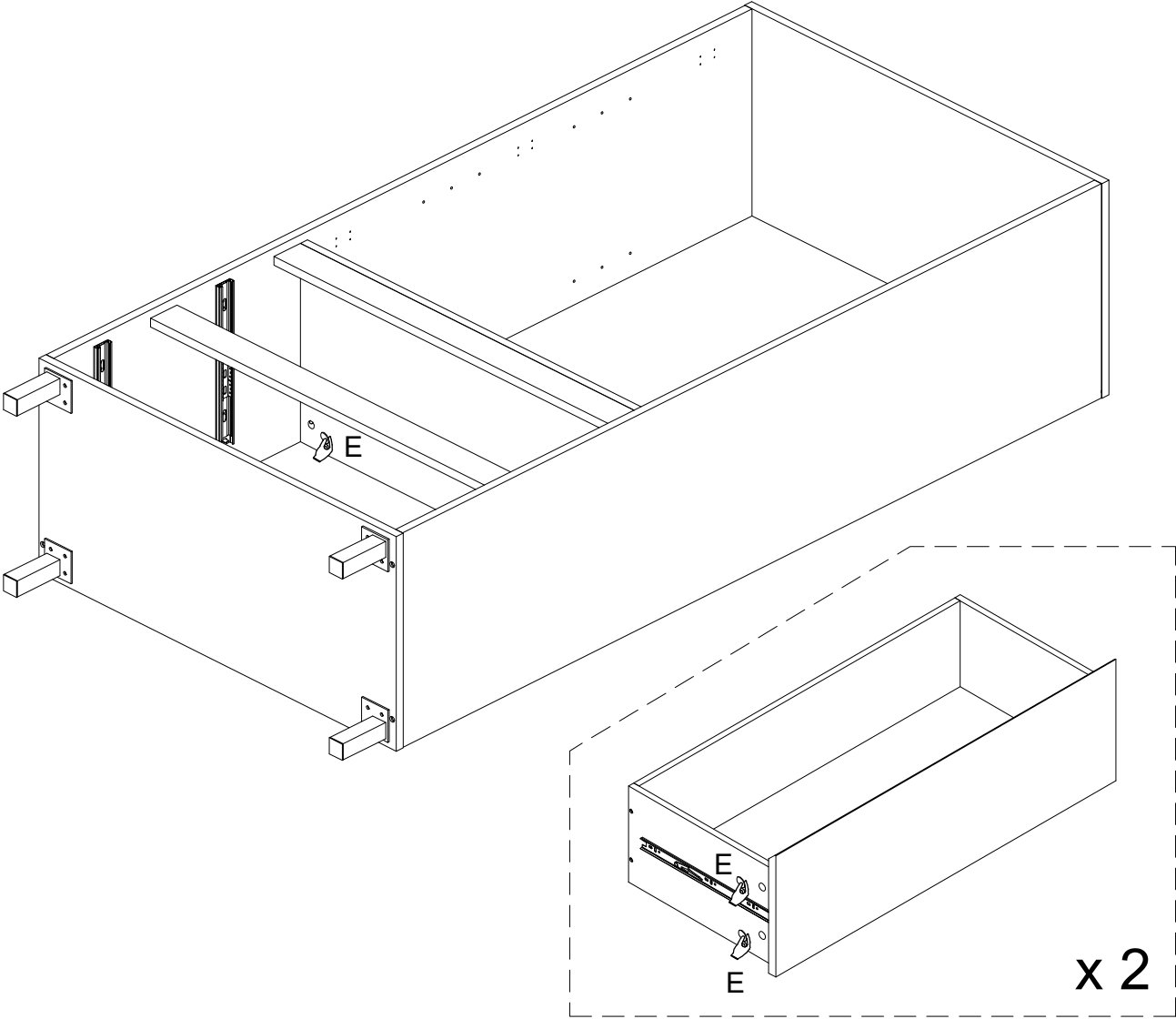

Place sticker (E) cover the holes as per diagram .

Step 23

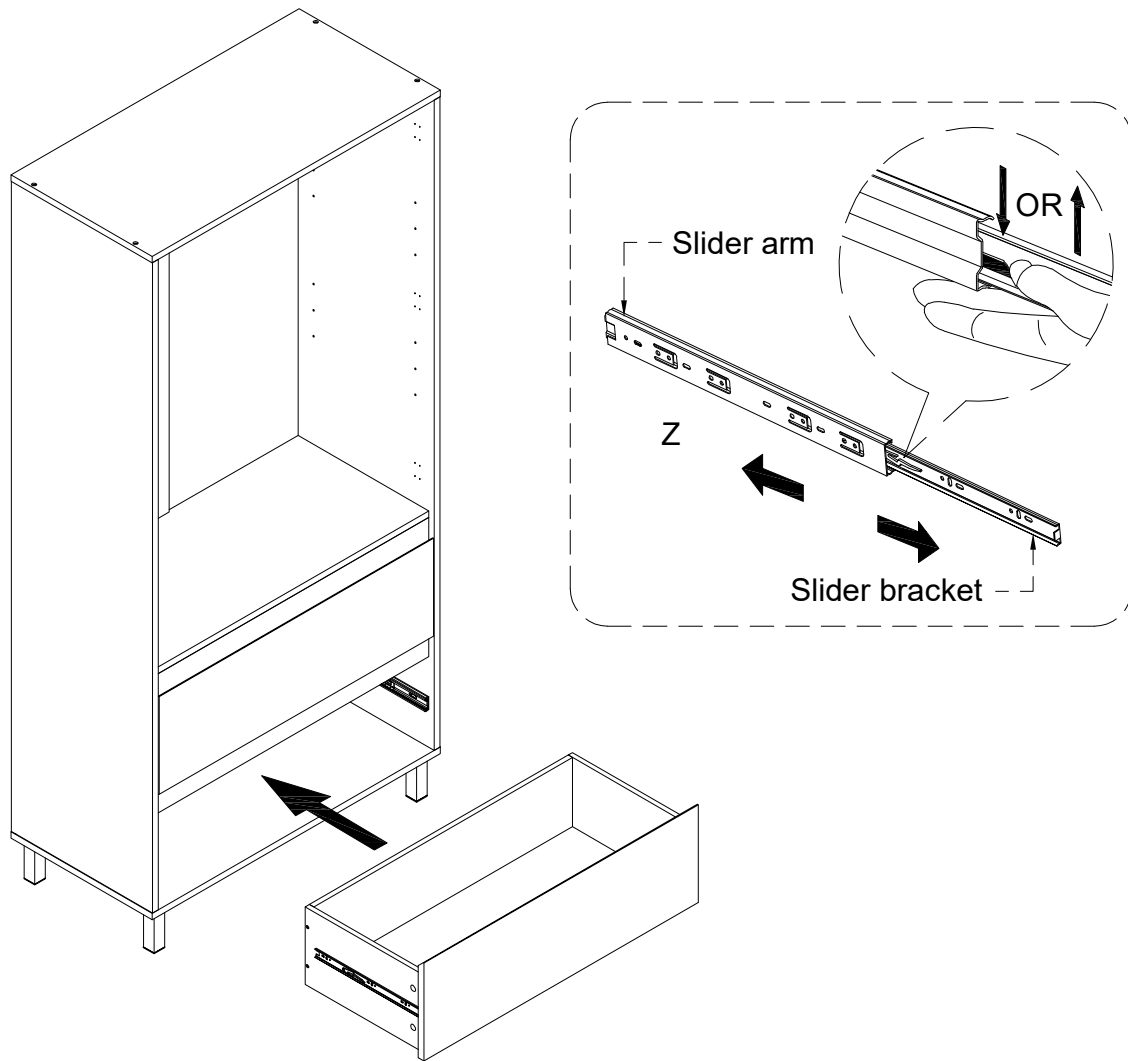

Assembled the drawers as per diagram

Note :If the drawer does not go in smoothly .Press or lift the plastic release lever .

Pull out the slider bracket from the slider arm then re-assembled the drawer until they were going in smoothly well .

Step 24

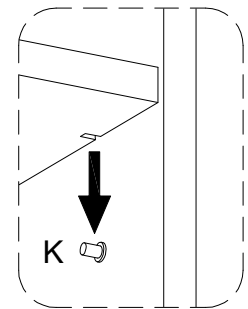
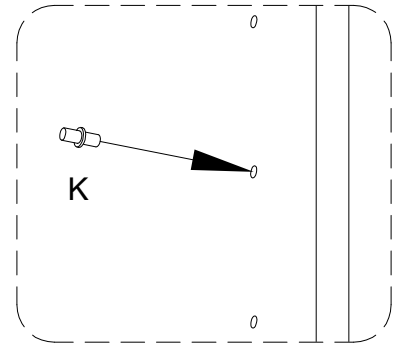
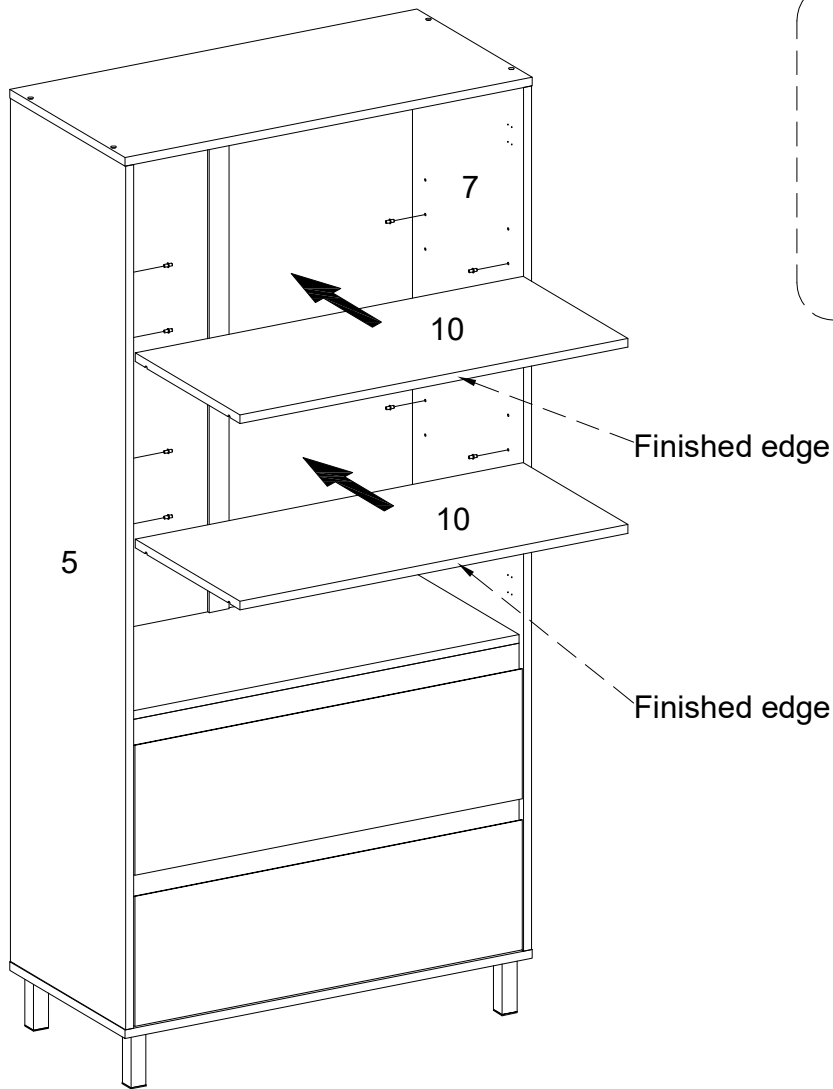

Insert shelf support pin (K) into parts (5,7) as per diagram. Make sure you place the four shelf support pins (K) in the same level. So the shelf is not titled .Put part(10) into unit as per diagram. Tilt and rest the adjustable shelf onto the shelf support pins .

Step 25

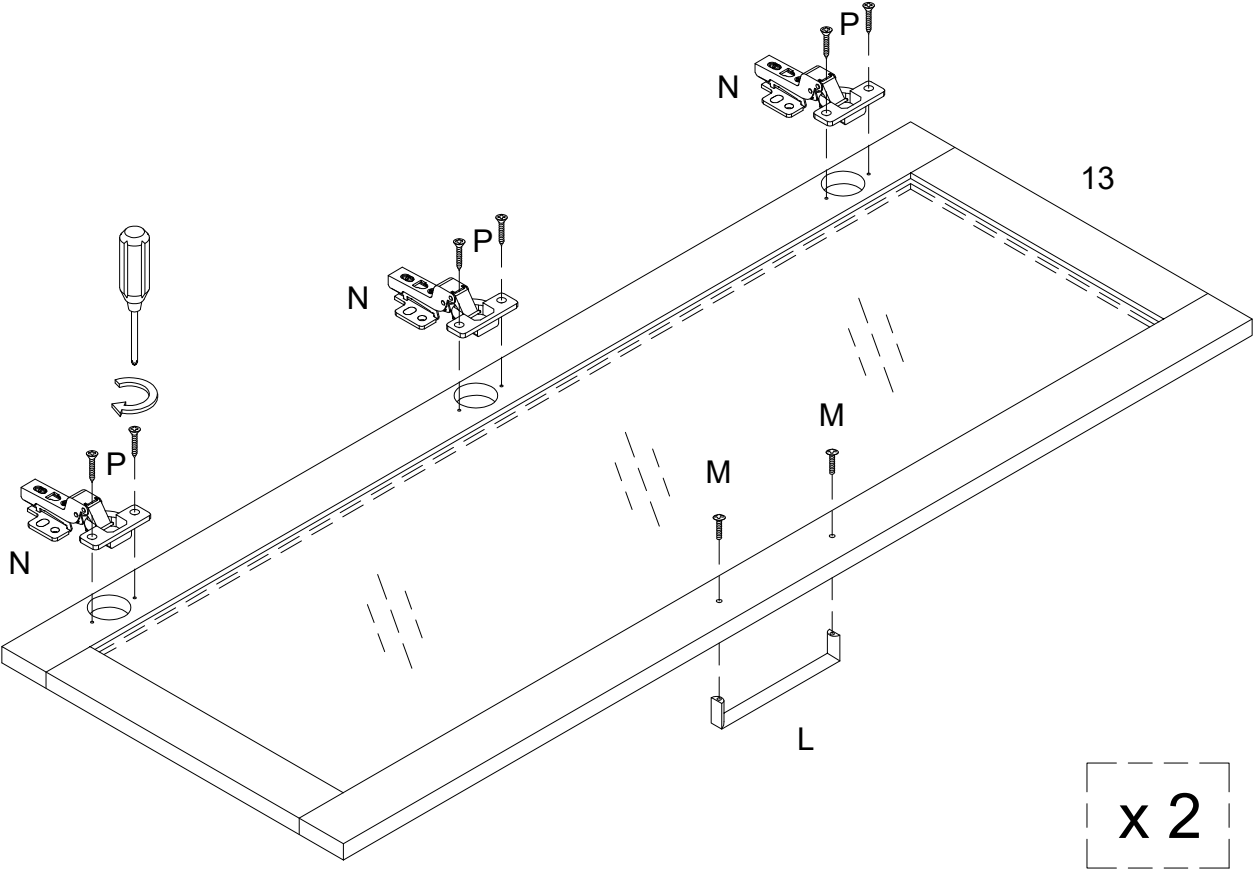

Using screw (P) attach Europe hinge (N) into part (13) ,then using screw (M) attach handle (L) to part (13) with Philips head screwdriver as per diagram.

Step 26

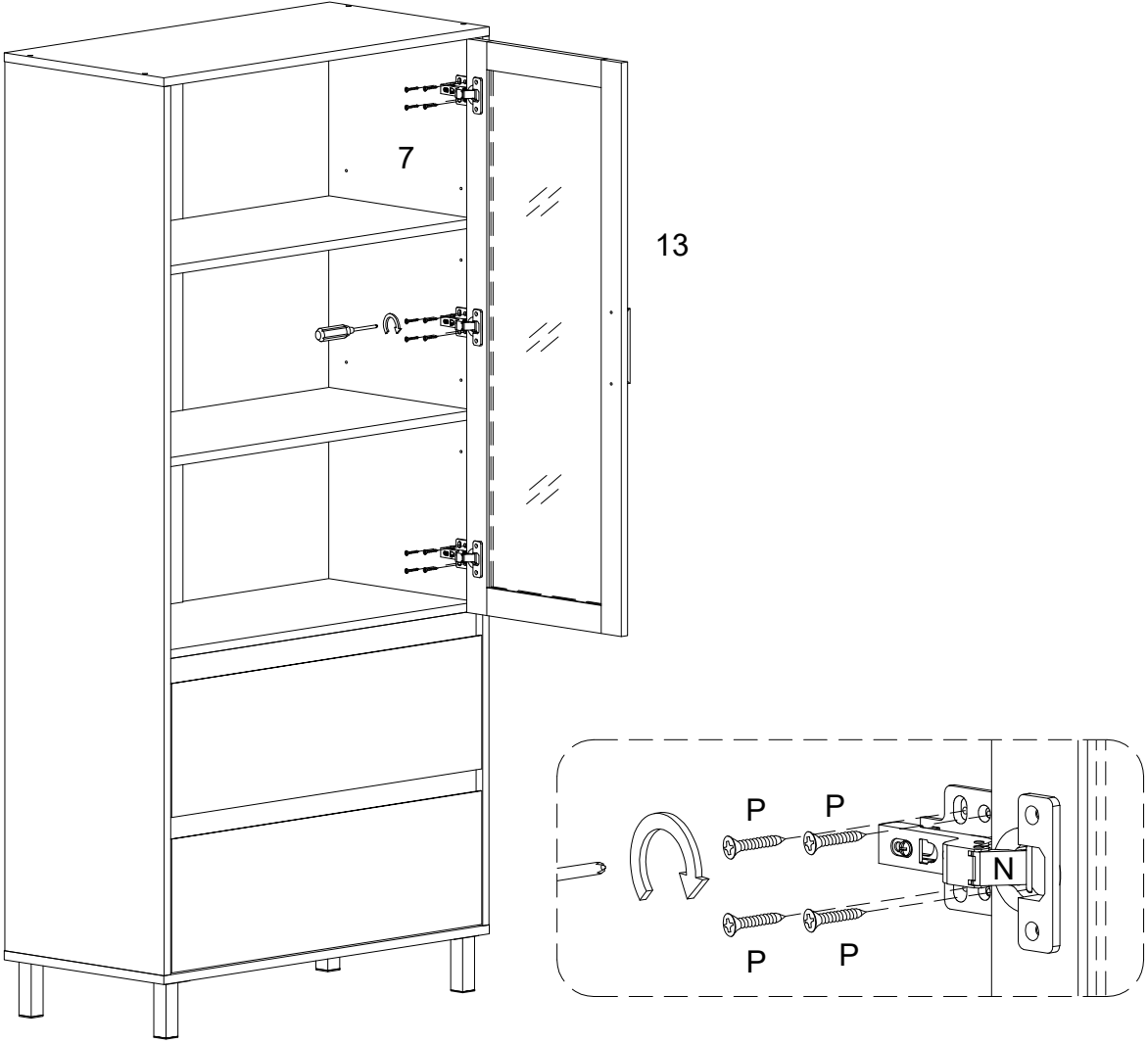

Using screw (P) attach Europe hinge (N) into part (7) with Philips head screwdriver as per diagram.

Step 27

13

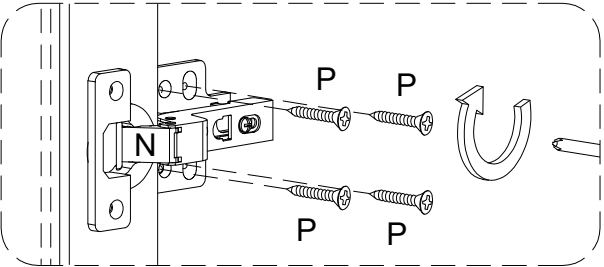
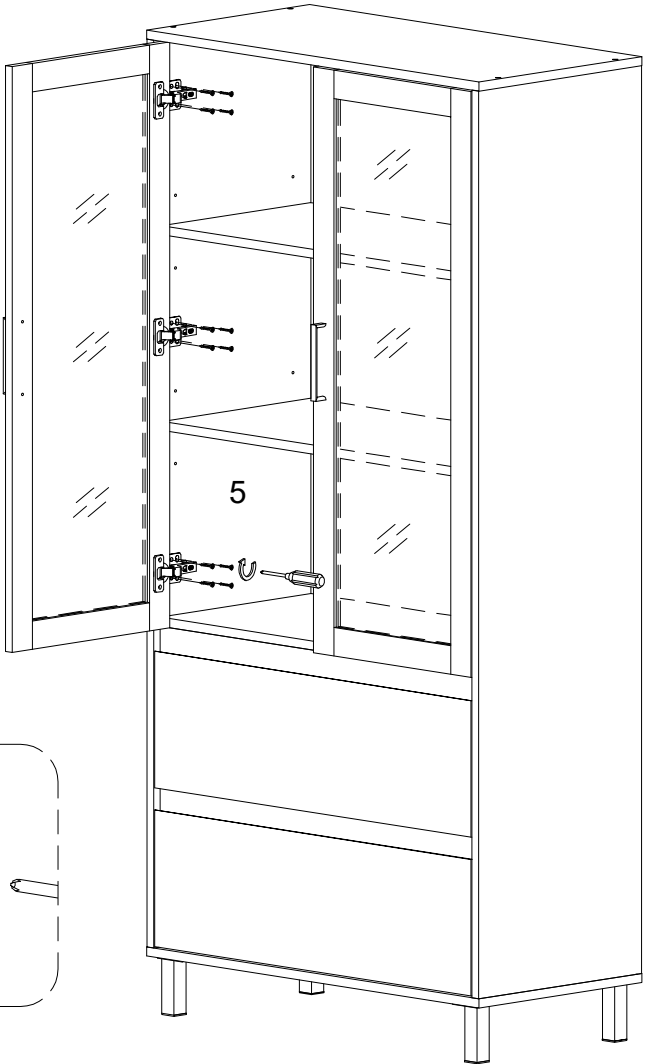

Using screw (P) attach Europe hinge (N) into part (5)with Philips head screwdriver as per diagram.

Step 28

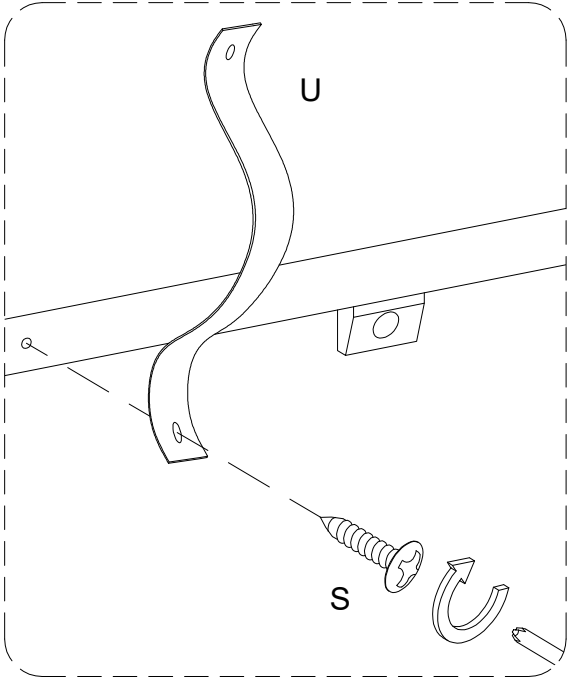
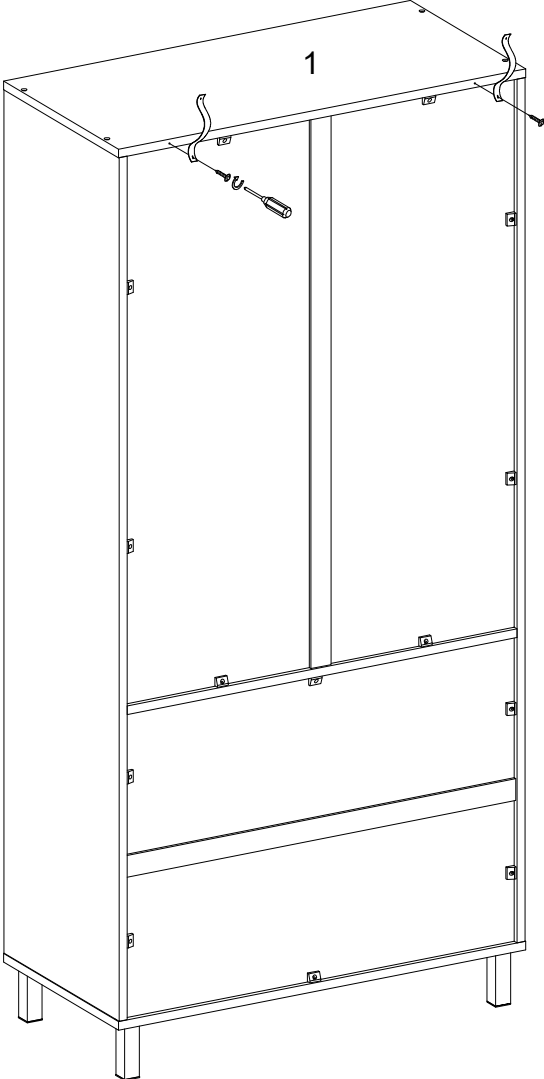

Using screw (S) attach Velcro strap (U) into part (1) with Philips head screwdriver as per diagram.

Step 29

WARNING

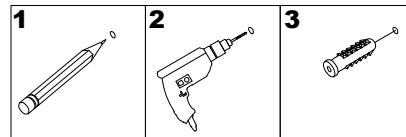

Serious or fatal injuries can occur from furniture tipping over. To prevent the furniture from tipping over we recommend that it is permanently fixed to the wall. Wall anchor and hardware are included with this product. Please make sure hardware is suitable for your walls before installing, as different wall materials may require different types of anchors.

Wall

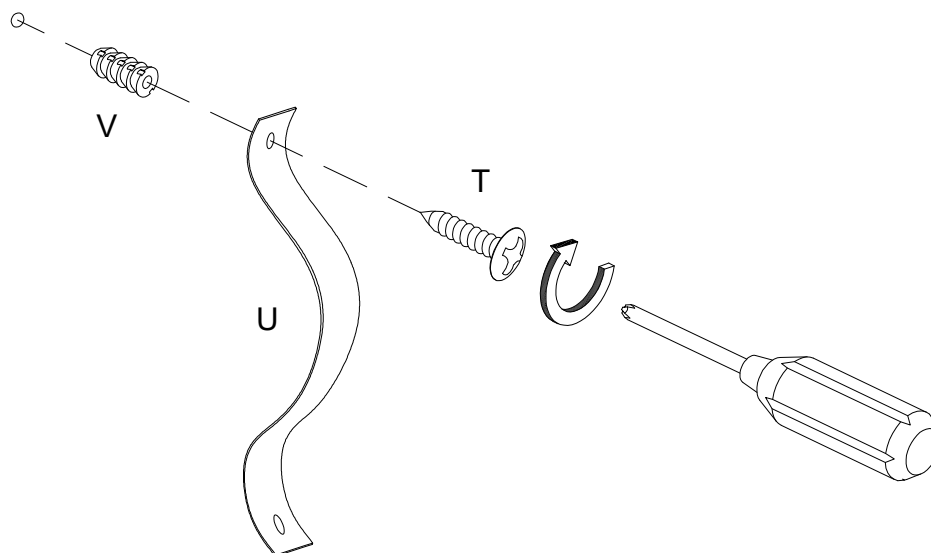

(EN)

Using screw (T) attach plastic strap (U) into nut (V) to wall with Philips head screwdriver as per diagram.

Step 30

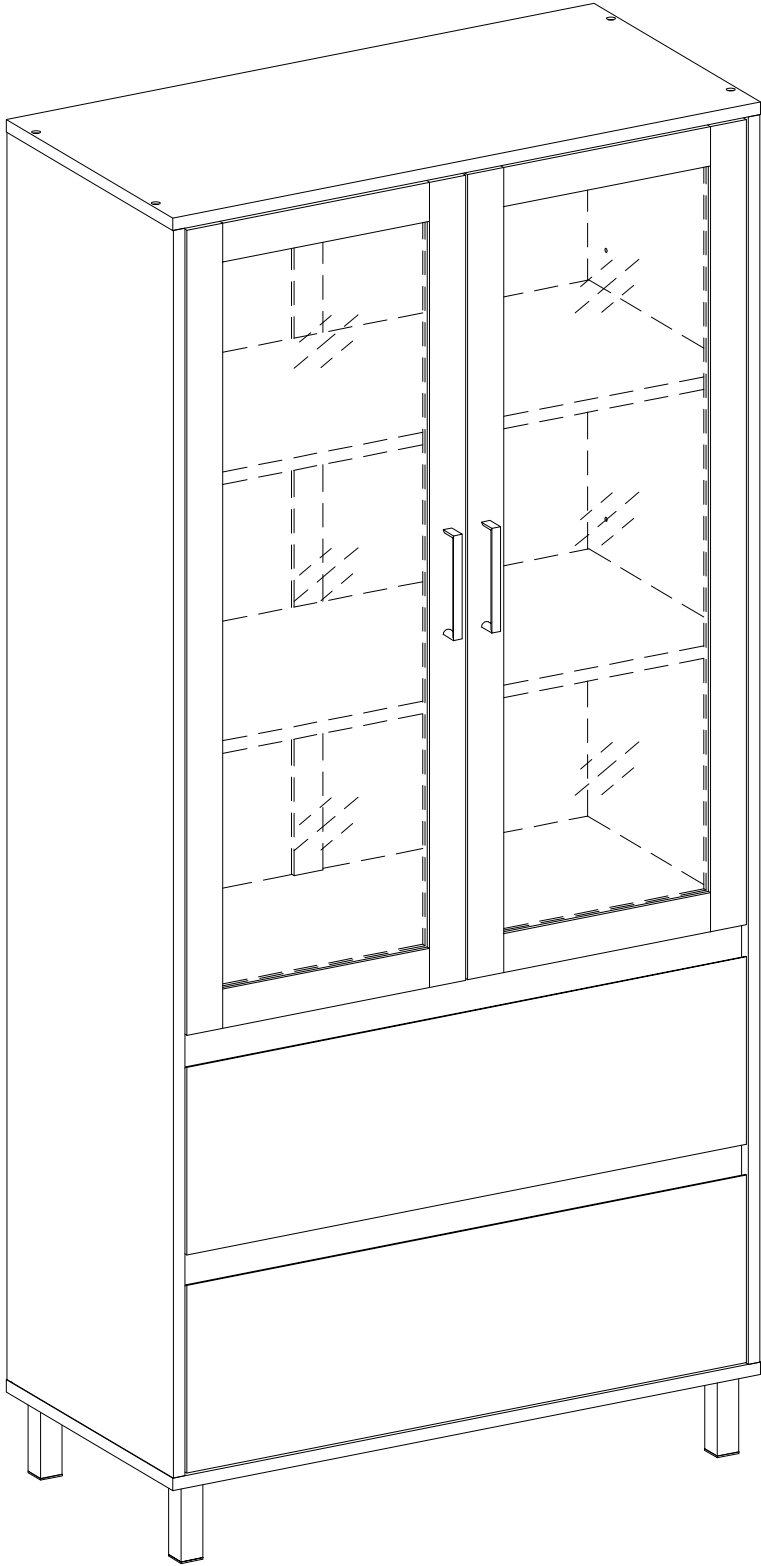

Final Assembly