

# Owner Manual

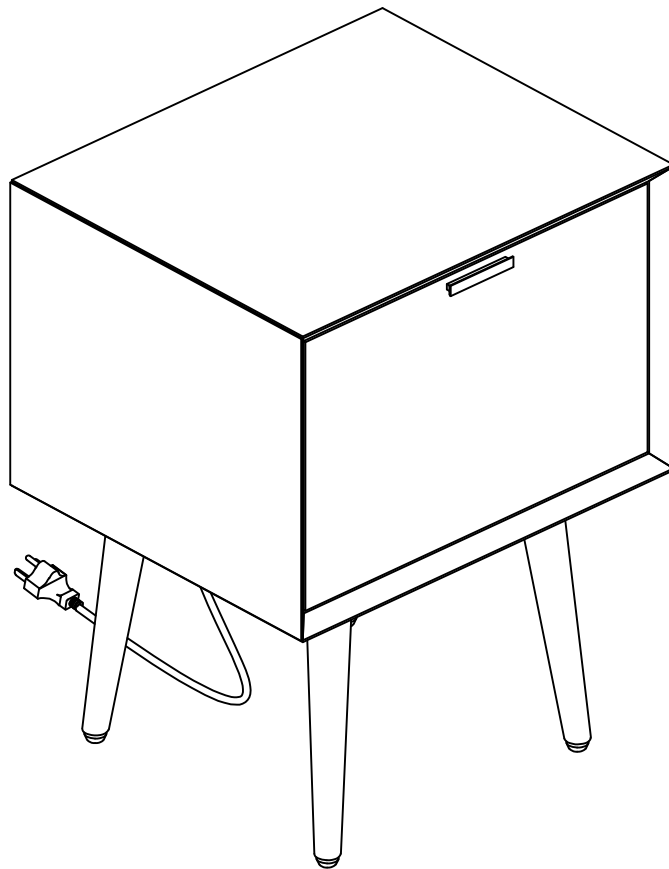

---

## NOTE:

This brochure contains IMPORTANT safety info. Please read and keep for future reference.

---

# MAINTAINANCE AND WARNING

- 1.Keep furniture away from heat sources.
- 2.Do not clean furniture with harsh cleaner or polishes.Do not use detergents,solvents,abrasives,spray packs or leather cleaner. Use non-color mild soa with warm water to clean spills(Mix 1:10 soap to water).
- 3.Do not place furniture under direct sunlight,material will possibly fade over time.
- 4.Do not use on site dry cleaning machine.Children should not climb or jump on the furniture.
- 5.Do not write on furniture that is not protectedby a padded barrier.
- 6.Not for commercial use,only for residential use.



# EXPLOSIVE VIEW

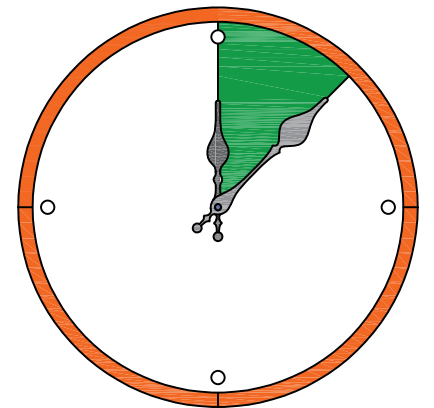
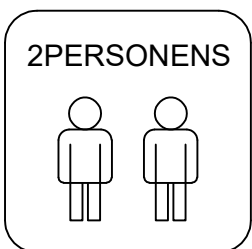
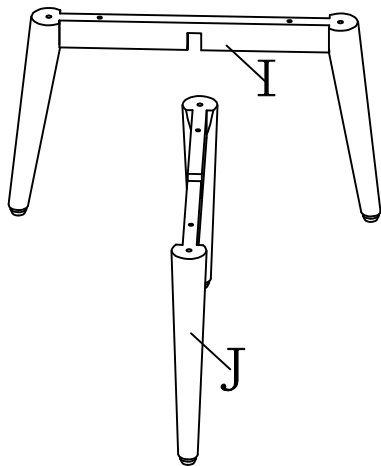
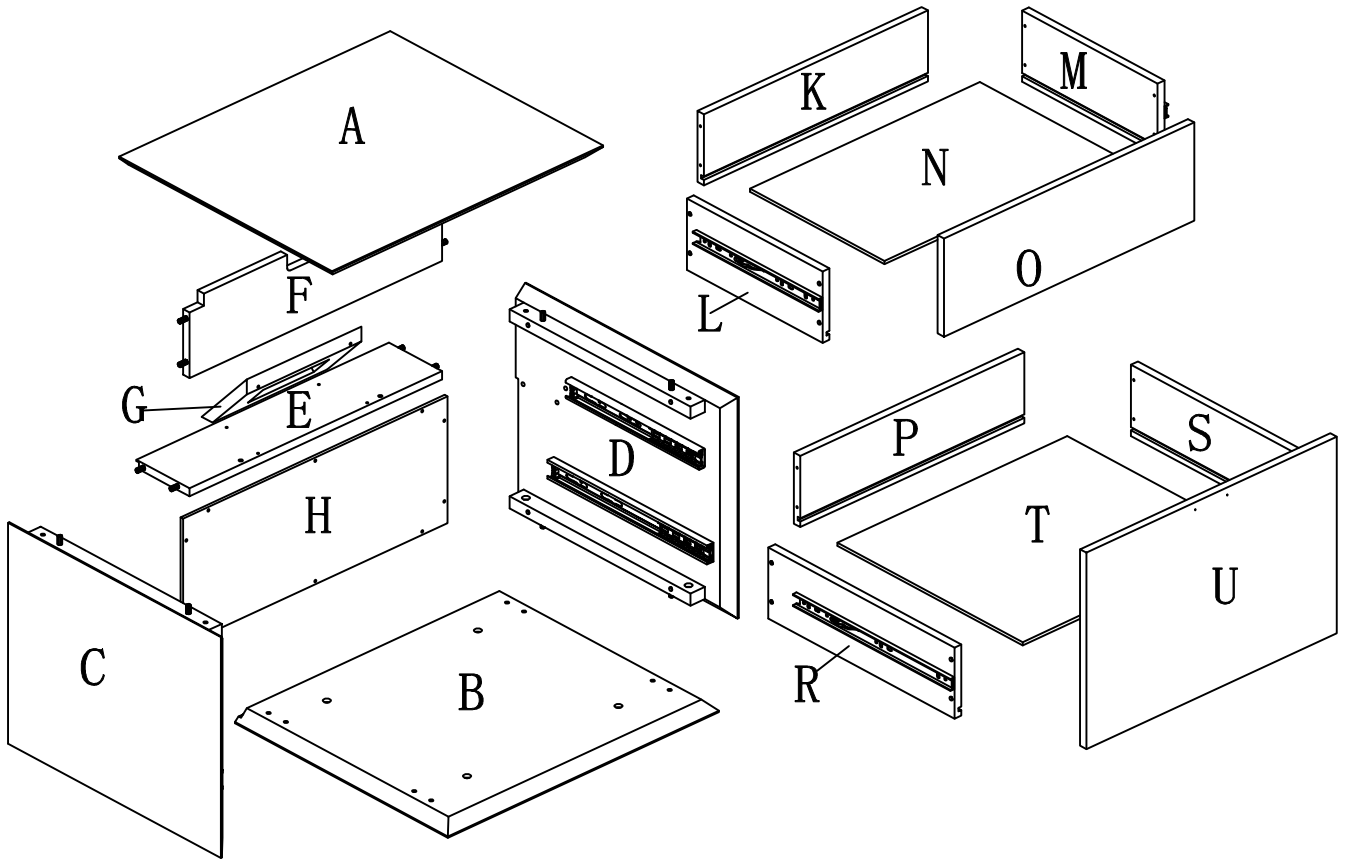

Around 40 min



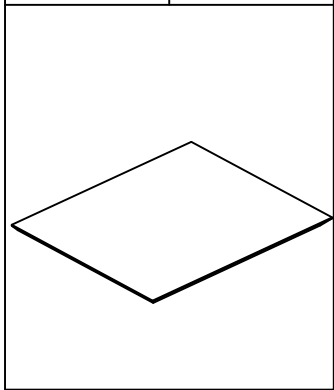
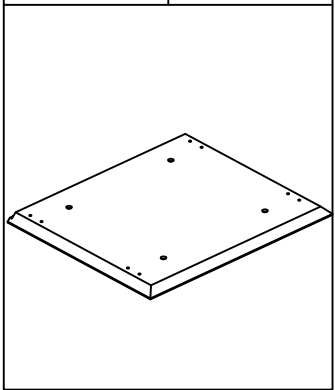
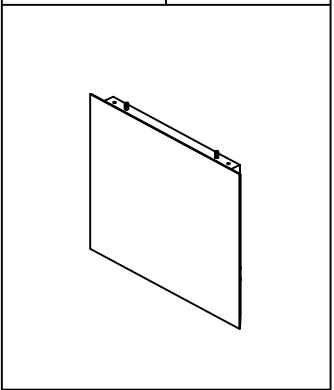
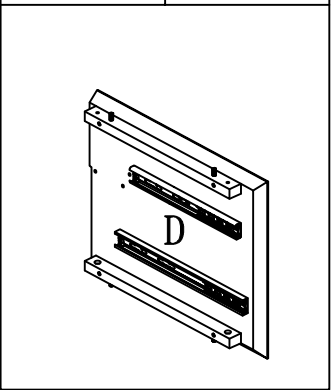
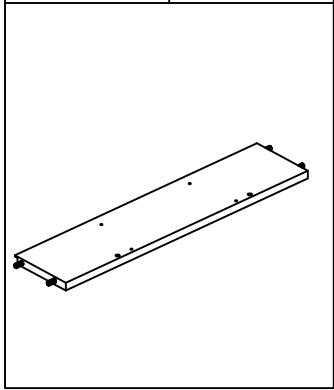
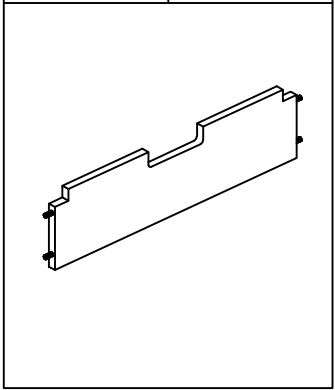
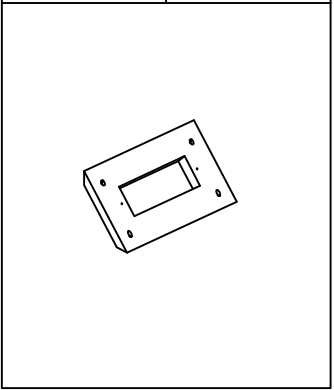
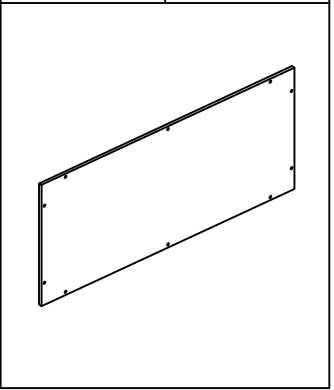
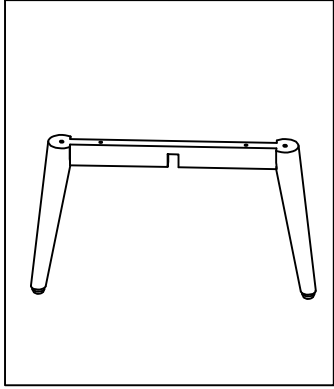
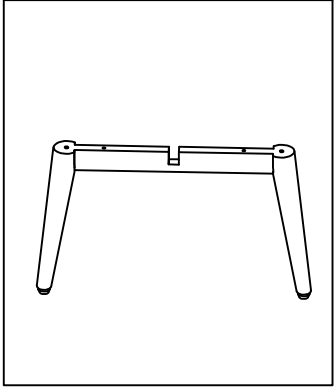
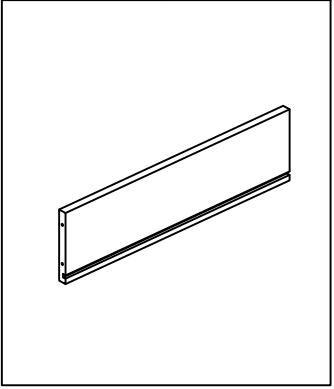
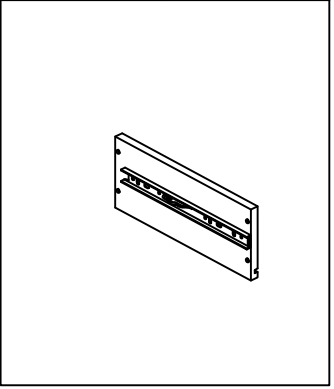
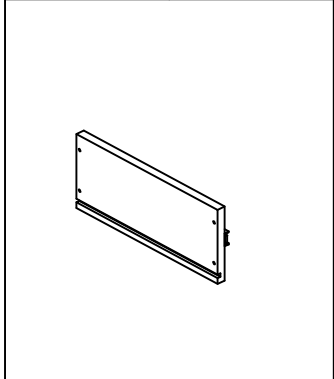
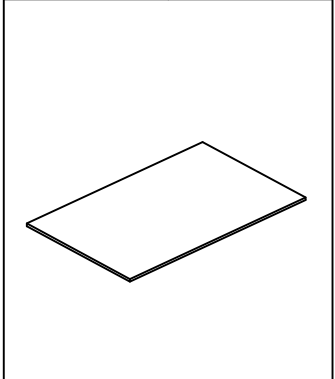
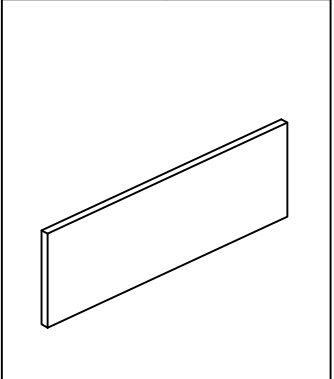
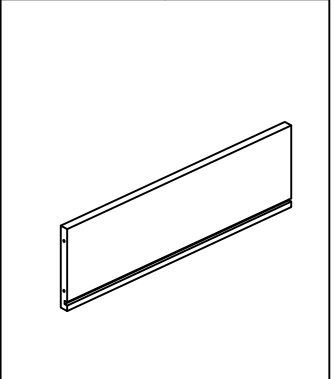



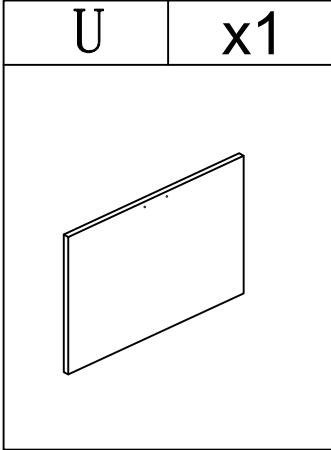
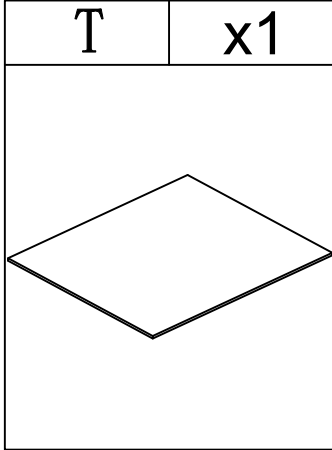
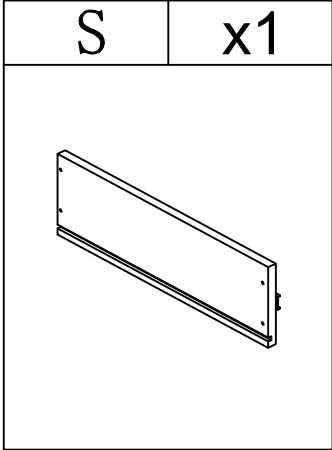
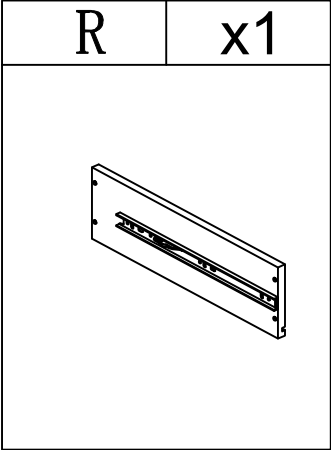

# PARTS LIST 1

A	x1	B	x1	C	x1	D	x1
							
E	x1	F	x1	G	x1	H	x1
							
I	x1	J	x1	K	x1	L	x1
							
M	x1	N	x1	O	x1	P	x1
							

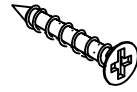
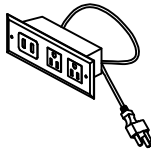
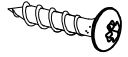
# PARTS LIST 2



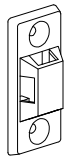
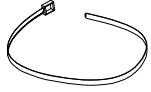
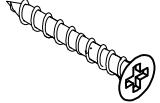

# HARDWARE LIST

#1	x2	#2	x2	#3	x1	#4	x22	#5	x1	#6	x10
											
Ø4*15MM		Ø3*12MM				Ø4*25MM				Ø3*15MM	
#7	x4	#8	x12	#9	x2	#10	x2	#11	x1	#12	x2
											
Ø6*45MM		Ø6*22MM								Ø4*39MM	
#15	x2										
											
Ø3*20MM											

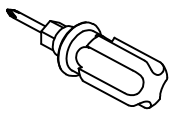
# TOOL LIST

#13	x1	#14	x1
			
M6			

# HARDWARE SPARE LIST

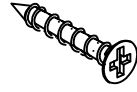
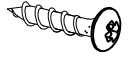
#7	x1	#8	x1	#4	x2	#6	x1
							
Ø6*45MM		Ø6*22MM		Ø4*25MM		Ø3*15MM	

# ASSEMBLY INSTRUCTIONS

## STEP-1

1. Combine part (I) and part (J), making sure their grooves face each other.
2. Attach the assembled parts (J&I) to the bottom panel B with bolt #7, ensure the corresponding holes are aligned. Tighten bolt with allen wrench #13.

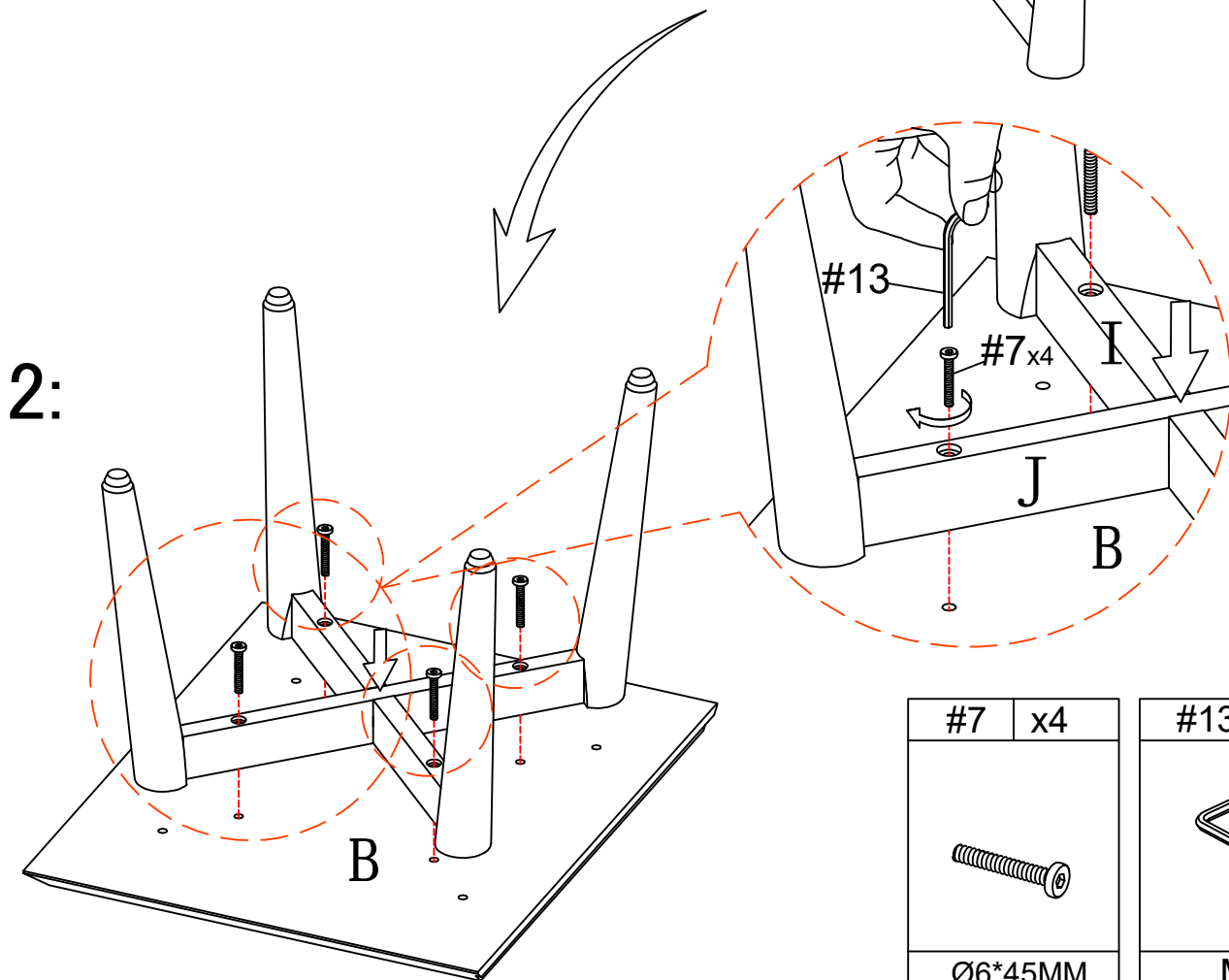
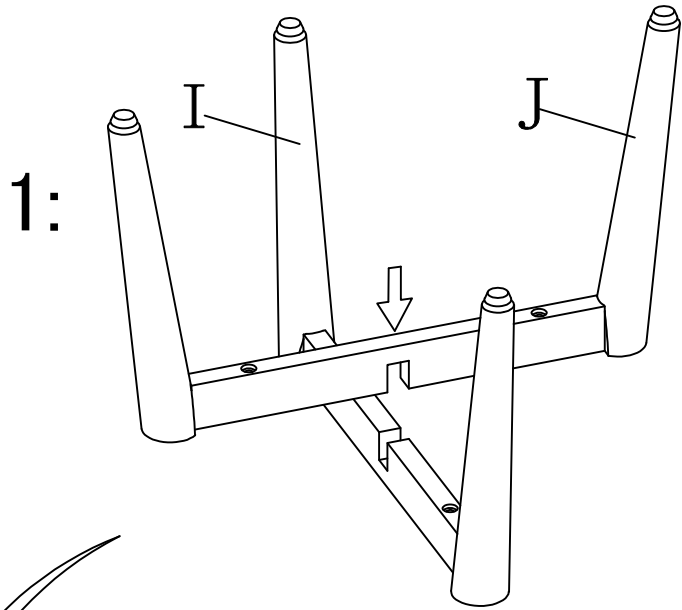

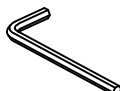
#7	x4	#13	x1
			
Ø6*45MM		M6	

# ASSEMBLY INSTRUCTIONS

## STEP-2

1. Insert part (F) into part (E), make sure all holes aligned and use screw #4 to attach them, tighten screw #4 with screwdriver #14.
2. Insert side panel (C&D) into panel (E&F), make sure all holes aligned as picture show.

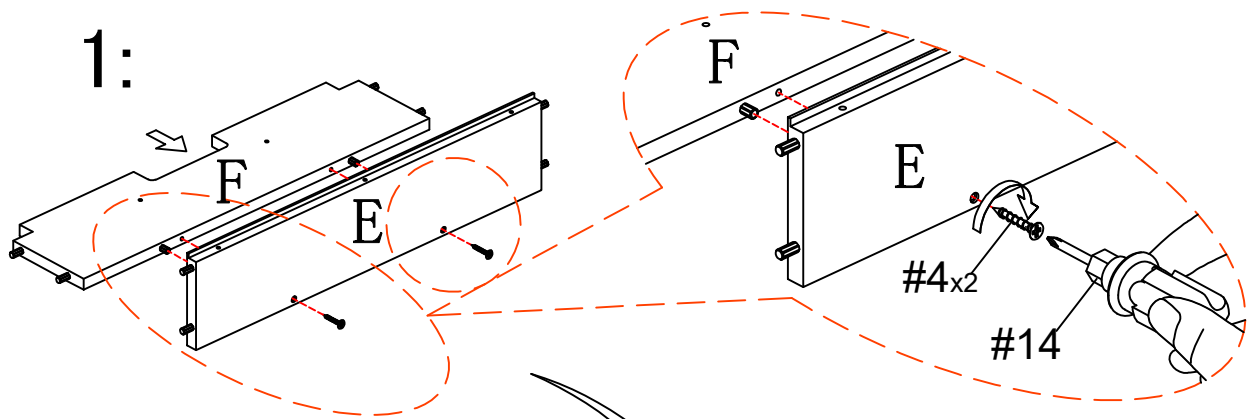

2:

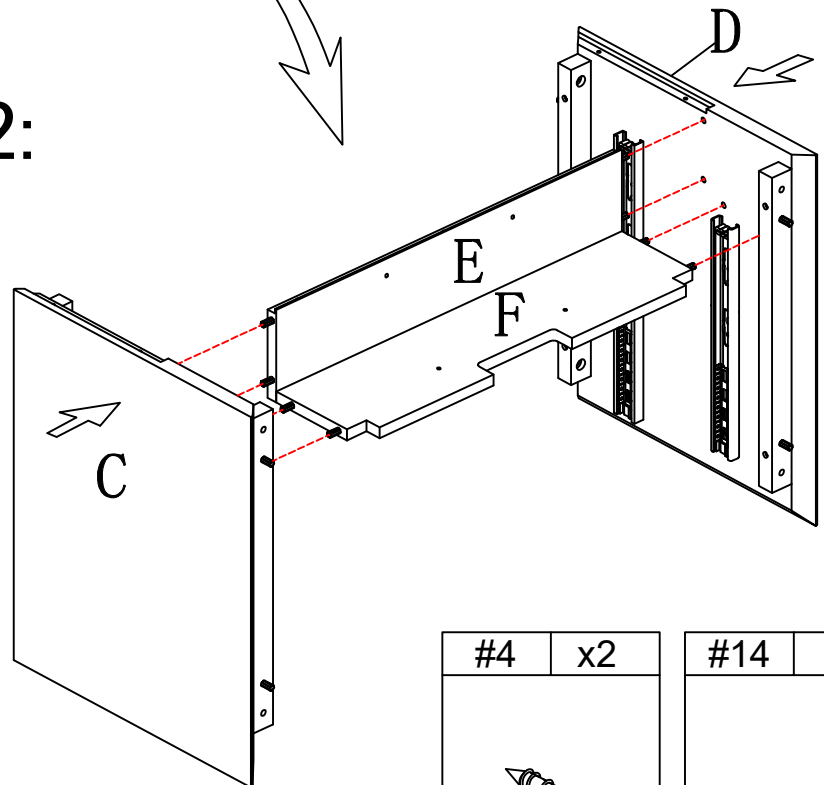

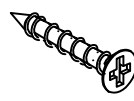
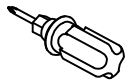

#4	x2	#14	x1
			
Ø4*25MM			

# ASSEMBLY INSTRUCTIONS

## STEP-3

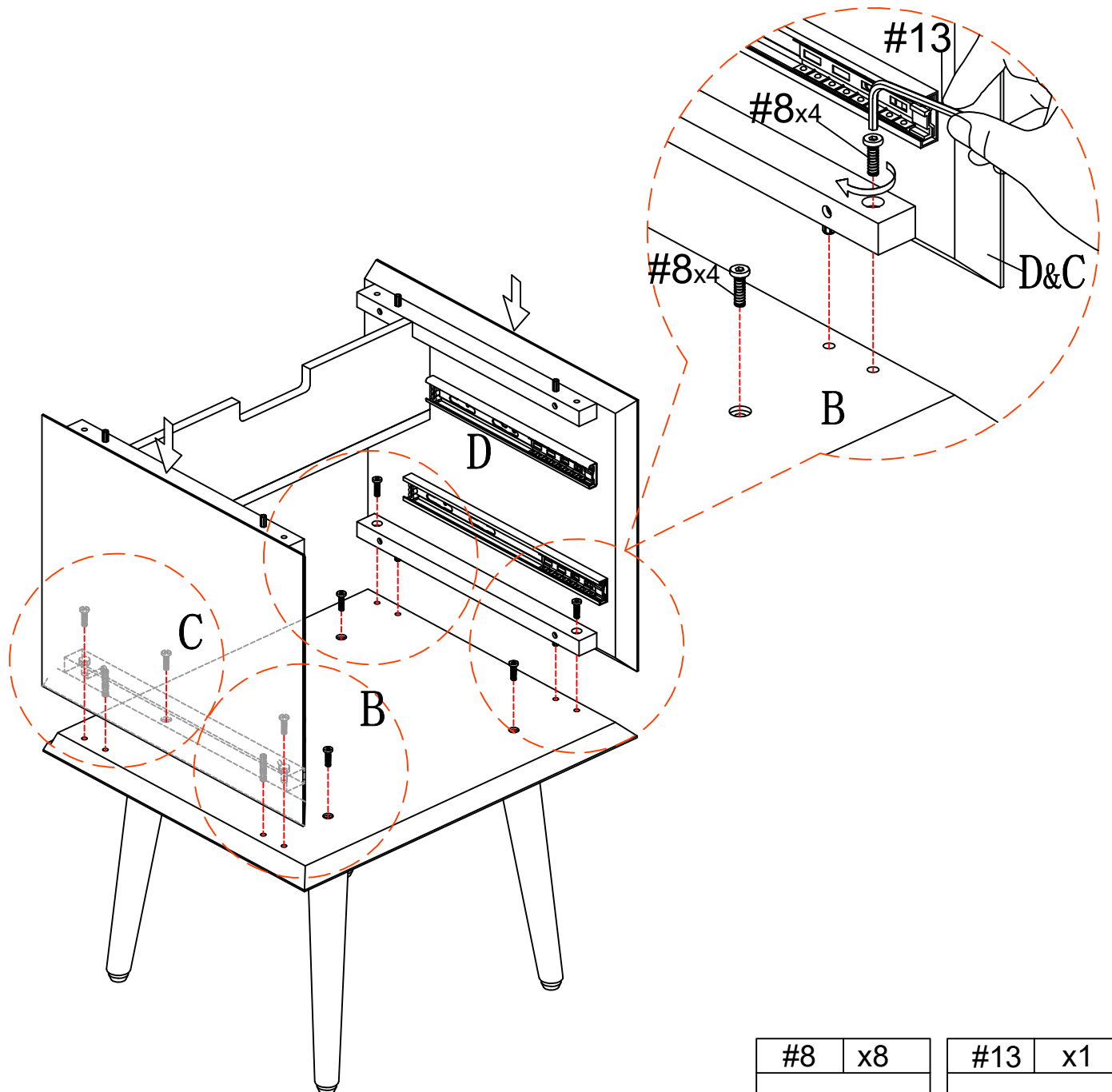
1. Insert pre-assembled unit on step 2 into the corresponding hole of bottom panel (B), make sure all holes aligned and use Bolt#8 to attach them, tighten bolt#8 with Allen Key #13.



#8	x8	#13	x1
			
Ø6*22MM		M6	

# ASSEMBLY INSTRUCTIONS

## STEP-4

1.insert back panel(H) into the groove of pre-assembled unit on step 3,make sure all holes aligned and use screw#6 to attach them , tighten screw #6 with screwdriver#14.

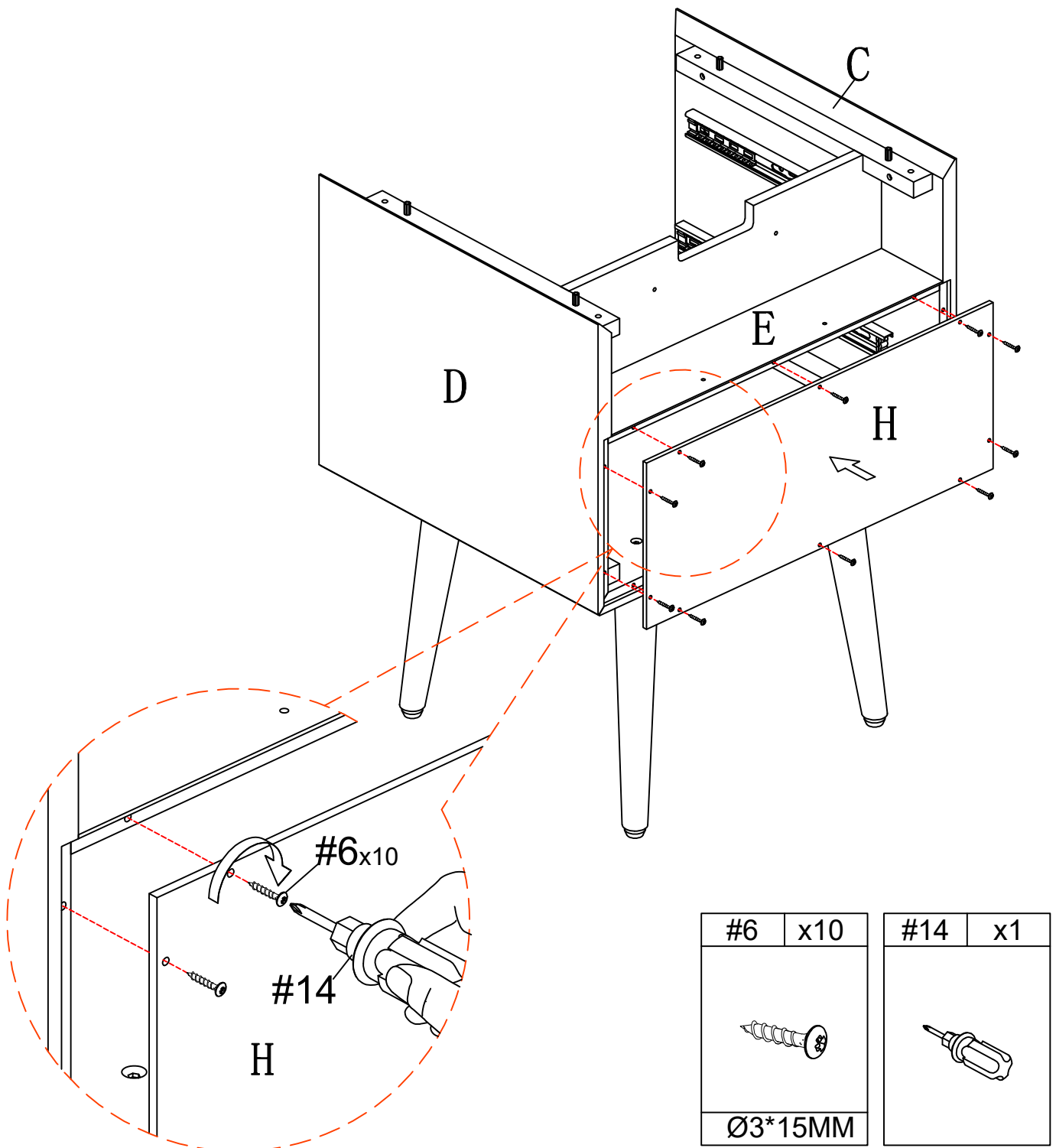

# ASSEMBLY INSTRUCTIONS

## STEP-5

1.insert part (G)into the pre-assembled unit on step 4 make sure all holes aligned and use screw #4 to attach them , tighten screw #4 with screwdriver#14.

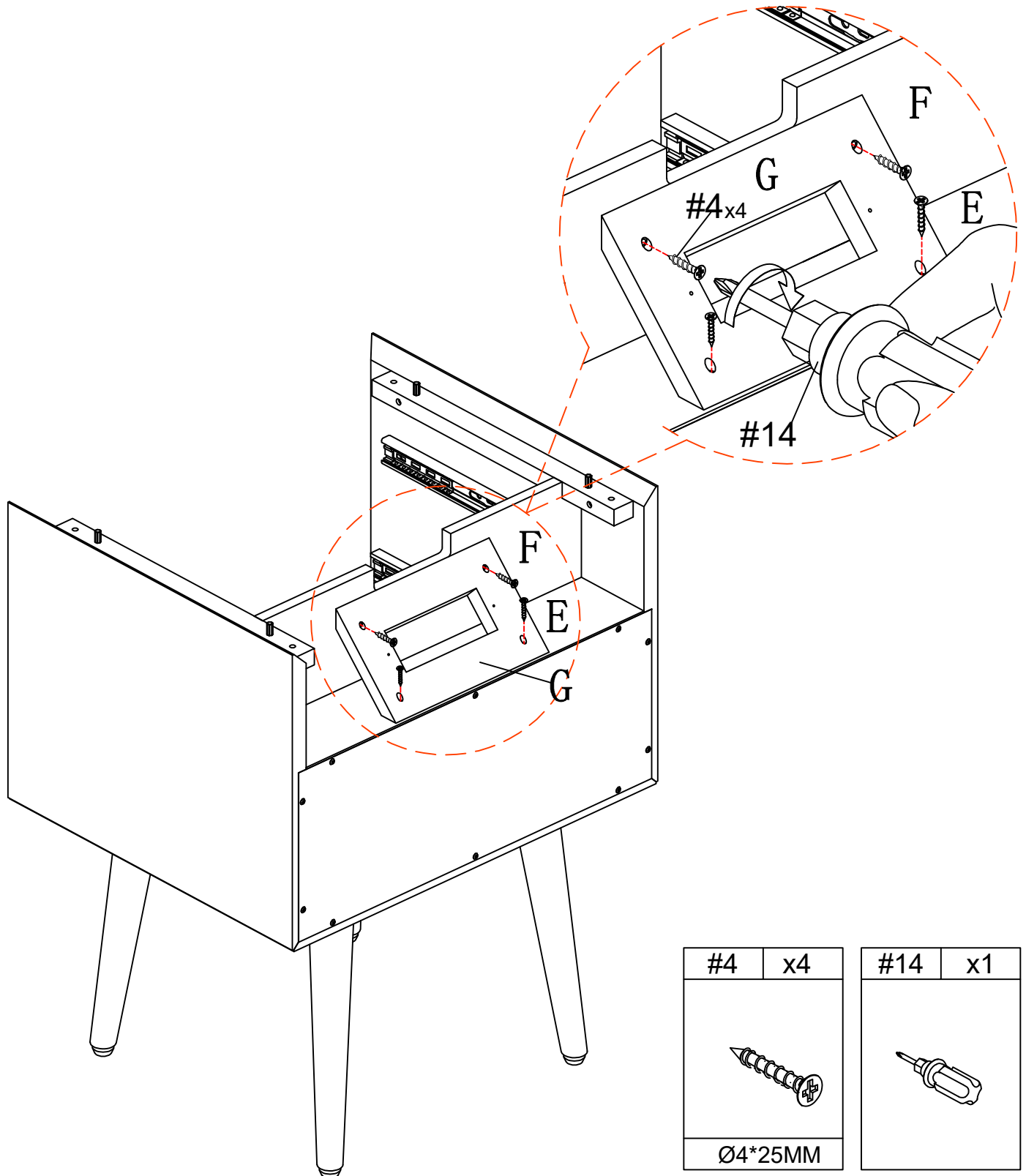

# ASSEMBLY INSTRUCTIONS

## STEP-6

1.insert part #5 into the pre-assembled unit on step 5,make sure all holes aligned and use screw#2 to attach them , tighten screw #2 with screwdriver#14.

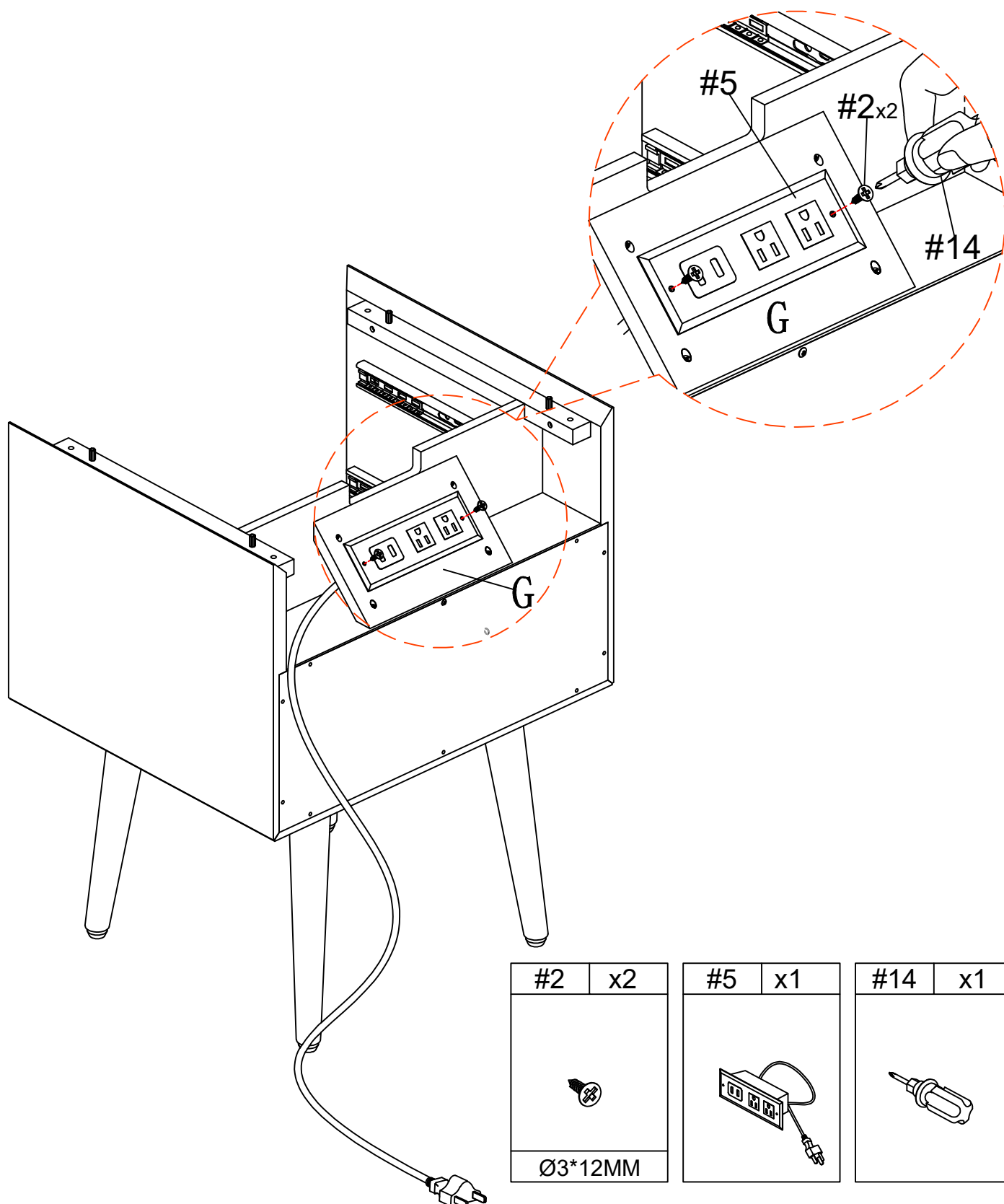

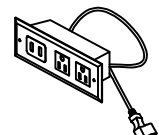
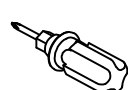

#2	x2	#5	x1	#14	x1
					
Ø3*12MM					

# ASSEMBLY INSTRUCTIONS

## STEP-7

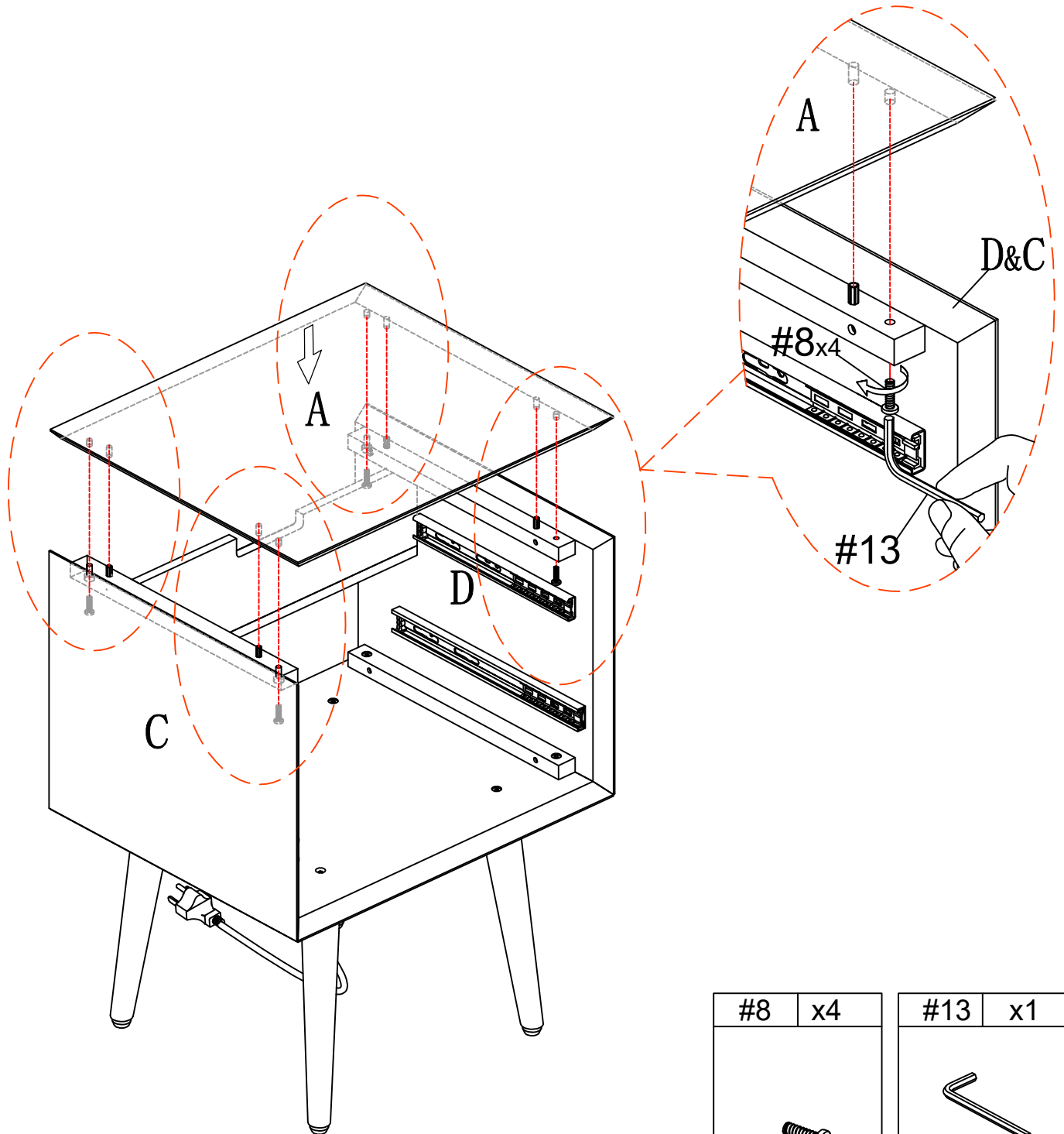
1. Insert top panel (A) into the corresponding hole of pre-assembled unit on step 6, make sure all holes aligned and use Bolt#8 to attach them, tighten bolt#8 with Allen Key #13.



#8	x4	#13	x1
			
Ø6*22MM		M6	

# ASSEMBLY INSTRUCTIONS

## STEP-8

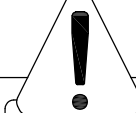
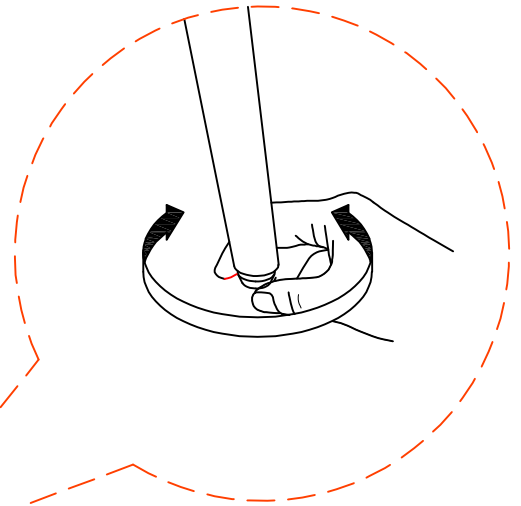
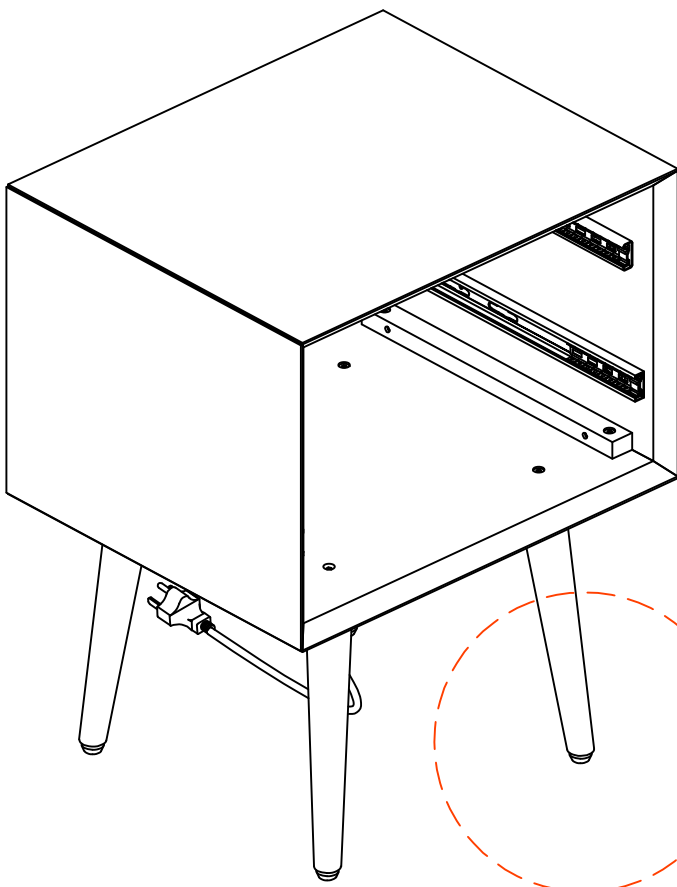

Attention:  
Before the next step, adjust the  
feet of the locker to keep it  
level.

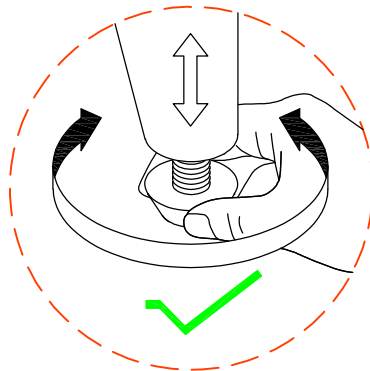
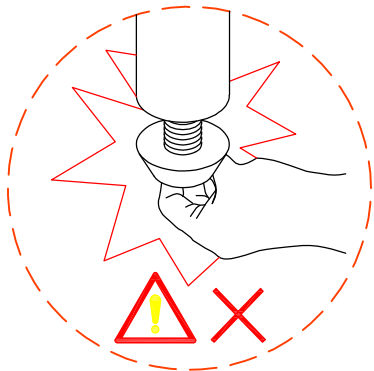

# ASSEMBLY INSTRUCTIONS

## STEP-9

1. Connect part (M&L) to part (O) using screw #4 and tighten it with screwdriver #14.

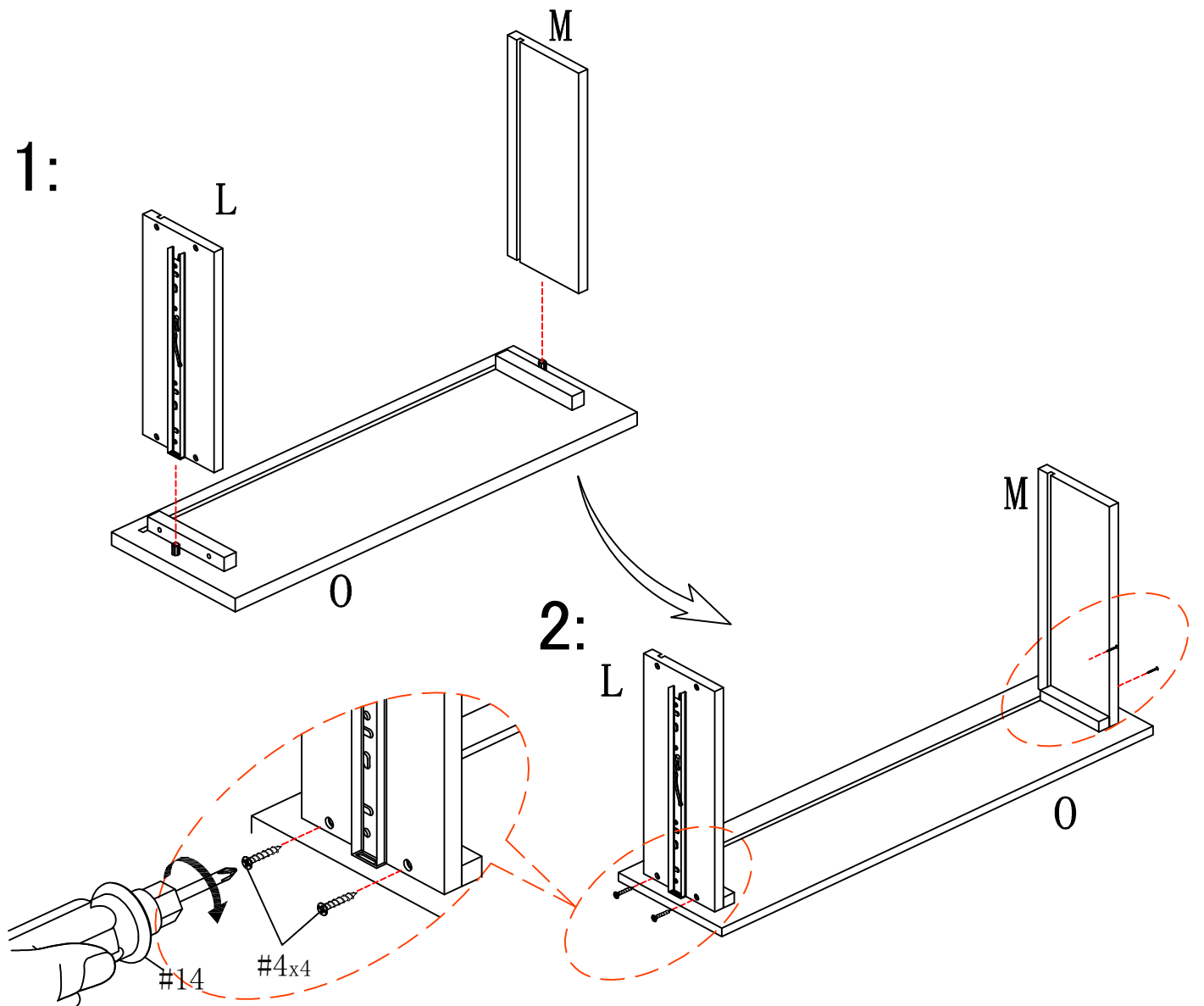

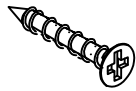
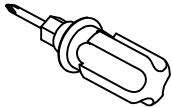
#4	x4	#14	x1
			
Ø4*25MM			

# ASSEMBLY INSTRUCTIONS

## STEP-10

1..Slide in the part (N) into the groove in part (L&M). make sure they are also in groove in part (O).Connect part (M&L) to part (K) using screw #4 and tighten it with screwdriver #14

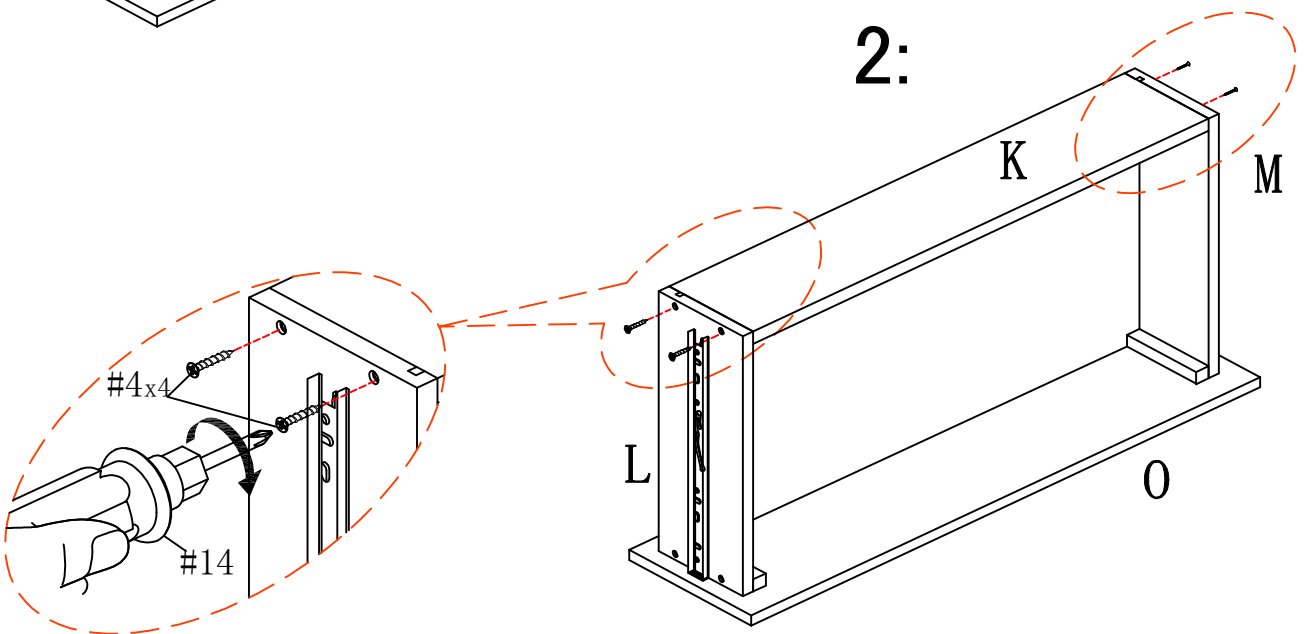
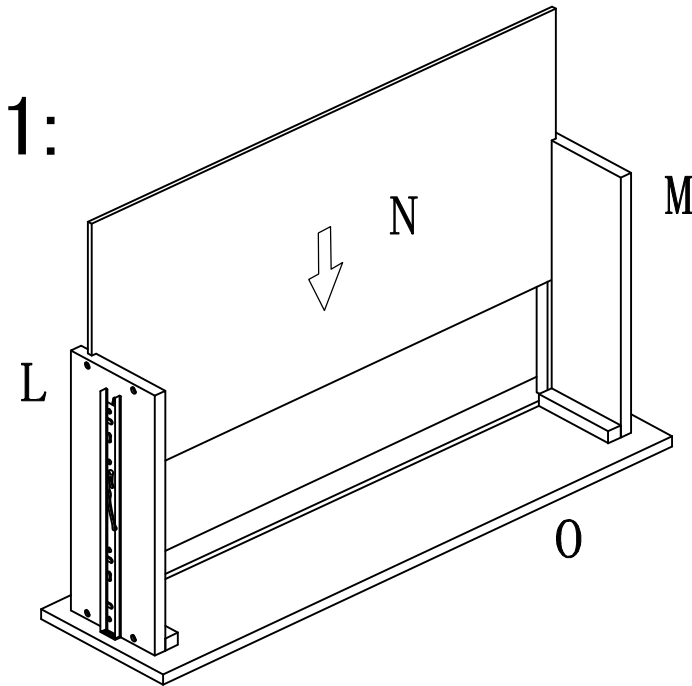

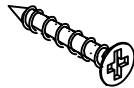
#4	x4
	
Ø4*25MM	

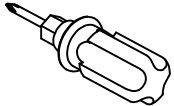
#14	x1
	

# ASSEMBLY INSTRUCTIONS

## STEP-11

1. Connect part (R&S) to part (U) using screw #4 and tighten it with screwdriver #14. Slide in the part (T) into the groove in part (R&S). make sure they are also in groove in part (U).

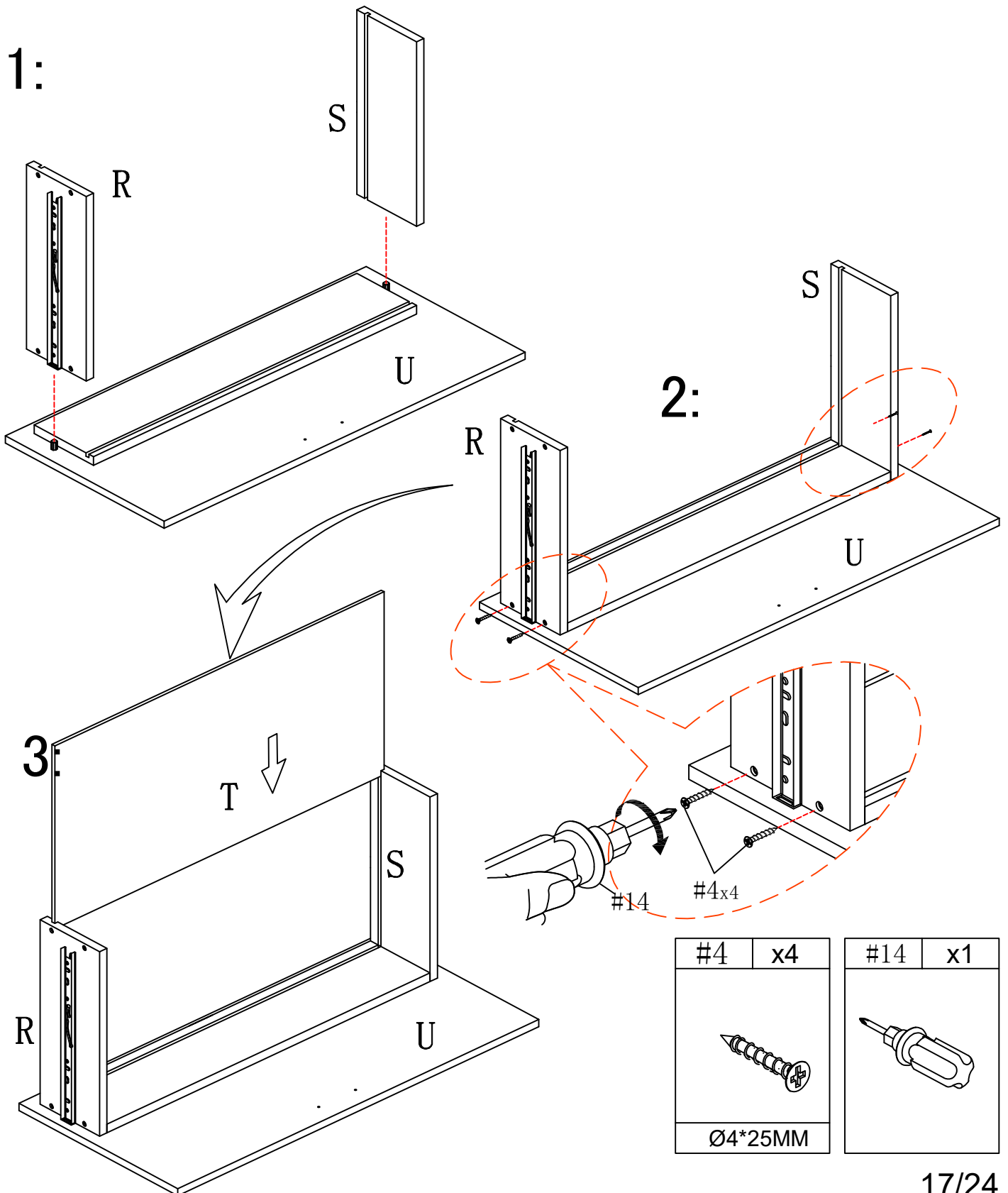



# ASSEMBLY INSTRUCTIONS

## STEP-12

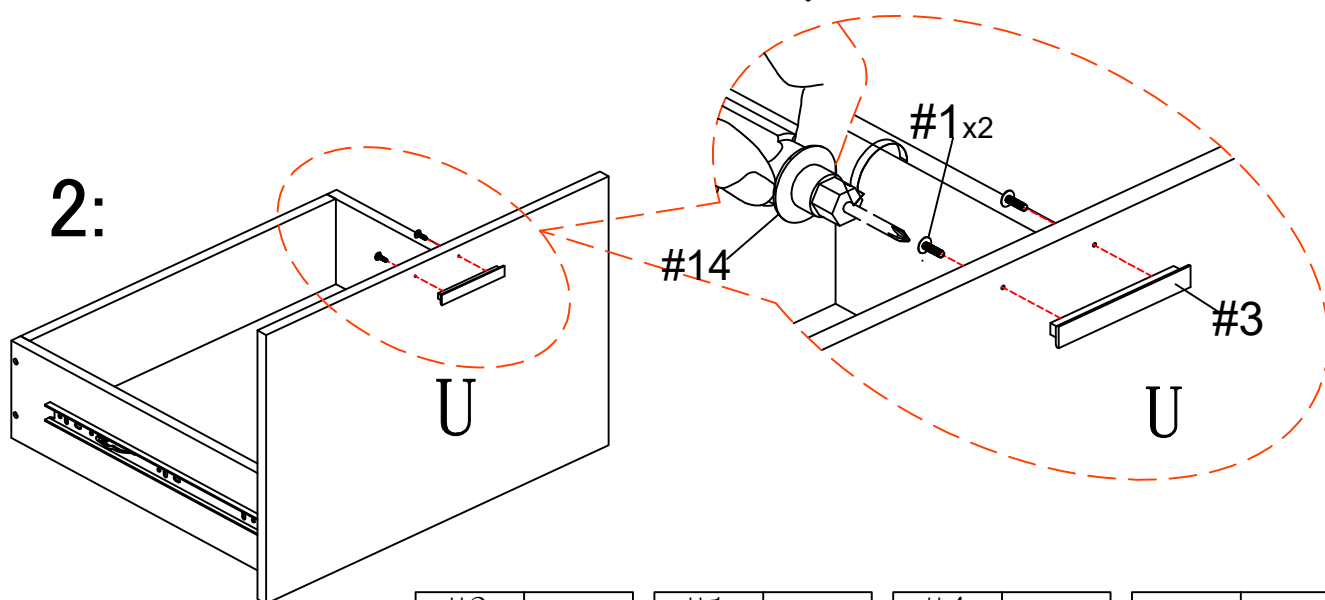
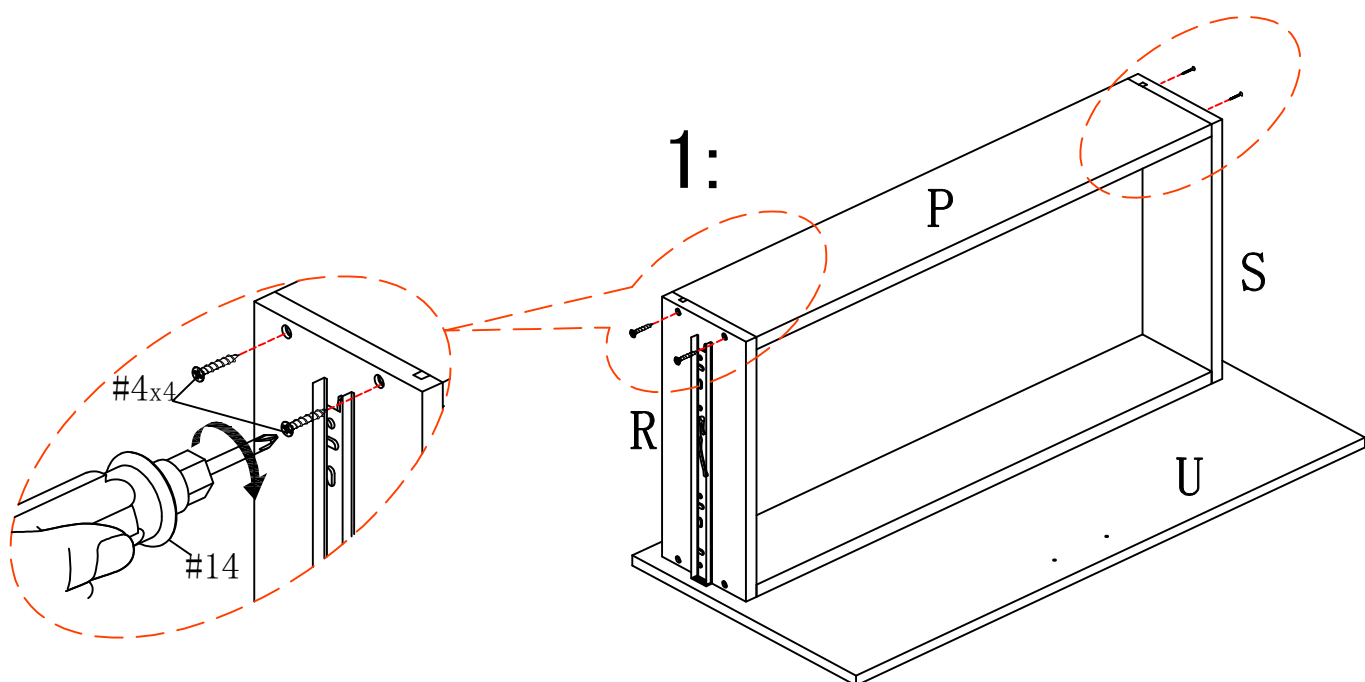
1. Connect the (P) and (R&S) using screw #4 , and tighten it with screwdriver #14.
2. Install handle #3 to panel (U) using screw #1 and tighten it with screwdriver #14.

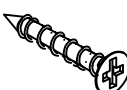
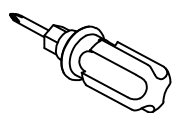

#3	x1	#1	x2	#4	x4	#14	x1
							
		Ø4*15MM		Ø4*25MM			

# ASSEMBLY INSTRUCTIONS

## STEP-13

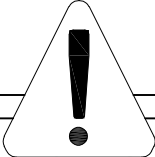
  
Attention: When installing the drawer, slide the steel ball slide rail of side panel to the most front as picture show.

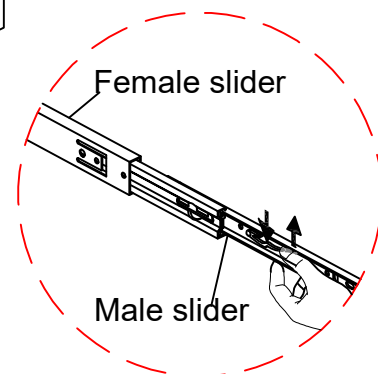
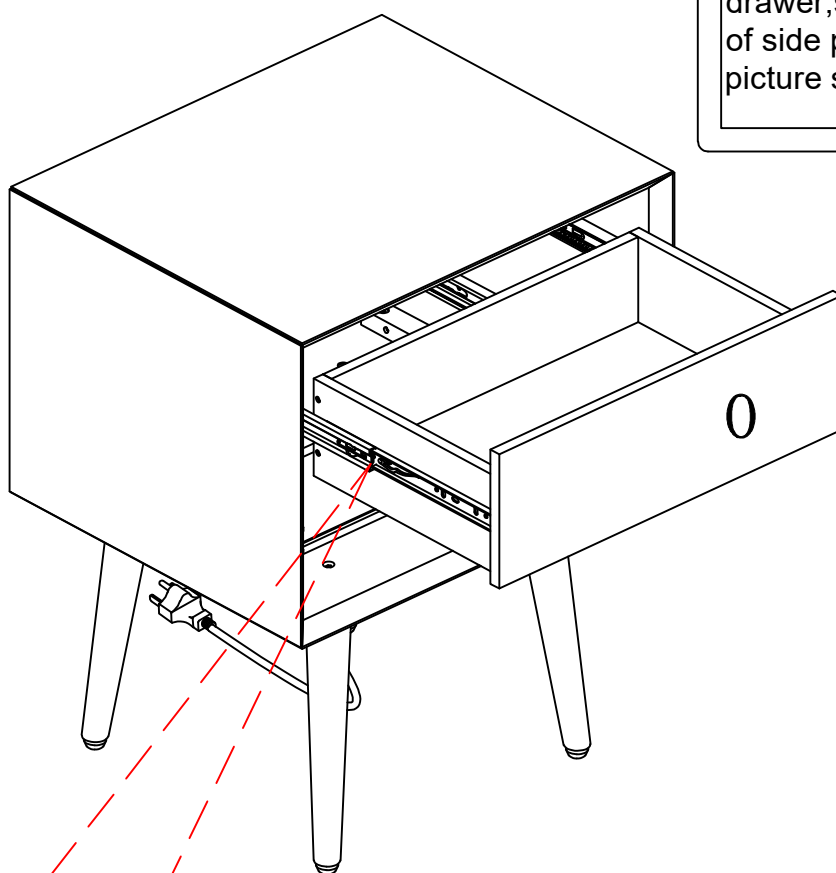

**Schematic diagram of slide rail disassembly**

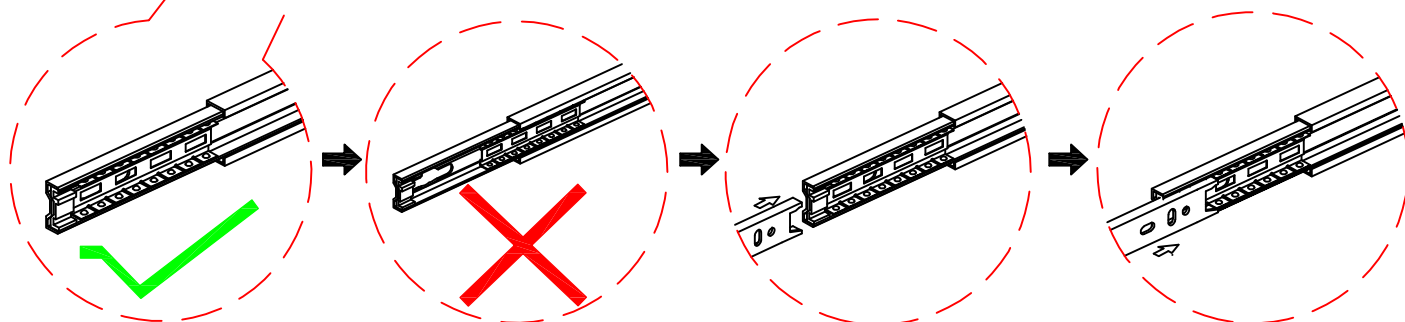

# ASSEMBLY INSTRUCTIONS

## STEP-14

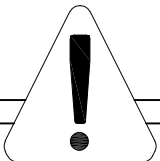
  
Attention: When installing the drawer, slide the steel ball slide rail of side panel to the most front as picture show.

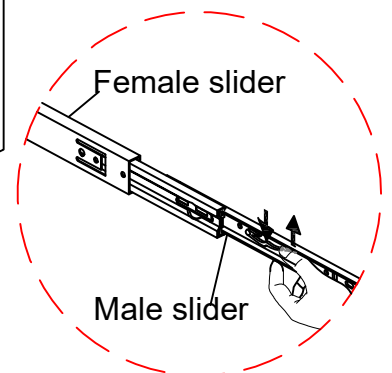
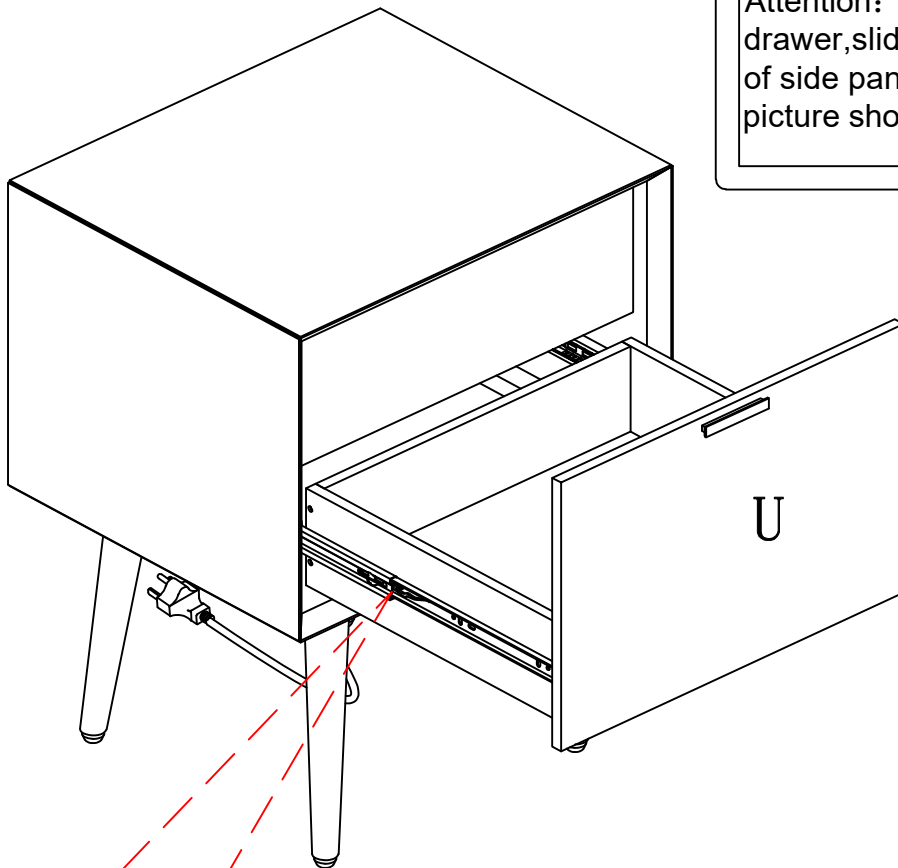

**Schematic diagram of slide rail disassembly**

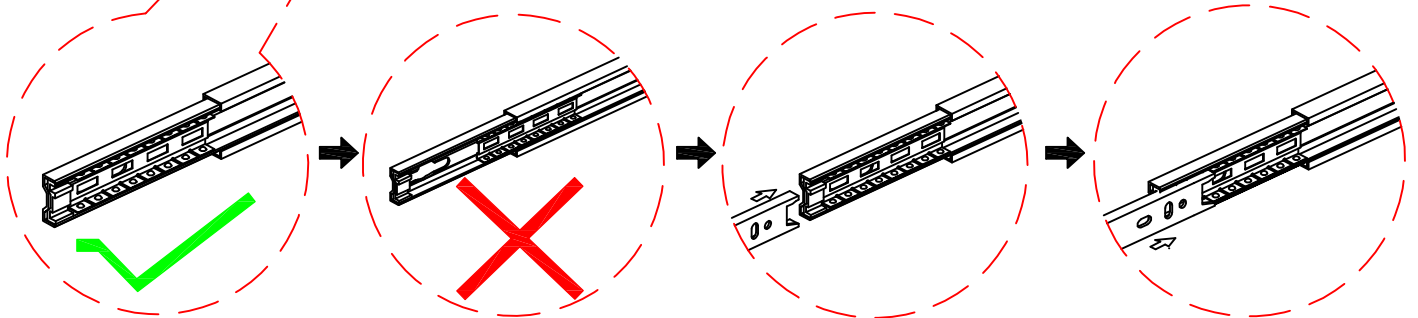

# ASSEMBLY INSTRUCTIONS

## STEP-15

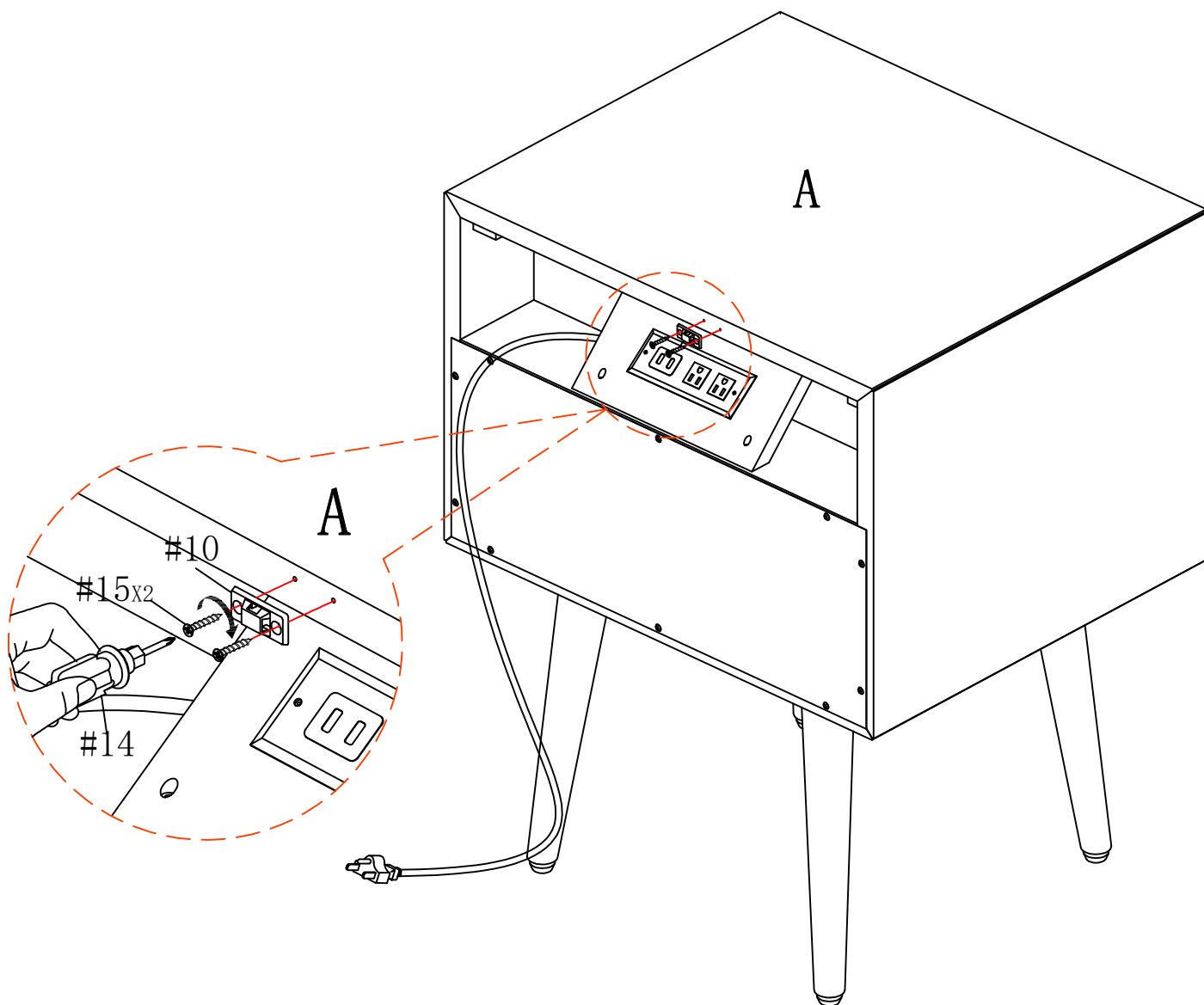

Use screw #15 to attach plastic bracket #10 to panel (A), make sure all holes aligned and tighten screw #15 with screwdriver #14

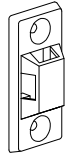
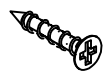
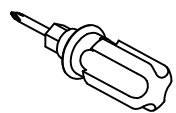

#10	x1	#15	x2	#14	x1
					
		Ø3*20MM			

# ASSEMBLY INSTRUCTIONS

## STEP-16

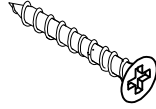
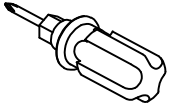
#10	x1	#9	x2	#12	x2	#14	x1
				 Ø4*39MM			

1. Mark the position on the wall, that corresponds to the location of bracket #10 on the panel A; Drill and insert the expandable screw #9 by hammer.
2. Assemble the bracket #10 to the wall. Align the hole in the bracket #10 with the expandable screw #9, use screw #12 to attach it, tighten screw #12 with screwdriver #14.

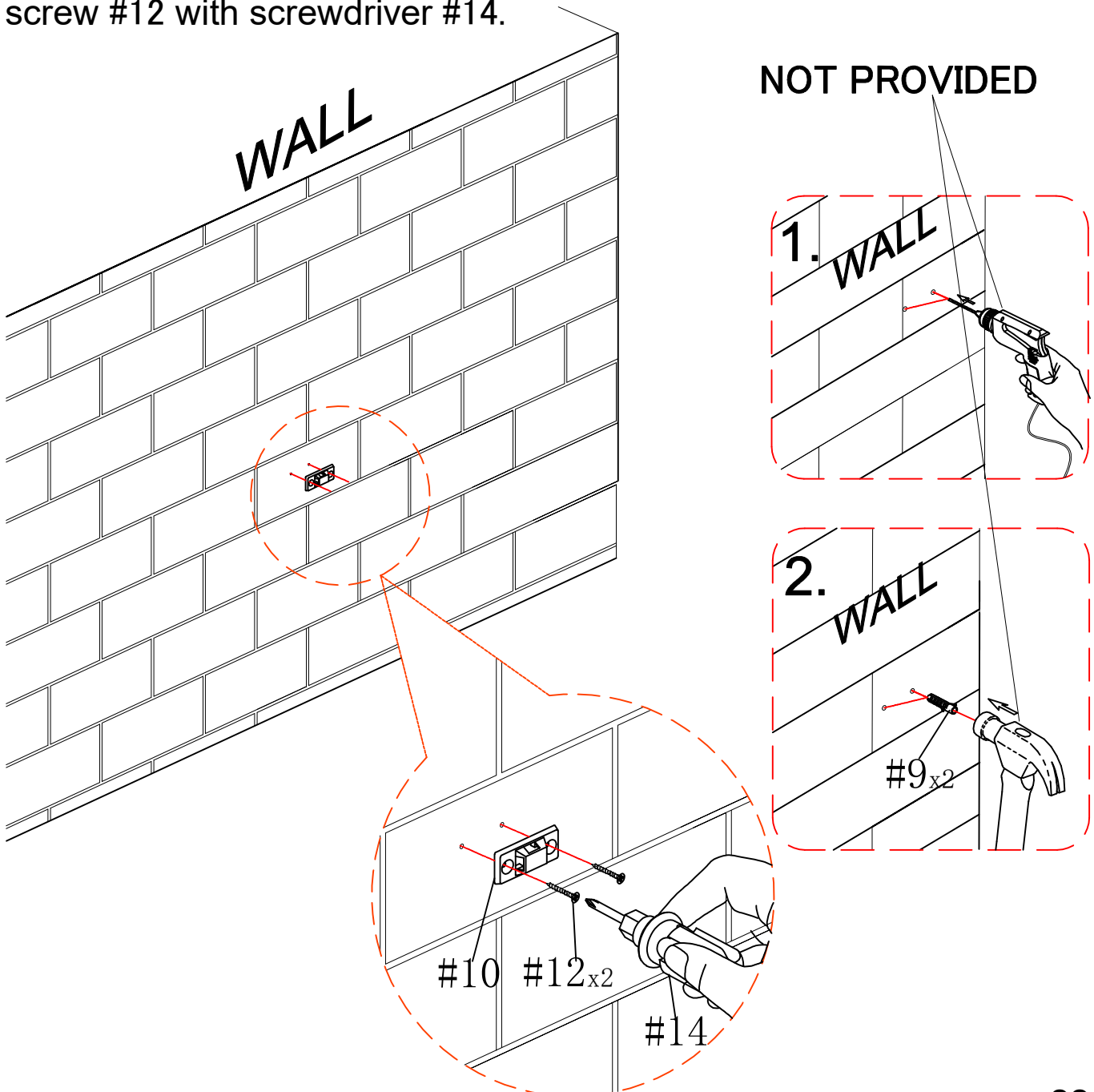

# ASSEMBLY INSTRUCTIONS

## STEP-17

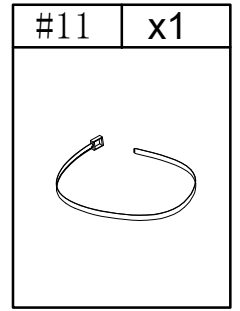

3. Let the plastic belt #11 pass through bracket #10 and pull tightly.

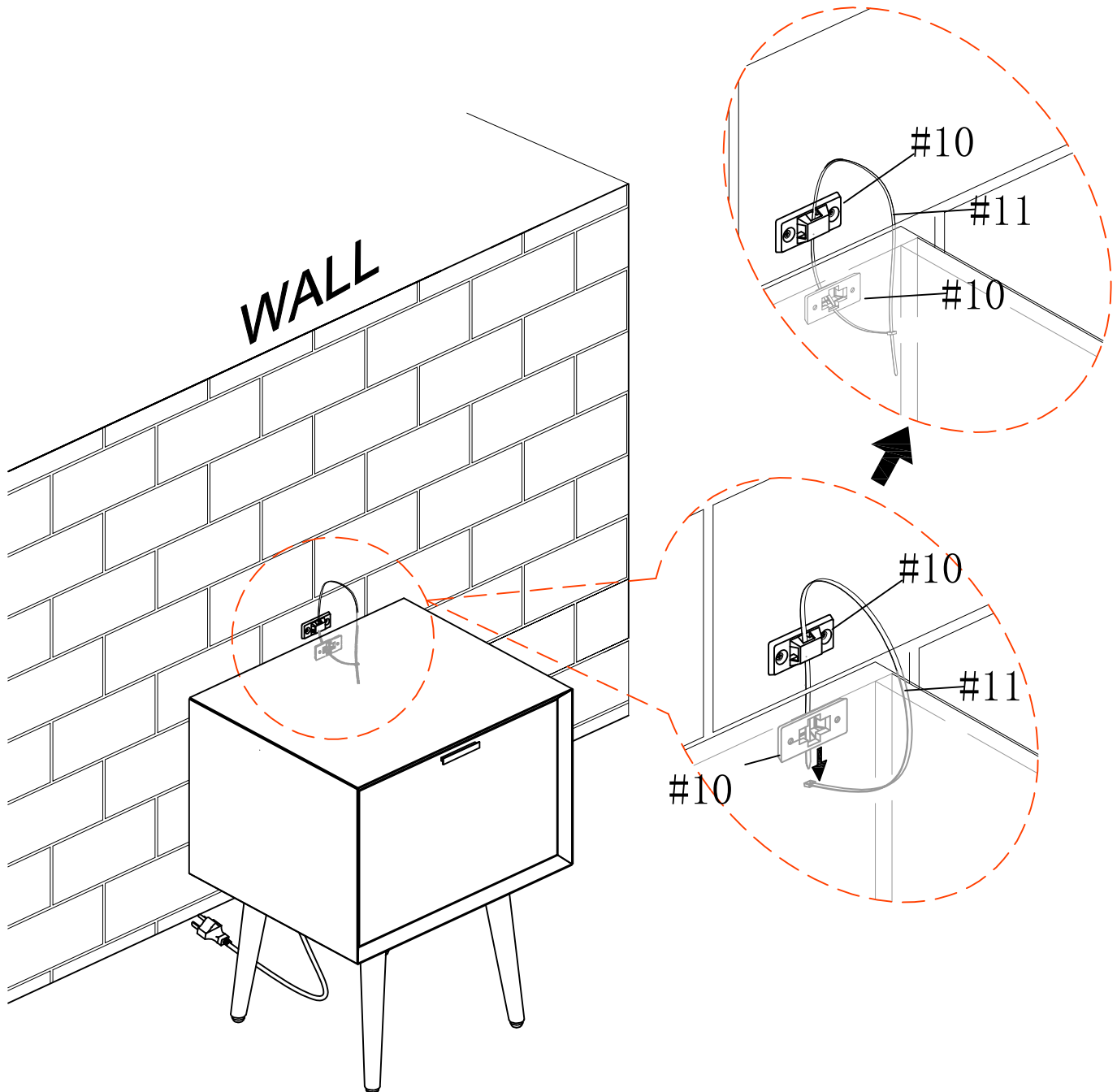

# WARRANTY

1. We strive to offer high-quality products, and we also try our best to satisfy each and every customer that orders from us with product or service as needed.
2. We provide 30 days warranty starting from the time you receive the item. Each customer must provide a record of their order such as the order number, or item receipt for any items that are out of the warranty period you may also still receive.
3. Replacement parts by purchasing them with our company if they are available.

Appreciate your purchasing from us.  
Pop up your life by our furniture piece!