































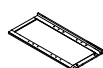

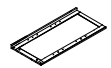





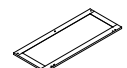

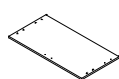

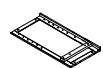
USER'S MANUAL

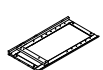
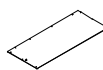
Storage Cabinet

PRODUCT ASSEMBLY Hardware List

A	 6*35mm	28 pcs	H	 3 pcs	O	 2 pcs	
B	 15*10mm	28 pcs	I	 6 pcs	P	 6*50mm	4 pcs
C	 6*30mm	20 pcs	J	 2.5*12mm	34 pcs	Q	 16 pcs
D	 3*12mm	48 pcs	K	 8 pcs	R	 4*16mm	4 pcs
E	 3*14mm	10 pcs	L	 2 pcs	S	 4 pcs	
F	 4*30mm	4 pcs	M	 2 pcs			
G	 4*40mm	6 pcs	N	 4*25mm	4 pcs		

Parts List

1		1 pc	14		1 pc
2		1 pc	15		4 pcs
3		1 pc	16		1 pc
4		1 pc	17		1 pc
5		1 pc	18		1 pc
6		2 pcs	19		1 pc
7		1 pc	20		1 pc
8		1 pc	21		2 pcs
9		1 pc	22		2 pcs
10		1 pc	23		2 pcs
11		1 pc	24		1 pc
12		1 pc	25		1 pc
13		1 pc	26		

PRODUCT ASSEMBLY

Part List Assembly Overview

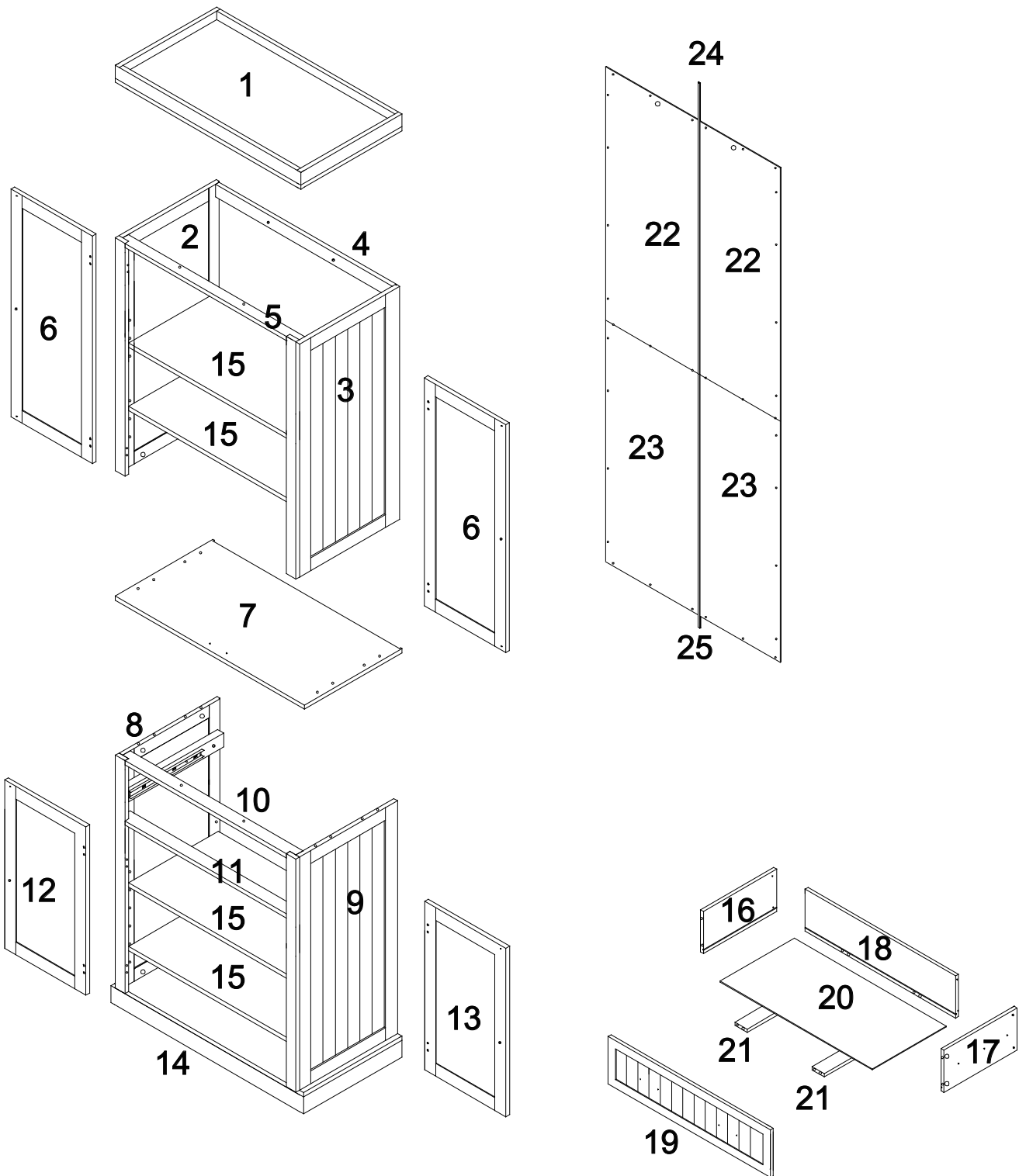

PRODUCT ASSEMBLY

Step 1

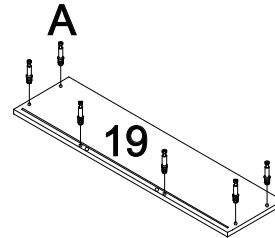
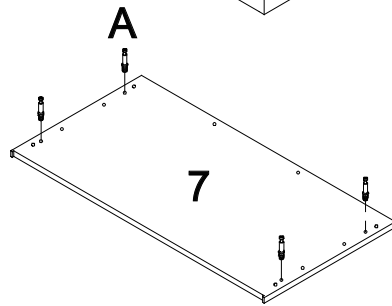
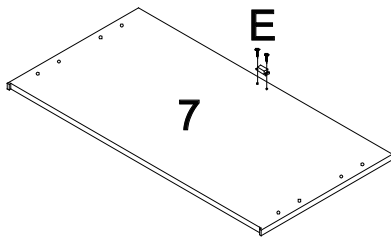
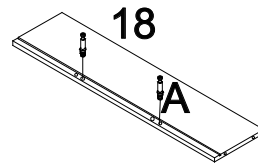
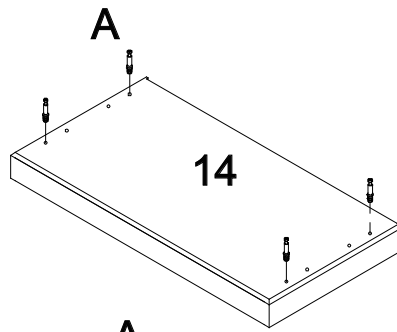
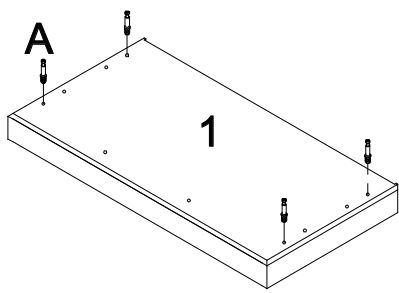

A		28 pcs
D		26 pcs
E		6 pcs
H		3 pcs
I		6 pcs
K		8 pcs
L1		2 pcs

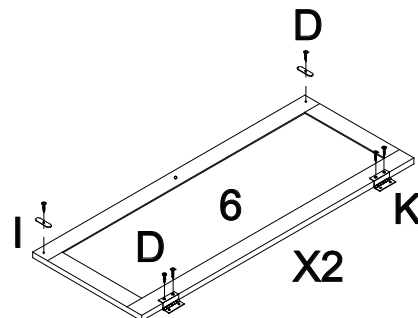
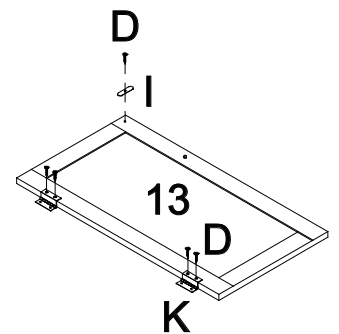
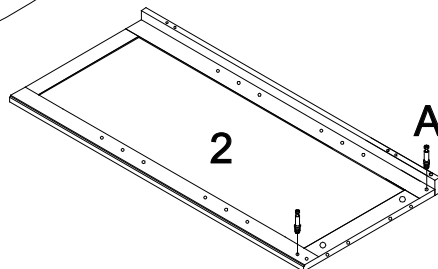
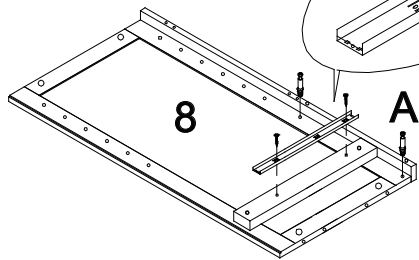
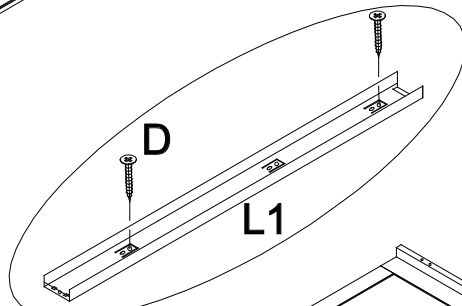
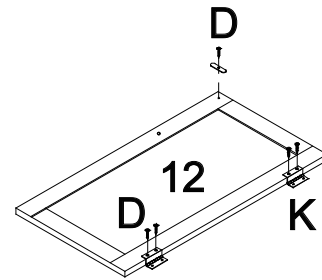
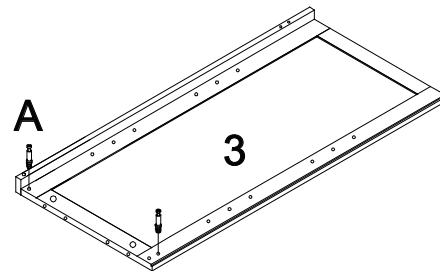
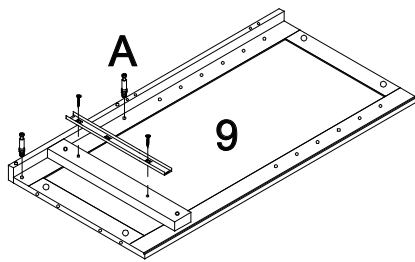
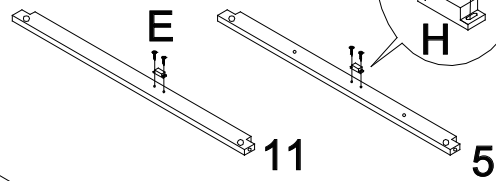

PRODUCT ASSEMBLY

Step 2

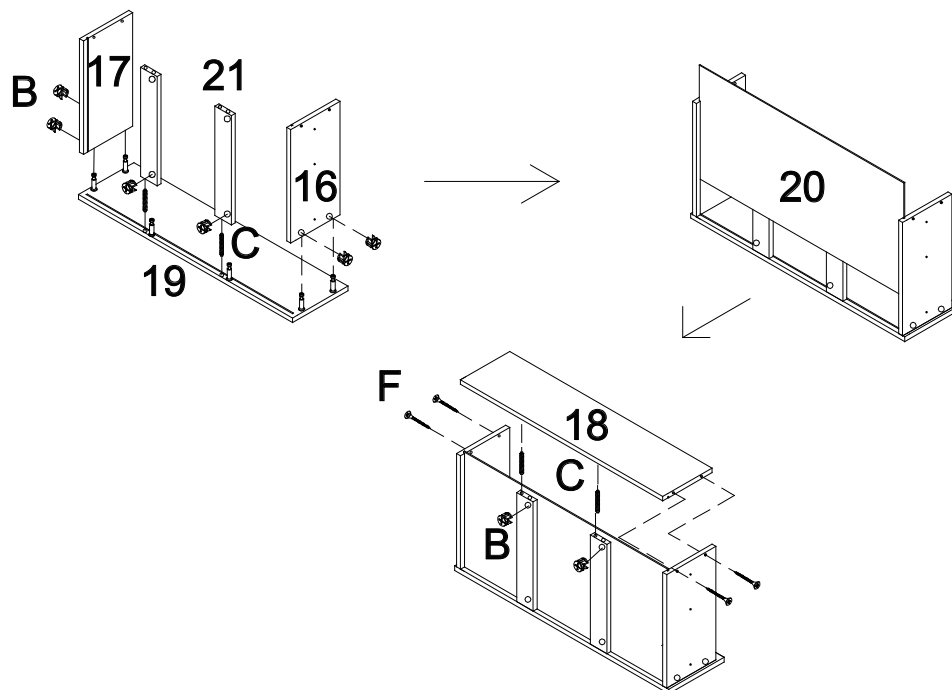

B		8 pcs
C		4 pcs
F		4 pcs

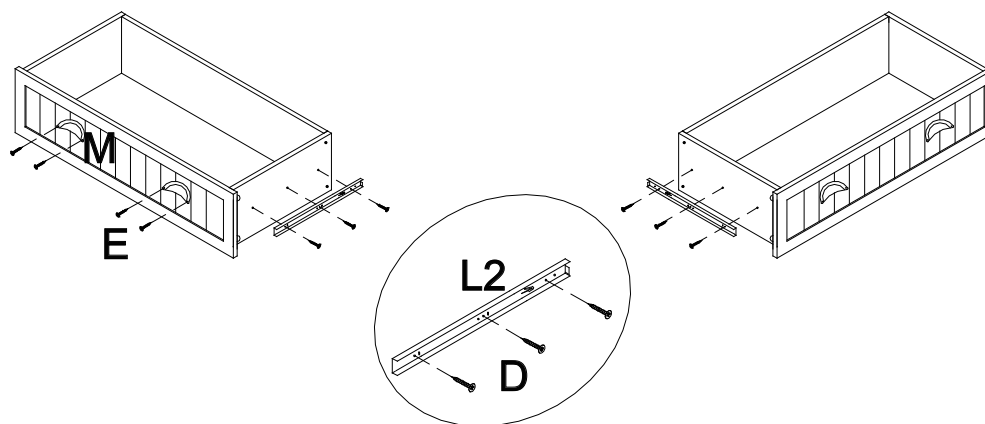

Step 3



D		6 pcs
E		4 pcs
L2		2 pcs
M		2 pcs



PRODUCT ASSEMBLY

Step 4

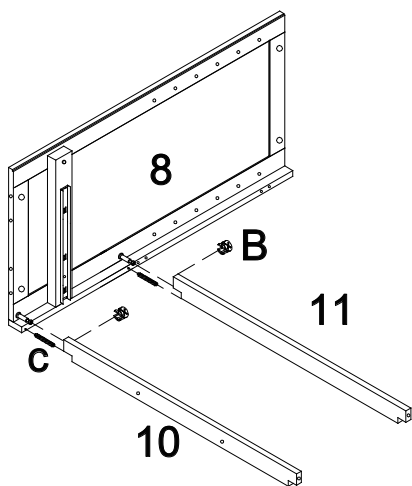
B		2 pcs
C		2 pcs



Step 5

B		2 pcs
C		2 pcs

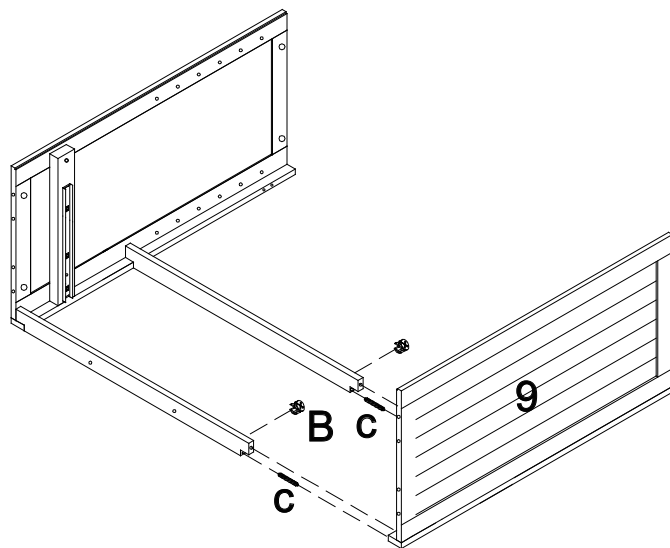

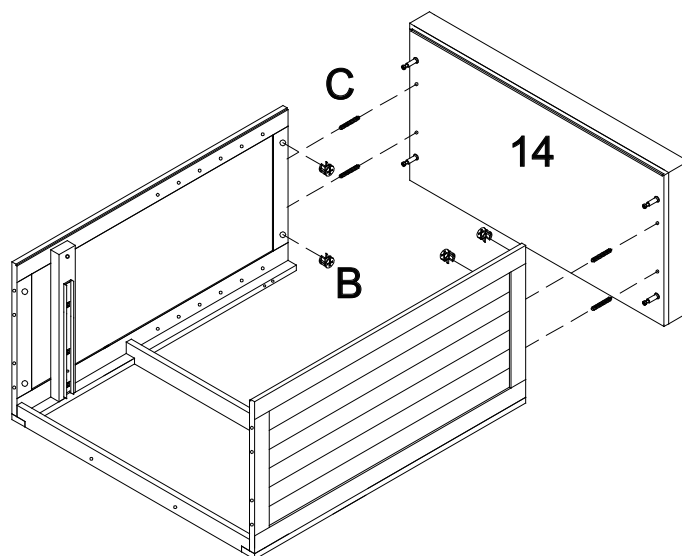

Step 6

B		4 pcs
C		4 pcs



PRODUCT ASSEMBLY

Step 7

B		2 pcs
C		2 pcs

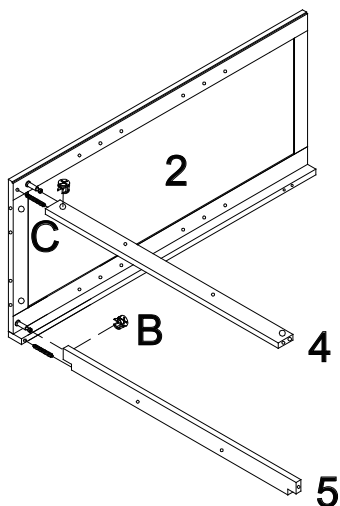



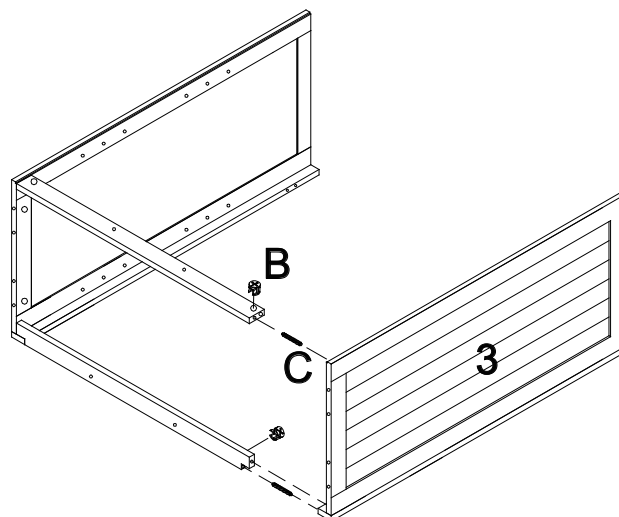

Step 8

B		2 pcs
C		2 pcs



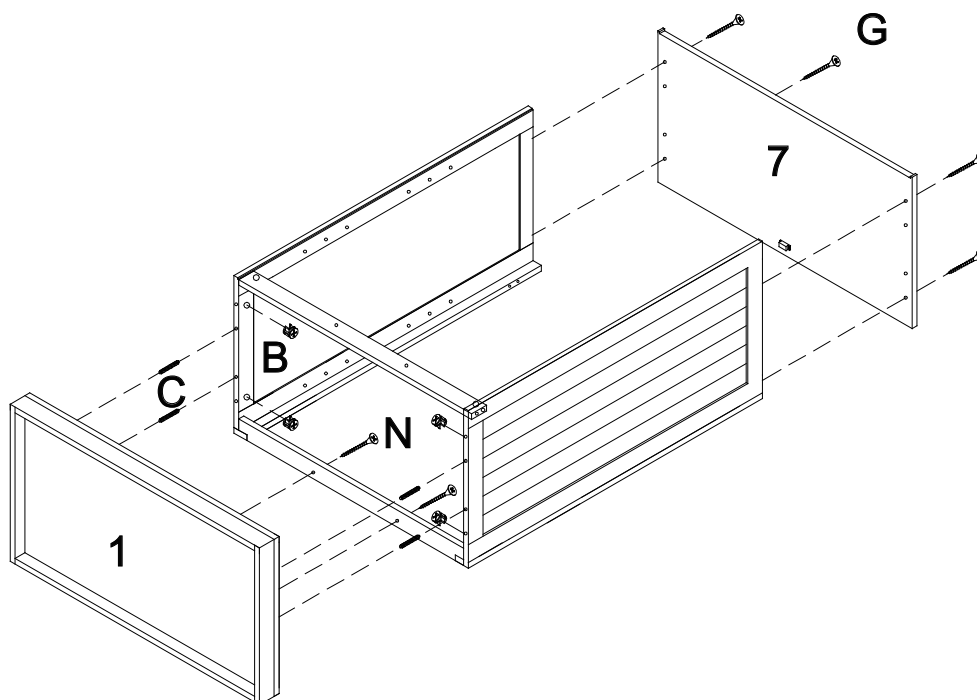

Step 9

B		4 pcs
C		4 pcs
G		4 pcs
N		2 pcs



PRODUCT ASSEMBLY

Step 10

B		4 pcs
N		2 pcs
P		4 pcs

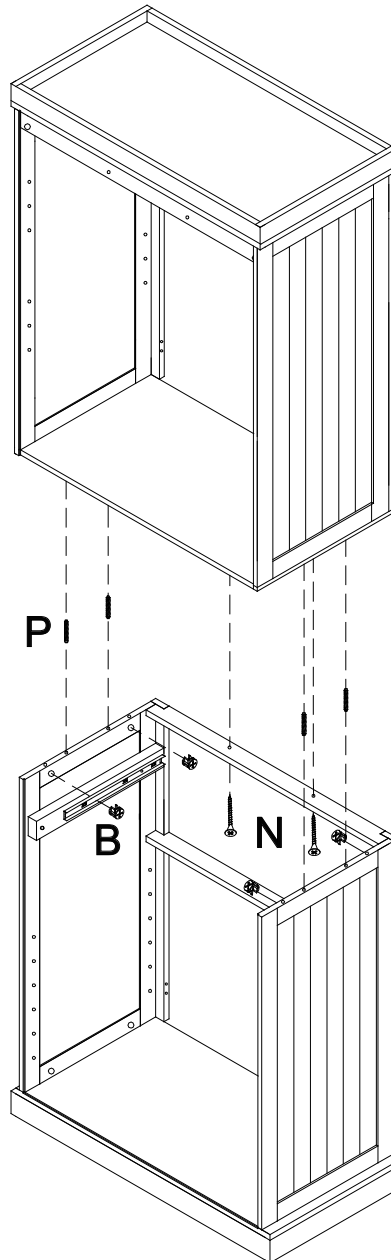

PRODUCT ASSEMBLY

Step 11

J		17 pcs
---	---	--------

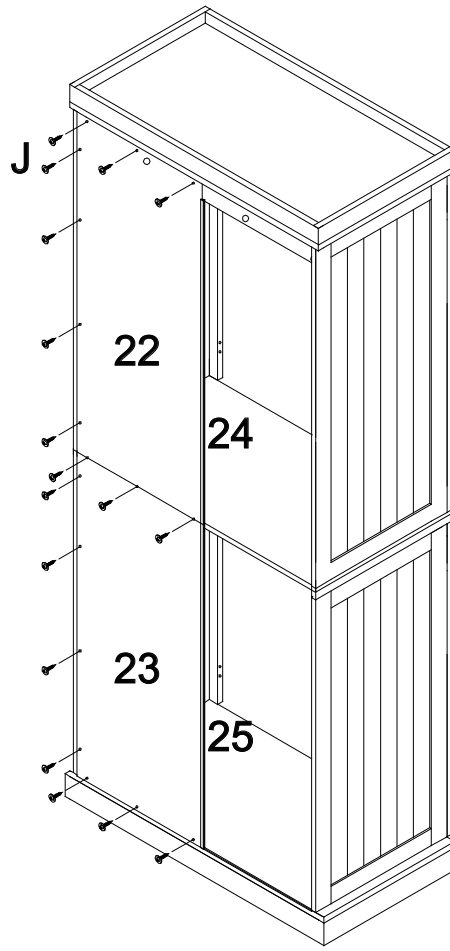

Step 12

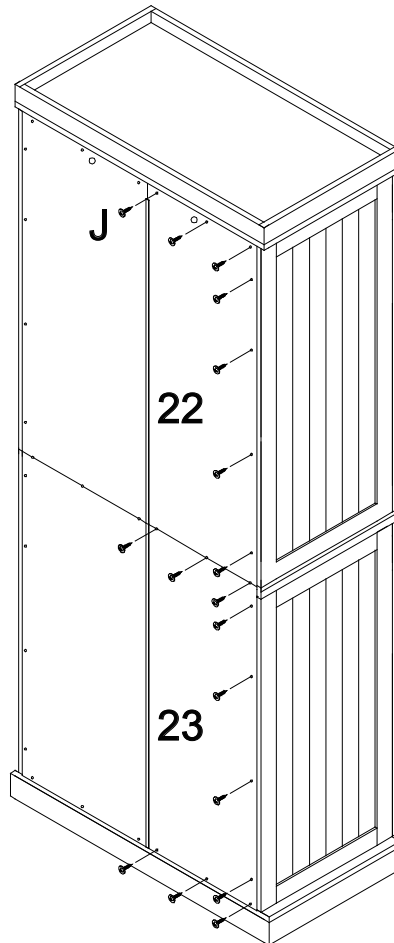

J		17 pcs
---	---	--------



PRODUCT ASSEMBLY

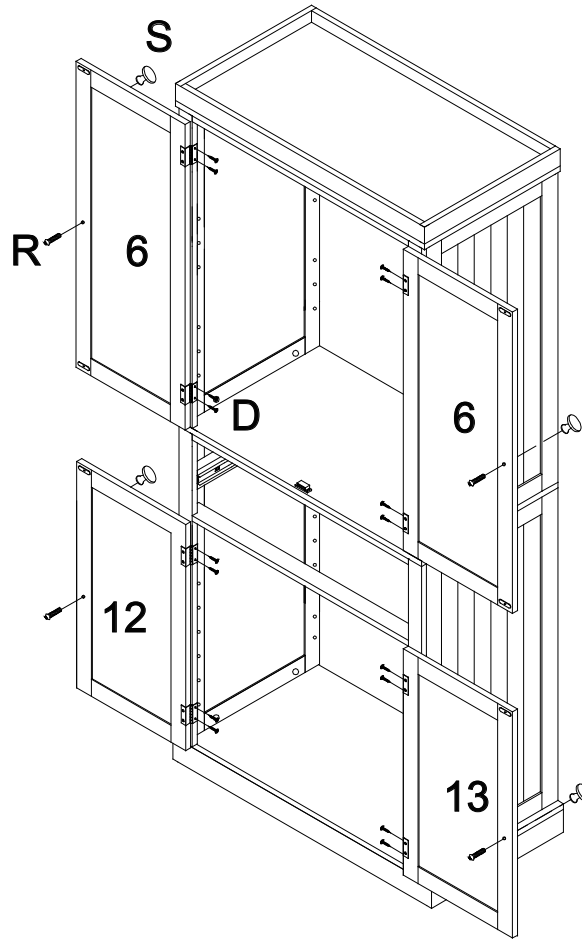

Step 13

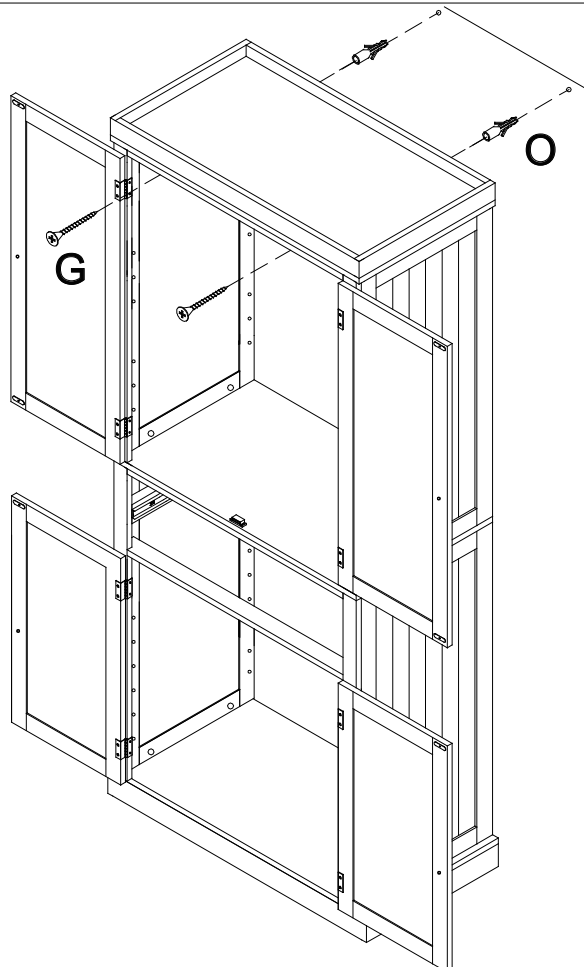

D		16 pcs
R		4 pcs
S		4 pcs

Step 14



G		2 pcs
O		2 pcs

PRODUCT ASSEMBLY

Step 15

Q		16 pcs
---	---	--------

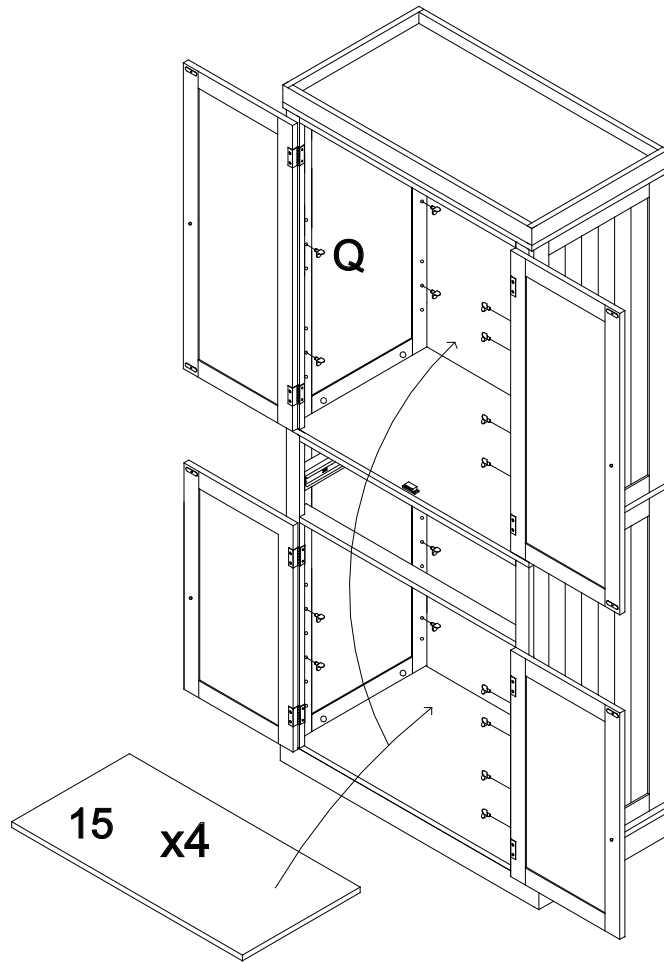

Step 16

