

EN:

CAUTION:

- * Before using the chair, check to ensure that all bolts are fully tightened.
- * Lubricate all parts and tighten all bolts every 6 months or whenever needed.

NOTE: 1.All bolts are 100% tightened.

Leave the dining chair in a shady outside for 1-2 days.

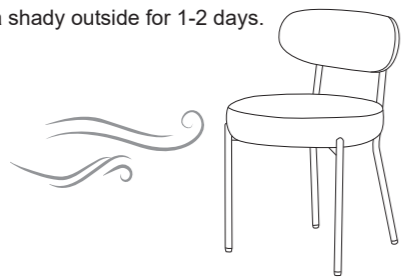

For longer use
Re-tighten bolts every 6 months by using the enclosed allen-key.
*Using an electric drill can damage the chair. Please re-tighten bolts manually.



ES:

PRECAUCIÓN:

- * Antes de usar la silla, compruebe que todos los tornillos estén completamente apretados.
- * Lubrique todas las piezas y apriete los tornillos cada 6 meses o siempre que sea necesario.

NOTA: 1. Todos los tornillos están al 100% apretados.

Deje la silla de comedor en el exterior, a la sombra, durante 1-2 días.



Para un uso prolongado
Vuelva a apretar los tornillos cada 6 meses utilizando la llave Allen incluida.
*El uso de un taladro eléctrico puede dañar la silla. Vuelva a apretar los tornillos manualmente.

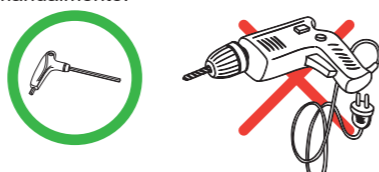

FR:

ATTENTION :

- * Avant d'utiliser la chaise, vérifiez que tous les boulons sont bien serrés.
- * Lubrifiez toutes les pièces et resserrez tous les boulons tous les 6 mois ou si nécessaire.

REMARQUE : 1.Tous les boulons sont serrés à 100 %.

Laissez la chaise de salle à manger à l'extérieur à l'ombre pendant 1 à 2 jours.

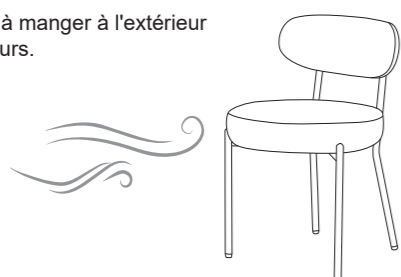

Pour une utilisation prolongée
Resserrez les boulons tous les 6 mois à l'aide de la clé Allen fournie.
*L'utilisation d'une perceuse électrique peut endommager la chaise. Veuillez resserrez les boulons manuellement.

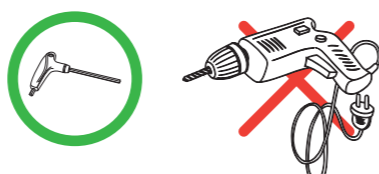

Safety Information / Información de seguridad / Informations Relatives à la Sécurité



**INSTRUCTION MANUAL
MANUAL DE INSTRUCCIONES
MANUEL D'INSTRUCTIONS**

C-6209

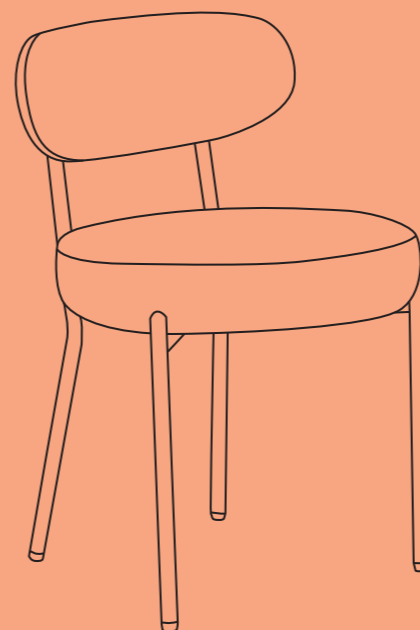

- ✉ HJ-Customer-Service@outlook.com
☎ (909)637-7665 | (909)637-7593
EST 9:00AM--17:00PM
- ✉ HJ-Customer-Service@outlook.com
☎ (909)637-7665 | (909)637-7593
9:00-17:00 (EST)
- ✉ HJ-Customer-Service@outlook.com
☎ (909)637-7665 | (909)637-7593
9h00--17h00 HNE

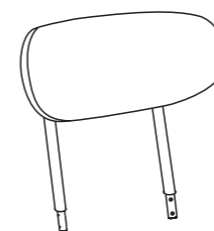

(A)*1



(B)*1

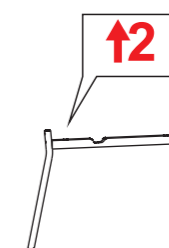

(C)*1

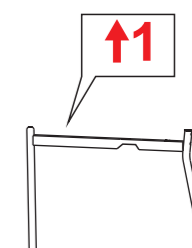

(D)*1



M6x47mm

(E)*4



M6x12mm

(F)*4



M6x30mm

(G)*1



(H)*1

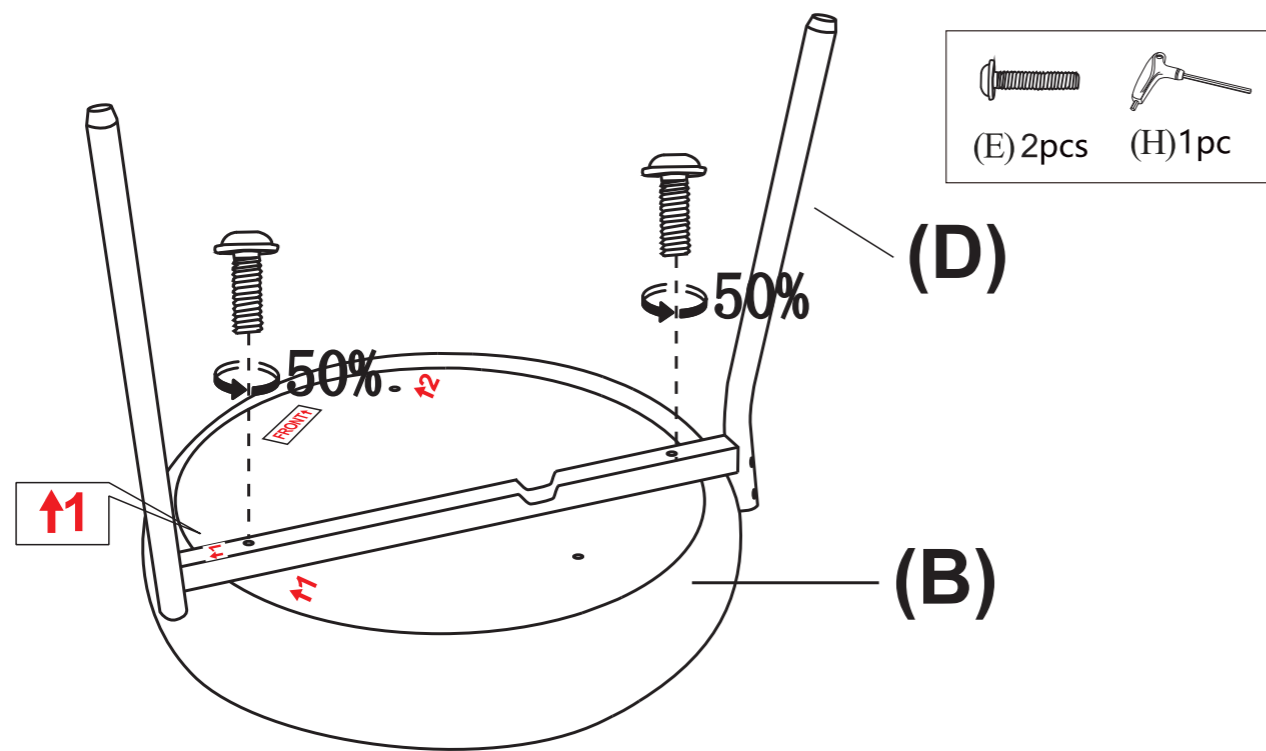

- 1** EN: **NOTE:** The bolts are only tightened 50%.
 ES: **NOTA:** Los tornillos están apretados solo al 50%.
 FR: **REMARQUE :** Les Boulons ne sont serrés qu'à 50 %.

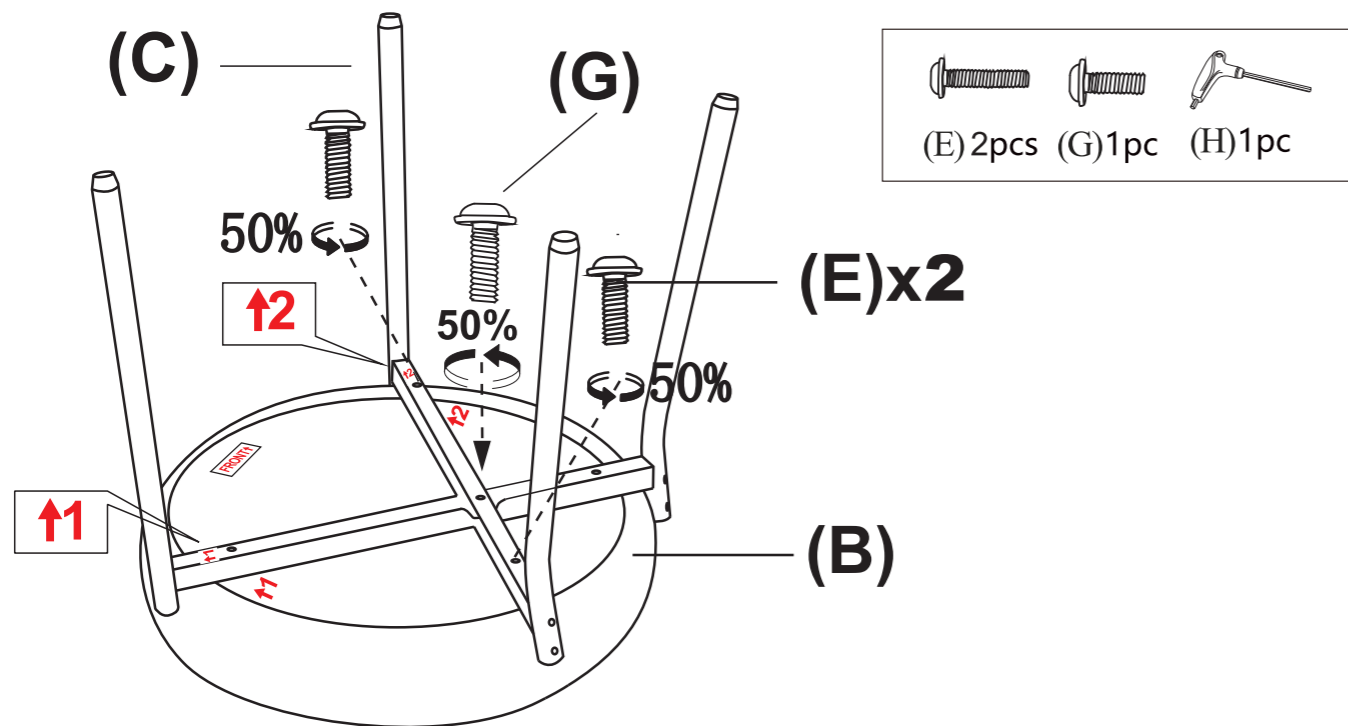

- 2** EN: **NOTE:** The bolts are only tightened 50%.
 ES: **NOTA:** Los tornillos están apretados solo al 50%.
 FR: **REMARQUE :** Les Boulons ne sont serrés qu'à 50 %.

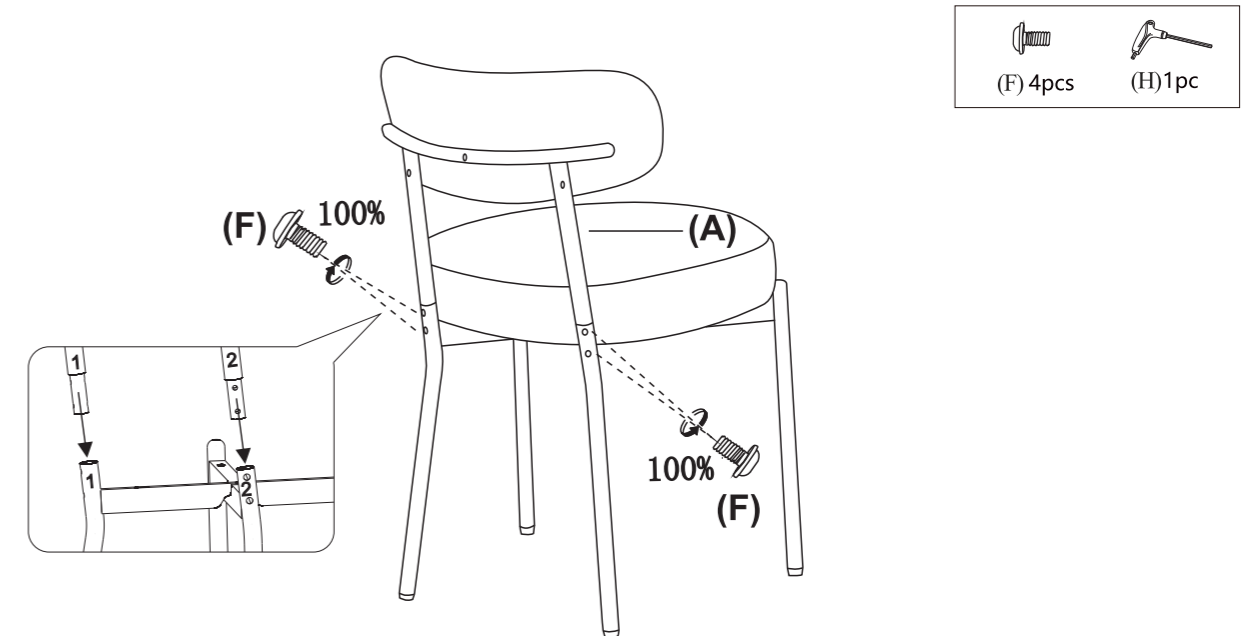

- 3** EN: **NOTE:** The bolts are only tightened 50%; When installing, please match the numbers on the backrest and legs.
 ES: **NOTA:** Los tornillos están apretados solo al 50%; Al instalar, asegúrese de hacer coincidir los números del respaldo y las patas.
 FR: **REMARQUE :** Les boulons ne sont serrés qu'à 50 % ; lors de l'installation, veuillez faire correspondre les numéros sur le dossier et les pieds.

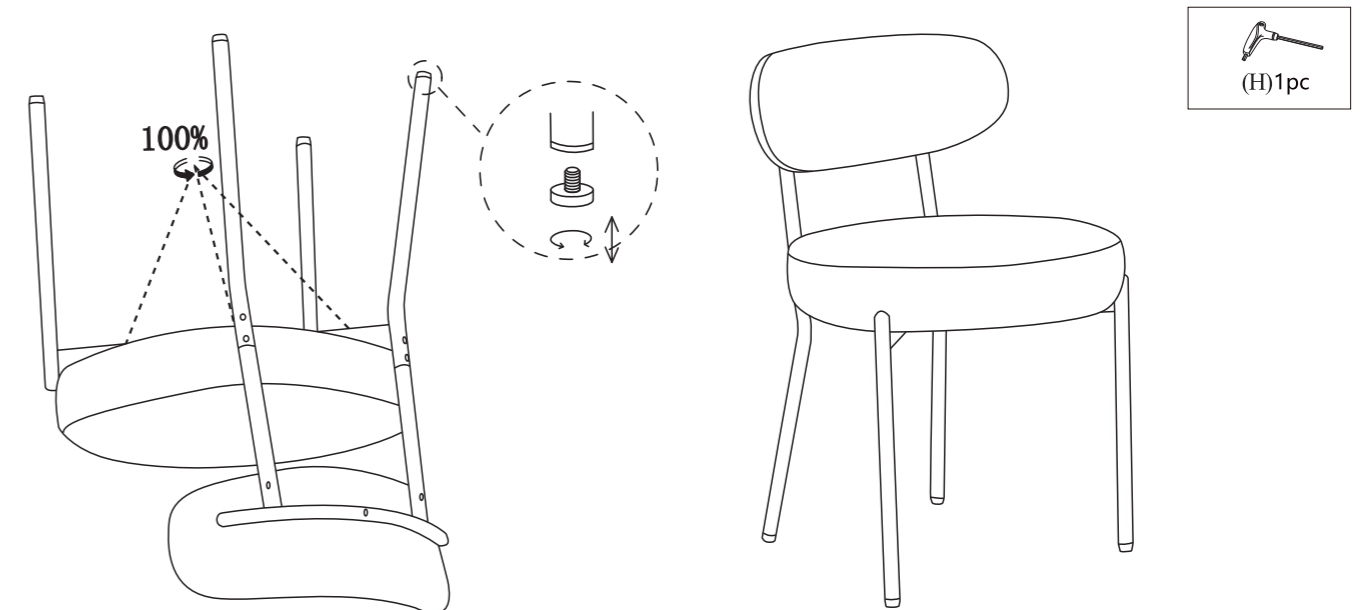

- 5** EN: **NOTE:** Tighten all bolts 100% tightly.
 ES: **NOTA:** Apriete todos los tornillos al 100%.
 FR: **REMARQUE :** Tous les boulons sont serrés à 100 %.