

WIRE SHELVING INSTRUCTION

Option A: 6-Tier Wire Shelving Assembly Steps:

Two Option Assembly Way:

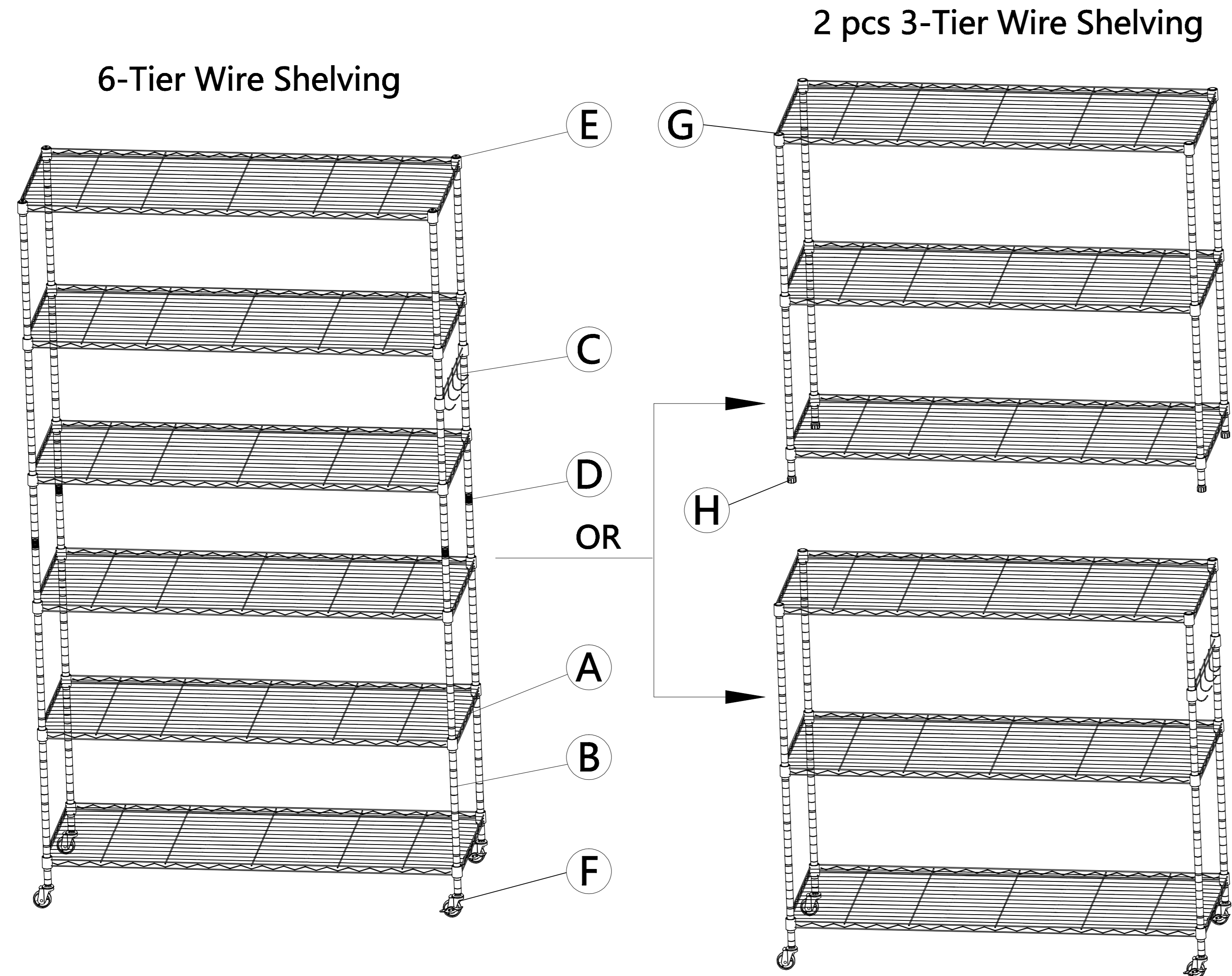

1 Screw the Caster(F) or The Leveling Foot(G) into the bottom of four Poles(C) and fastened by wrench, Snap the Plastic Clips(D) into the grooves of four pole at your desired position. Make sure the arrow of plastic clips are pointed up.

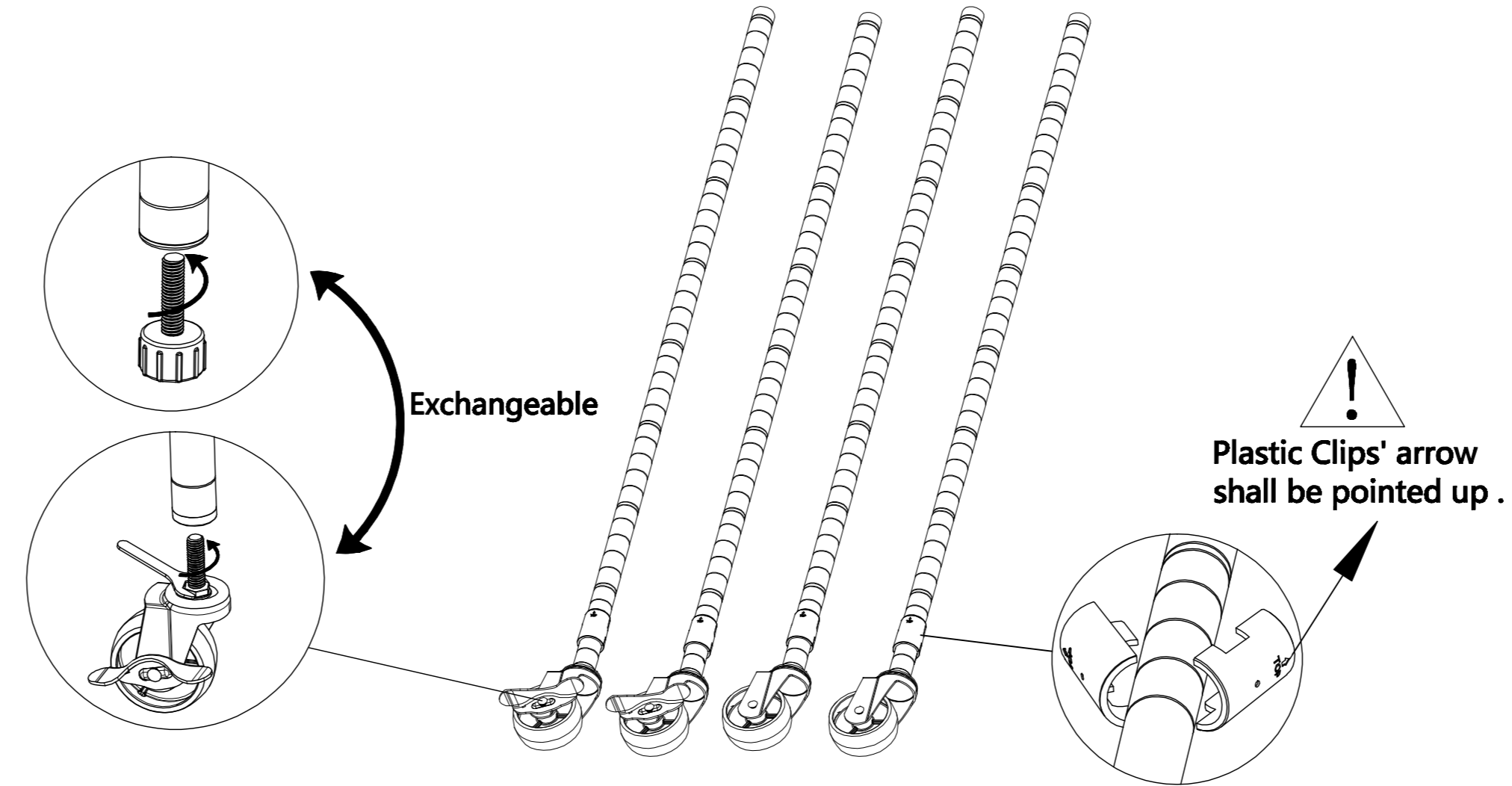

2 Please make sure Wire Shelf(A) the correct way up. Hold the wire shelf on its side and slide the top of four lower poles through the bottom of each wire shelf at its corners until there us Snug fit. After 4 poles have been slid through the shelf collar holes, set the shelf upright.

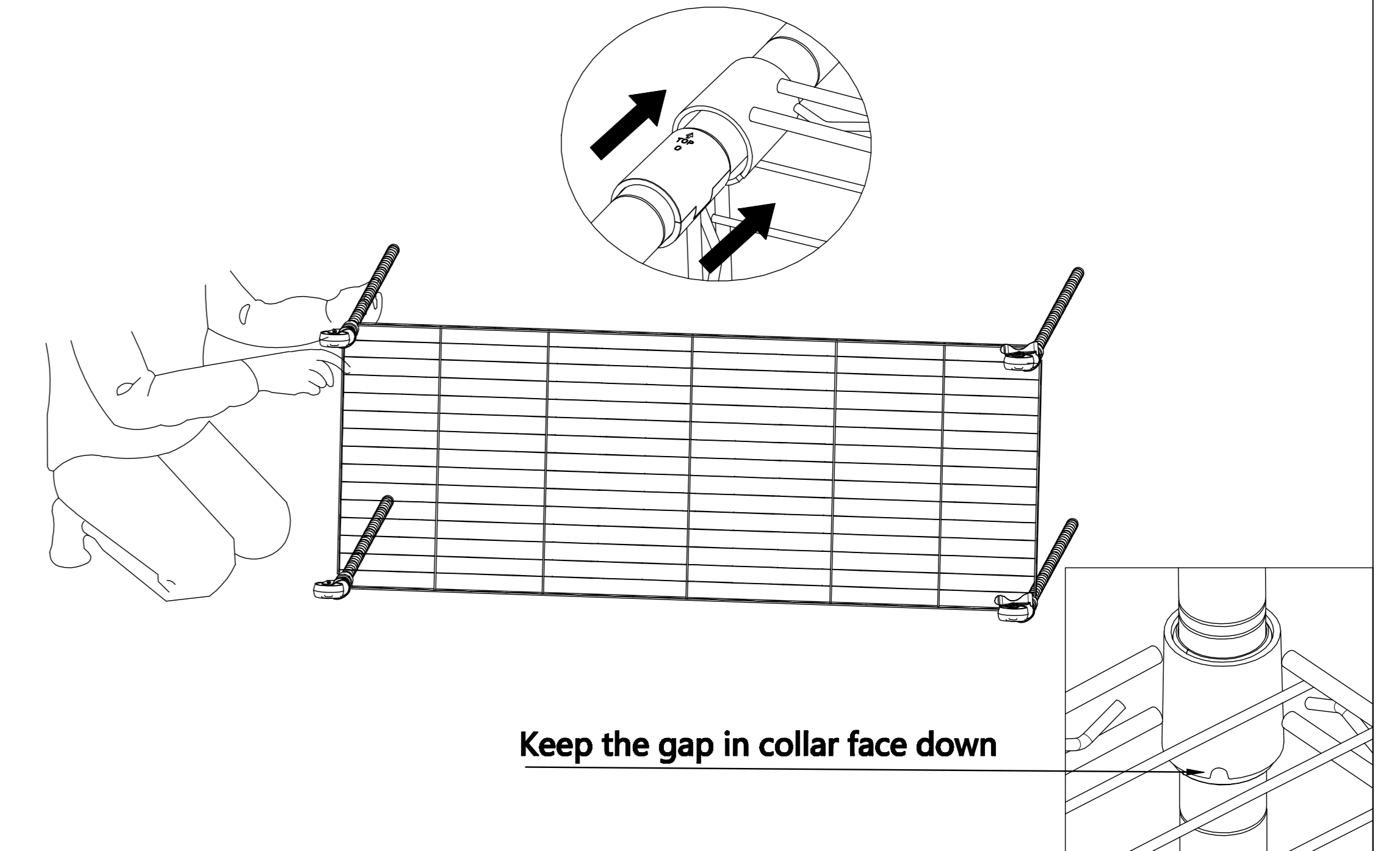

3 Refer to the Step 1 to snap the plastic clips on the grooves of four pieces of lower poles at your desired position and slide down the second wire shelf from the top of each lower pole down onto the plastic clips.

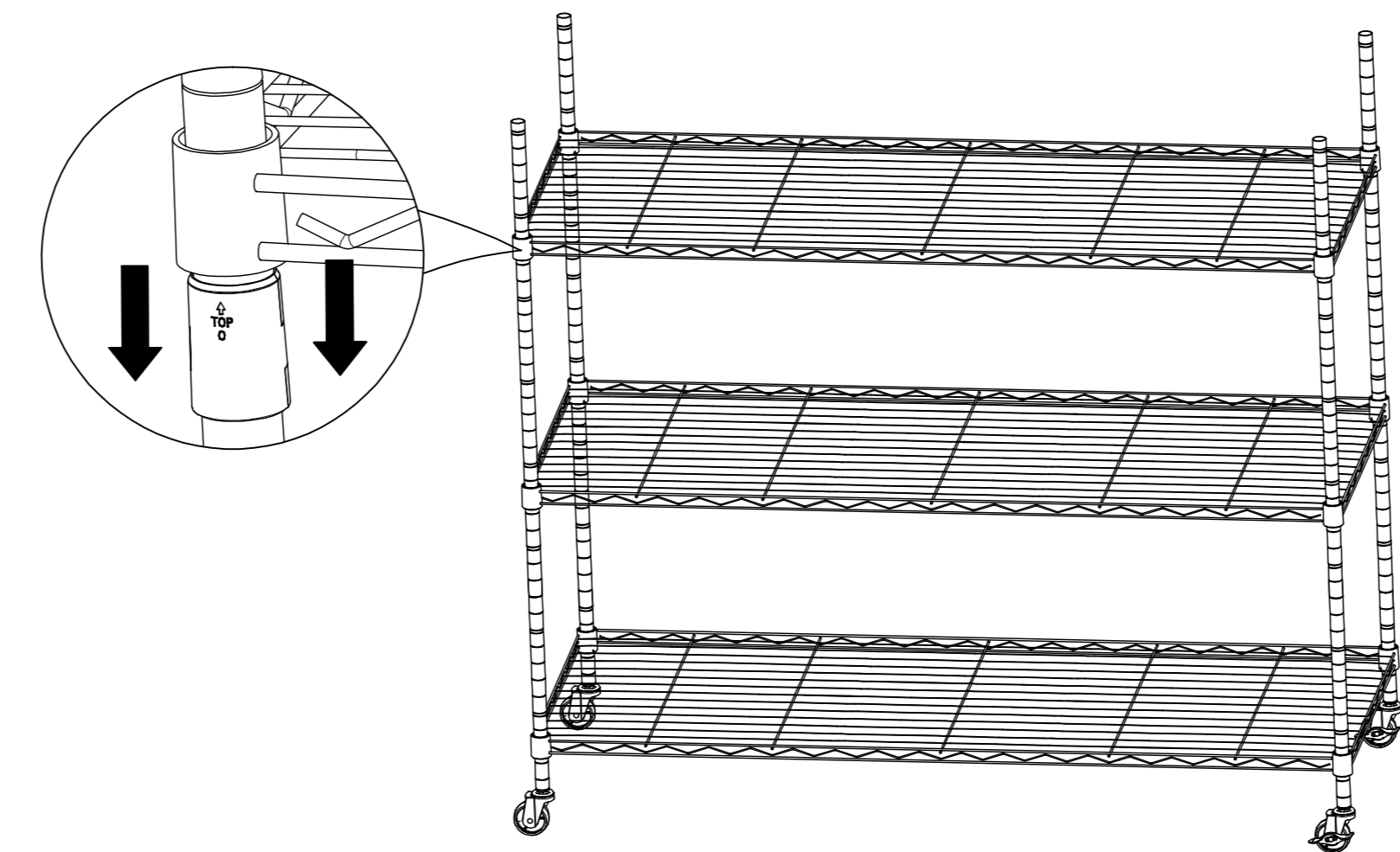

4 Screw the other 4 Poles into lower poles by Screw connectors(D).

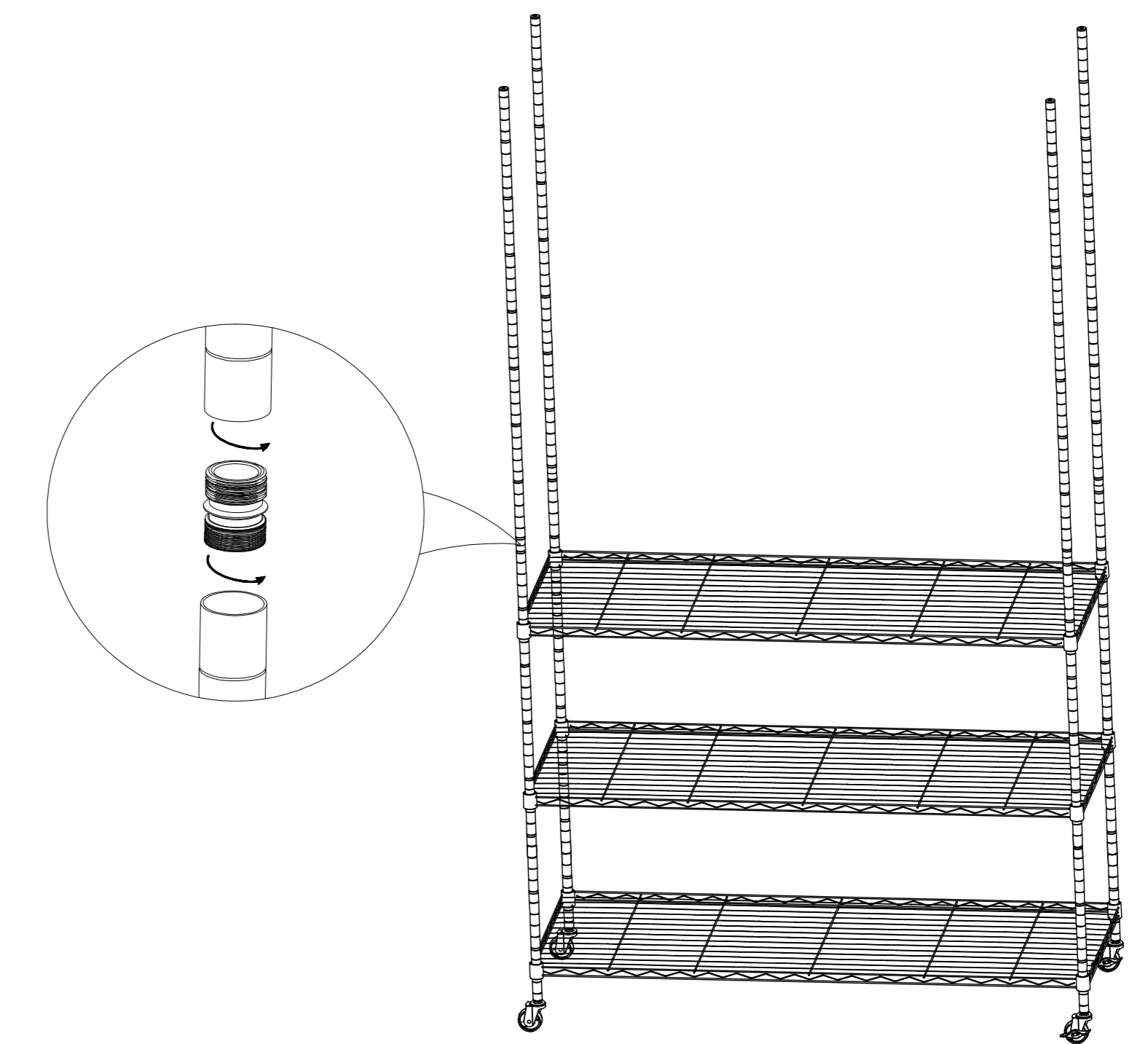

5 Refer to the above step(3) to snap the plastic clips on the same grooves of each pole at your desired position to assemble the other three pieces of wire sheves and Support Rail With Hooks (B) .

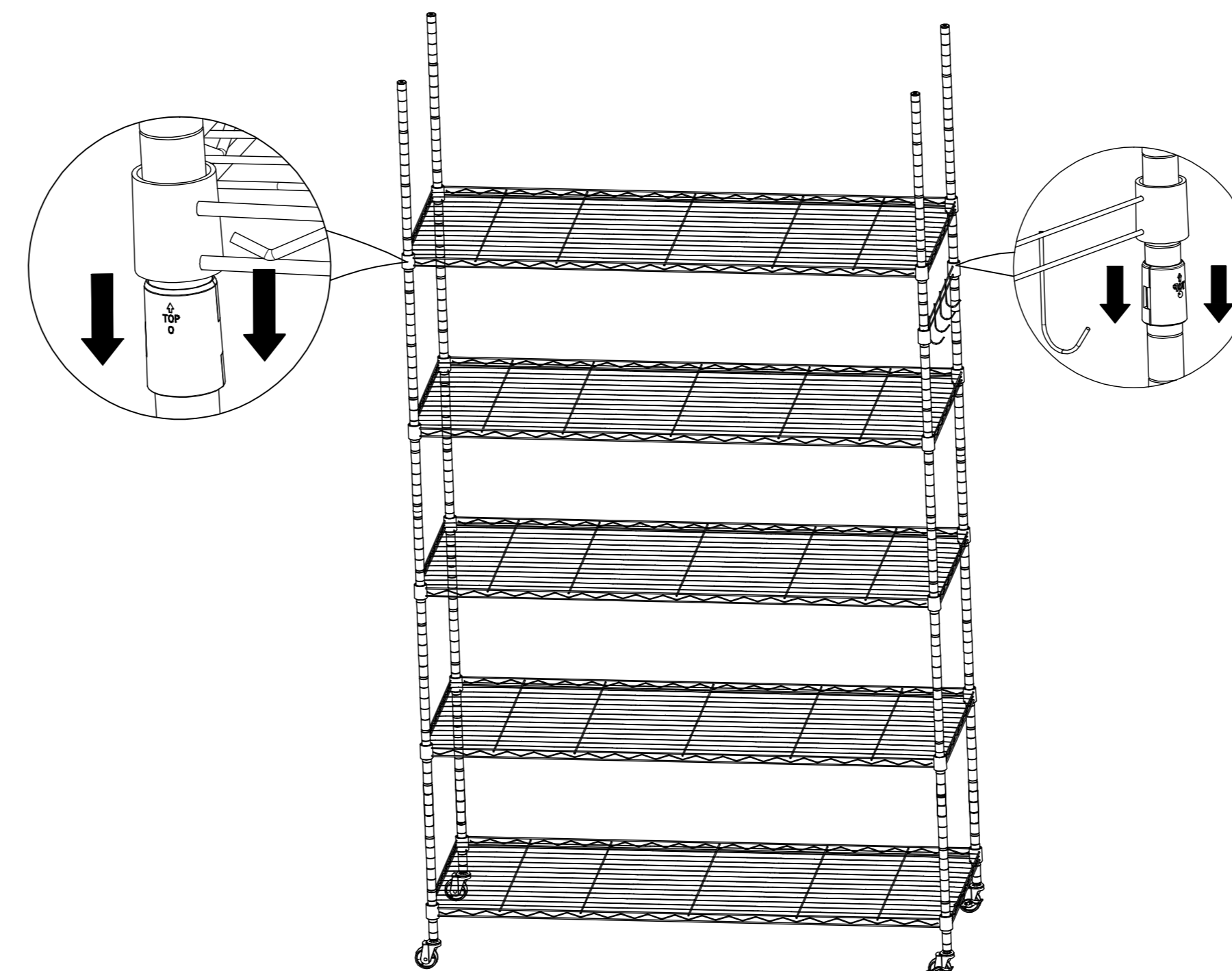

6 Pushing firmly down on every wire shelf at its corners by rubber mallet to ensure all the shelves in a place over the plastic clips. And screw leveling feet in or out to attain proper leveling.

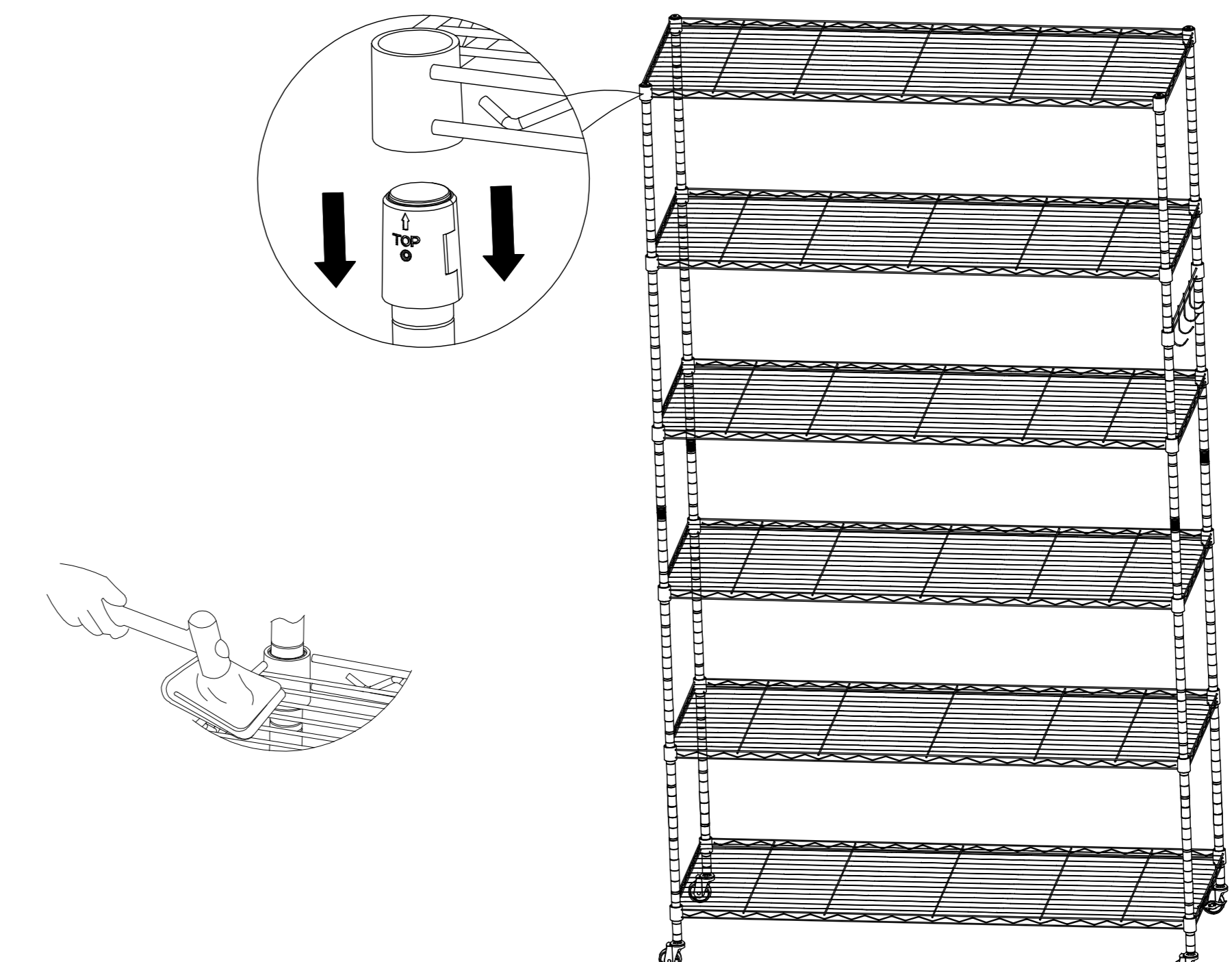

No.	A	B	C	D	E	F	G	H
Name	Wire Shelf	Support Rail with Hooks	Poles	Screw Connector	Plastic Clips	Casters	Leveling Foot	Plastic Cap
Parts								
Quantity	6PCS	1PC	8PCS	4PCS	52PCS	4PCS	4PCS	8PCS