

ASSEMBLY INSTRUCTION

Thank you for purchasing this quality product. Be sure to check all packing material carefully for small parts which may have come loose inside the carton during shipment. Separate, identify and count all parts and hardware. Compare with the parts list to be sure all parts are present.

IMPORTANT : PLEASE READ INSTRUCTION BEFORE STARTING THE ASSEMBLY.

"DO NOT TIGHTEN SCREWS UNTIL COMPLETELY ASSEMBLED"

"DO NOT OVERTIGHT ANY HARDWARE"

WARNING : SMALL PARTS AND HARDWARE NOT FOR CHILDREN UNDER 3 YEARS. ADULT ASSEMBLY REQUIRED.

****WARNING :** This product got power cable at the backside of (1). please make sure it will not be damage during every steps.

TABLE OF CONTENTS

HARDWARES LIST	PAGE 2 - 3
PARTS LIST	PAGE 4
PARTS' LOCATION	PAGE 5
DESCRIPTION	PAGE 6
ASSEMBLY STEPS	PAGE 7 - 9
ASSEMBLY COMPLETED	PAGE 10

ASSEMBLY TOOLS REQUIRED



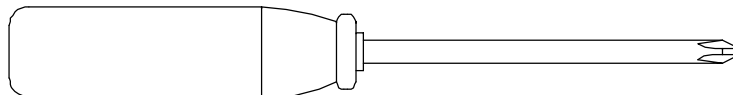

1. Screwdriver (not provide)

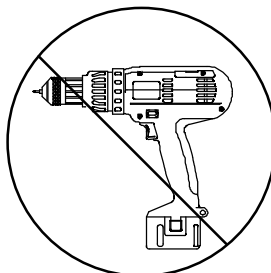

Skip the power trip this time.

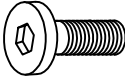
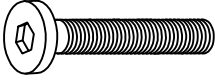
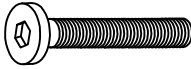

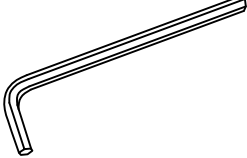

HARDWARES LIST

ITEM	DESCRIPTION	DRAWING	QTY
A	JCBC SCREW M8 x 16MM		16 PCS
B	JCBC SCREW M8 x 40MM		6 PCS
C	JCBC SCREW M6 x 35MM		4 PCS
D	SPRING WASHER M8 x 14MM		14 PCS
E	FLAT WASHER M8 x 22MM		14 PCS
F	CSK C/B SCREW (M4 x 32MM)		8 PCS
G	M4 ALLEN KEY (65MM)		1 PC
H	M5 ALLEN KEY (65MM)		1 PC

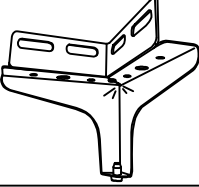
HARDWARES LIST

ITEM	DESCRIPTION	DRAWING	QTY
I	PLUG WITH CONNECTOR WIRE	 A technical drawing of a rectangular plug with a connector wire. The wire is shown as a single line that loops and then ends in a small, dark connector tip.	1 PC
J	FOOTBOARD METAL SUPPORT LEG	 A technical drawing of a metal support leg. It features a wide, flat top surface with several small rectangular cutouts. The top surface is supported by a vertical stem that tapers slightly towards the bottom, where it ends in a small, rounded foot.	2 PCS

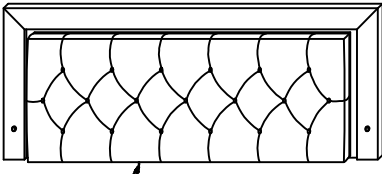
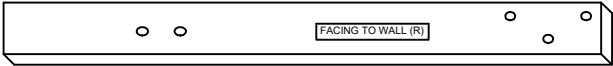
PARTS LIST

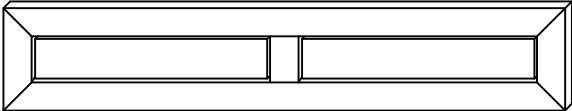
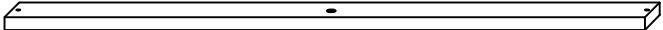
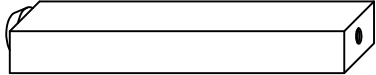
ITEM	DESCRIPTION	DRAWING	QTY
1	HEADBOARD		1 PC
2	HEADBOARD SUPPORT LEG - WITH "FACING TO WALL (R)" STICKER		1 PC
3	HEADBOARD SUPPORT LEG - WITH "FACING TO WALL (L)" STICKER		1 PC
4	FOOTBOARD		1 PC
7	SLAT		4 PCS
8	CENTRE SUPPORT LEG		4 PCS

PARTS LIST (BOX 2)

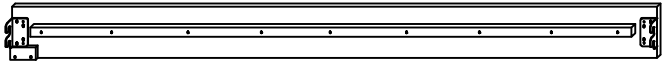
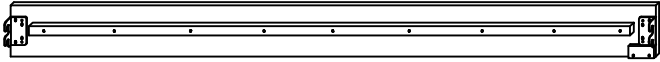
ITEM	DESCRIPTION	DRAWING	QTY
5	SIDE RAIL (i)		1 PC
6	SIDE RAIL (ii)		1 PC

PARTS ' LOCATION

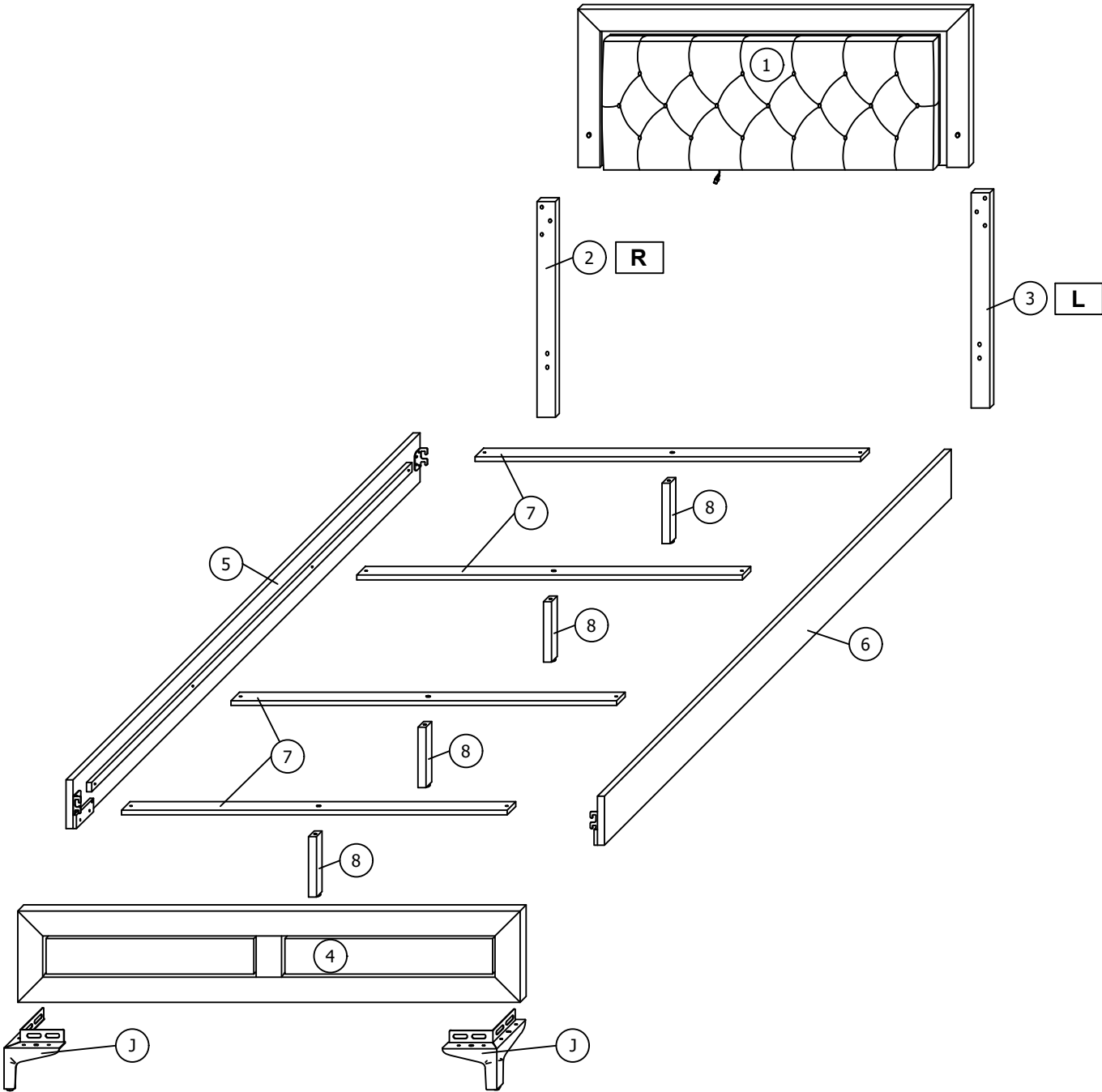

DESCRIPTION

There are two stickers pre-sticked on backside of (1) which separately marked with L and R .

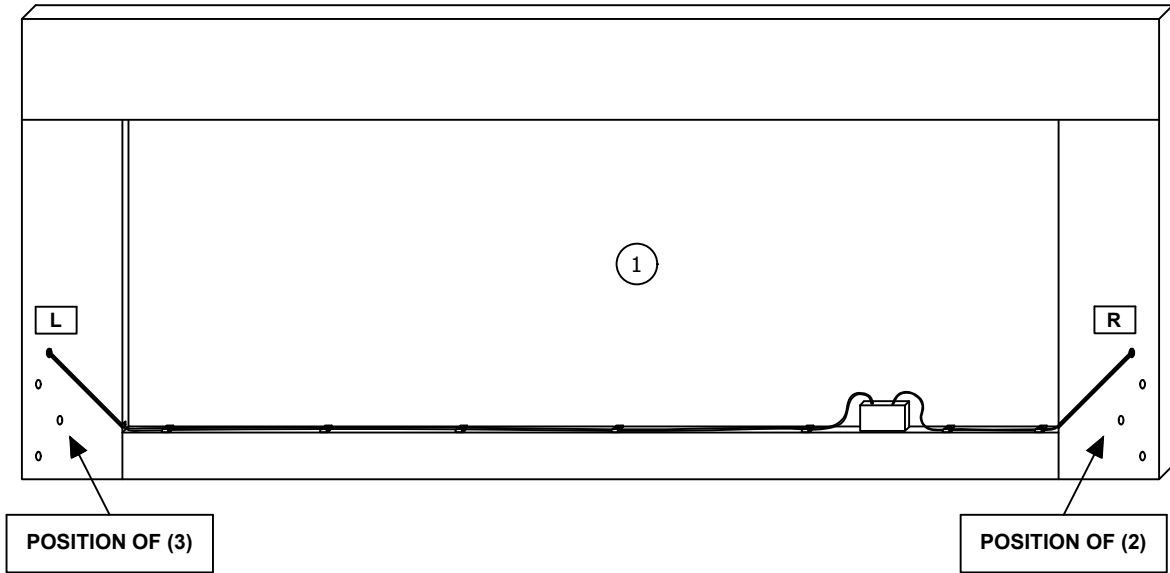

One side of (2),(3) label the sticker facing to outside during assembly.

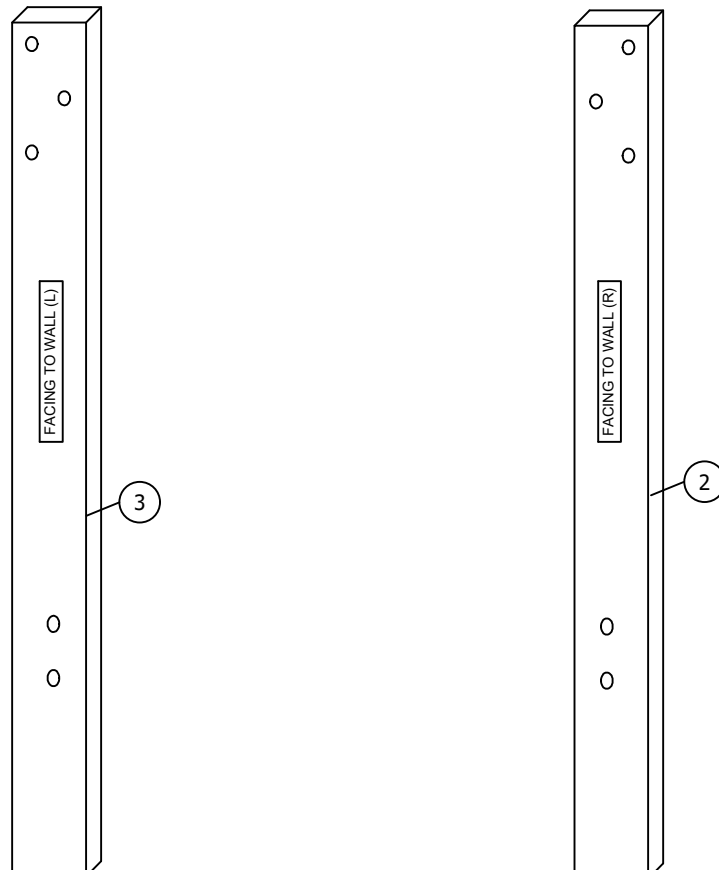

ASSEMBLY STEPS

STEP 1

Insert 1 piece (C) to combine 1 piece (7),(8) as shown. This step needs to be **done four times**.

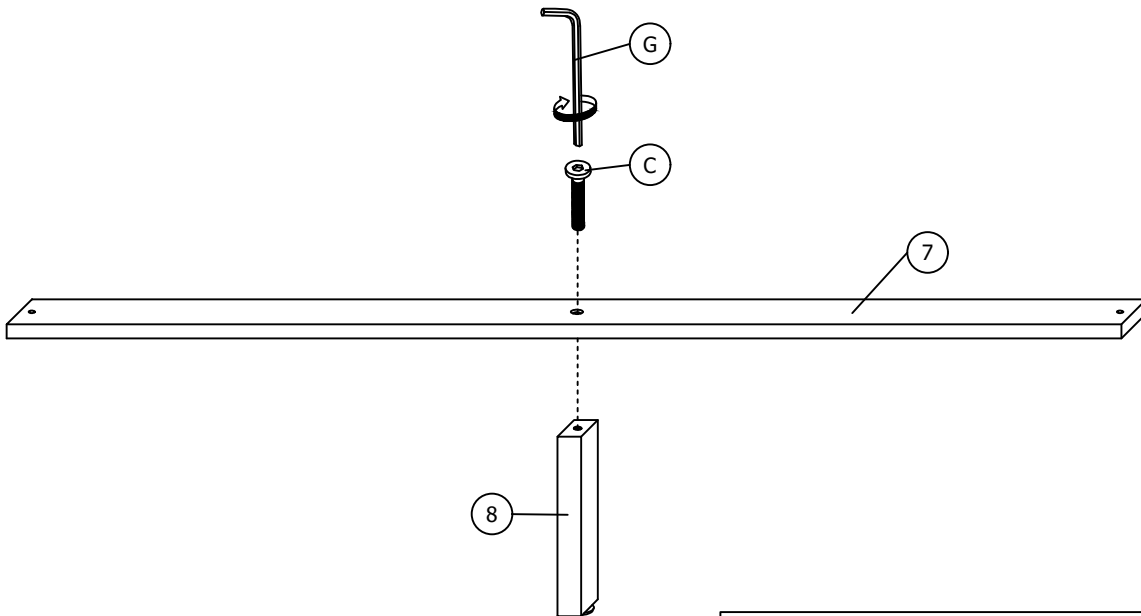

Assembled looks

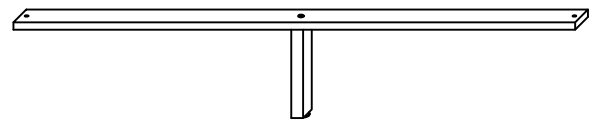

STEP 2

Insert 6 pieces (B),(D) and (E) to combine (2) and (3) to the (1) as shown.

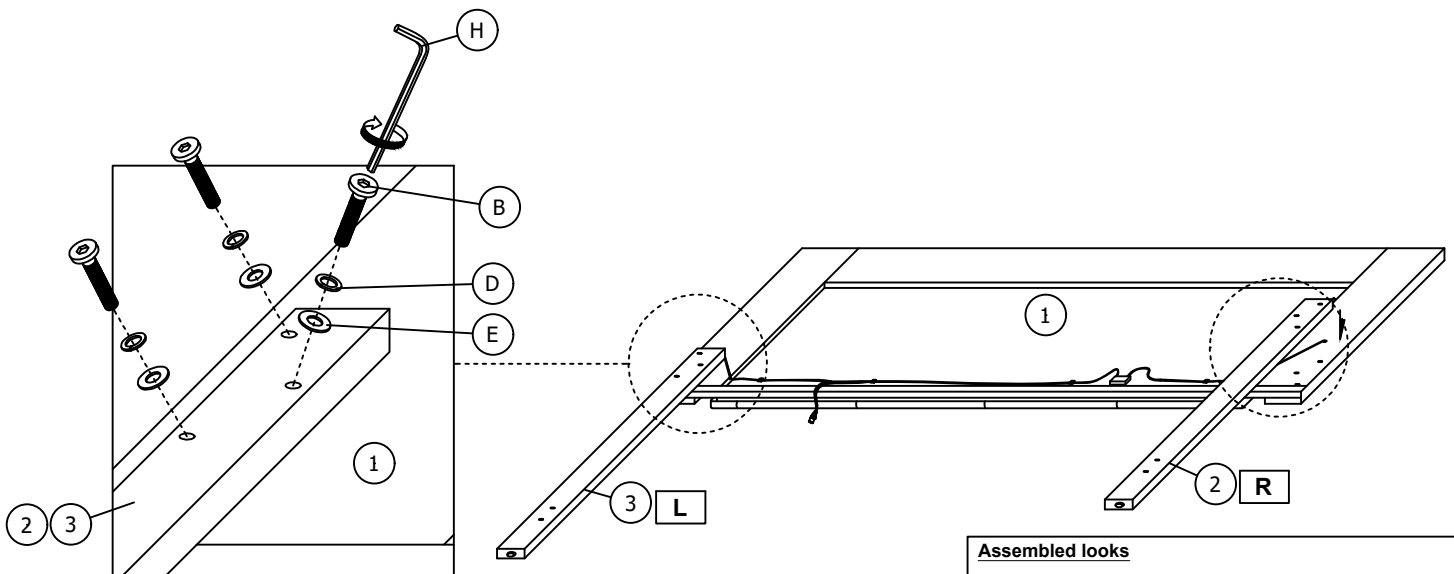

Assembled looks

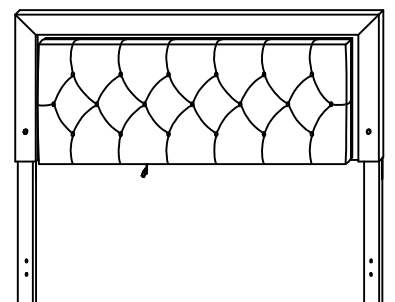

STEP 3

Insert all the 8 pieces (A) to combine (2),(3),(4),(5),(6). Then insert 8 pieces (A),(D) and (E) to combine (J) to (4),(5),(6) as shown.

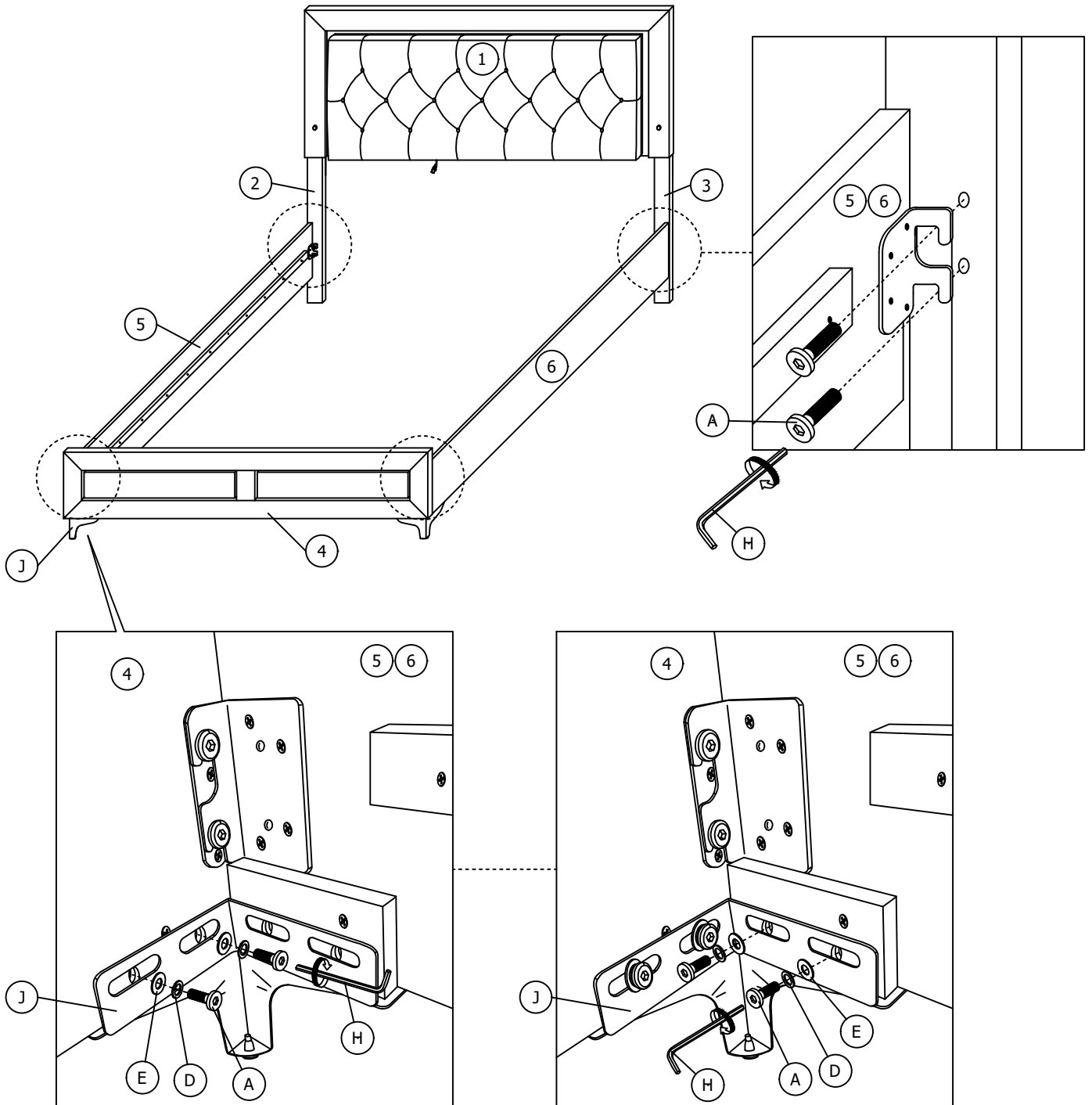

STEP 4

Insert all the 8 pieces (F) to fix the (7) on the wood of (5),(6) as shown.

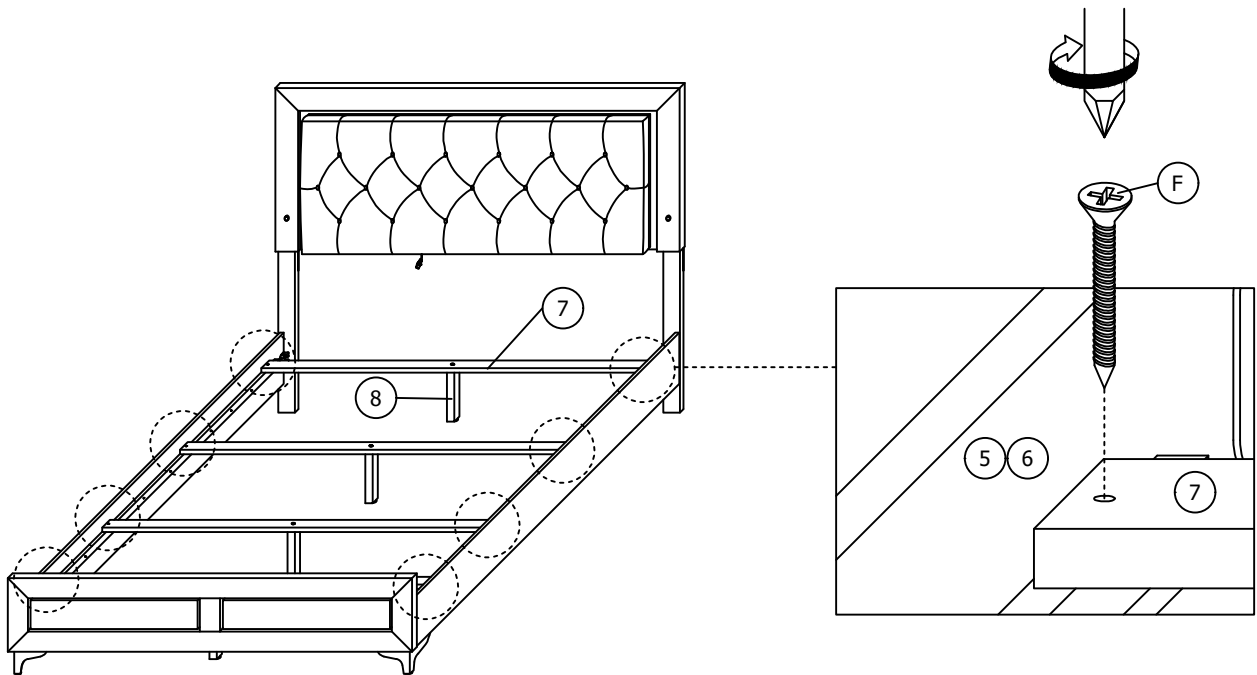

STEP 5

Combine the connector wire (I) to the power cable , then plug in the plug head (I) to the power outlet as shown.

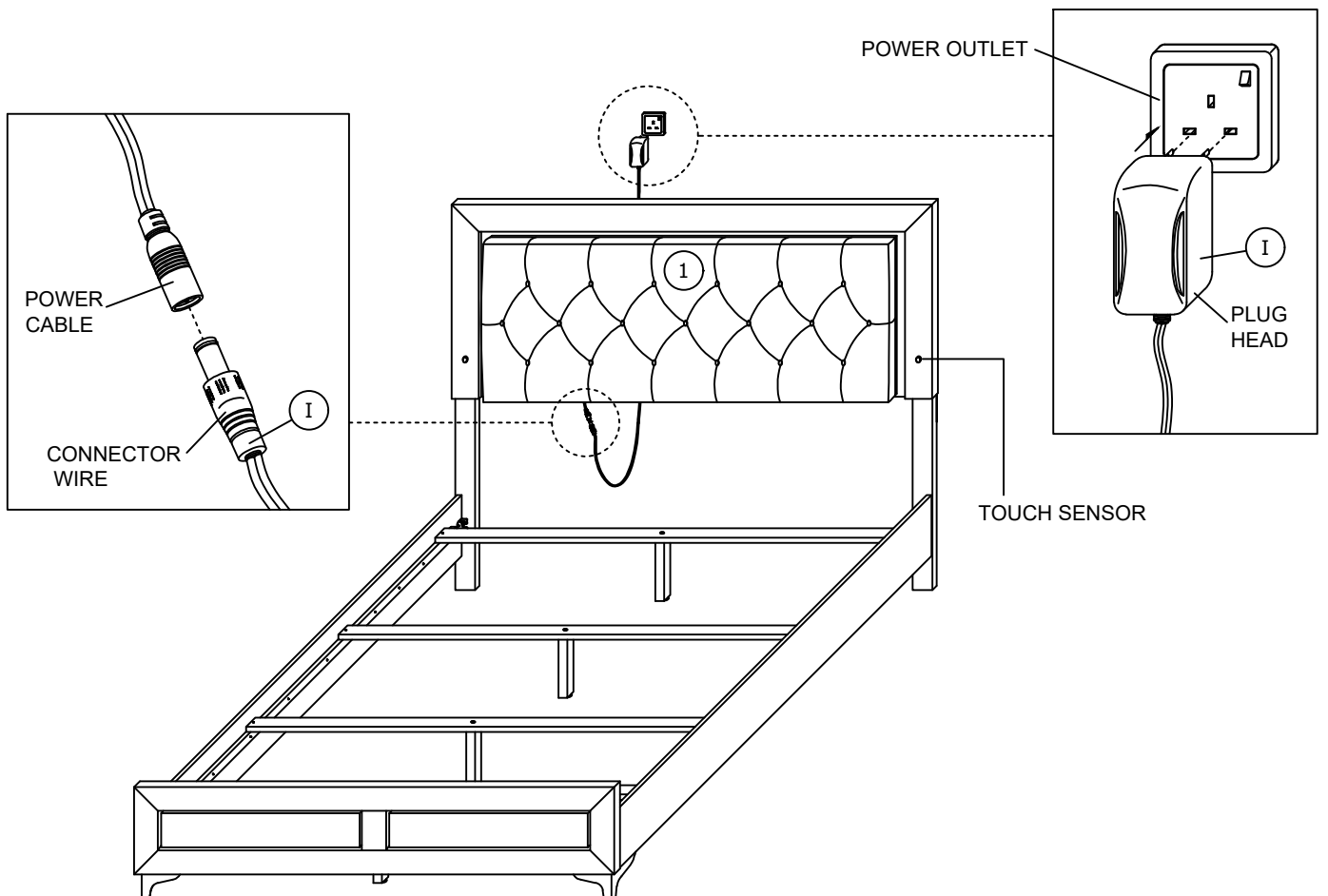

STEP 6

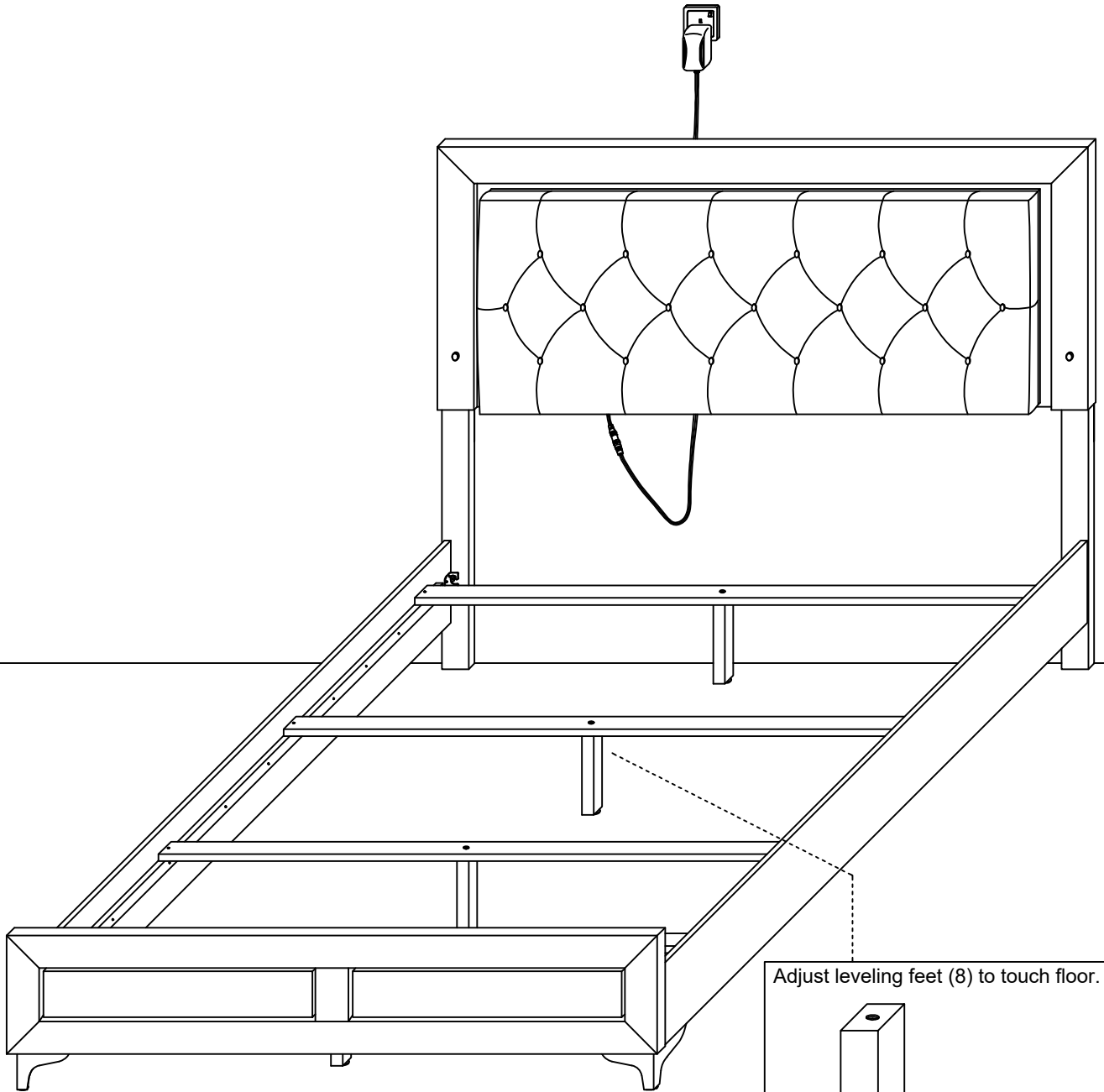

Adjust leveling feet (8) to touch floor.

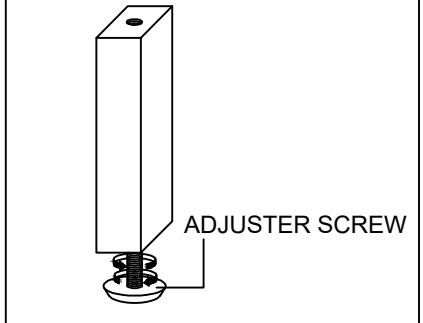

ASSEMBLY COMPLETED

** FOR ALL MODEL AND ALL SIZE BED

