

CITY USA WITHOUT APRON

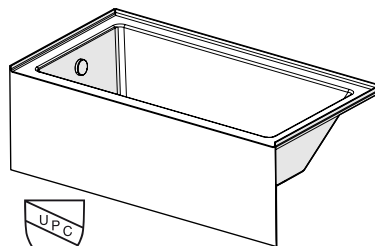

CITY USA WITH APRON

noken
PORCELANOSA Grupo

Ctra. Villarreal-Puebla de Arenoso (CV-20) km. 2
P.O./box 372 - 12540 Villarreal (Castellón) Spain

Tel: +34 964 50 64 50 _ Fax: +34 964 50 67 92 _ www.noken.com _ noken@noken.com

CITY USA



Noken Design baths are manufactured to the strictest standards to ensure quality performance and full customer satisfaction at all times. Each and every one of our baths is assembled and tested before leaving the factory.

All plumbing installation work should be effected in compliance with national regulations concerning plumbing installations in buildings.

The system must only be installed by qualified professionals.

Noken Design S.A. declines all responsibility in the event of improper installation.

The maximum recommended water hardness for the range of baths is 18°TH (French degree of hardness) / 13°e (English degree of hardness).

The baths are not designed to be used for seaweed, mud or seawater treatments, etc.

There is an increased risk of falls when the surface of most baths is wet and therefore slippery. This is particularly true when soap, shampoo, bath oils and other similar products are used. Users of baths must be aware of this fact.

NB: Before proceeding with the installation, check that all the parts supplied are in perfect condition. Notify the carrier immediately if this is not the case.

Les baignoires Noken Design sont fabriquées selon des critères de qualité très exigeants afin de garantir la satisfaction de l'utilisateur final.

Les baignoires sont montées et testées une par une dans nos installations, et soumises à de rigoureux contrôles techniques et de sécurité, pour nous assurer qu'elles fonctionnent correctement avant d'abandonner l'usine.

Les travaux de plomberie doivent être effectués conformément aux réglementations en vigueur dans chaque pays pour les installations de plomberie dans les bâtiments.

L'installation ne peut être réalisée que par un installateur qualifié uniquement.

Noken Design S.A. décline toute responsabilité en cas d'installation incorrecte.

La dureté maximale recommandée de l'eau pour la gamme de baignoires est de 18°TH (Degrés français) / 13°e (Degrés anglais).

Les baignoires n'ont pas été conçues pour les traitements aux algues, aux boues, aux eaux marines, etc.

Lorsqu'elle est humide, la surface de la plupart des baignoires présente un risque potentiel accru de dérapage. Ce risque est plus important en cas d'utilisation de savons, de shampoings, d'huiles pour le bain et d'autres produits similaires. Il est très important que les utilisateurs des baignoires en soient conscients.

Remarque: S'assurer que les pièces de la baignoire sont en parfait état avant de procéder à son installation. Si ce n'est pas le cas, adresser une réclamation au transporteur.

Las bañeras Noken Design han sido fabricadas con elevadas exigencias y pensando, en todo momento, en la satisfacción del usuario final.

Las bañeras son montadas y puestas a prueba, una a una, superando rigurosos controles técnicos y de seguridad, en nuestras instalaciones, para verificar su correcto funcionamiento, antes de salir de fábrica.

La instalación de fontanería debe hacerse de acuerdo con la reglamentación vigente en cada país para las instalaciones de fontanería en edificios.

La instalación debe ser realizada exclusivamente por un instalador cualificado.

Asimismo Noken Design S.A. declina toda responsabilidad en caso de una instalación incorrecta.

La máxima dureza del agua aconsejable para esta gama de bañeras es de 18°TH (Grados franceses) / 13°e (Grados ingleses).

Las bañeras no han sido diseñadas para tratamientos con algas, barro, aguas marinas, etc.

Cuando está húmeda, la superficie de la mayor parte de las bañeras presenta un aumento del riesgo potencial de deslizamiento. Esto es más significativo cuando se utiliza jabón, champú, aceites para el baño y otros productos similares. Es importante que los usuarios de las bañeras sean conscientes de esto.

Nota: Verificar, antes de realizar la instalación, el perfecto estado de las piezas. En caso contrario, reclamar al transportista.



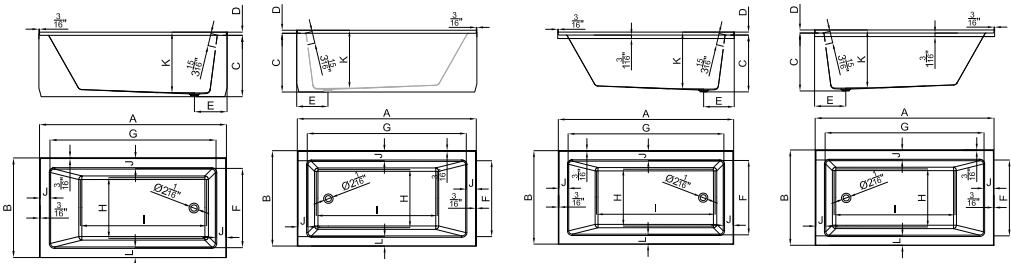

100160234_N710001174
100160235_N710001172
100160307_N710001164

100160300_N710001165
100160292_N710001173
100160306_N710001167

100160279_N710001170
100160301_N710001171
100160305_N710001168

100160278_N710001166
100160291_N710001169
100160293_N710001175

DIMENSIONS	POSITION	APPRON	SAP	KEA	A	B	C	D	E	F	G	H	I	J	K	L
60" X 32"	left	integrated	100160234	N710001174	60"	31" 15/16	19" 11/16	1"	10" 1/2	25" 1/2	53" 5/16	19" 7/16	40" 9/16	3" 3/8	19" 11/16	3" 1/8
	izquierda	without	100160279	N710001170	60"	31" 15/16	19" 7/16	1"	10" 1/2	25" 1/2	53" 5/16	19" 7/16	40" 9/16	3" 3/8	19" 11/16	3" 1/8
	right	integrated	100160300	N710001165	60"	31" 15/16	19" 11/16	1"	10" 1/2	25" 1/2	53" 5/16	19" 7/16	40" 9/16	3" 3/8	19" 11/16	3" 1/8
	derecha	without	100160278	N710001166	60"	31" 15/16	19" 7/16	1"	10" 1/2	25" 1/2	53" 5/16	19" 7/16	40" 9/16	3" 3/8	19" 11/16	3" 1/8
66" X 32"	left	integrated	100160235	N710001172	66"	31" 15/16	19" 11/16	1"	10" 1/2	25" 1/2	56" 5/16	19" 7/16	46" 9/16	3" 3/8	19" 11/16	3" 1/8
	izquierda	without	100160301	N710001171	66"	31" 15/16	19" 7/16	1"	10" 1/2	25" 1/2	56" 5/16	19" 7/16	46" 9/16	3" 3/8	19" 11/16	3" 1/8
	right	integrated	100160292	N710001173	66"	31" 15/16	19" 11/16	1"	10" 1/2	25" 1/2	56" 5/16	19" 7/16	46" 9/16	3" 3/8	19" 11/16	3" 1/8
	derecha	without	100160291	N710001169	66"	31" 15/16	19" 7/16	1"	10" 1/2	25" 1/2	56" 5/16	19" 7/16	46" 9/16	3" 3/8	19" 11/16	3" 1/8
72" X 32"	left	integrated	100160307	N710001164	71 15/16"	31" 15/16	19" 11/16	1"	10" 1/2	25" 1/2	65" 1/4	19" 7/16	52" 1/2	3" 3/8	19" 11/16	3" 1/8
	izquierda	without	100160305	N710001168	71 15/16"	31" 15/16	19" 7/16	1"	10" 1/2	25" 1/2	65" 1/4	19" 7/16	52" 1/2	3" 3/8	19" 11/16	3" 1/8
	right	integrated	100160306	N710001167	71 15/16"	31" 15/16	19" 11/16	1"	10" 1/2	25" 1/2	65" 1/4	19" 7/16	52" 1/2	3" 3/8	19" 11/16	3" 1/8
	derecha	without	100160293	N710001175	71 15/16"	31" 15/16	19" 7/16	1"	10" 1/2	25" 1/2	65" 1/4	19" 7/16	52" 1/2	3" 3/8	19" 11/16	3" 1/8

DIMENSIONS	POSITION	APPRON	SAP	KEA	A	B	C	D	E	F	G	H	I	J	K	L
60" X 32"	left	integrated	100160234	N710001174	1524	812	500	26	266	647	1354	494	1030	85	500	80
	izquierda	without	100160279	N710001170	1524	812	494	26	266	647	1354	494	1030	85	500	80
	right	integrated	100160300	N710001165	1524	812	500	26	266	647	1354	494	1030	85	500	80
	derecha	without	100160278	N710001166	1524	812	494	26	266	647	1354	494	1030	85	500	80
66" X 32"	left	integrated	100160235	N710001172	1676	812	500	26	266	647	1506	494	1182	85	500	80
	izquierda	without	100160301	N710001171	1676	812	494	26	266	647	1506	494	1182	85	500	80
	right	integrated	100160292	N710001173	1676	812	500	26	266	647	1506	494	1182	85	500	80
	derecha	without	100160291	N710001169	1676	812	494	26	266	647	1506	494	1182	85	500	80
72" X 32"	left	integrated	100160307	N710001164	1828	812	500	26	266	647	1658	494	1334	85	500	80
	izquierda	without	100160305	N710001168	1828	812	494	26	266	647	1658	494	1334	85	500	80
	right	integrated	100160306	N710001167	1828	812	500	26	266	647	1658	494	1334	85	500	80
	derecha	without	100160293	N710001175	1828	812	494	26	266	647	1658	494	1334	85	500	80

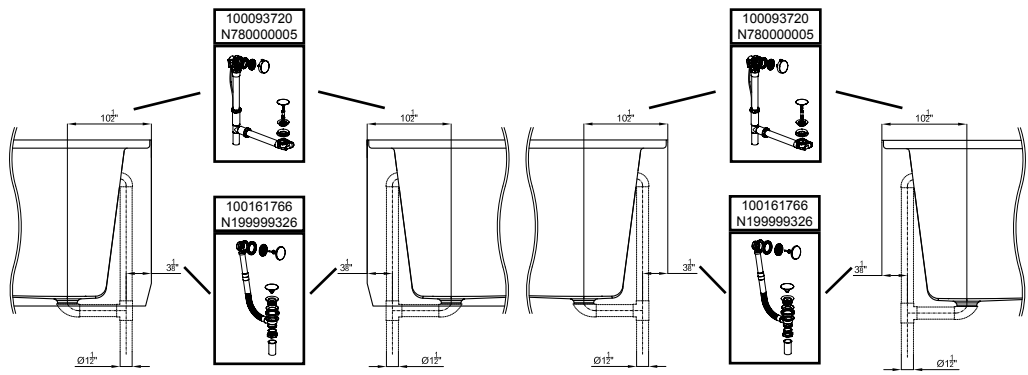

100160234_N710001174
100160235_N710001172
100160307_N710001164

100160300_N710001165
100160292_N710001173
100160306_N710001167

100160279_N710001170
100160301_N710001171
100160305_N710001168

100160278_N710001166
100160291_N710001169
100160293_N710001175



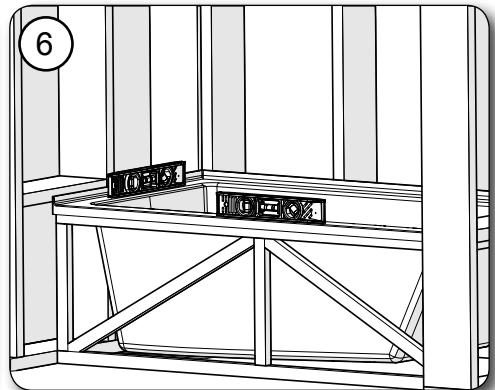
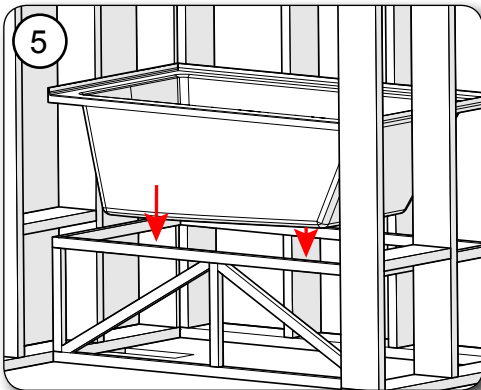
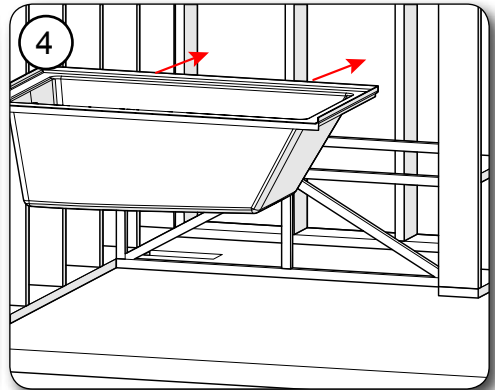
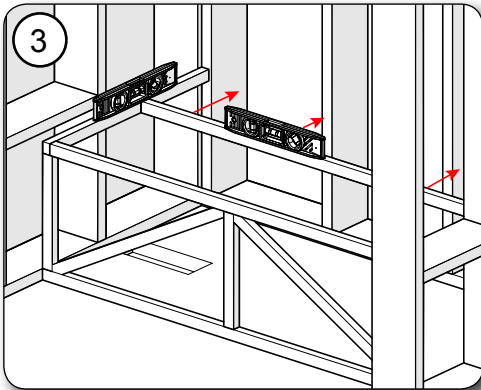
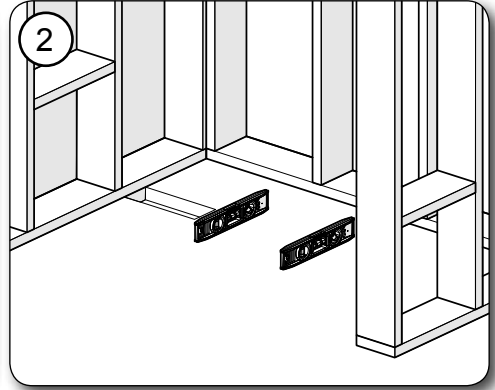
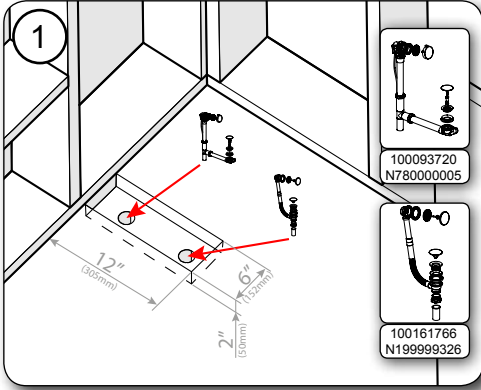



A

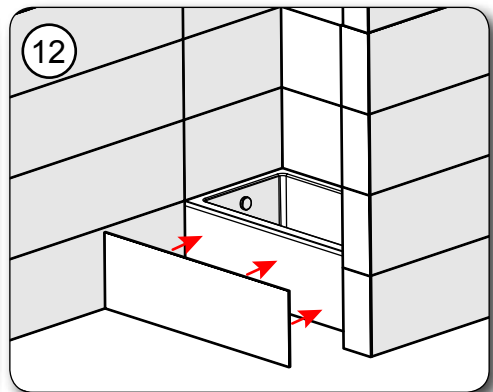
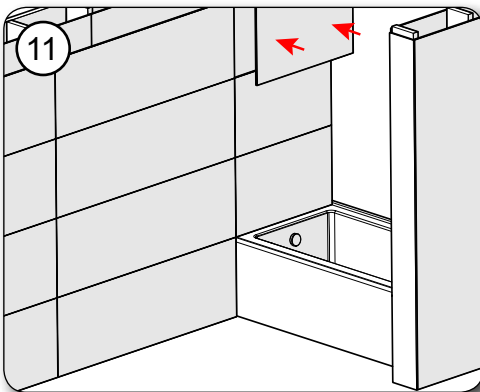
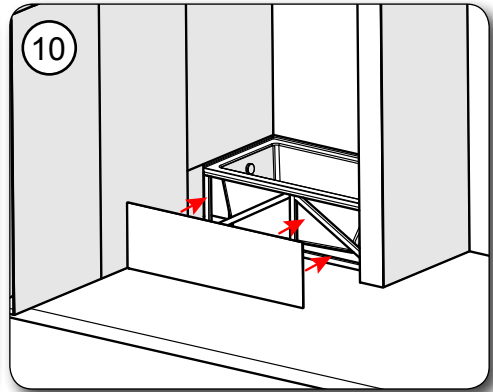
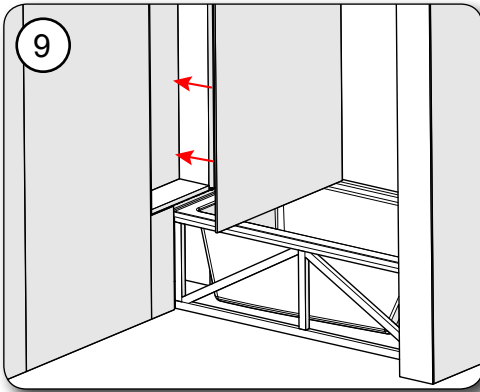
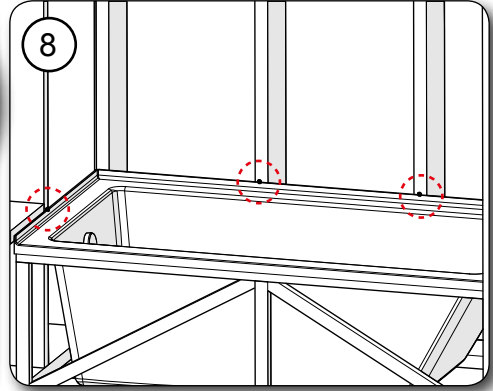
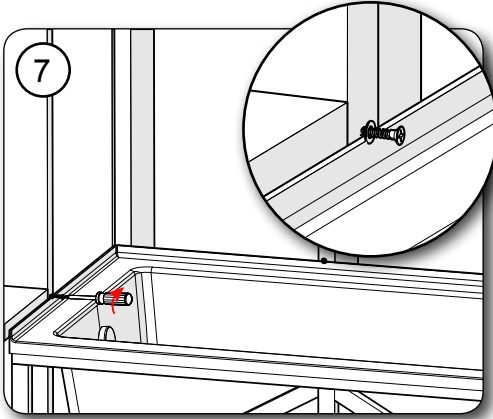

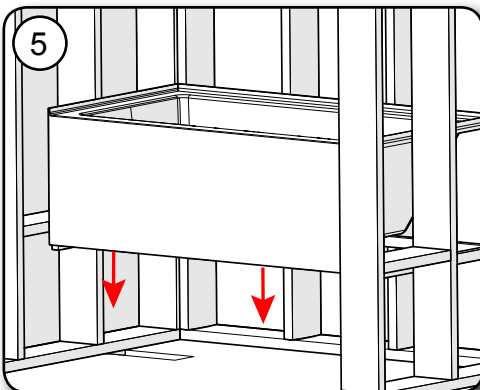
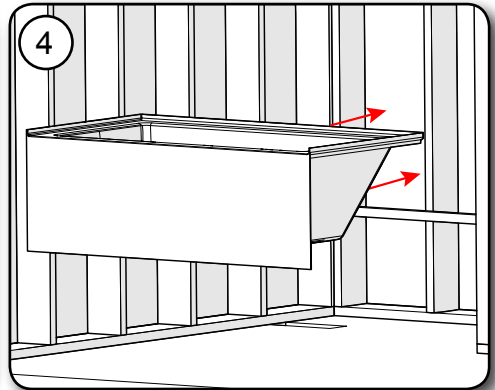
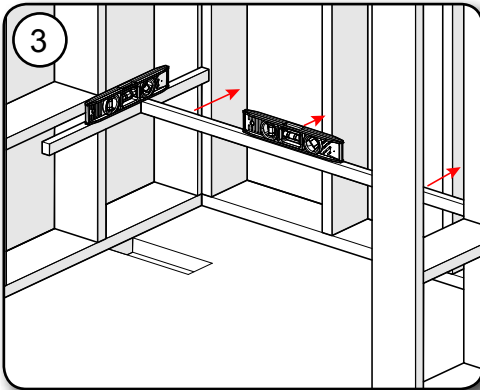
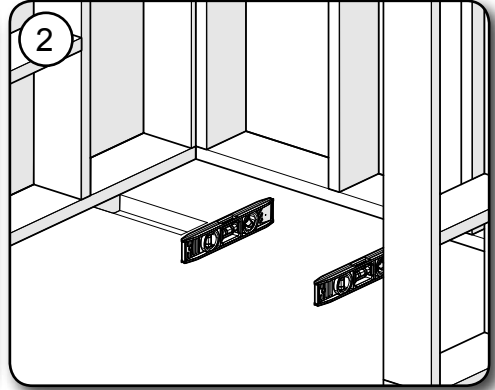
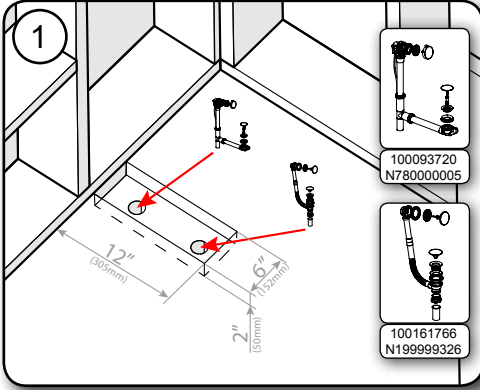



B

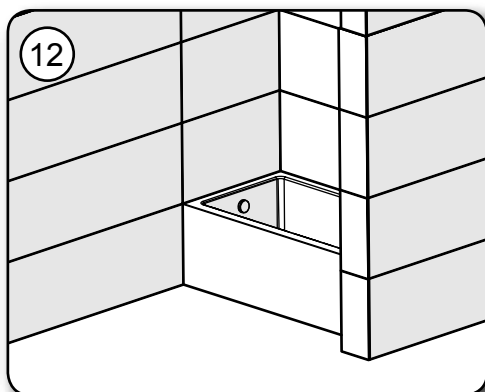
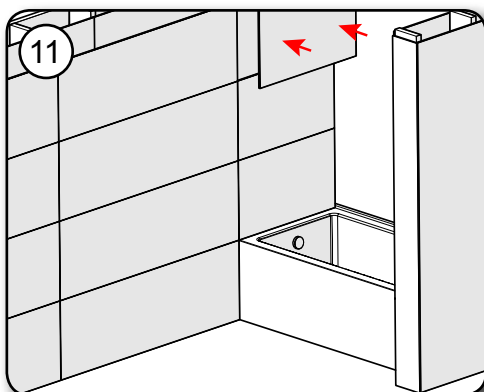
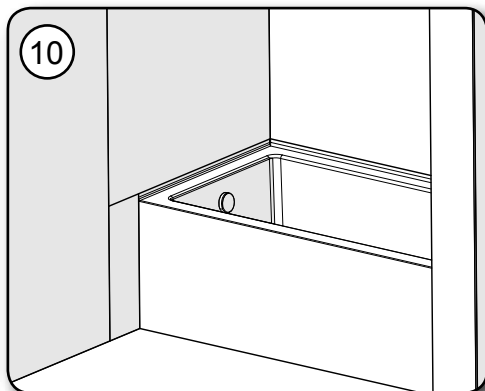
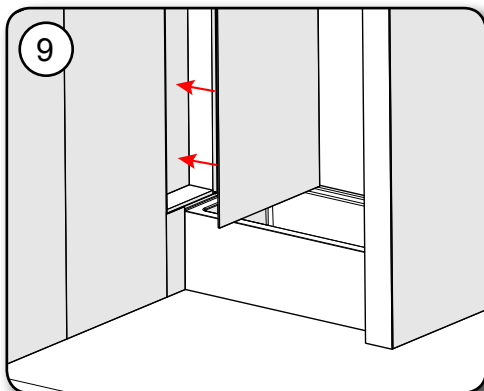
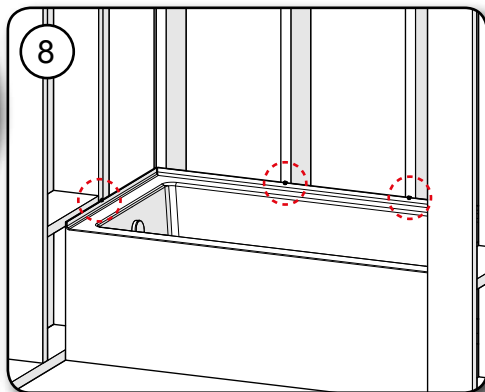
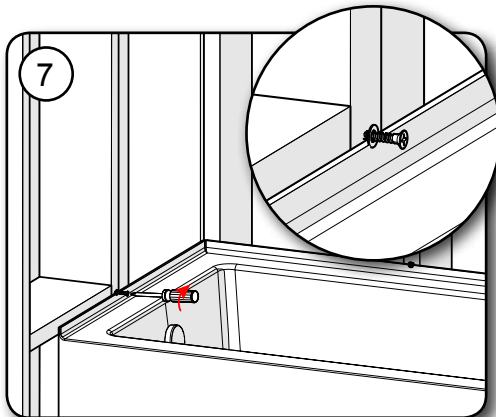



CITY	
60"	49 gal
66"	55 gal
72"	62 gal



Clean the bath with liquid soap and water and soft, non abrasive cloths or sponges.
Never clean with solvents (acetone, alcohol, etc), detergents, or abrasive cloths as these could damage its finish.
To keep the bath looking shiny, use a standard household polish.

CLEANING THE METAL PARTS

Use a soft cloth to clean any metal parts and leave them shiny and scratch free.

Pour le nettoyage de la baignoire, employer des savons liquides et de l'eau, et utiliser des éponges ou linges non abrasifs.

Pour nettoyer, n'utiliser en aucun cas des produits solvants (acétone, alcool, etc.), ni des détergents ou des linges abrasifs, ce qui endommagerait la surface de la baignoire.

Pour faire briller la baignoire, employer un produit de lustrage ordinaire du commerce.

NETTOYAGE DES ÉLÉMENTS MÉTALLIQUES

Pour nettoyer les éléments métalliques, utiliser un linge doux de manière à ne pas rayer les différentes finitions métalliques.

Para la limpieza de la bañera, utilizar jabones líquidos y agua con paños o esponjas no abrasivos.

Nunca utilizar productos disolventes (acetona, alcohol, etc), ni detergents o paños abrasivos que dañarían la superficie de la misma.

Para dar brillo a la bañera, utilizar un pulimento de los habituales en el mercado.

PARTES METÁLICAS

Para la limpieza de las partes metálicas, utilizar un paño suave para no rayar los distintos acabados metálicos.

