

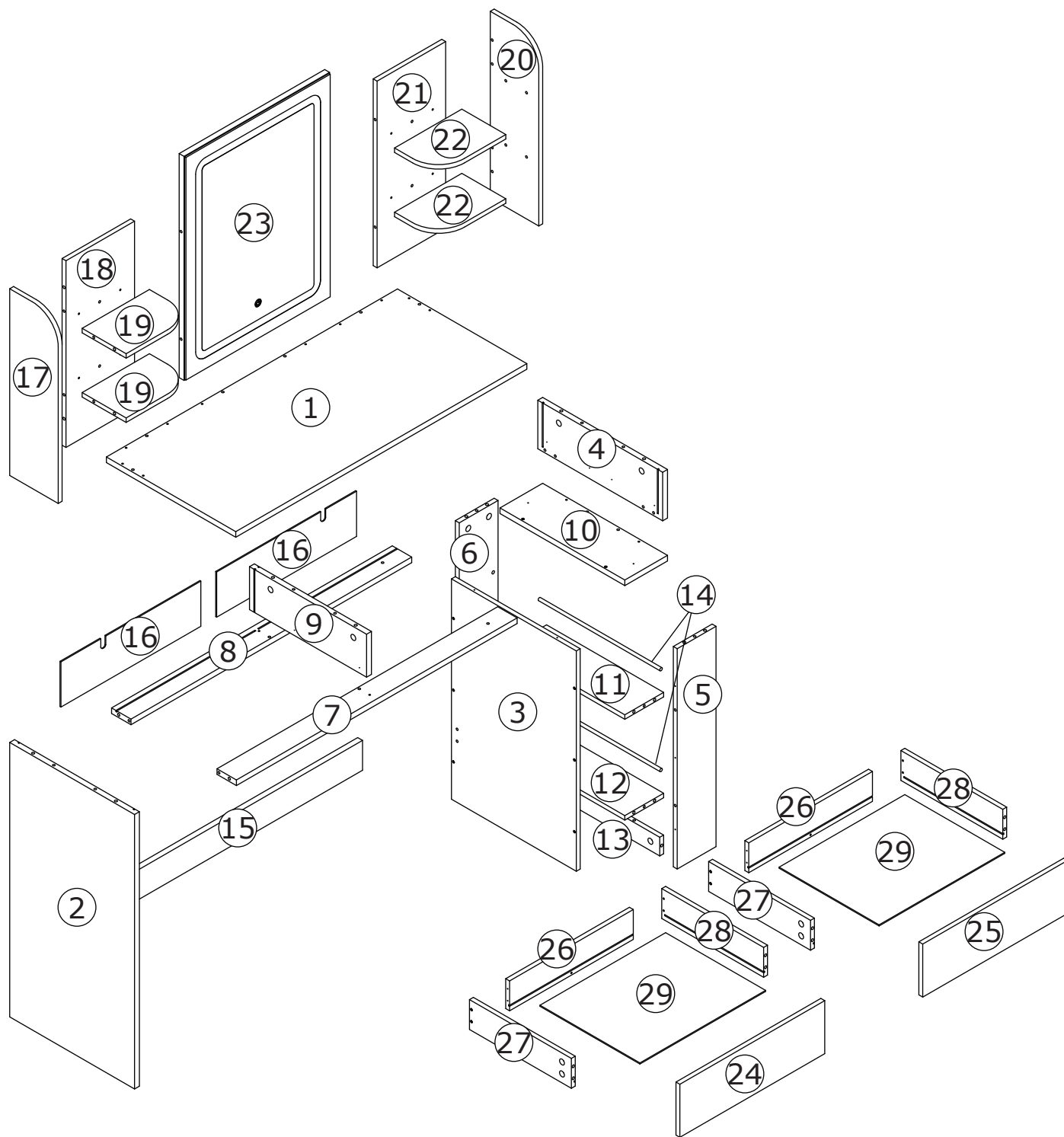

ASSEMBLY INSTRUCTIONS







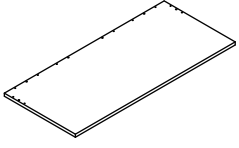
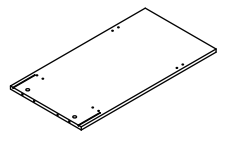
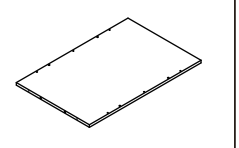
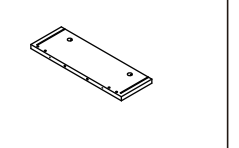
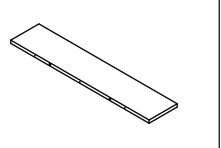
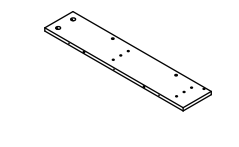
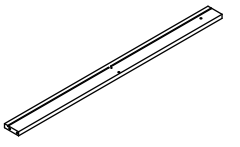
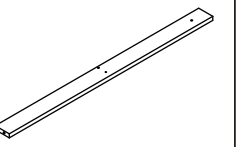
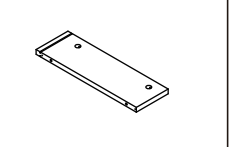
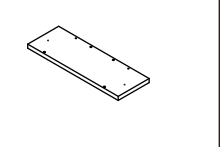
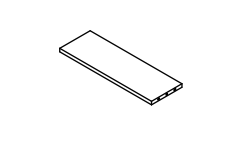
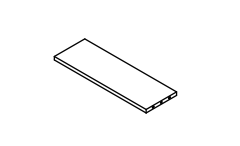
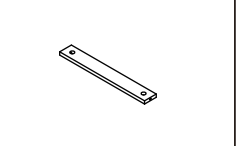
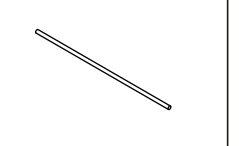
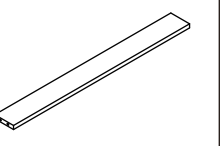
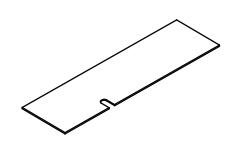
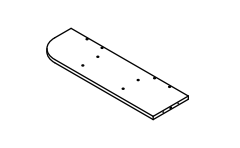
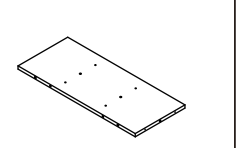
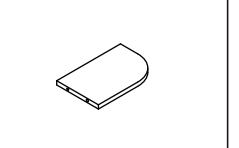
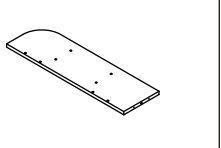
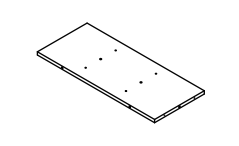
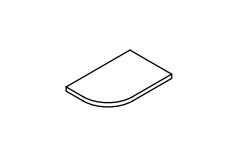
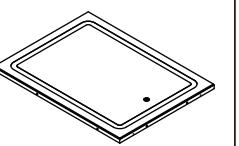
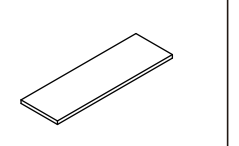
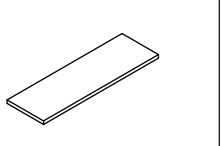
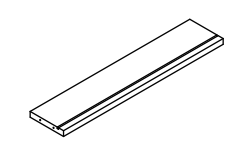
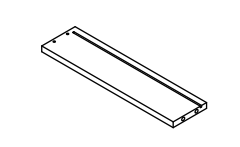
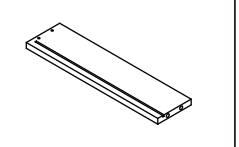
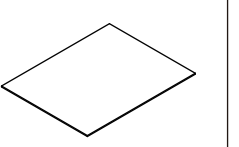



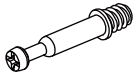



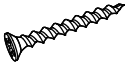

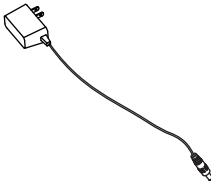
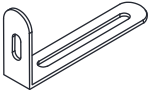

Parts and Operation Elements

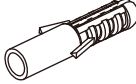
				
① 1pc	② 1pc	③ 1pc	④ 1pc	⑤ 1pc
				
⑥ 1pc	⑦ 1pc	⑧ 1pc	⑨ 1pc	⑩ 1pc
				
⑪ 1pc	⑫ 1pc	⑬ 1pc	⑭ 2pcs	⑮ 1pc
				
⑯ 2pcs	⑰ 1pc	⑱ 1pc	⑲ 2pcs	⑳ 1pc
				
㉑ 1pc	㉒ 2pcs	㉓ 1pc	㉔ 1pc	㉕ 1pc
				
㉖ 2pcs	㉗ 2pcs	㉘ 2pcs	㉙ 2pcs	

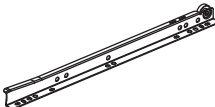
Hardware

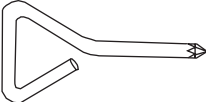
			
Cam Bolt	Cam Lock	∅6x30mm Dowel	M4x40mm Screw
(A) 40pcs	(B) 40pcs	(C) 52pcs	(D) 14pcs
			
M4x30mm Screw	M4x25mm Screw	M3x12mm Screw	
(E) 26pcs	(F) 2pcs	(G) 20pcs	(H) 2pcs
			
		M4x14mm Screw	
(J) 1pc	(K) 2pcs	(L) 2pcs	(M) 2pcs
			
(CL) 2pcs	(CR) 2pcs	(DL) 2pcs	(DR) 2pcs
			
(N) 40pcs	(P) 1pc		

1

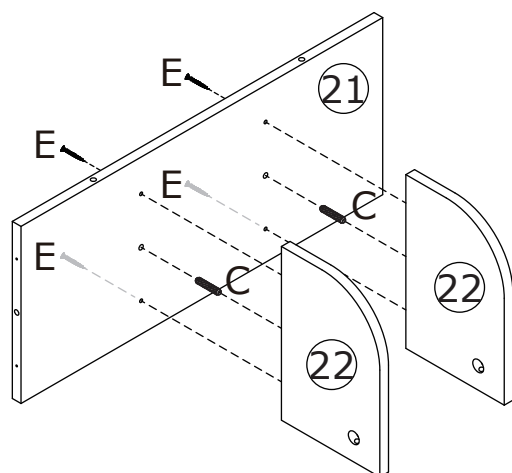
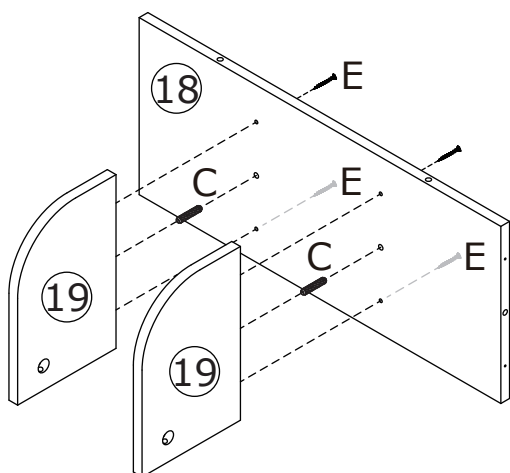
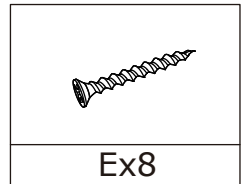
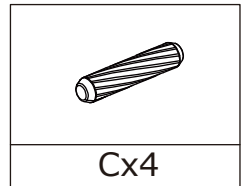
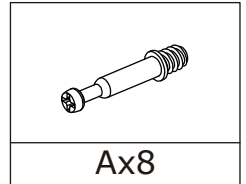
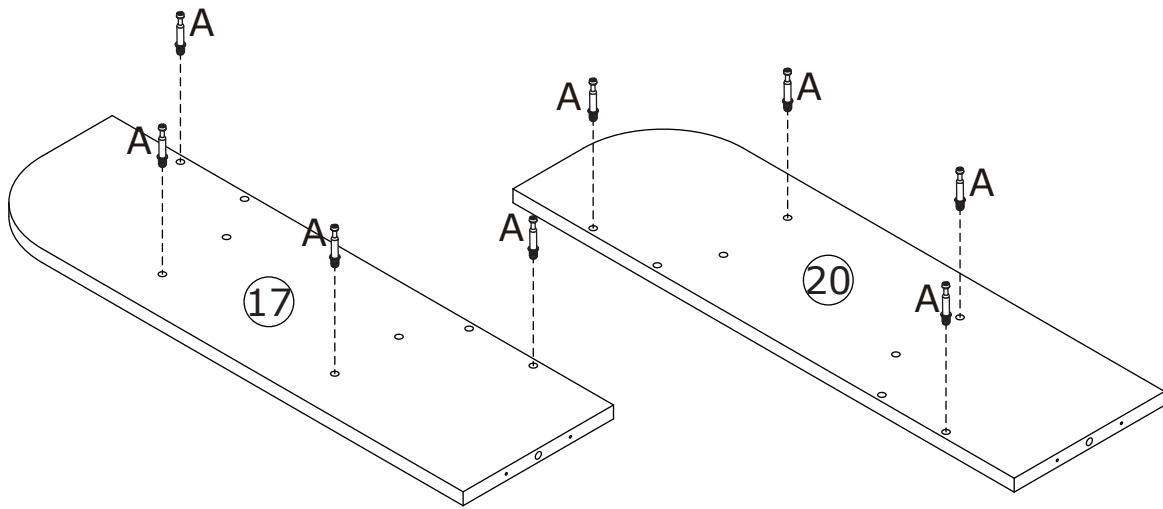

2

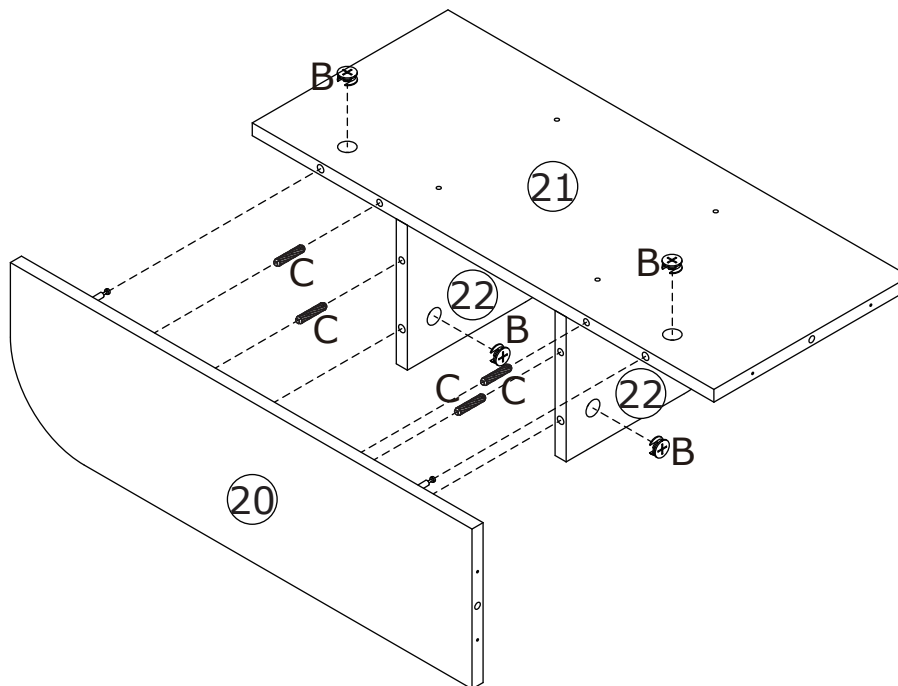
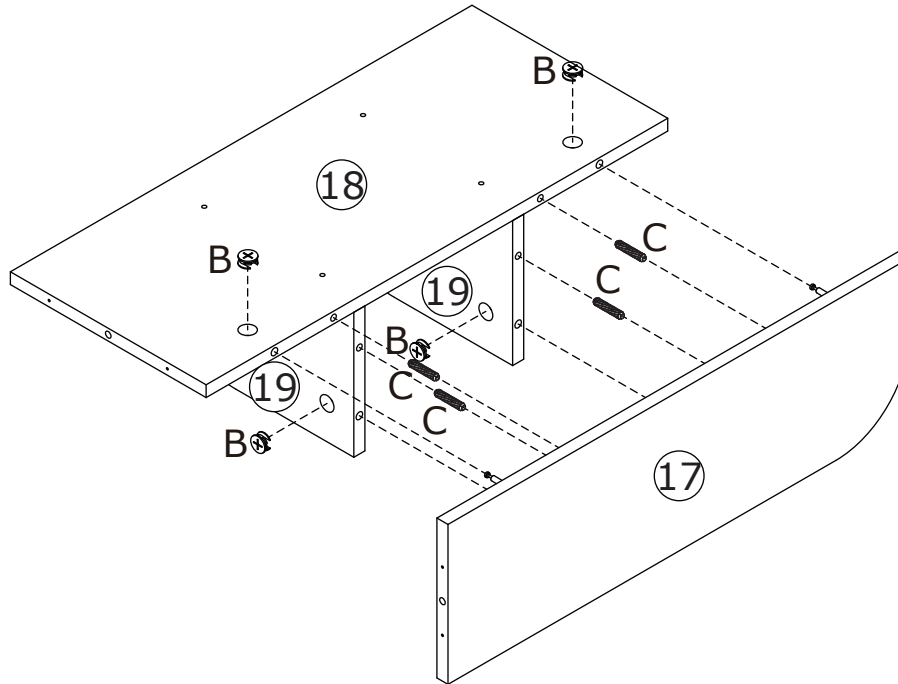
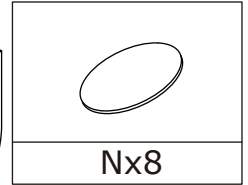
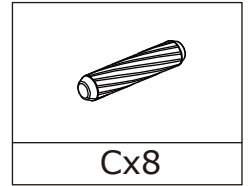
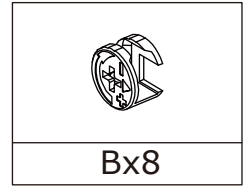
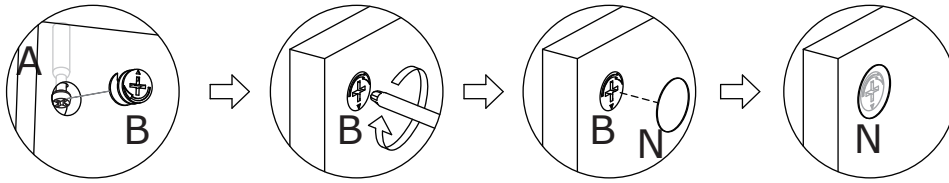

3

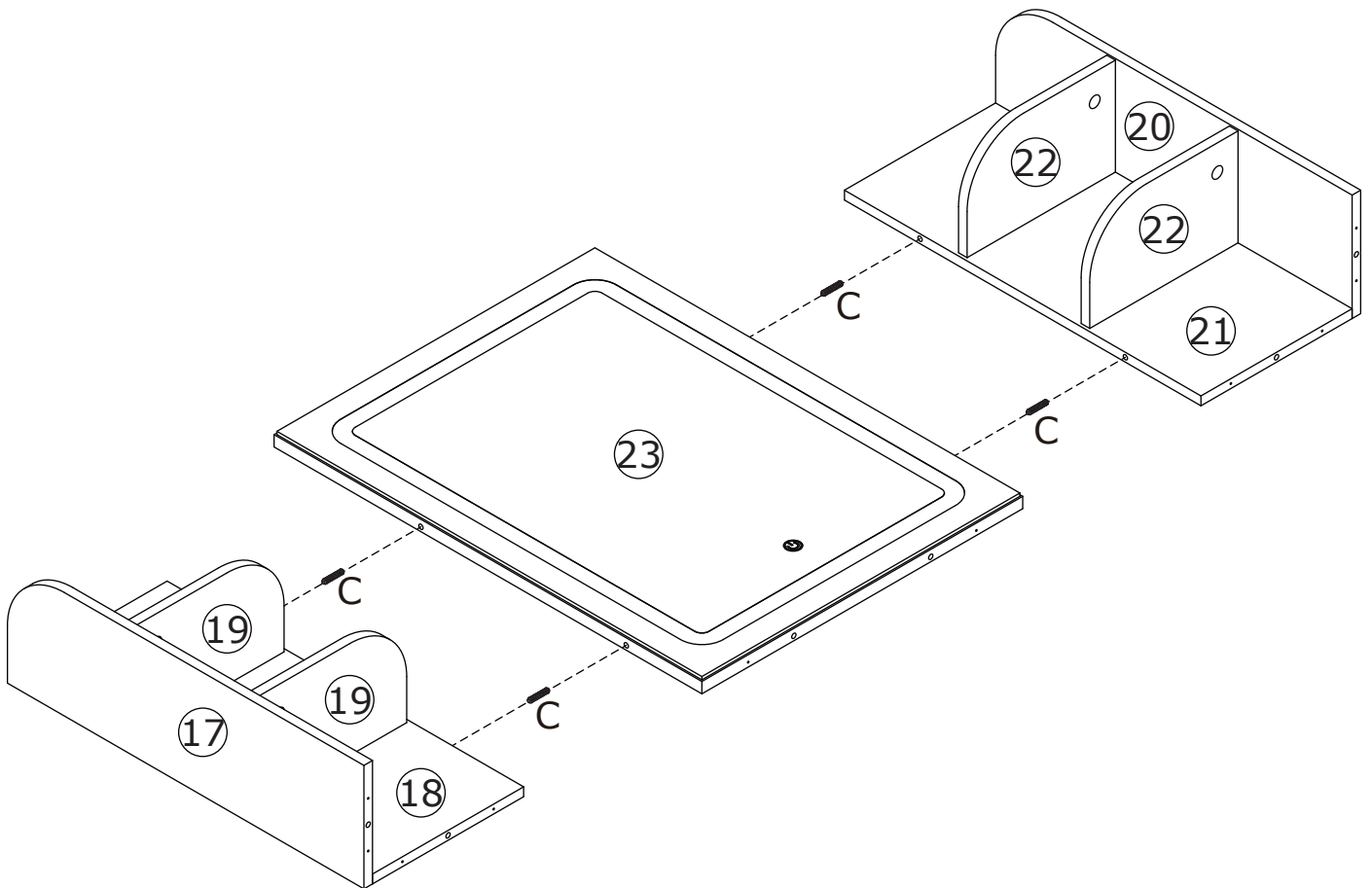
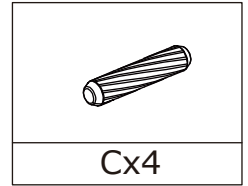

4

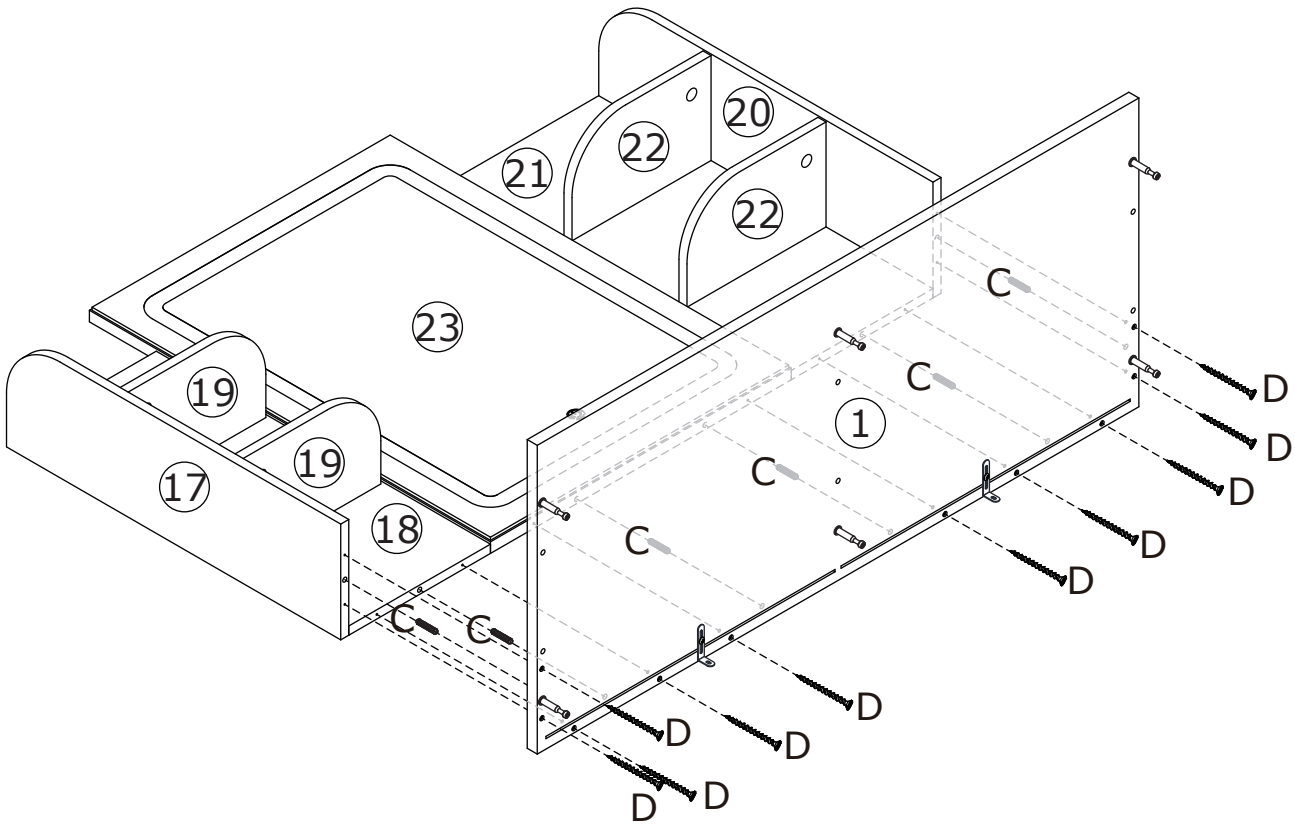
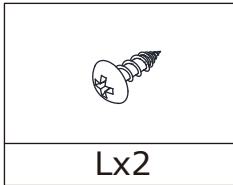
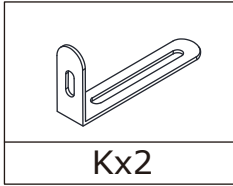
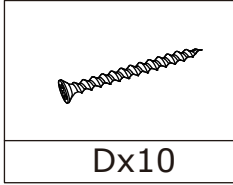
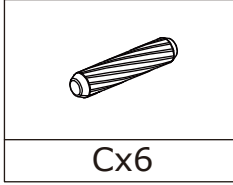
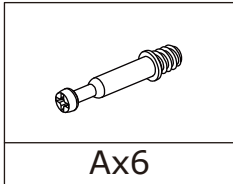
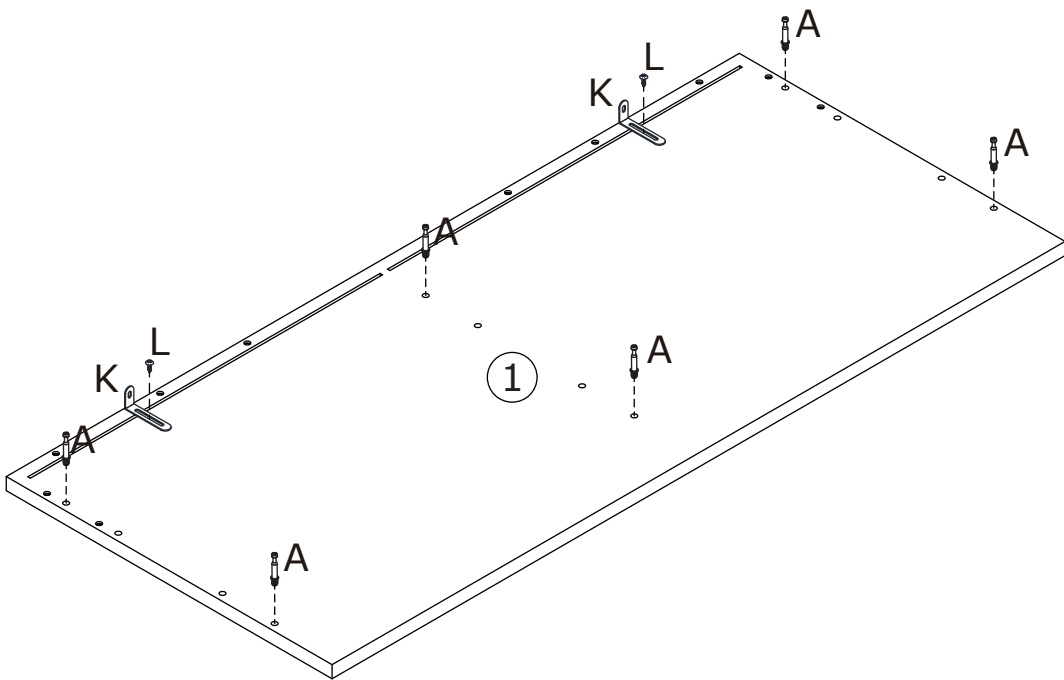

5

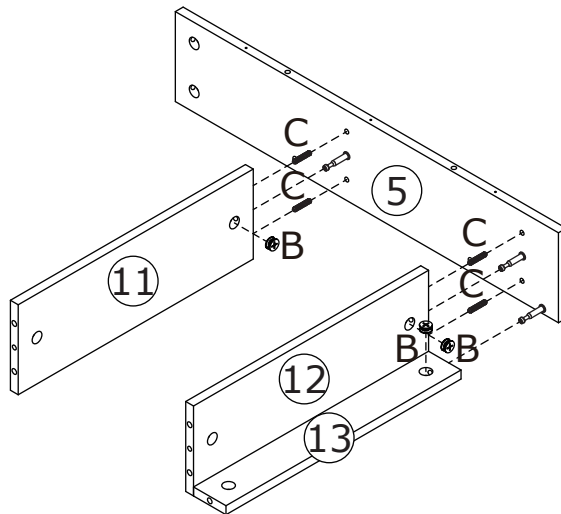
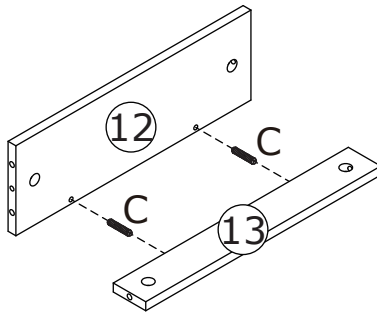
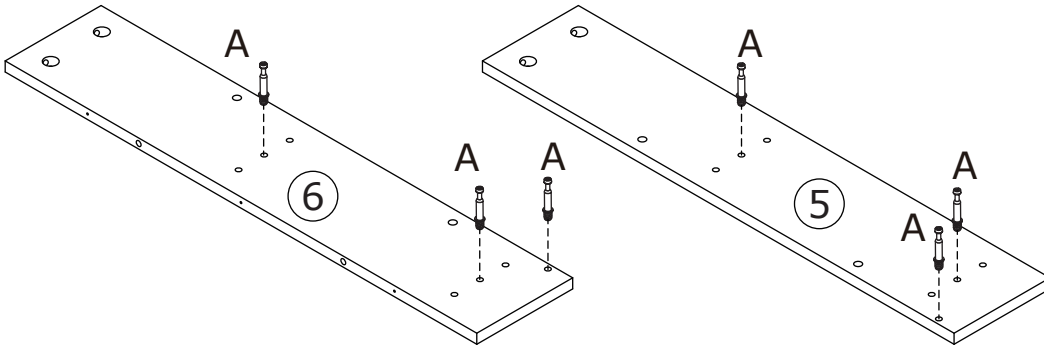
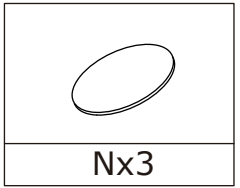
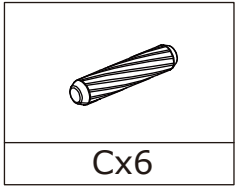
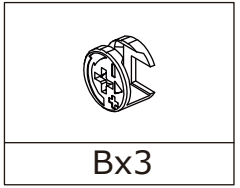
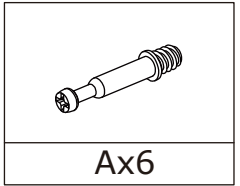
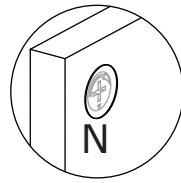
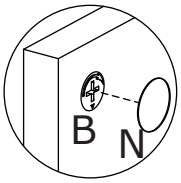
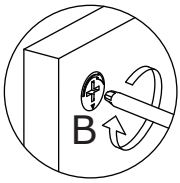
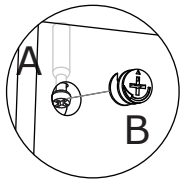

6

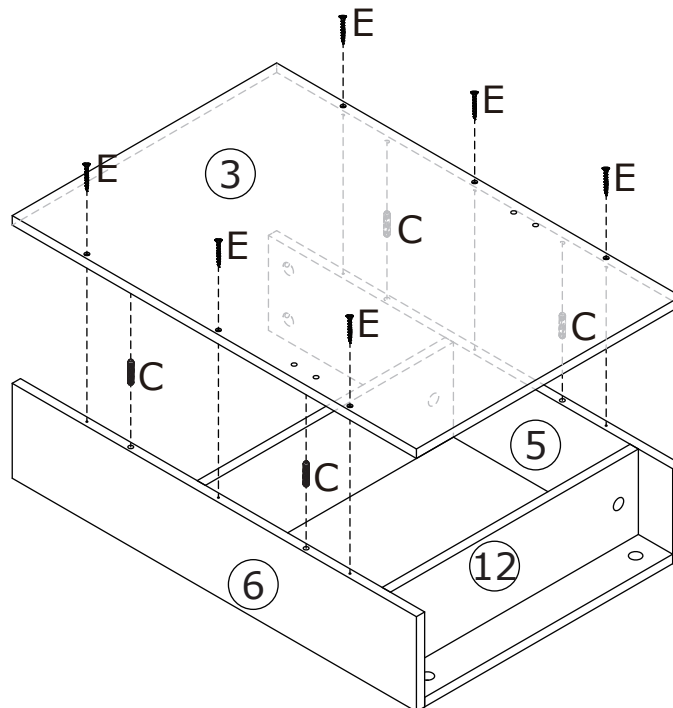
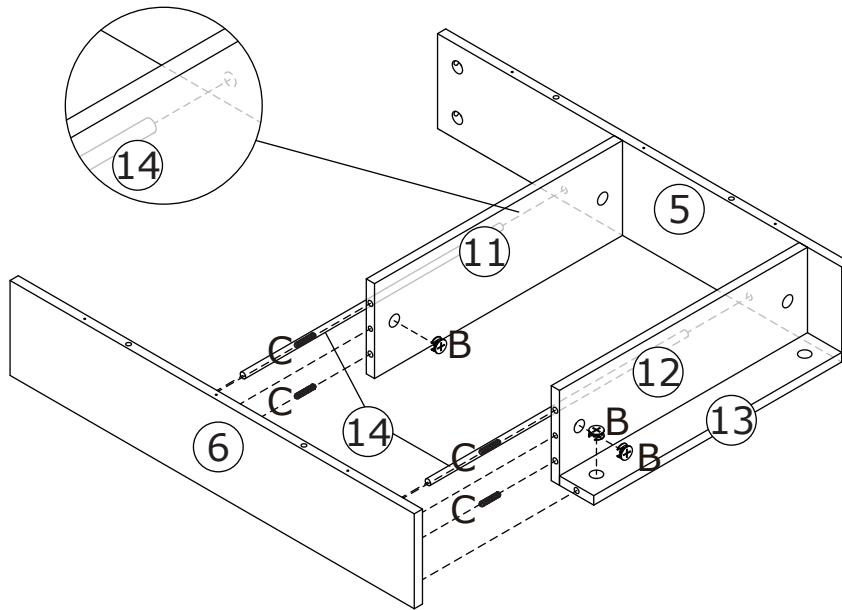
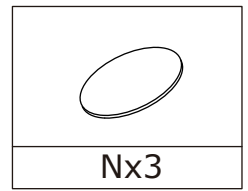
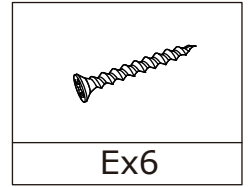
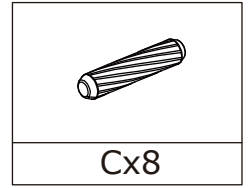
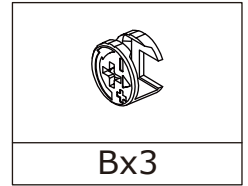
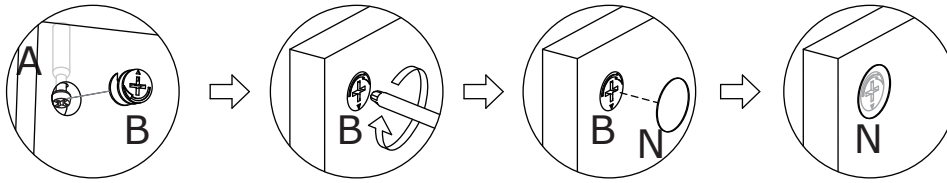

7

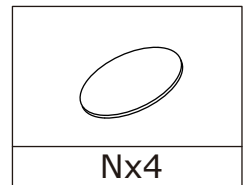
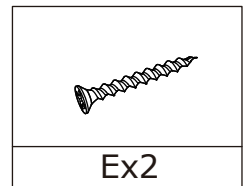
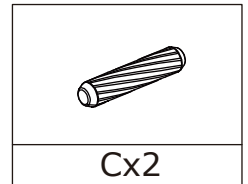
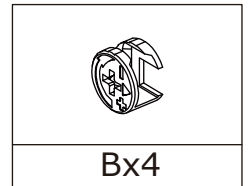
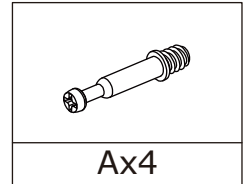
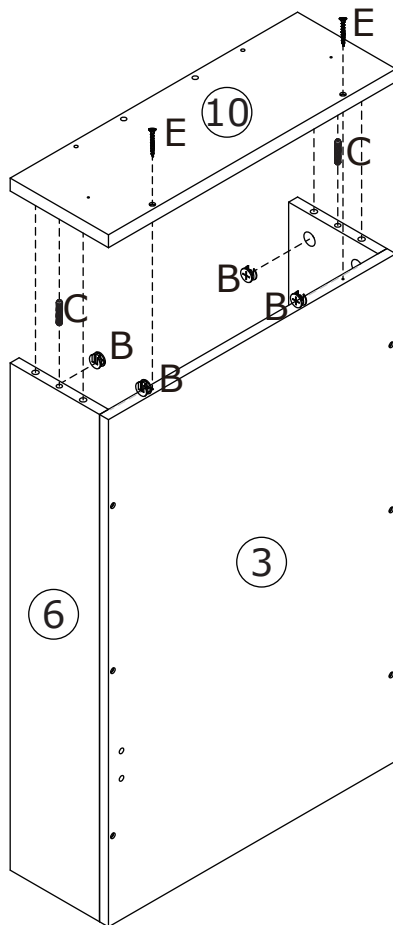
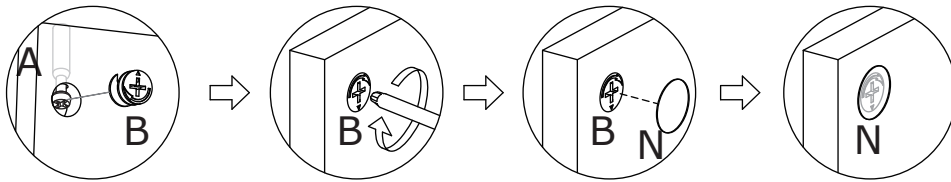
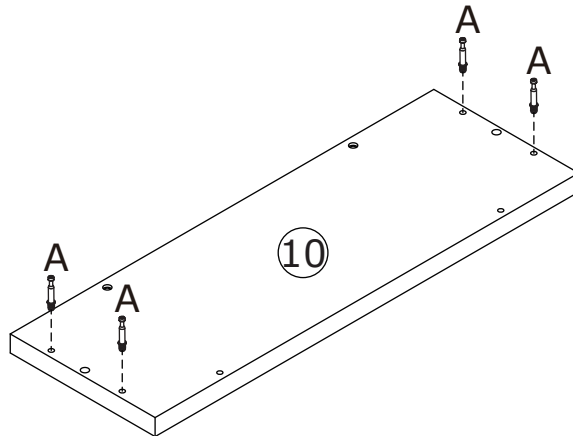

8

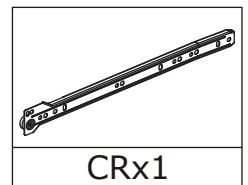
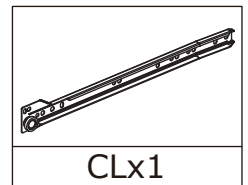
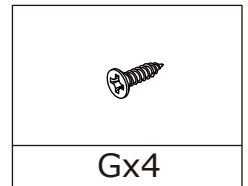
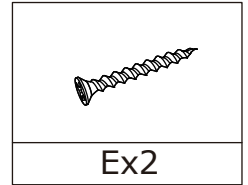
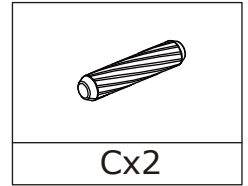
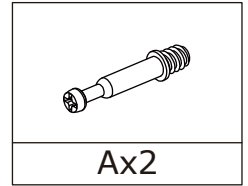
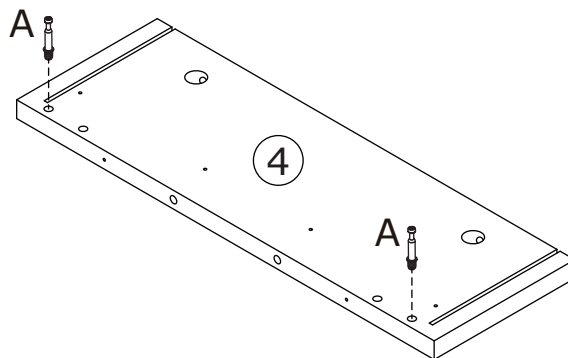
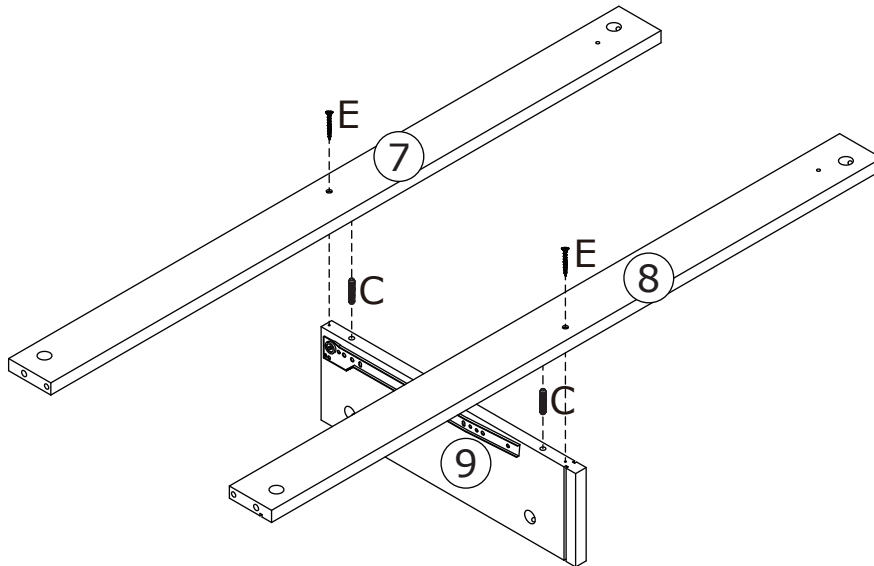
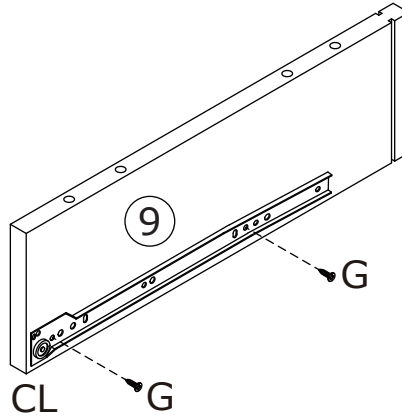
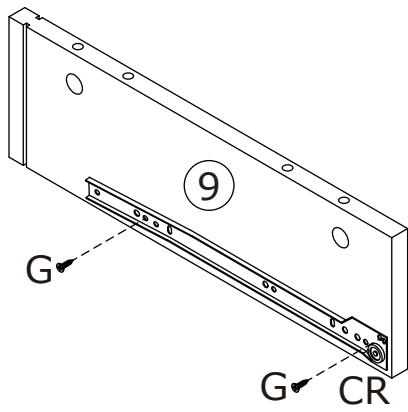
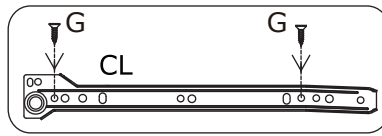
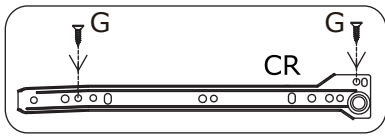

9

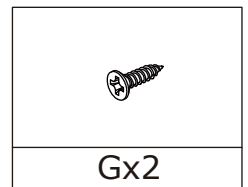
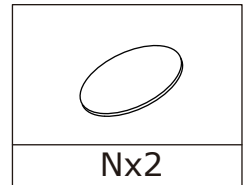
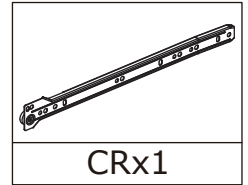
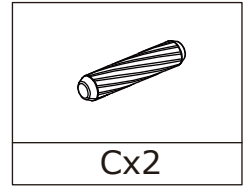
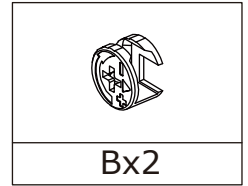
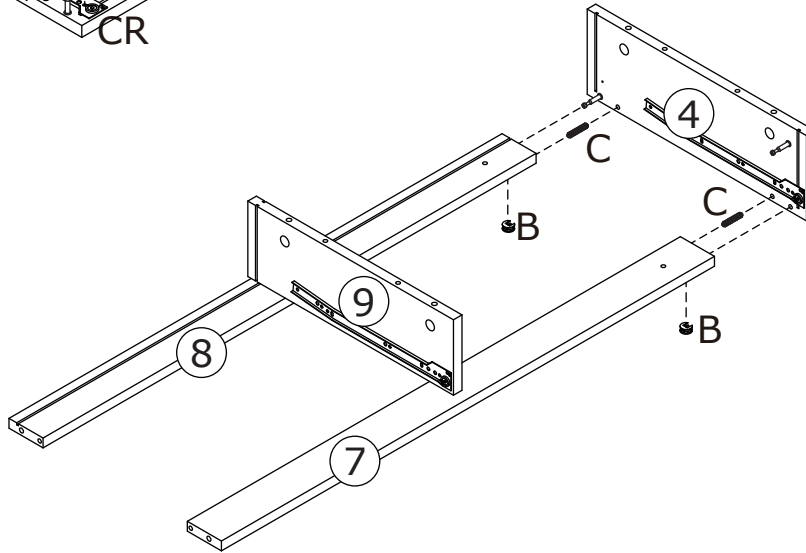
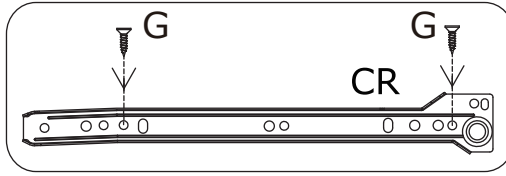
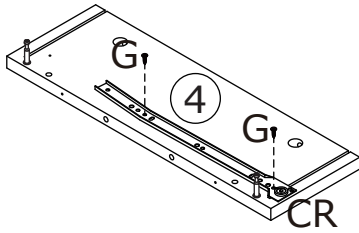
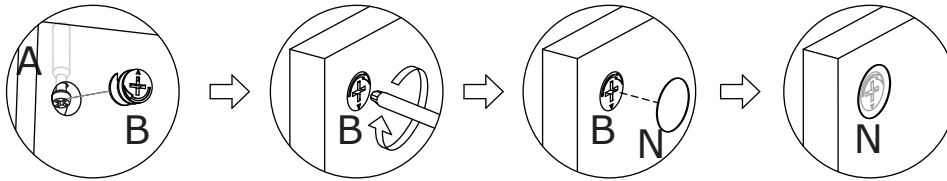

9-1

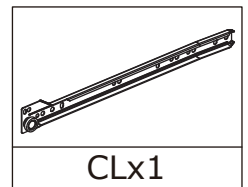
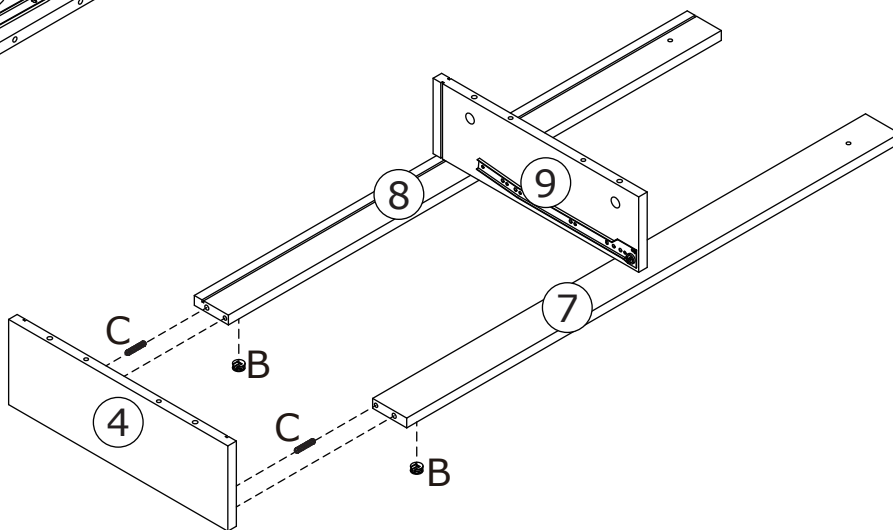
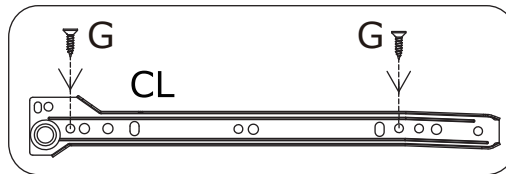
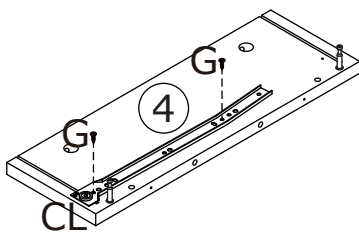

10

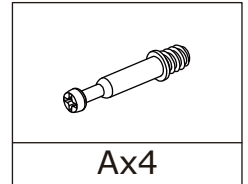
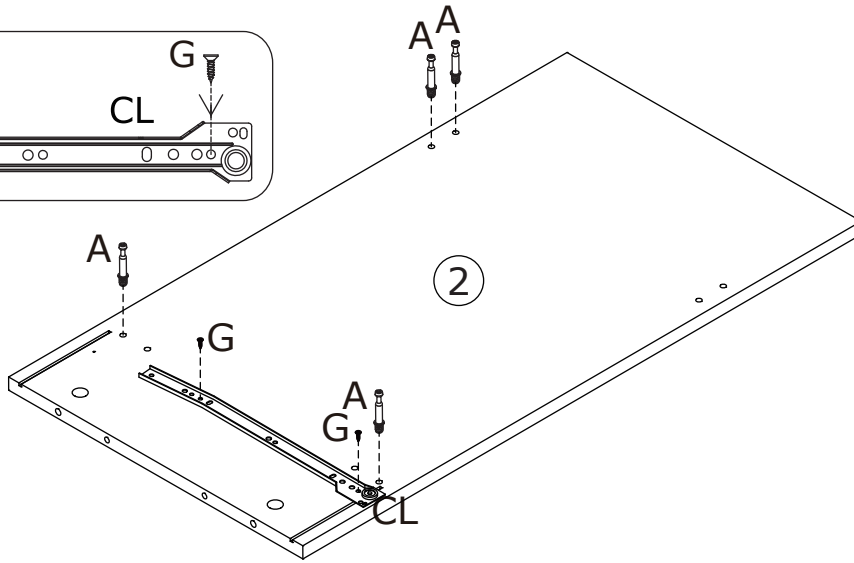
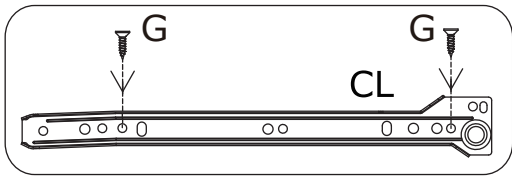

Ax4

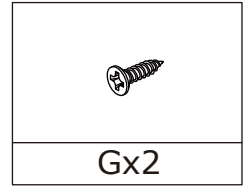

Gx2

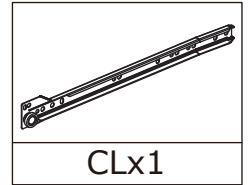

CLx1

10-1

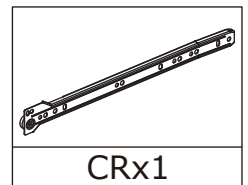
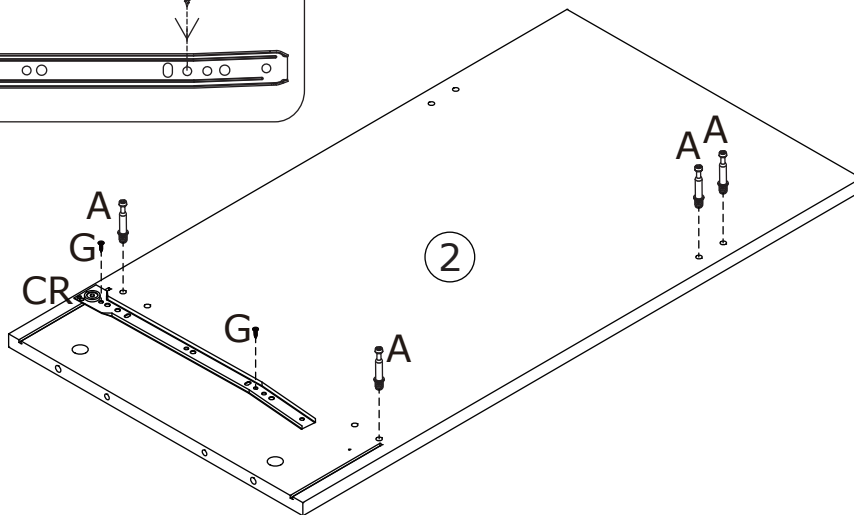
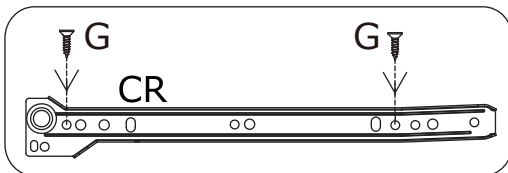

CRx1

11

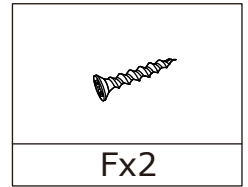
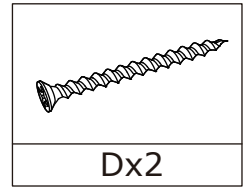
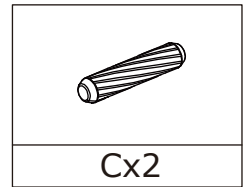
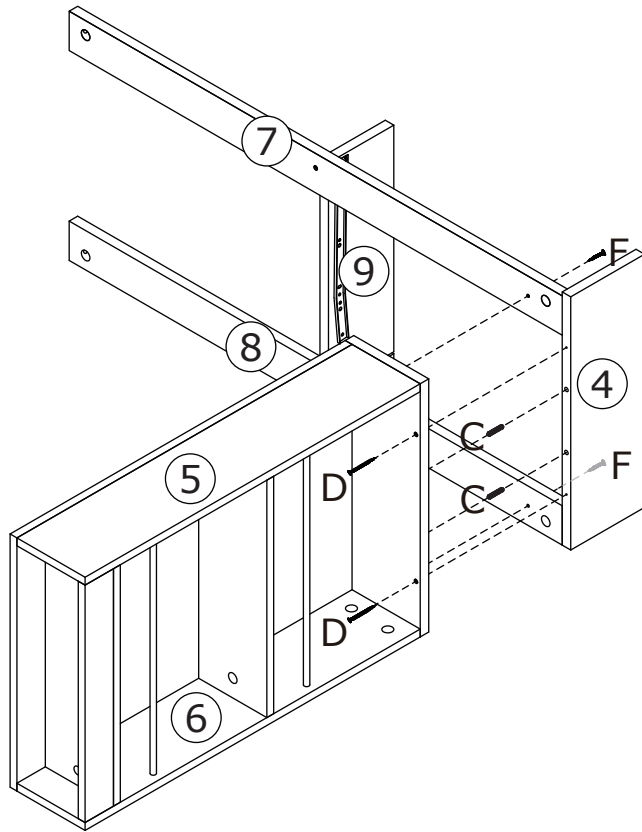

11-1

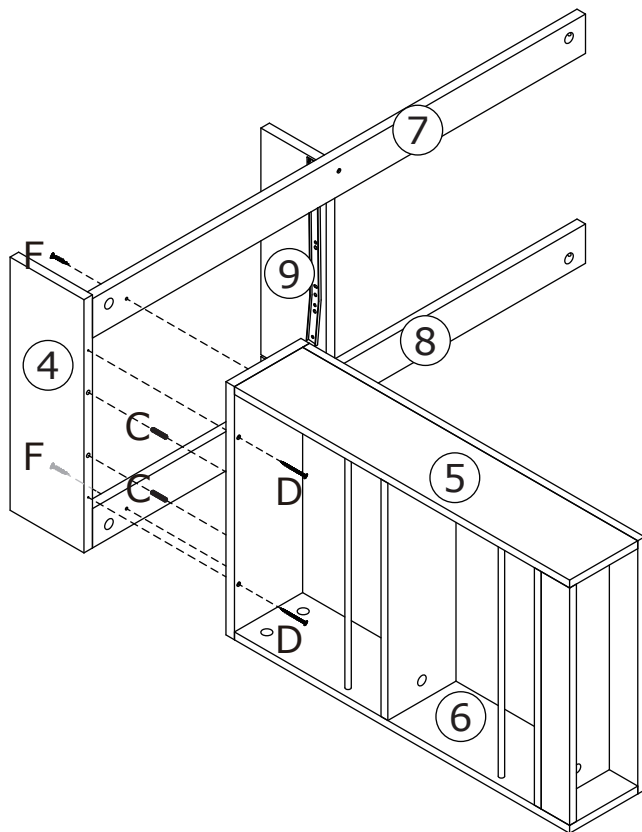

12

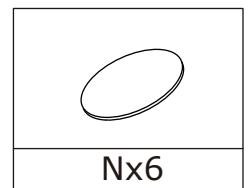
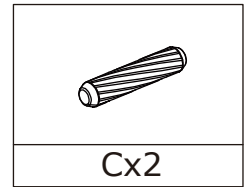
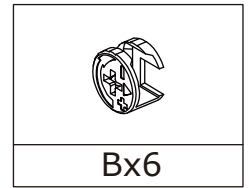
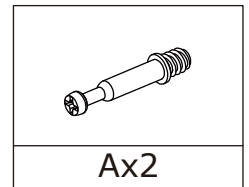
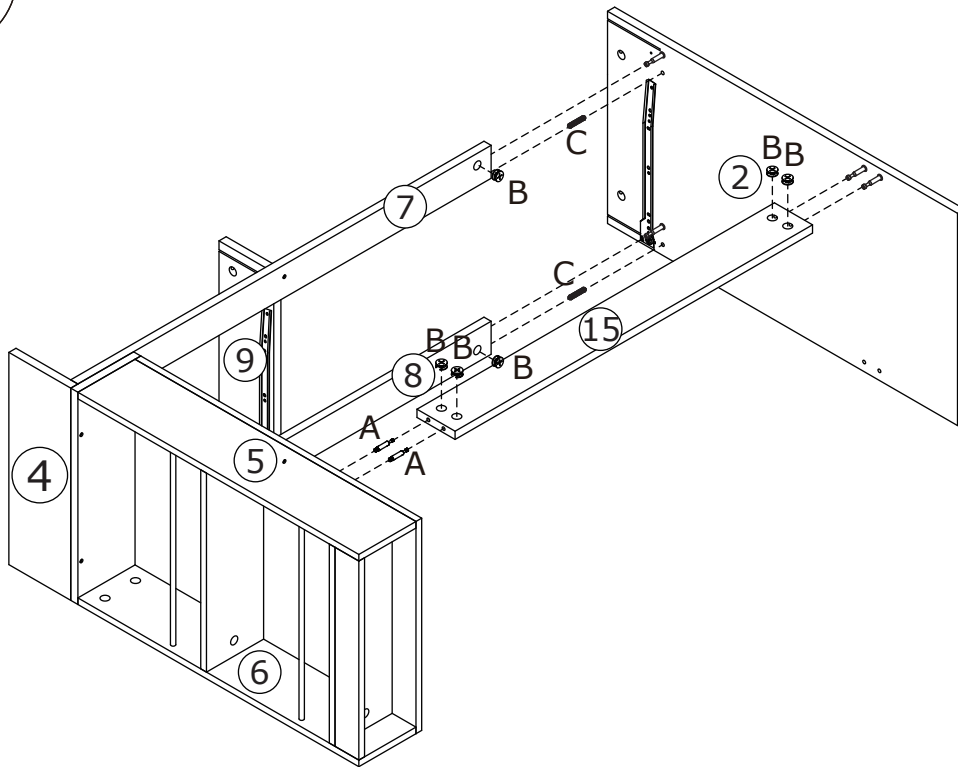

12-1

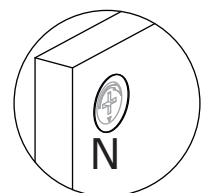
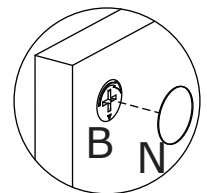
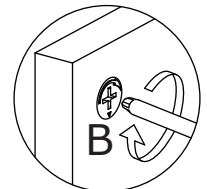
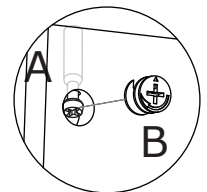
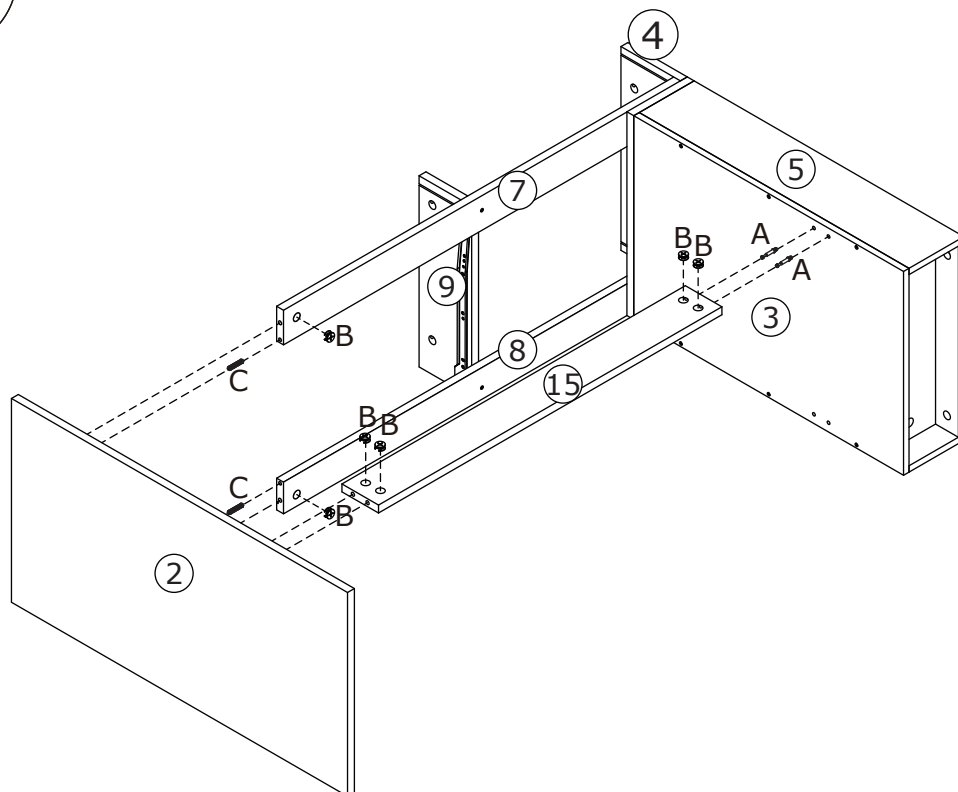

13

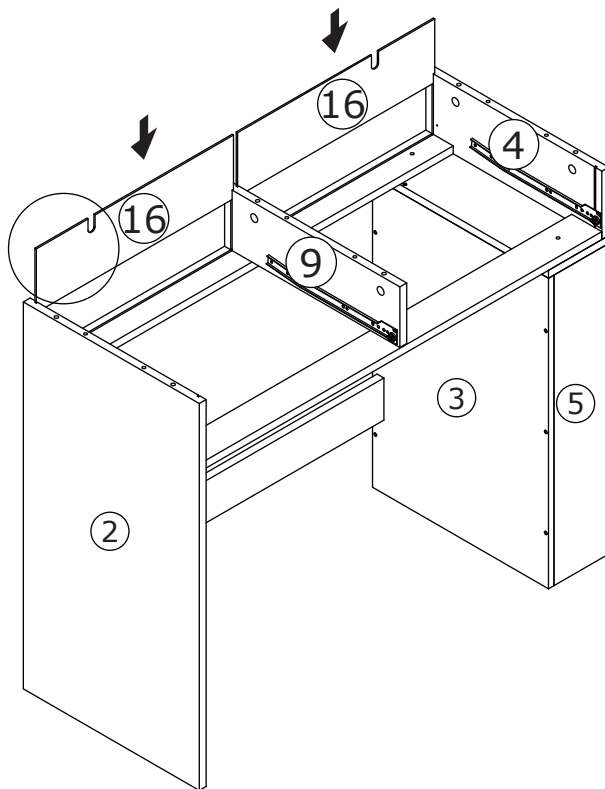
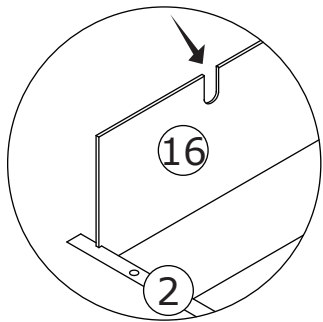

13-1

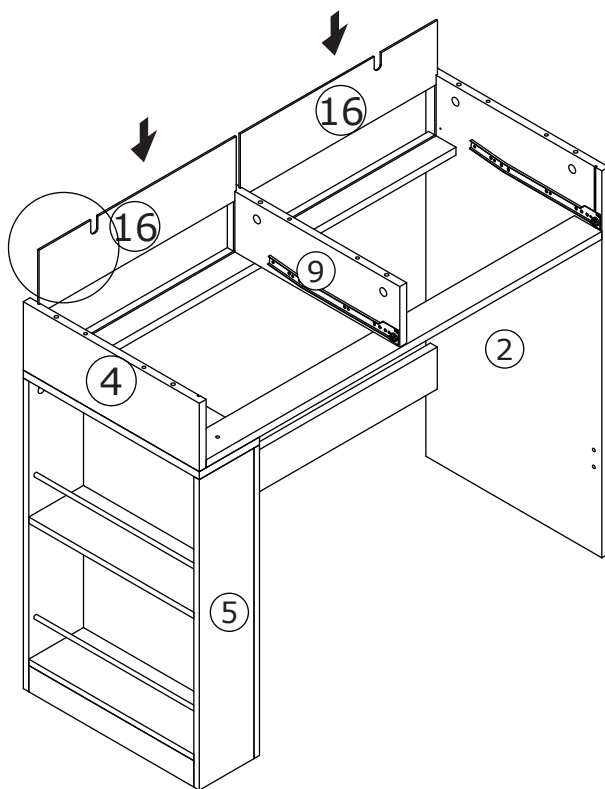
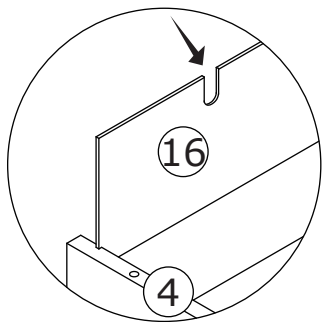

14

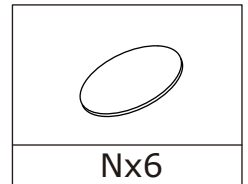
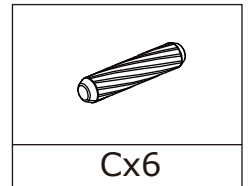
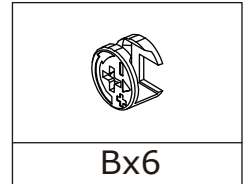
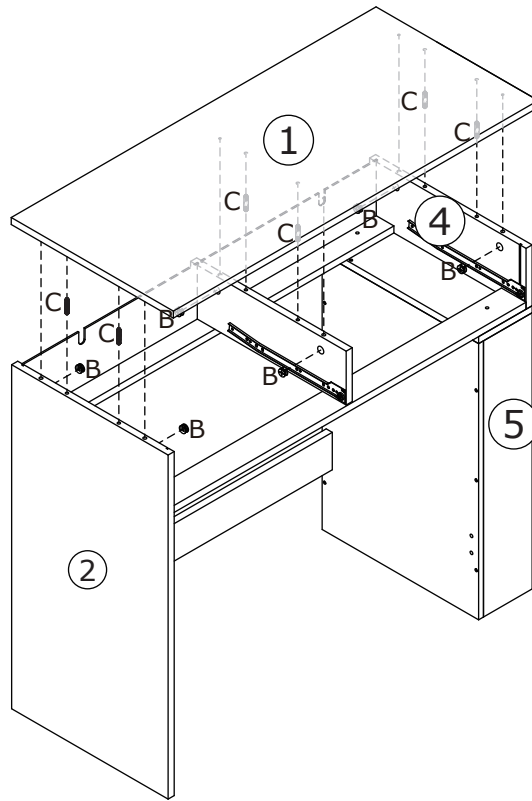
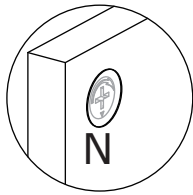
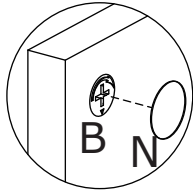
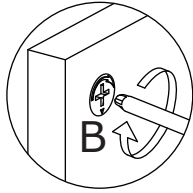
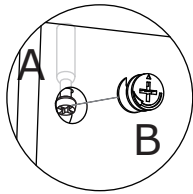

14-1

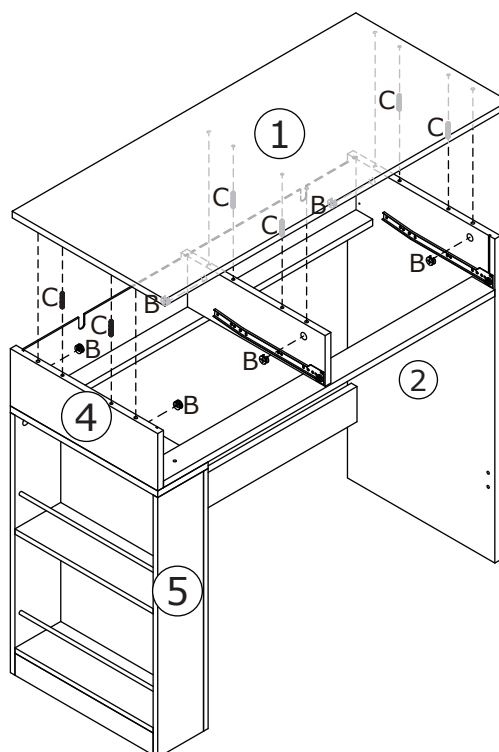

15

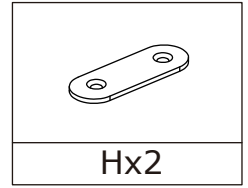
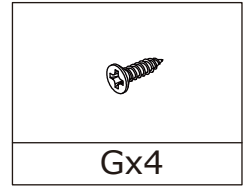
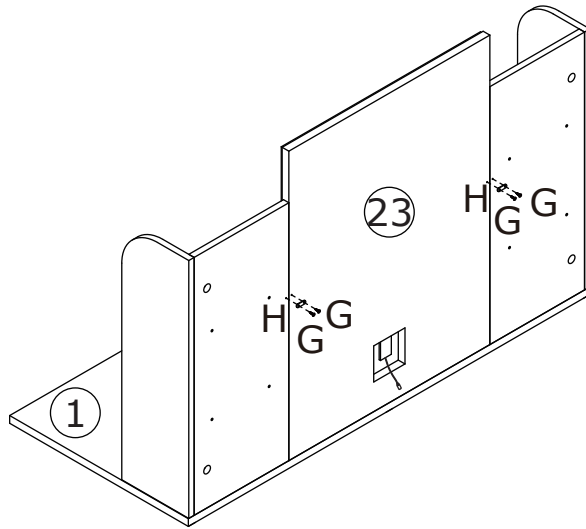

15-1

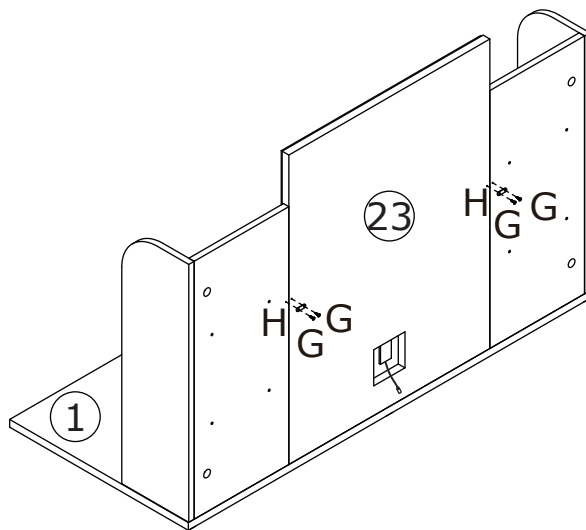
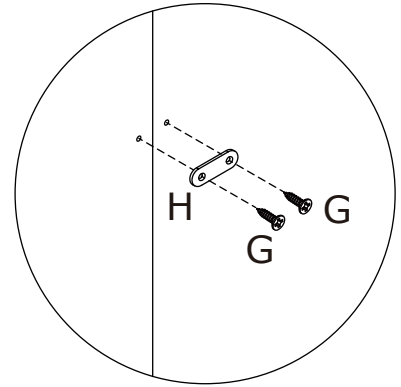

16

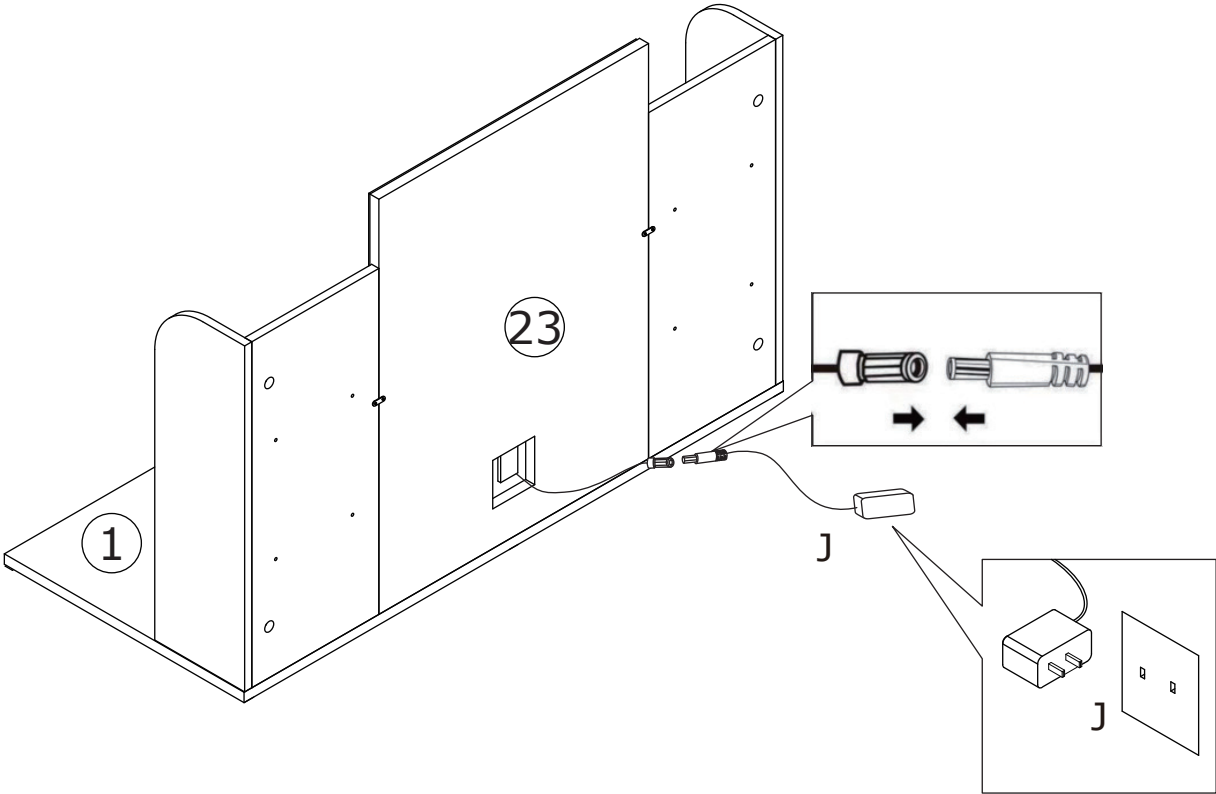
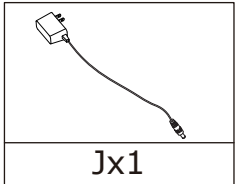

17

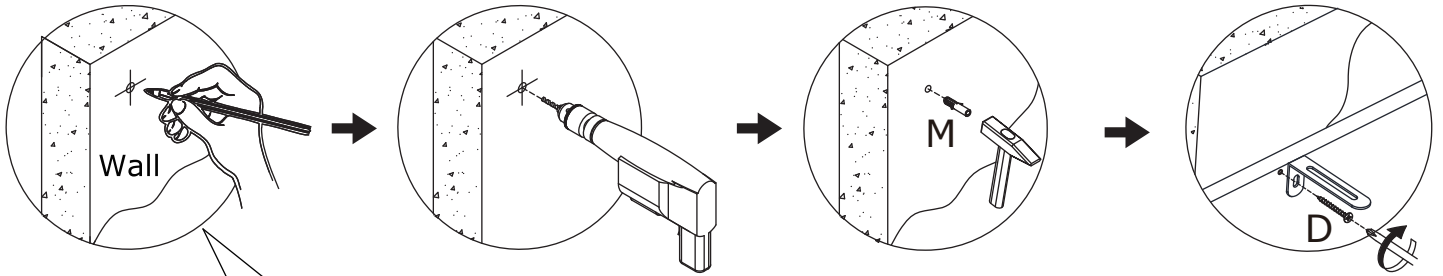
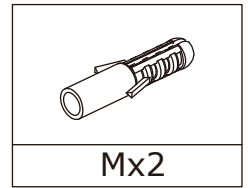
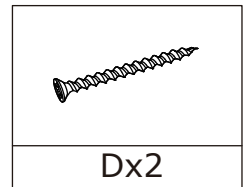

Wall

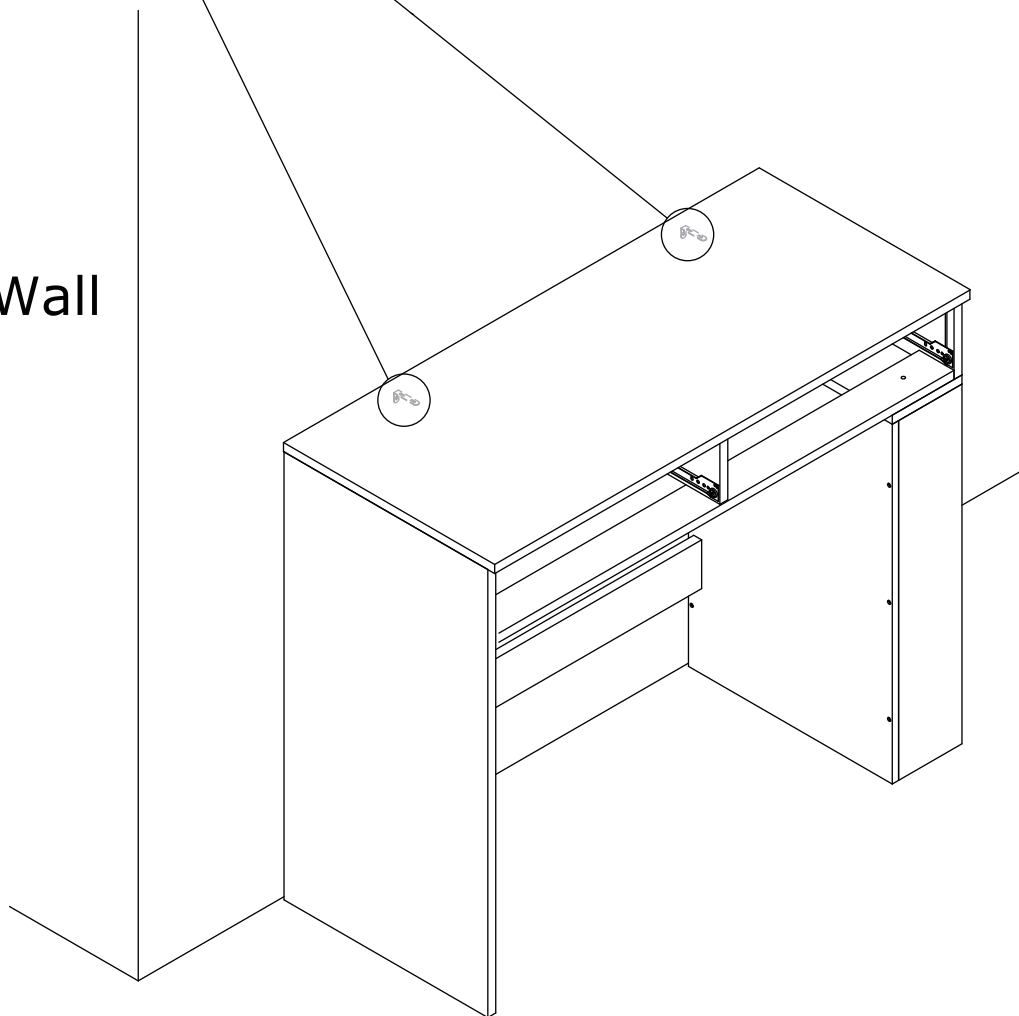

18

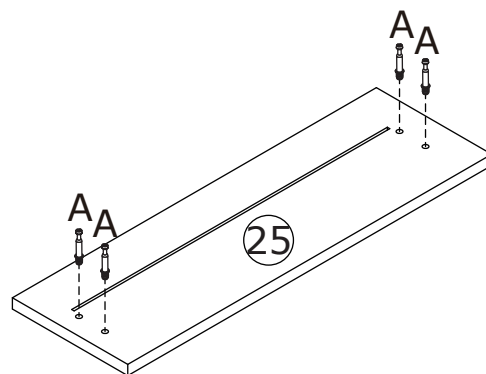
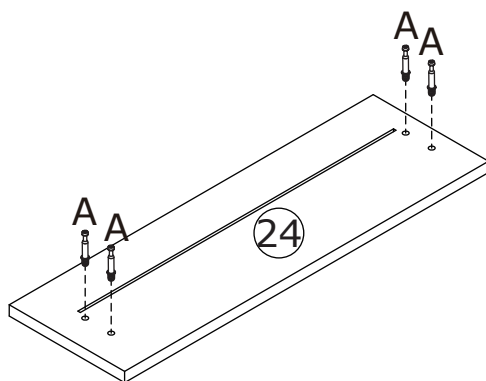
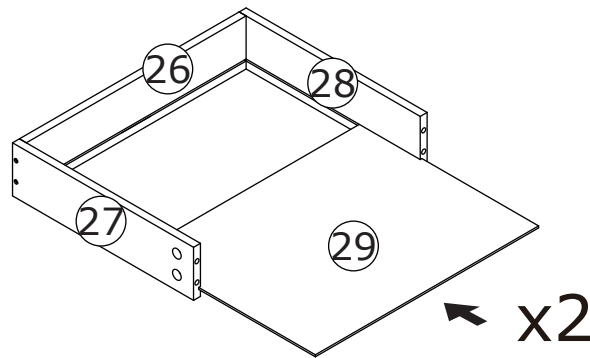
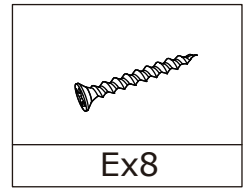
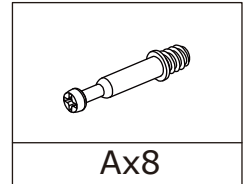
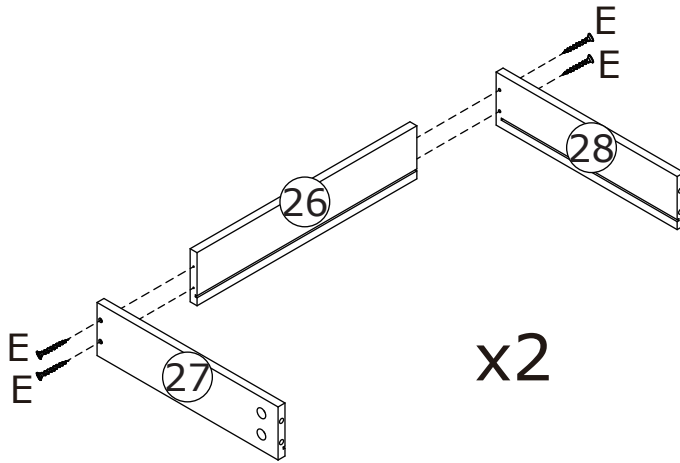

19

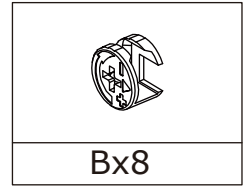
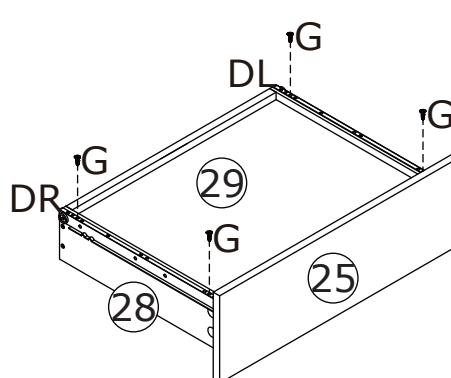
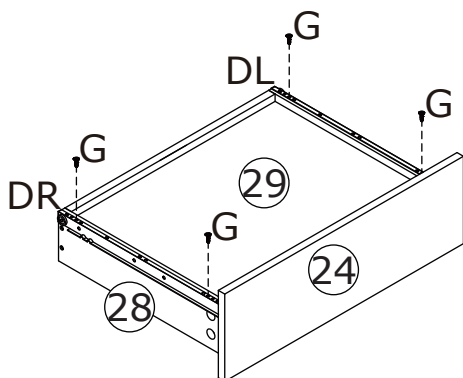
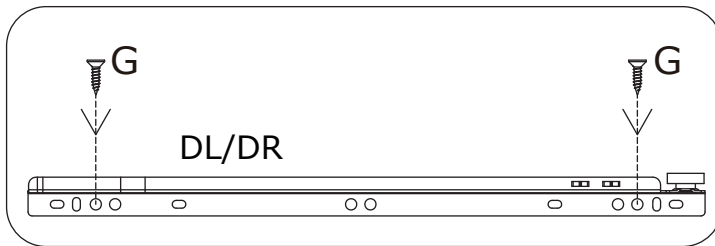
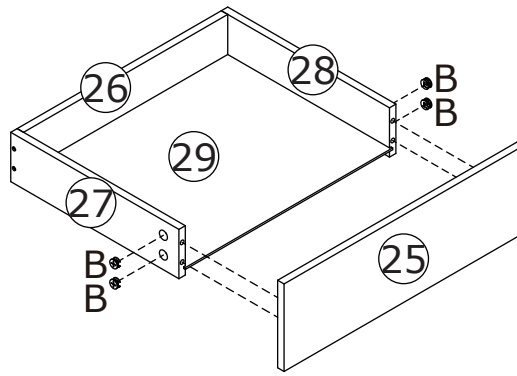
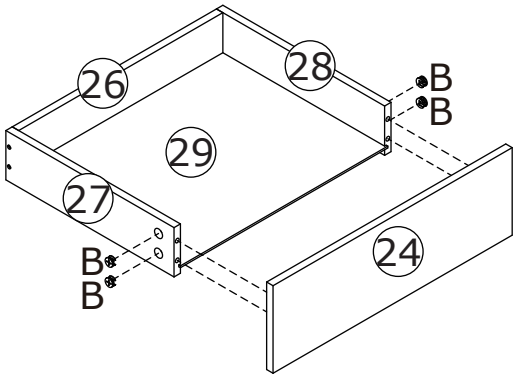

Bx8

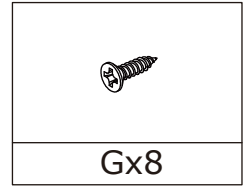

Gx8

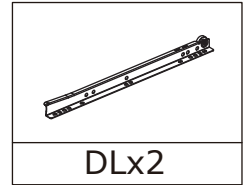

DLx2

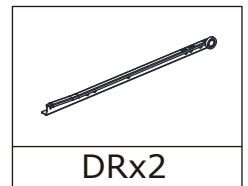

DRx2

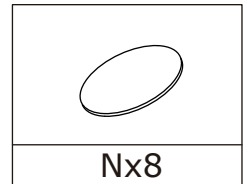

Nx8

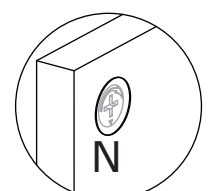
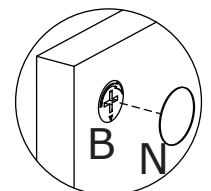
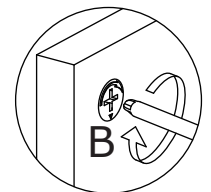
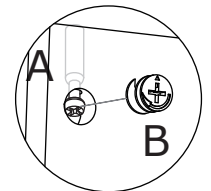

20

Wall

