

ASSEMBLY INSTRUCTIONS

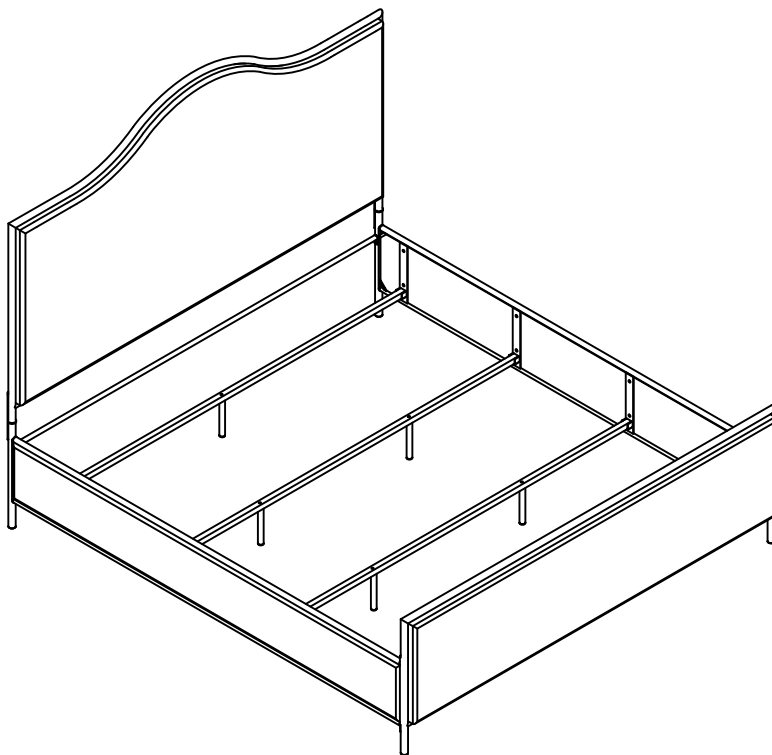

TOOLS REQUIRED



Allen Wrench
(Included)



3 - Persons

ASSEMBLY RATING



EASY ————— DIFFICULT

The Assembly Rating is a 5-point system showing the level of effort needed to assemble a specific product.



CHECK BEFORE STARTING

Are you missing anything?

Double-check all parts, hardware and accessories listed are all accounted for.

Check out our Quick Tips!

We recommend reviewing the pre-assembly handouts. Even experts need a refresher now and then!

Should we send any replacements?

Are there any irregularities or flaws in the parts? We can send replacements!

Prep Time!

Please review the assembly instructions and all diagrams prior to assembling.

PRE ASSEMBLY INTRODUCTION

We understand building ready-to-assemble furniture can be a challenging experience for some. To help avoid confusion, we have provided some helpful tips that may speed up the process.

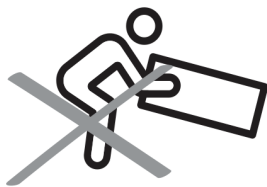

Teamwork

ALWAYS have at least two people to help with transporting and assembling the product to avoid potential injury and/or damage.

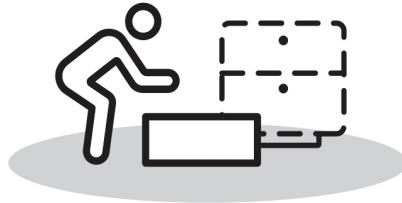
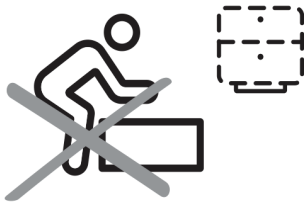

Suitable Location

Assembling near the area of the intended location is highly recommended.



Sufficient Space

Make sure you have enough space to move around during the assembly.



Avoid Scratches

Use cardboard, blankets or a carpeted area while assembling furniture to prevent to prevent scratches and damages.



Flat Surface

Make sure the furniture rests on a flat and level surface with each leg evenly touching the floor.

ASSEMBLY AND CARE ADVICE



FAILURE TO FOLLOW THE GUIDELINES BELOW MAY RESULT IN INJURY AND/OR PROPERTY DAMAGE.



Position each part correctly and insert screws or bolts into their respective holes.

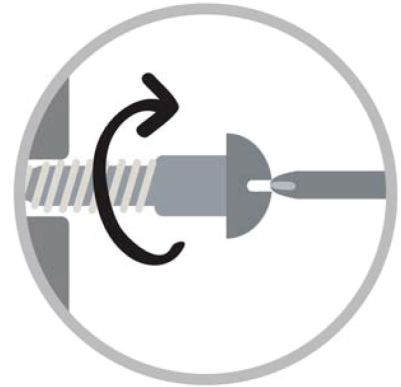

Turn clockwise to tighten and only tighten when step is completed or when instructed to do so.



Use the appropriate hand tools or power tools for assembly. Select steps, such as tightening screws and/or bolts, may require hand tools to avoid causing damage during assembly.



Save the instructions and store any supplied tools for later maintenance.



After two weeks, check and tighten any loose hardware and repeat again every six months thereafter.

IT IS THE USER'S RESPONSIBILITY TO MAINTAIN THE FURNITURE. THE HARDWARE MAY LOOSEN OVER TIME AND MAY CAUSE THE FURNITURE TO BE WOBBLY AND UNABLE TO SUPPORT ITS INTENDED WEIGHT CAPACITY. THIS MAY LEAD TO COLLAPSE AND MAY CAUSE SERIOUS INJURY.

BED



- Please keep instructions for future reference.
- Check the quantity and irregularity of parts and hardware before you start.

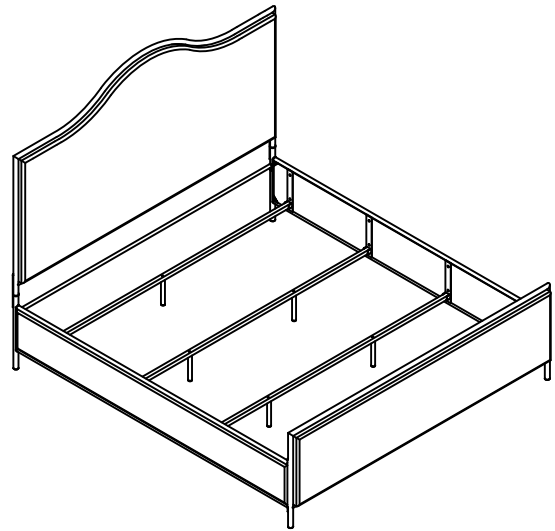

PARTS

1

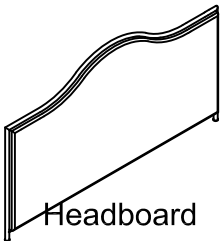

Headboard
1 pc

2

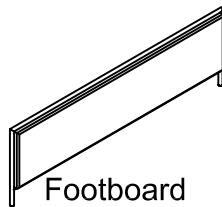

Footboard
1 pc

3

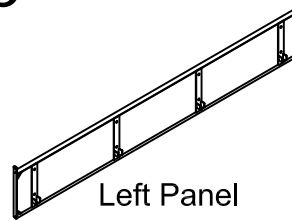

Left Panel
1 pc

4

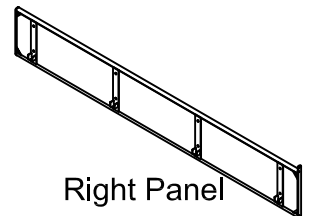

Right Panel
1 pc

5



Headboard Leg 1
1 pc

6



Headboard Leg 2
1 pc

7

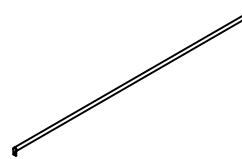

Cross Bar
1 pc

8

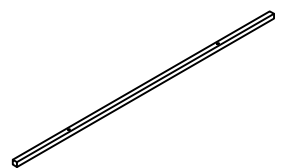

Slat 1
2 pcs

9

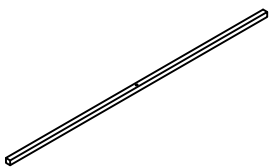

Slat 2
2 pcs

10



Bracket 1
2 pcs

11

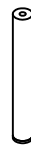

Support Leg
6 pcs

12

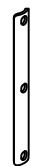

Bracket 2
2 pcs

HARDWARE

A



Bolt 1/4" x 1/2"
10 pcs

B



Bolt 1/4" x 3/4"
12 pcs

C



Bolt 1/4" x 1-3/4"
10 pcs

D



Flat Washer Ø16mm
32 pcs

E



Allen Wrench
4 x 22 x 60 mm
1 pc

ASSEMBLY INSTRUCTIONS

1

- Part #5 x1pc
- Part #6 x1pc
- Part #7 x1pc
- Hardware #A x2pcs
- Hardware #D x2pcs
- Hardware #E x1pc

Align each end of the cross bar (#7) to the holes along the headboard legs (#5, #6). Insert a bolt (#A) with flat washers (#D) Allen Wrench (#E) into each hole.

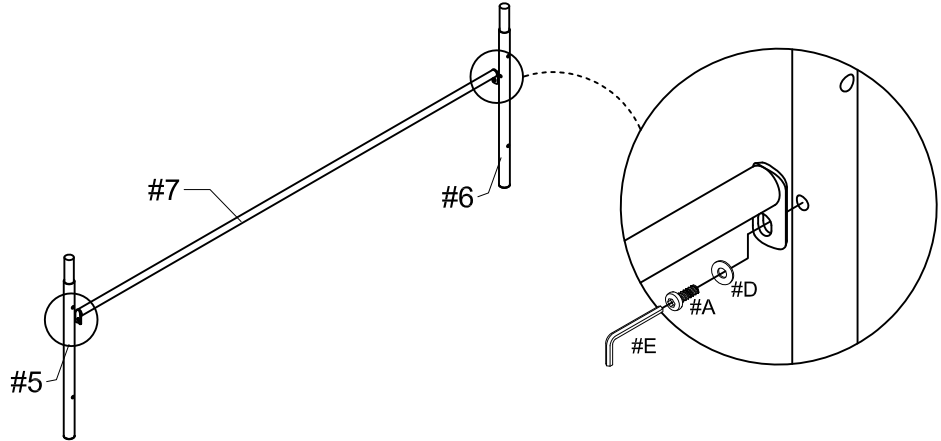

Note:
Do not fully tighten all bolts until assembly is complete. This will help all parts to assemble properly.

2

- Part #1 x1pc
- Part #12 x2pcs
- Hardware #B x4pcs
- Hardware #D x4pcs
- Hardware #E x1pc

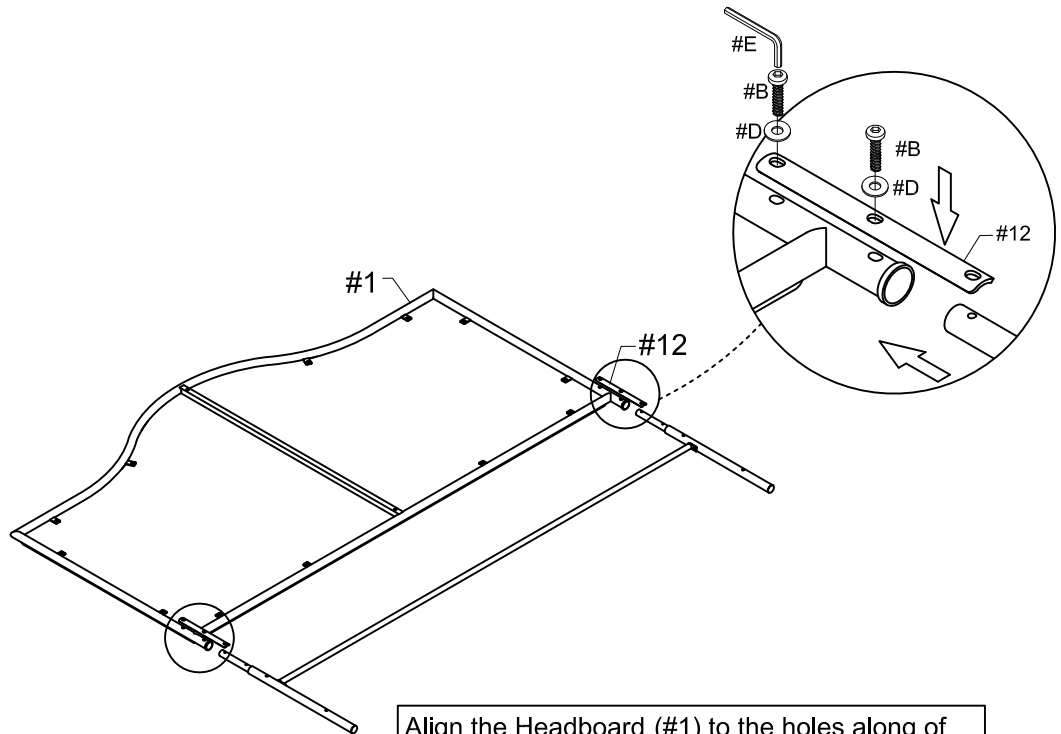

Align the Headboard (#1) to the holes along of the Bracket (#12) headboard legs (#5, #6), then secure by using bolts (#B) Flat Washer (#D) Allen Wrench (#E).

ASSEMBLY INSTRUCTIONS

3

- Part #3 x1pc
- Part #4 x1pc
- Part #10 x2pcs
- Hardware #B x4pcs
- Hardware #D x4pcs
- Hardware #E x1pc

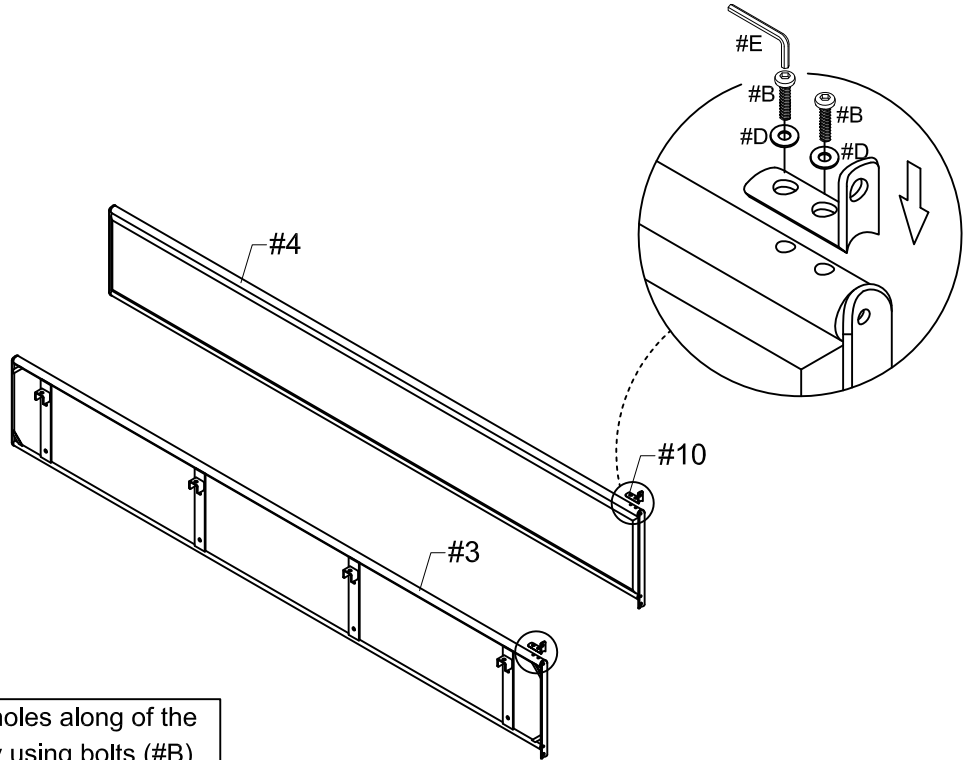

Align the Bracket (#10) to the holes along of the Panel (#3, #4), then secure by using bolts (#B) Flat Washer (#D) Allen Wrench (#E).

4

- Part #2 x1pc
- Hardware #B x4pcs
- Hardware #C x4pcs
- Hardware #D x8pcs
- Hardware #E x1pc

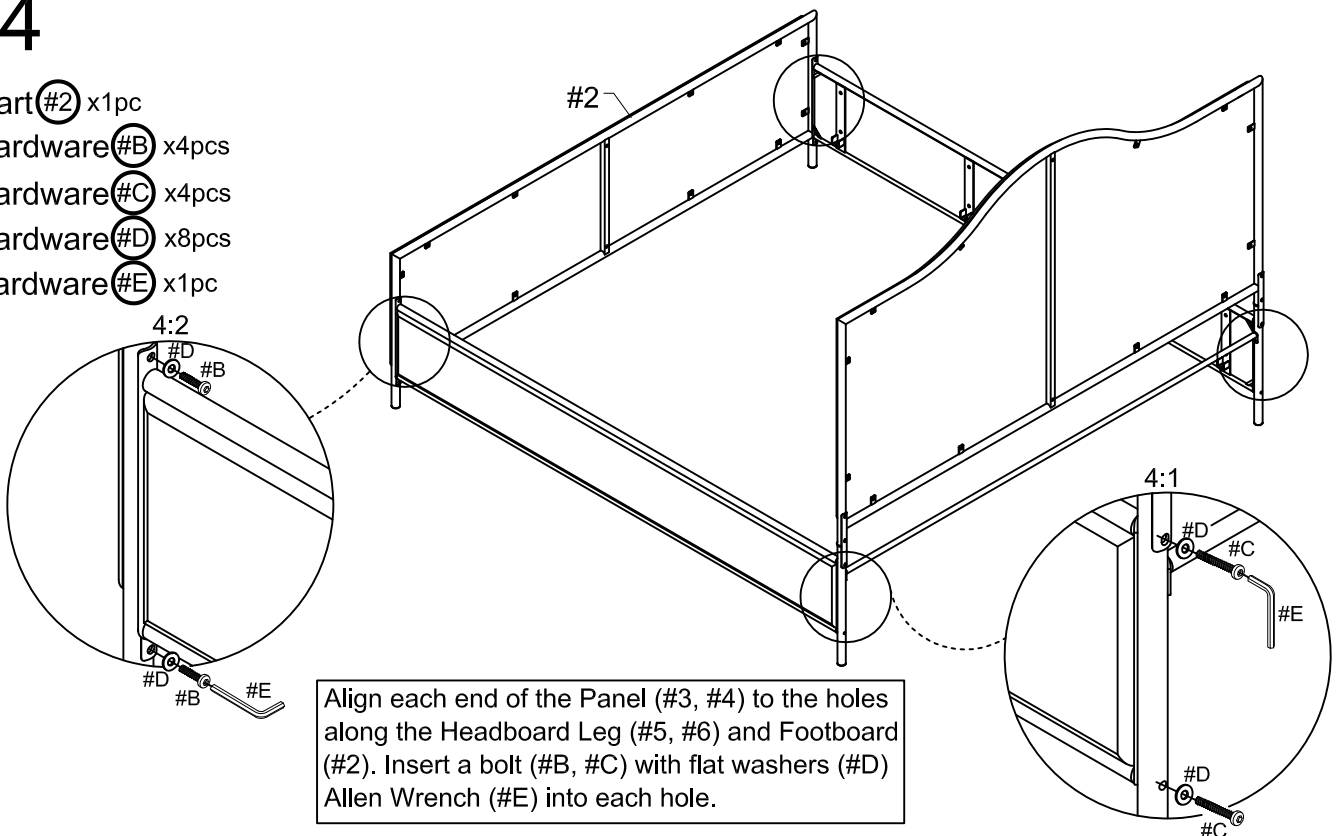

Align each end of the Panel (#3, #4) to the holes along the Headboard Leg (#5, #6) and Footboard (#2). Insert a bolt (#B, #C) with flat washers (#D) Allen Wrench (#E) into each hole.

ASSEMBLY INSTRUCTIONS

5

- Part #8 x2pcs
- Part #9 x2pcs
- Part #11 x6pcs
- Hardware #C x6pcs
- Hardware #D x6pcs
- Hardware #E x1pc

Align the support legs (#11) to the holes along the slats (#8,#9), insert a bolt (#C) with flat washer (#D) Allen wrench (#E) into each hole from above.

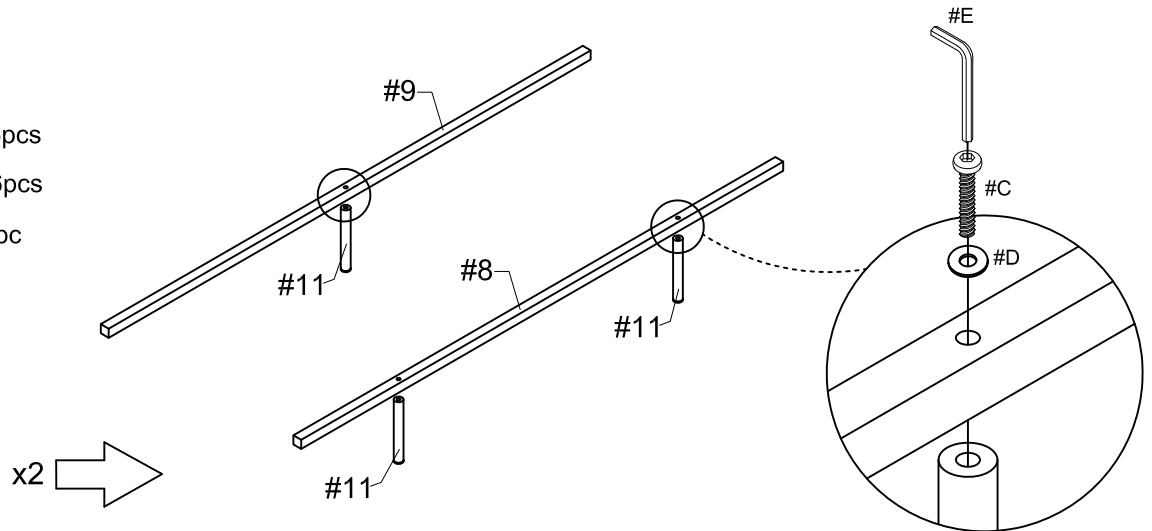

6

- Hardware #A x8pcs
- Hardware #D x8pcs
- Hardware #E x1pc

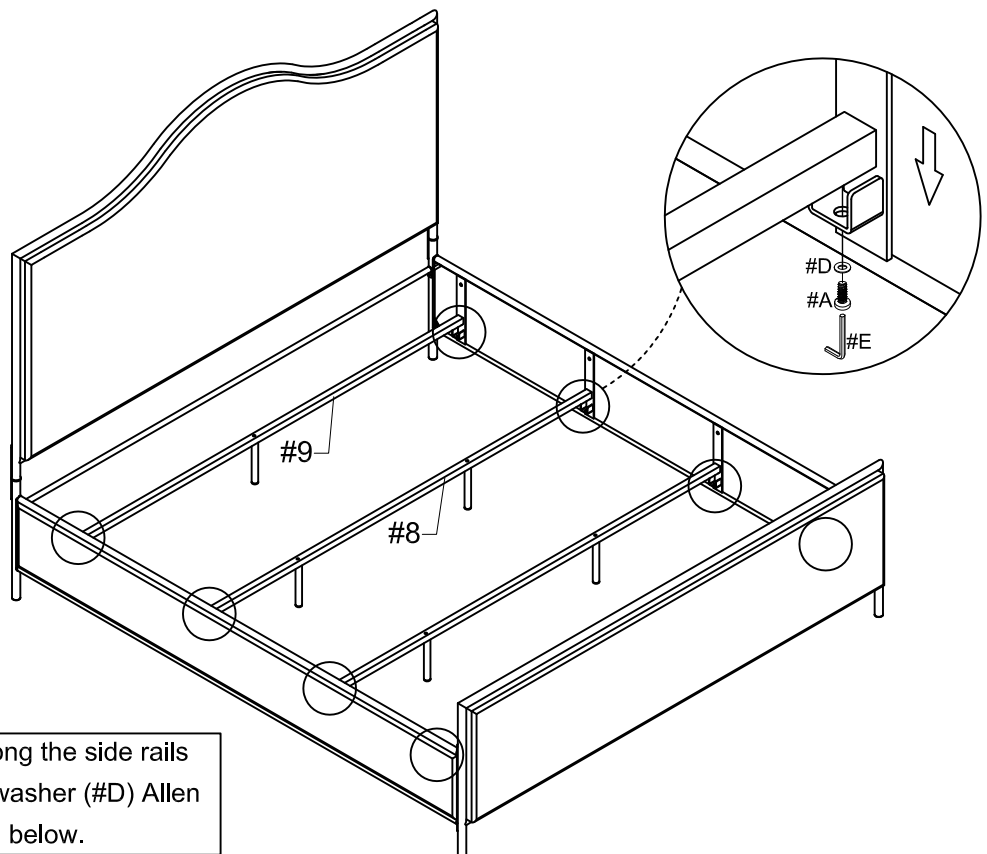

Place the slats onto the slots along the side rails then, insert a bolt (#A) with flat washer (#D) Allen wrench (#E) into each hole from below.

ASSEMBLY INSTRUCTIONS

7

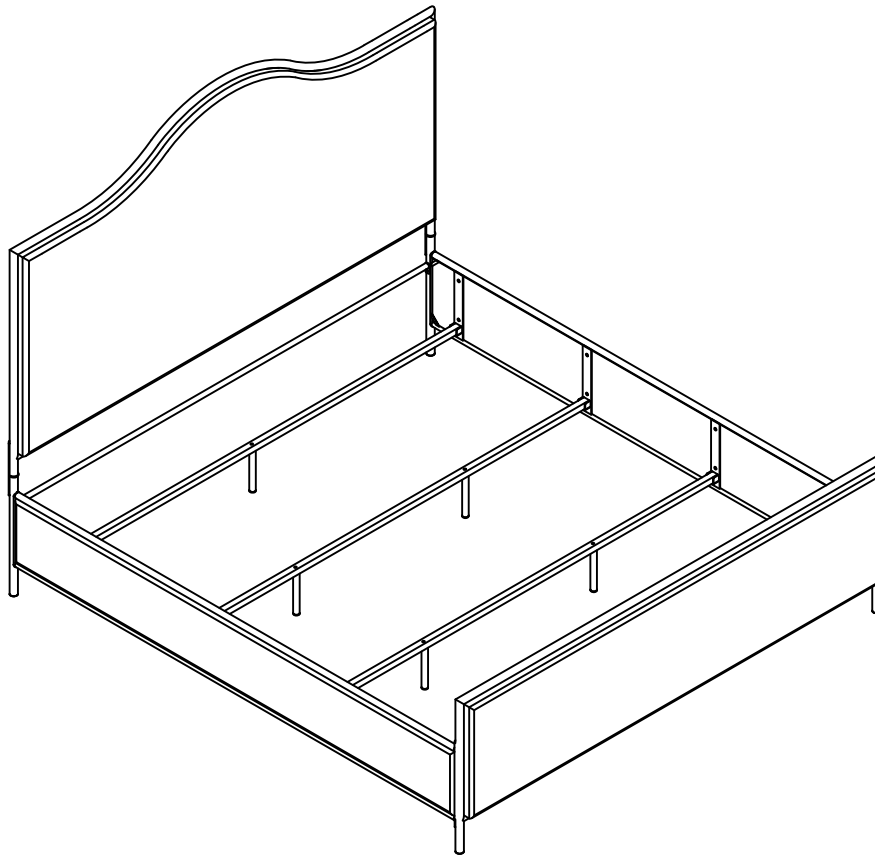

WARNINGS:

- Use only mattress which is 79"-80" long and 75"-76" wide. (ITEM NO:FM77001GD-EK-3A/FM77001GY-EK-3A).
- Do not allow horseplay or under the bed and prohibit jumping on the bed.
- Periodically check and ensure that all the components are in their proper position, free from damage, and that all connectors are tight.
- Do not use substitute parts, Contact the store for replacement part.
- Maximum total weight is not to exceed 600 lbs.
- **Keep these instructions for future reference.**

ASSEMBLY COMPLETED



Please ensure the furniture rests on an even and flat surface. If the product wobbles or feels loose, double-check all bolts and/or screws are properly tightened and secured.



Keep this handy !

Please retain this instruction manual and any order-related information for future reference.



Lift don't drag !

To avoid damage to product please always LIFT the product when transporting or adjusting the placement.

This product is intended for RESIDENTIAL USE ONLY and not for commercial use.