

---

## ASSEMBLY INSTRUCTION

# OFFICE CHAIR



---





Please carefully unpack and identify each component before beginning assembly. Before you begin, please refer to parts list to make sure that you have all parts. Please take care when assembling the unit and always place the parts on a clean, soft surface. If you require assistance with assembly or parts, please call 888-357-7263.

---



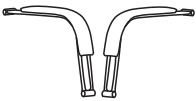
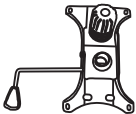

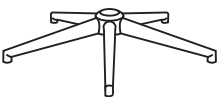
## PRE-ASSEMBLY PREPARATION

- **CAUTION:** Assembly will require at least 2 adults. DO NOT use power tools. Please inspect all items BEFORE assembly. If for any reason you need to return this item, please kindly return it in it's original packaging.
- **WARNING!**
  1. DO NOT let any sharp objects touch or rub the surface of the product.
  2. When assembling, do not let children play around the working area.
  3. DO NOT tighten all bolts and screws completely until the entire unit has been assembled and set up.
  4. DO NOT USE if this product become damaged, and/or components are broken or missing.
- **CARE AND CLEANING:** DO NOT scratch or chip the finish. DO NOT use abrasive chemicals for cleaning. Clean with mild soap on a soft rag. Rinse and dry thoroughly.
- **MAINTENANCE:** Please periodically check all fittings and re-tighten as necessary.

### PARTS LIST

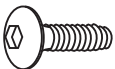
Cushion (A)  Qty: 1	Arm Rest (B)  Qty: 2	Seat Plate(C)  Qty: 1	Gas Lift (D)  Qty: 1
Base (E)  Qty: 1	Wheel (F)  Qty: 5		

### HARDWARE LIST

Allen Bolt (G) M6X20mm  Qty: 4	Allen Bolt (H) M8X40mm  Qty: 4	Cover Caps (I)  Qty: 4	Allen Wrench (J) M6  Qty: 1
--	--	--	---

## STEP-BY-STEP ASSEMBLY

PLEASE CAREFULLY UNPACK AND IDENTIFY EACH COMPONENT BEFORE BEGINNING ASSEMBLY. BEFORE YOU BEGIN, PLEASE REFER TO PARTS LIST TO MAKE SURE THAT YOU HAVE ALL PARTS.

**STEP 1** Insert the Gas Lift (D) to the Five-jaw Base (E), then snap in the Wheels (F) as shown below.

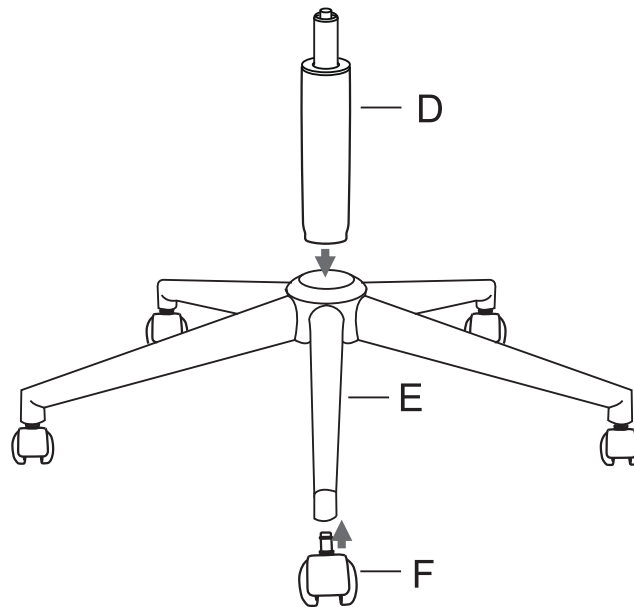

**STEP 2** Attach the Seat Plate (C) to the Cushion (A) by using Allen Bolt (G) and Allen Wrench (J).

**Please 80% tighten the bolts.**

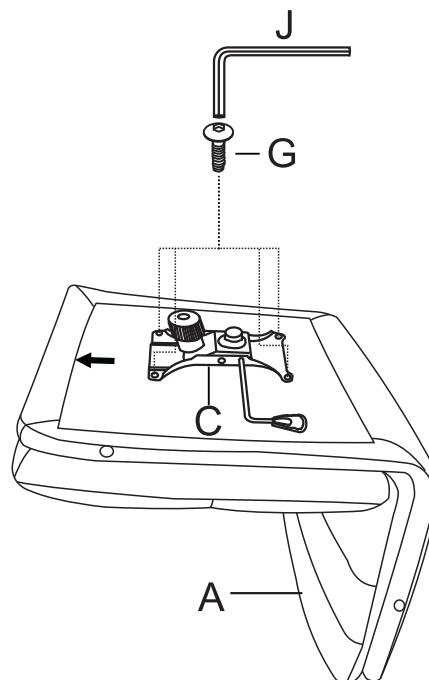

**STEP 3** Attach the Arm Rest(B) to the side of Cushion(A) using Allen Bolt (H) and Allen Wrench (J).

**The left and right armrests have labels to distinguish them. Please be careful not to mix them up.**

**Please 80% tighten the bolts.**

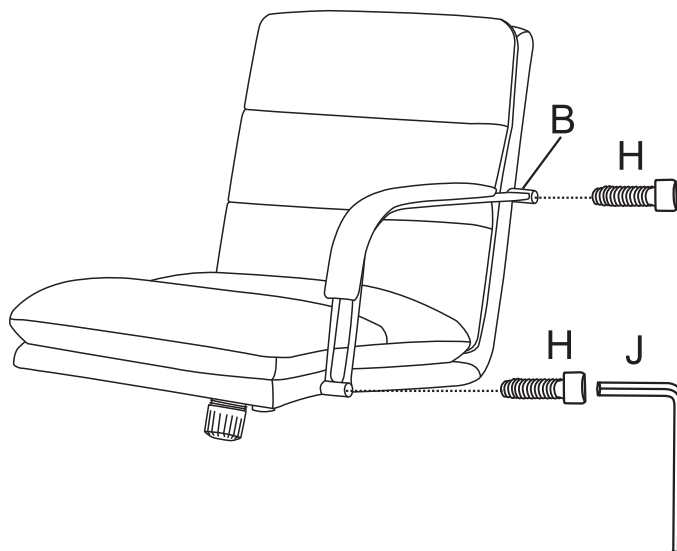

**STEP 4** Cover the side screw holes with Cover Caps(I).

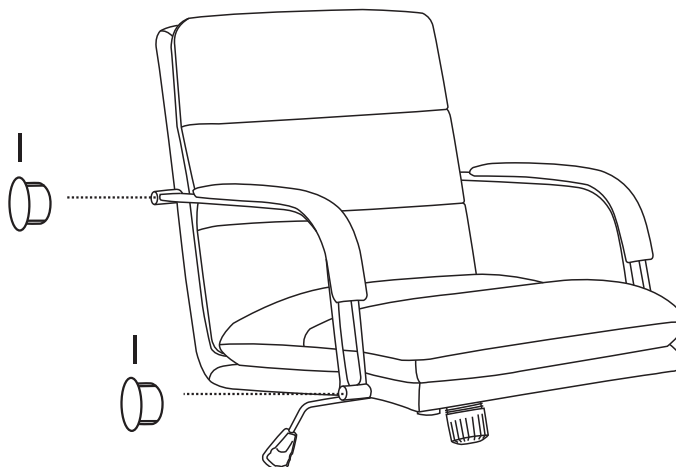

**STEP 5** Insert the Gas Lift (D) to the Seat Plate (C) as shown in below diagram.

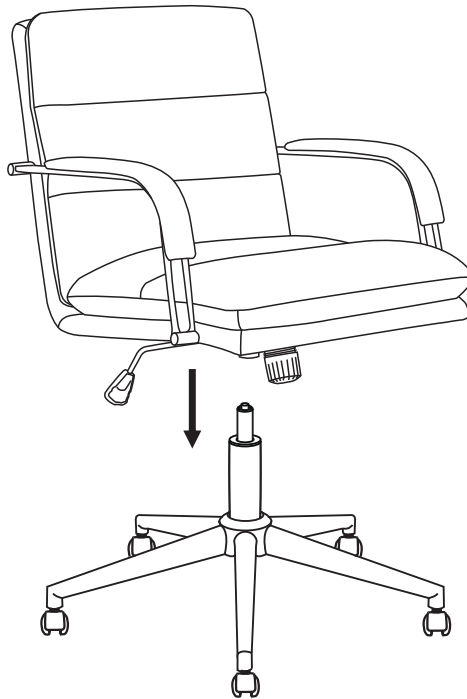

**STEP 6** In this step please make sure the chair is flat and all bolts are installed, then finally 100% tighten all bolts.

A few days after initial assembly, the product may acclimate to its new environment.

**Please ensure all screws are still securely tightened.**

