

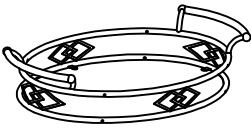

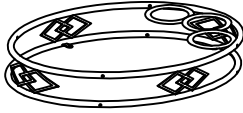

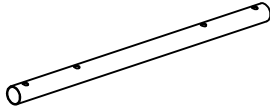



ASSEMBLY INSTRUCTION

GOLDEN FINISH BLACK TEMPERED GLASS METAL KITCHEN CART

A Top frame	B Bottom ring	C Leg	D Glass
			
1 pc	1 pc	4 pcs	2 pcs
E Suction cup	F Allen wrench	G Open end wrench	H Bolt
			
8 pcs	1 pc	1 pc	16 pcs
I Washer	J Wheel	K Finial	
			
4 pcs	4 pcs	4 pcs	

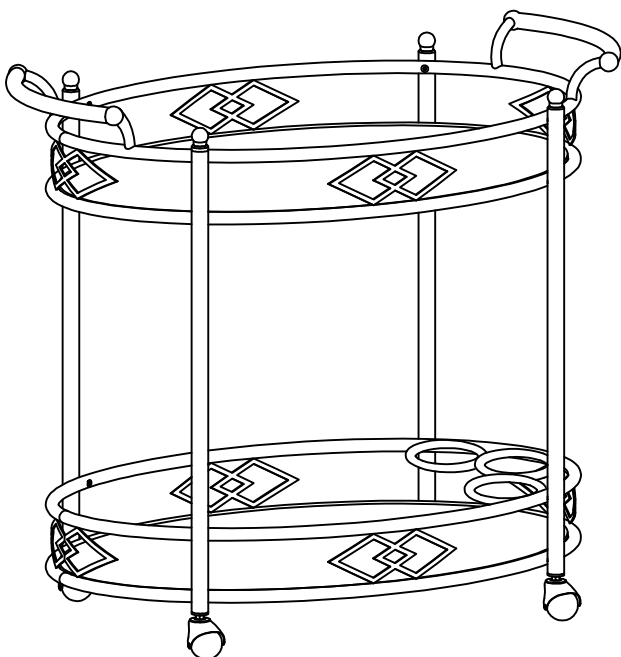

This page lists all the contents included in the box. Please take the time to identify the hardware as well as the individual components to this product. As you unpack and prepare for assembly, place the contents on a carpeted or padded area to protect them from damage.

1

Assemble top frame (A) and bottom ring (B) to leg (C) with bolt (H) as shown in drawing and tighten with the Allen wrench (F).

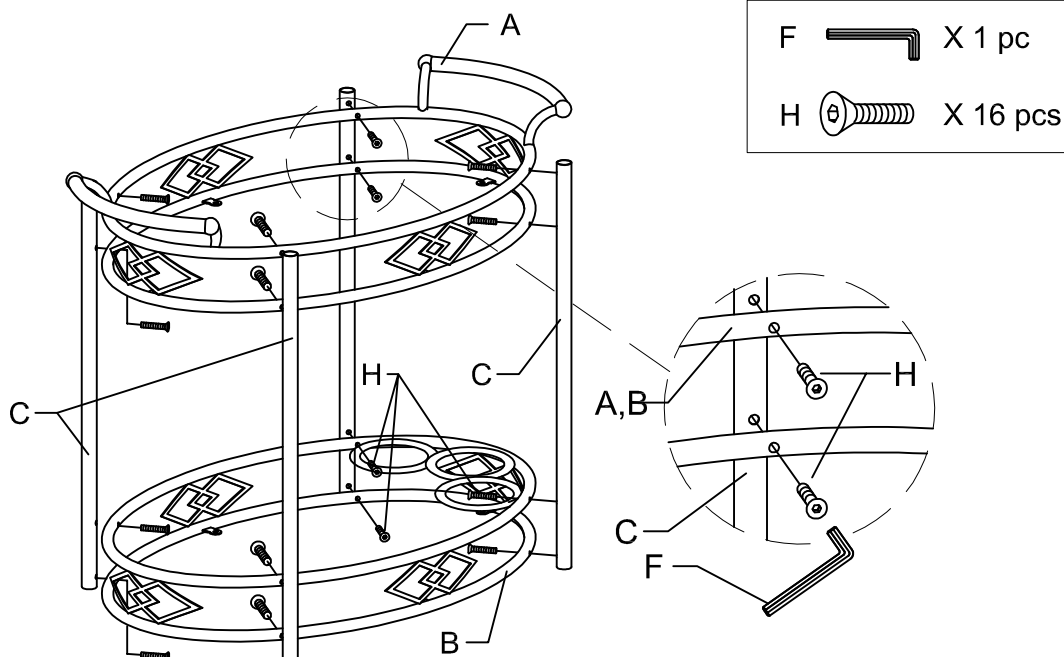
**2**

Install finial (K) on the tube end of leg (C) as shown in drawing and put suction cups (E) into the ear tabs of top frame (A) and bottom ring (B). Then install wheel (J) into the tube end of leg (C) with washer (I) and tighten it up by use of open end wrench (G).

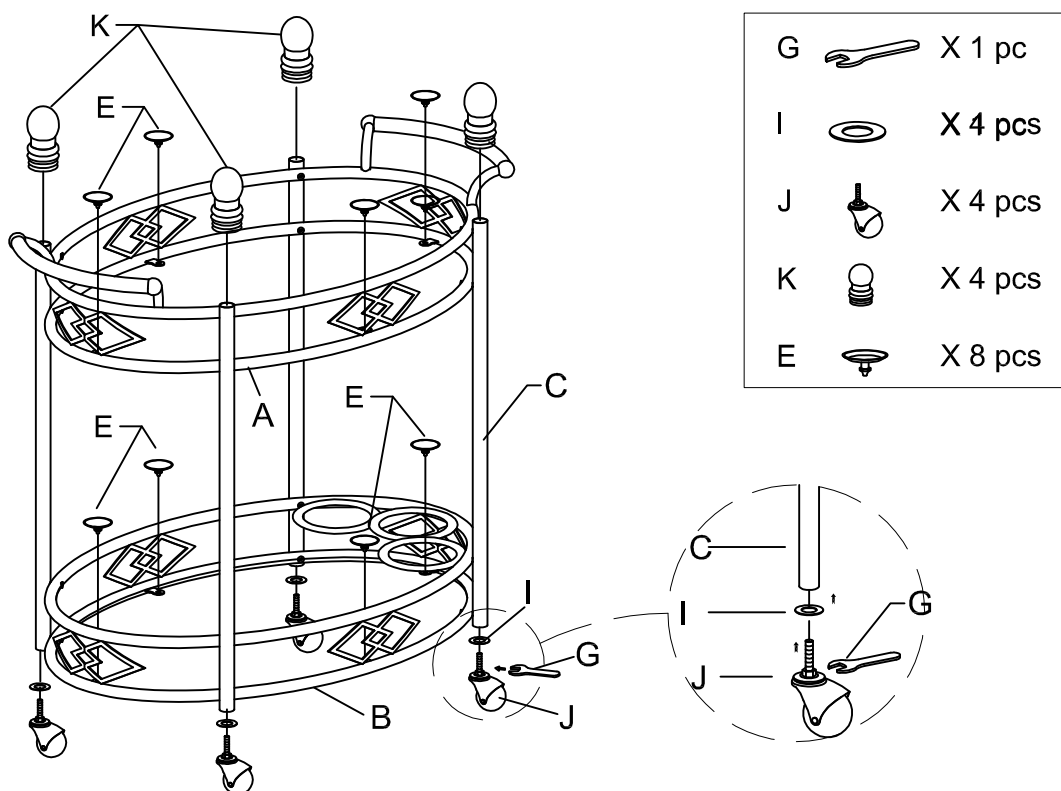

3

Place glass (D) on top frame (A) and bottom ring (B) respectively.

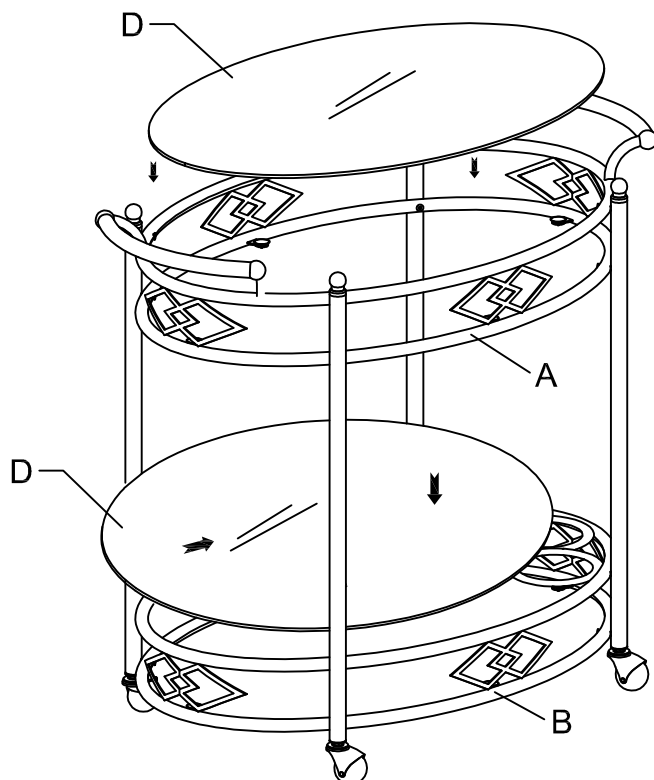

Cleaning & Care

Treat surface with care. Surface is resistant to scratches but is not scratch resistant. Clean surfaces with a dry or damp soft cloth. Do not use abrasive cleaners. Hardware may loosen over time. Periodically check that all connections are tight.