

# ASSEMBLY INSTRUCTION

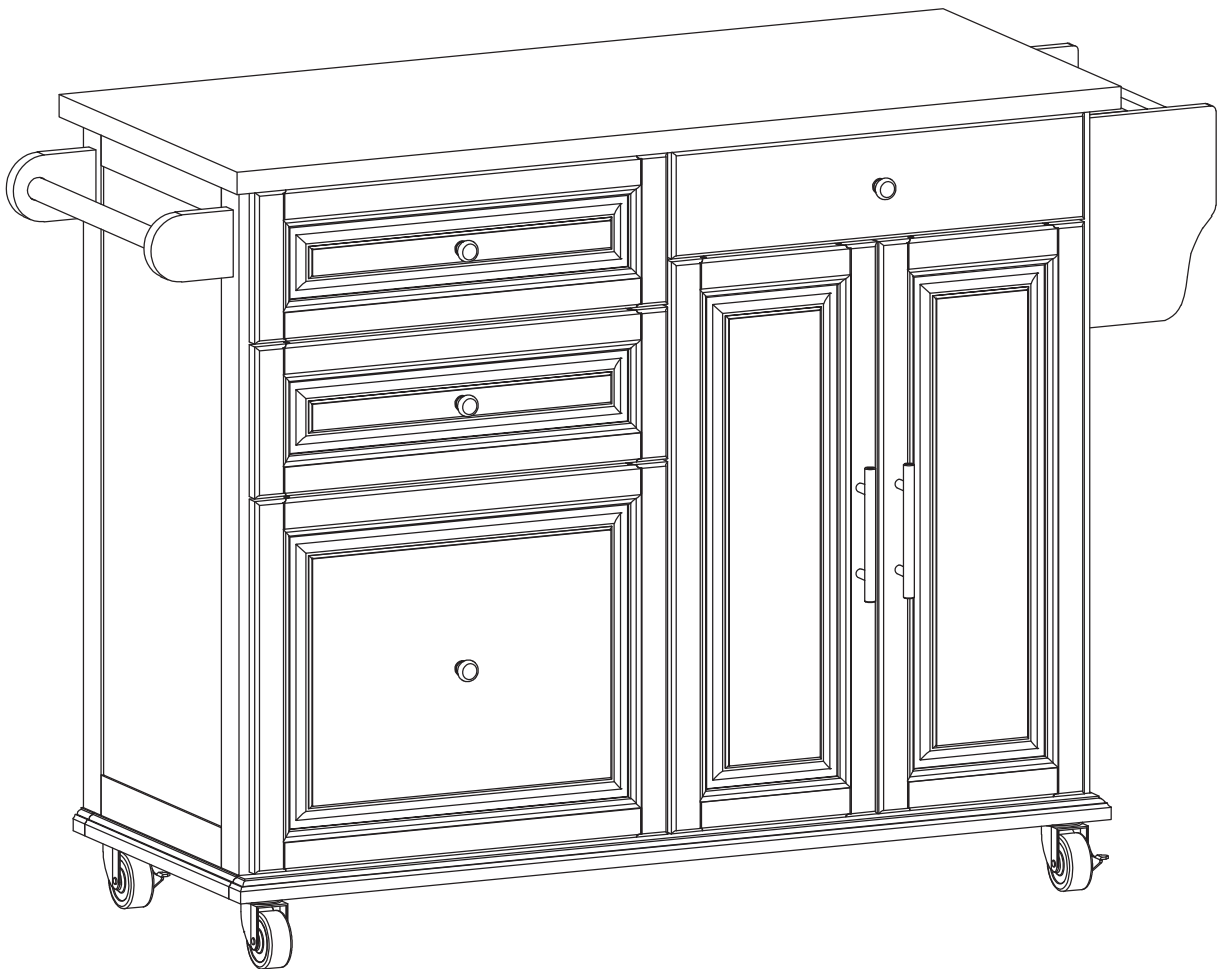























**N775P396853**

**IMPORTANT NOTE:**

1. Place all parts on a clean and smooth surface such as a rug or carpet to avoid the parts from being scratched.
2. Before you begin, kindly follow the assembly instruction step by step.
3. Do not tighten all screws and bolts until the bar cart is fully set-up.
4. Please do not return to store, contact the seller if you have any troubles with this product.

## Caution : You must read this before you proceed

### Care & Maintenance

-   ● Not for commercial use. For residential use only.
  -   ● Furniture may scratch floors. We recommend using furniture pads to protect your floors.
  -   ● Do not put hot items directly on furniture surface.
  -   ● Do not clean furniture with harsh cleansers or polish.
  -   ● Do not place furniture under direct sunlight.
  -   ● Do not place furniture near heating or cooling vents.
  -   ● Do not write on furniture without a padded barrier to protect the surface.
  -   ● Do not place furniture outside . For indoor use only.
  -   ● Stains may be removed with mild soap solution and damp cloth.
  -   ● Children should not climb or jump on the furniture.
-   ● Dust and pick-up spills using a clean, non-colored, lint-free cloth.

Please look in carton for hardware packs and legs.

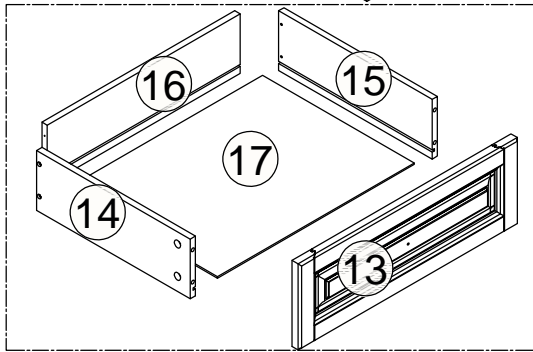
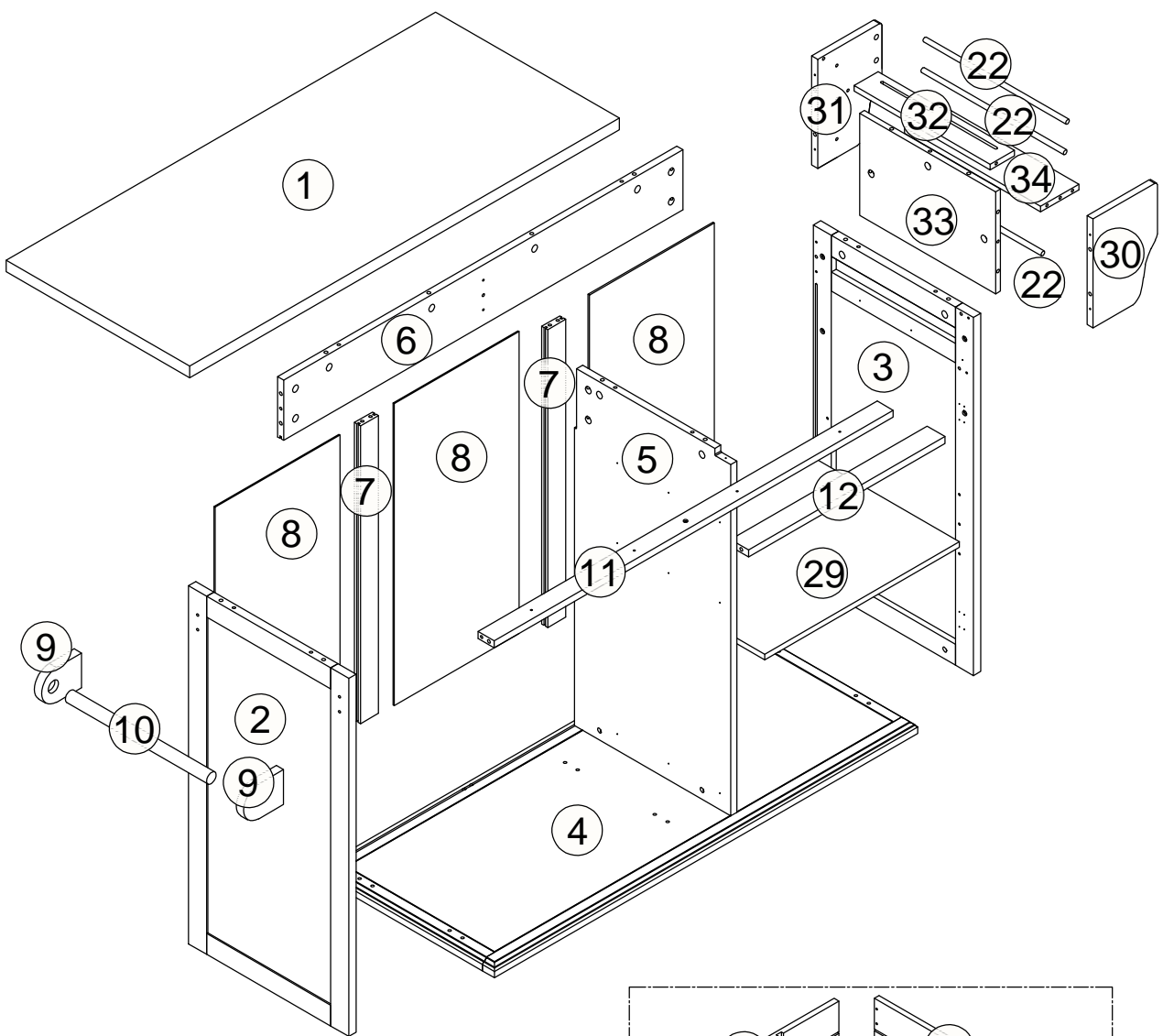

x2

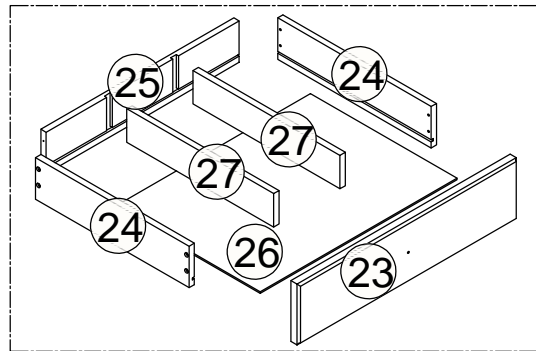

x1

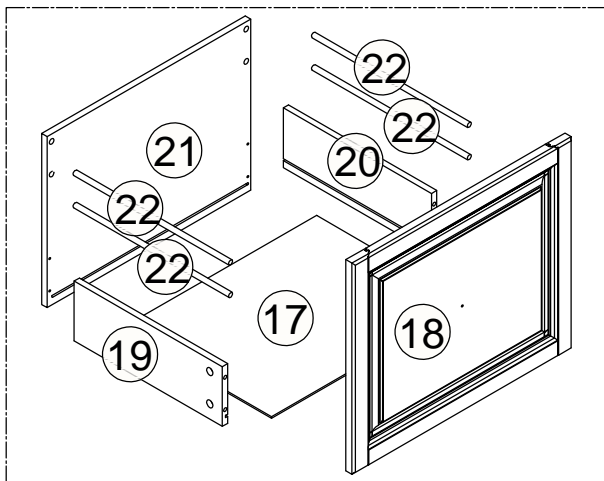

x1

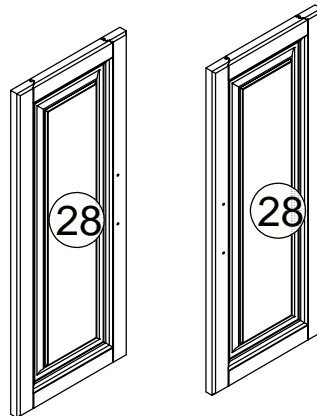

# Part List

① x 1

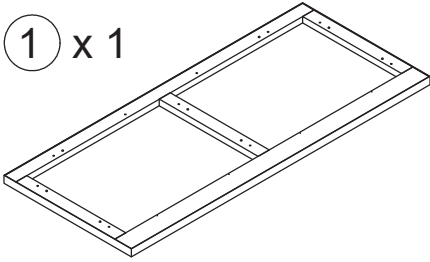

② x 1

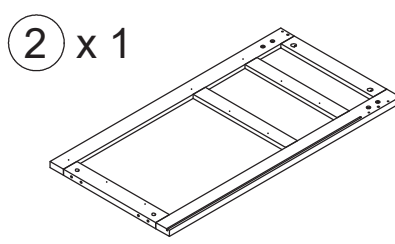

③ x 1

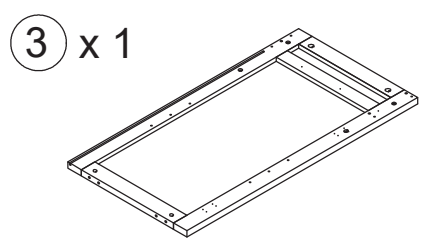

④ x 1

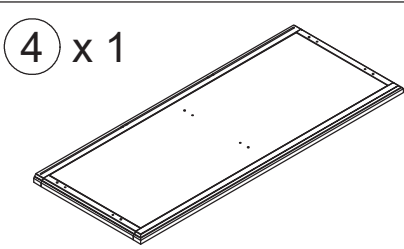

⑤ x 1

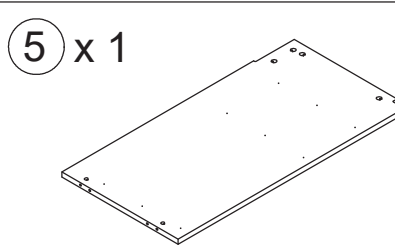

⑥ x 1

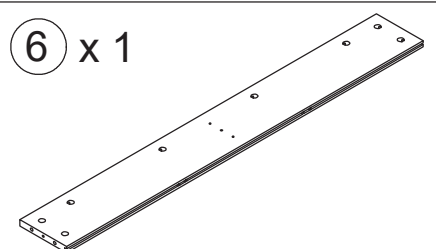

⑦ x 2

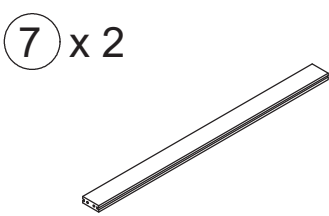

⑧ x 3

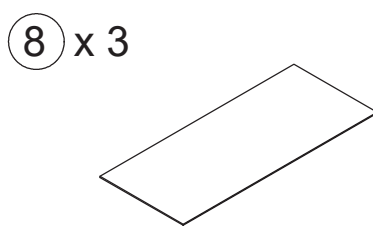

⑨ x 2

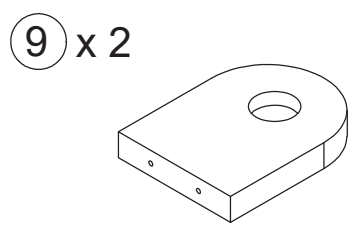

⑩ x 1

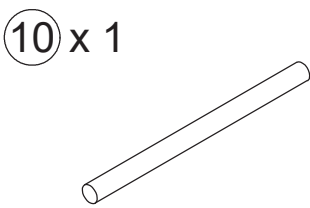

⑪ x 1

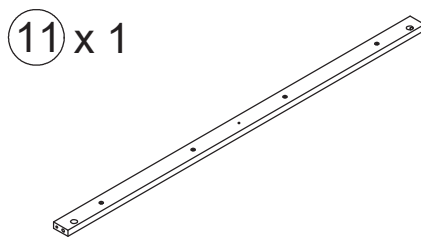

⑫ x 1

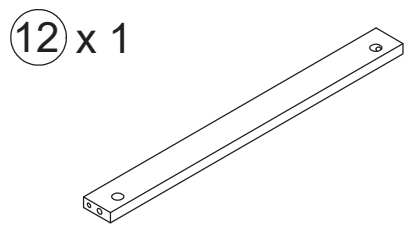

⑬ x 2

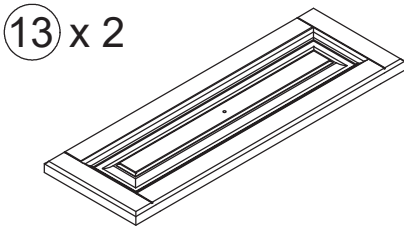

⑭ x 2



⑮ x 2

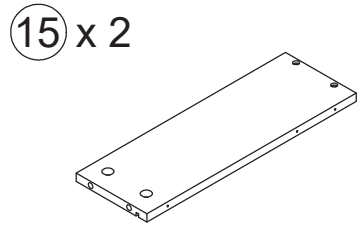

⑯ x 2

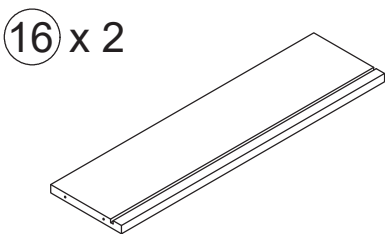

⑰ x 3

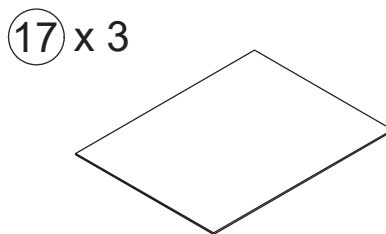

⑱ x 1

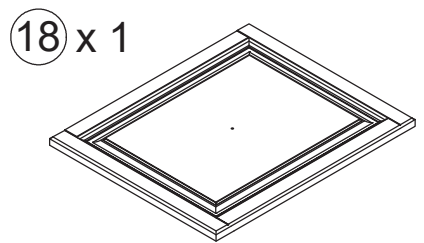

⑲ x 1

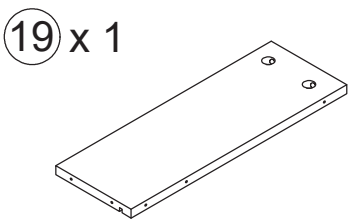

⑳ x 1

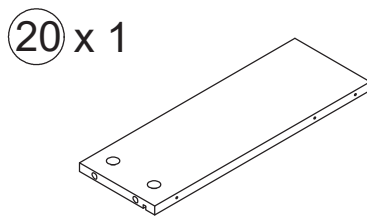

㉑ x 1

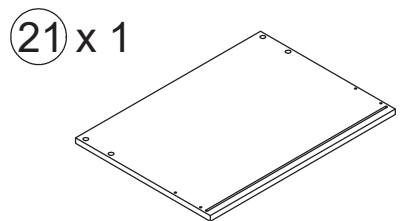

# Part List

22 x 7

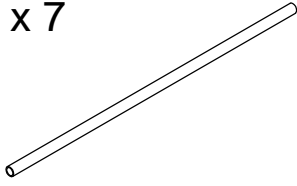

23 x 1

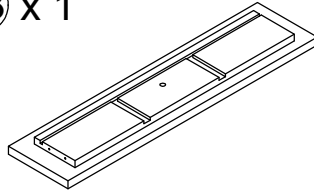

24 x 2

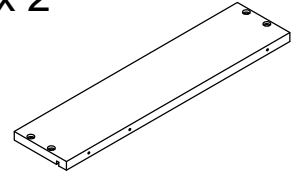

25 x 1

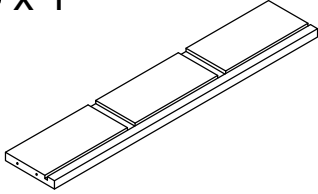

26 x 1

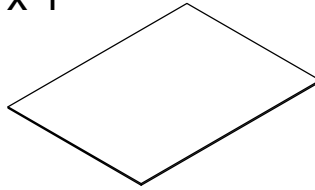

27 x 2

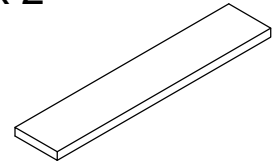

28 x 2

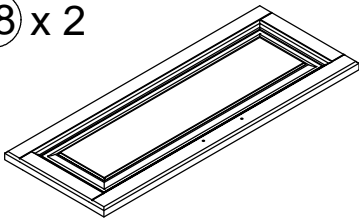

29 x 1

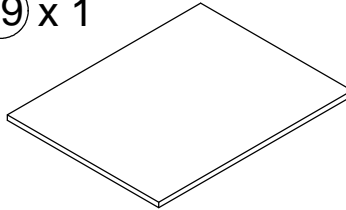

30 x 1

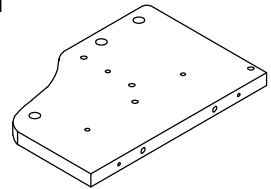

31 x 1

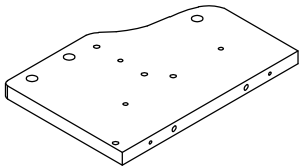

32 x 1

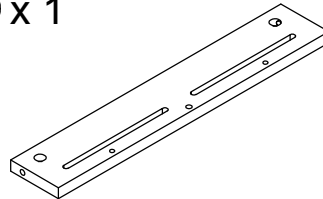



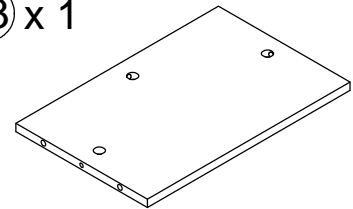



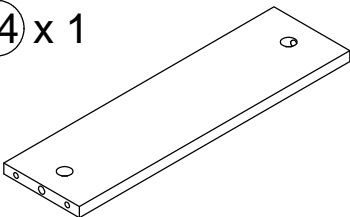

33 x 1

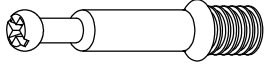

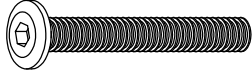
34 x 1

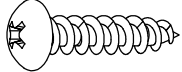

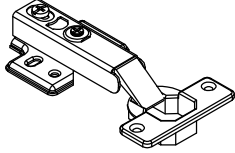
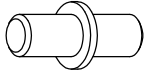
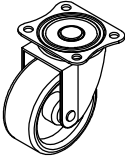
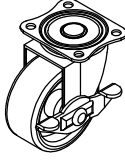
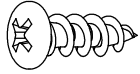
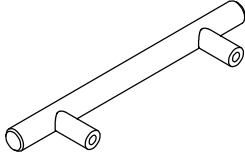
# Hardware List

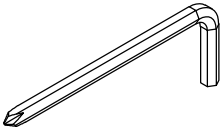
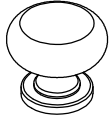
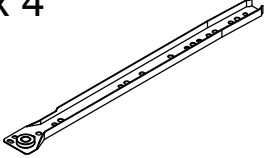
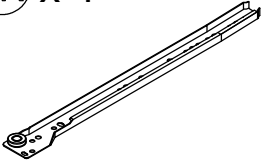
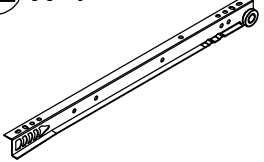
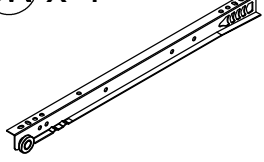
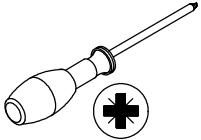
<p>(A) x (39+2)</p>  <p>M6*35mm</p>	<p>(B) x (39+2)</p>  <p>Ø15*9mm</p>	<p>(C) x (43+2)</p>  <p>Ø6*30mm</p>	
<p>(D) x (6+1)</p>  <p>M6*45mm</p>	<p>(E) x (6+1)</p>  <p>Ø10*13mm</p>	<p>(F) x (8+1)</p>  <p>M5*45mm</p>	
<p>(G) x (25+2)</p>  <p>Ø4*30mm</p>	<p>(H) x (72+3)</p>  <p>Ø4*12mm</p>	<p>(I) x 4</p> 	
<p>(J) x (4+1)</p>  <p>Ø5*17mm</p>	<p>(K) x 2</p> 	<p>(L) x 2</p> 	
<p>(M) x (16+1)</p>  <p>Ø5*16mm</p>	<p>(N) x 2</p> 	<p>(O) x (8+1)</p>  <p>M4*18mm</p>	
<p>(P) x 1</p> 	<p>(Q) x 4</p> 	<p>(CL) x 4</p> 	
<p>(CR) x 4</p> 	<p>(DL) x 4</p> 	<p>(DR) x 4</p> 	 <p>Not Provide</p>

# Step 1

x2

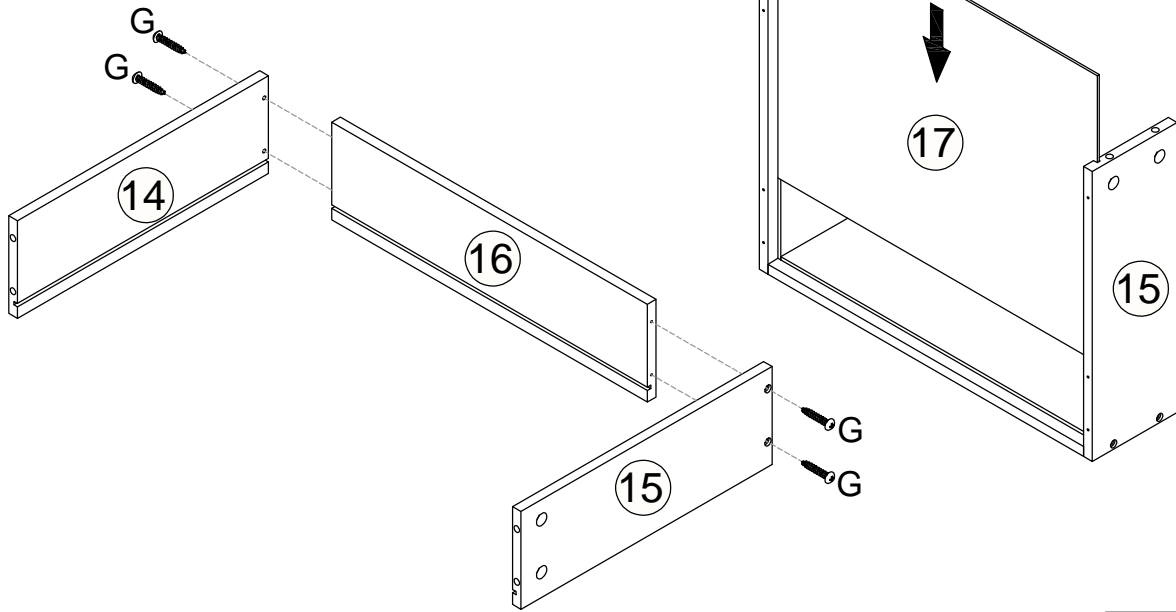

G x 8 PCS



G

# Step 2

x2

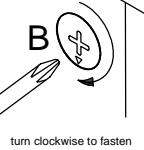
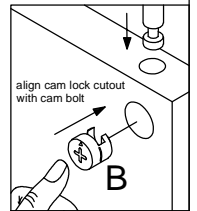
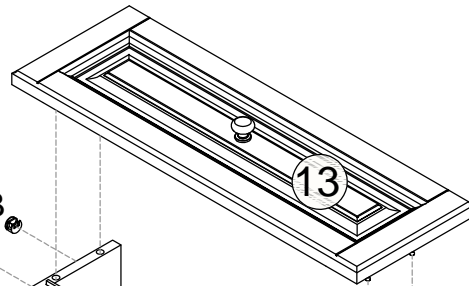
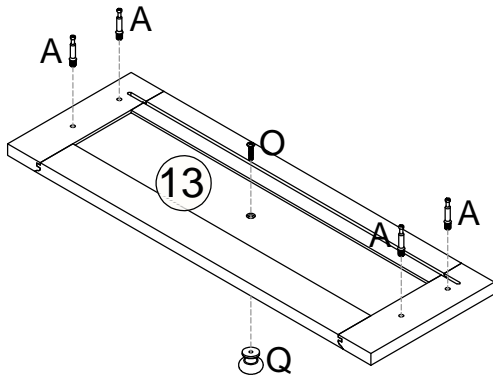
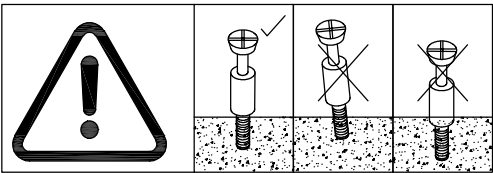

A x 8 PCS

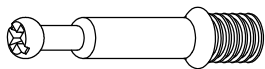

B x 8 PCS



O x 2 PCS

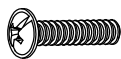

Q x 2 PCS



### Step 3

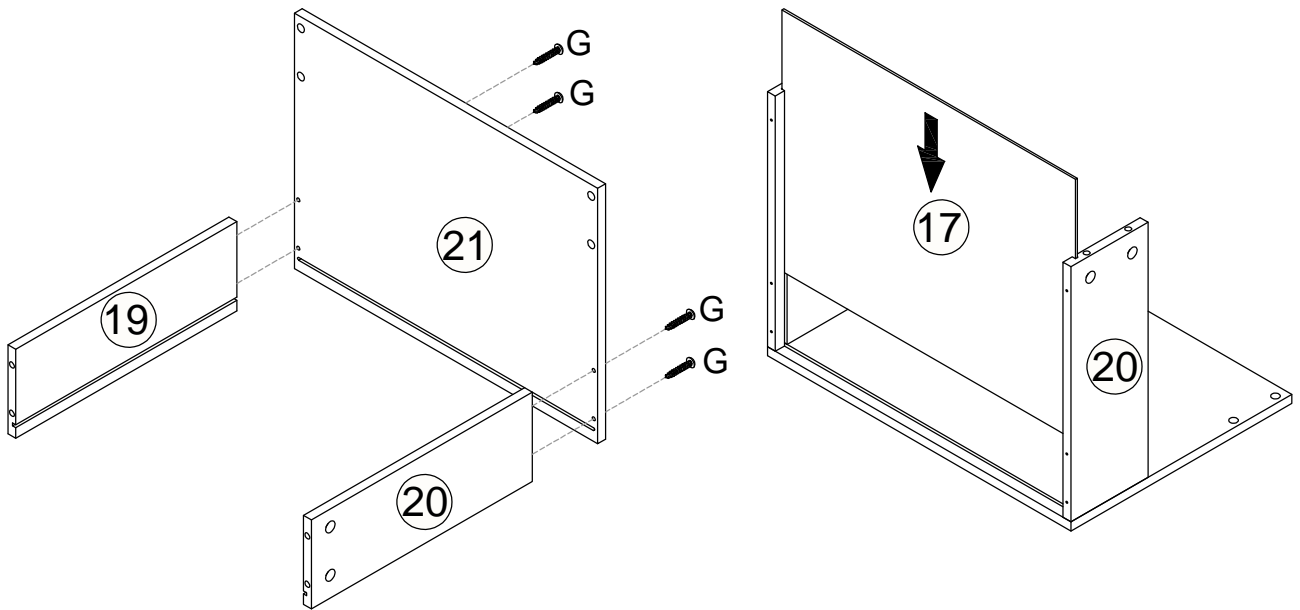

G x 4 PCS

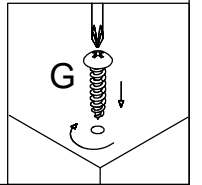
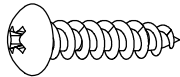

### Step 4

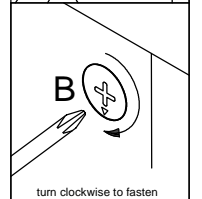
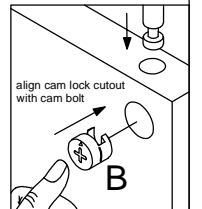
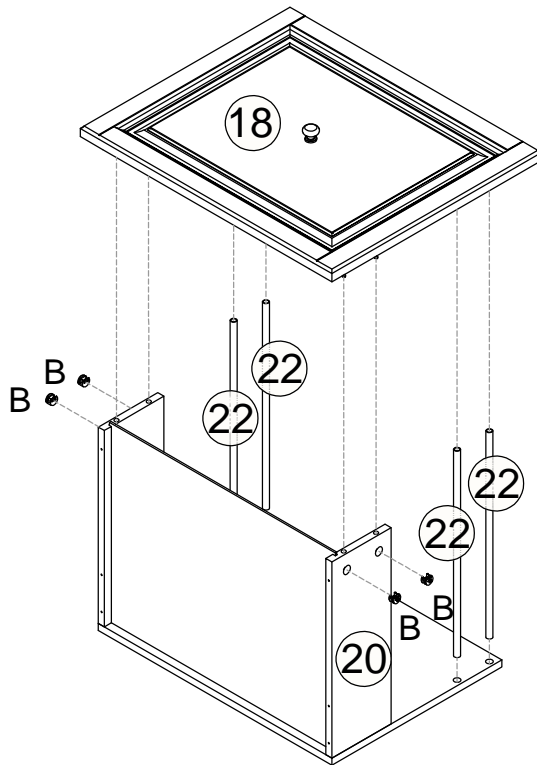
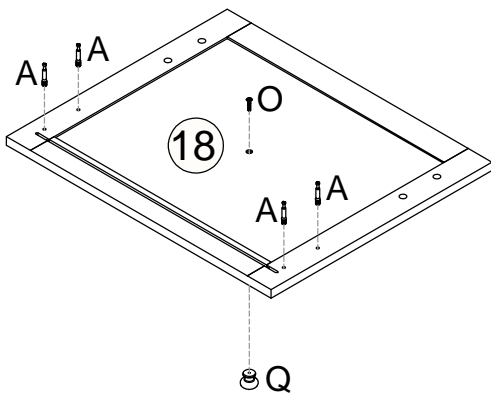
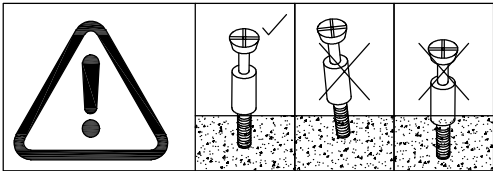

A x 4 PCS

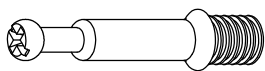

B x 4 PCS



O x 1 PC

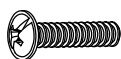

Q x 1 PC



# Step 5

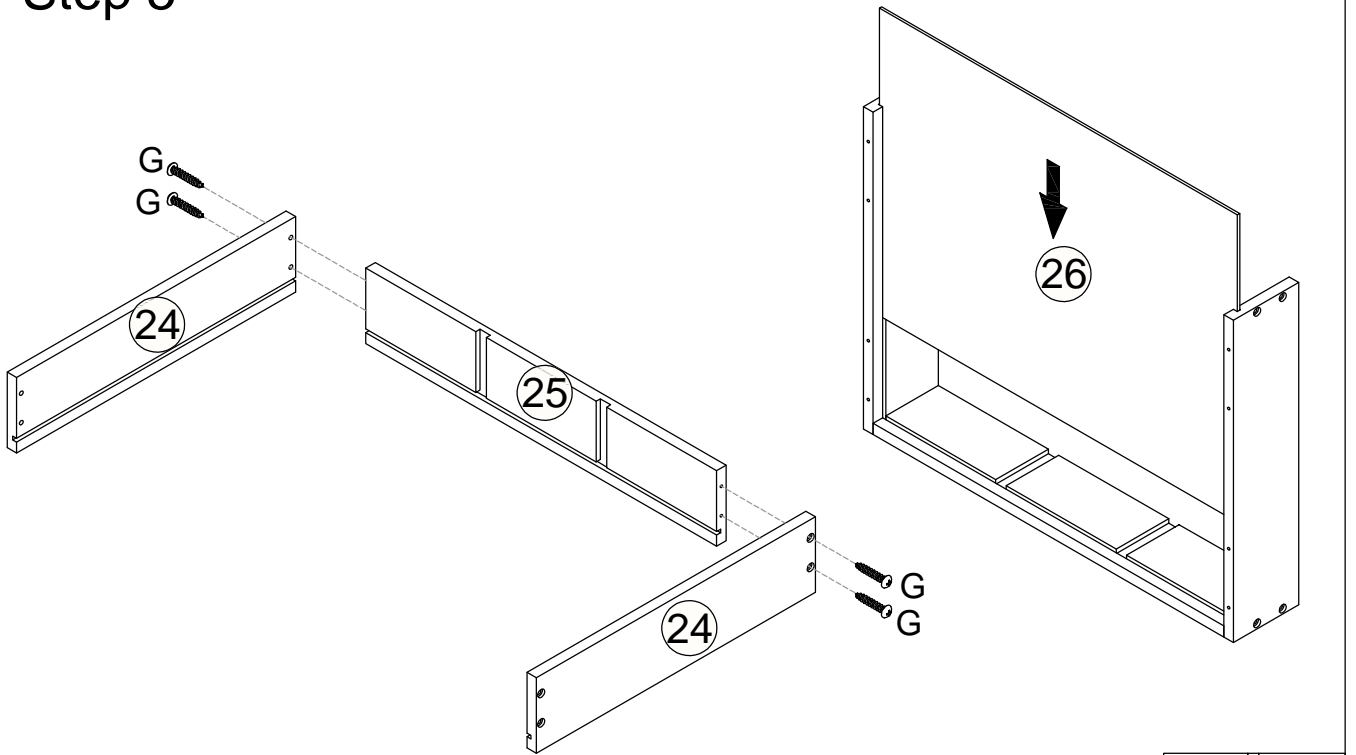

G x 4 PCS

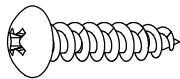

G

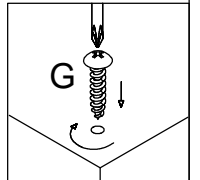

# Step 6

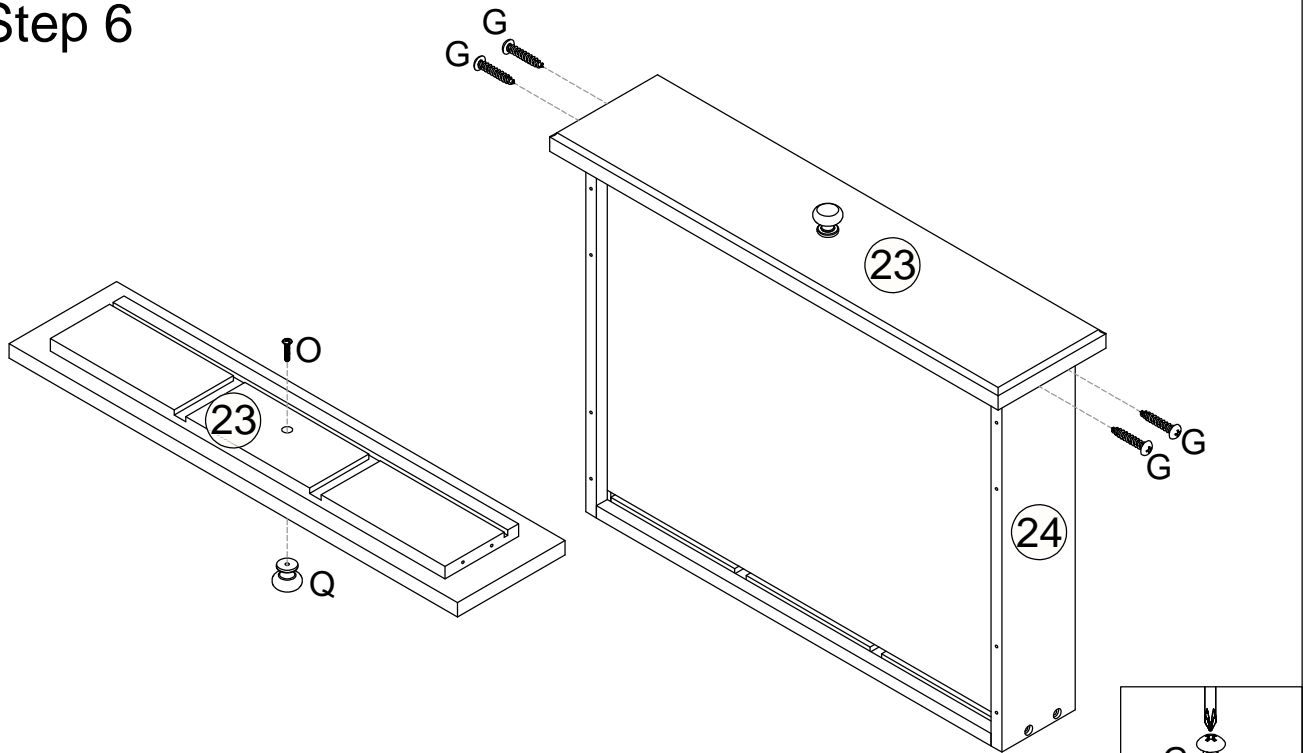

G x 4 PCS

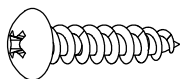

G

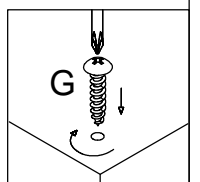

O x 1 PC

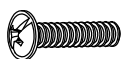

Q x 1 PC



# Step 7

# x2

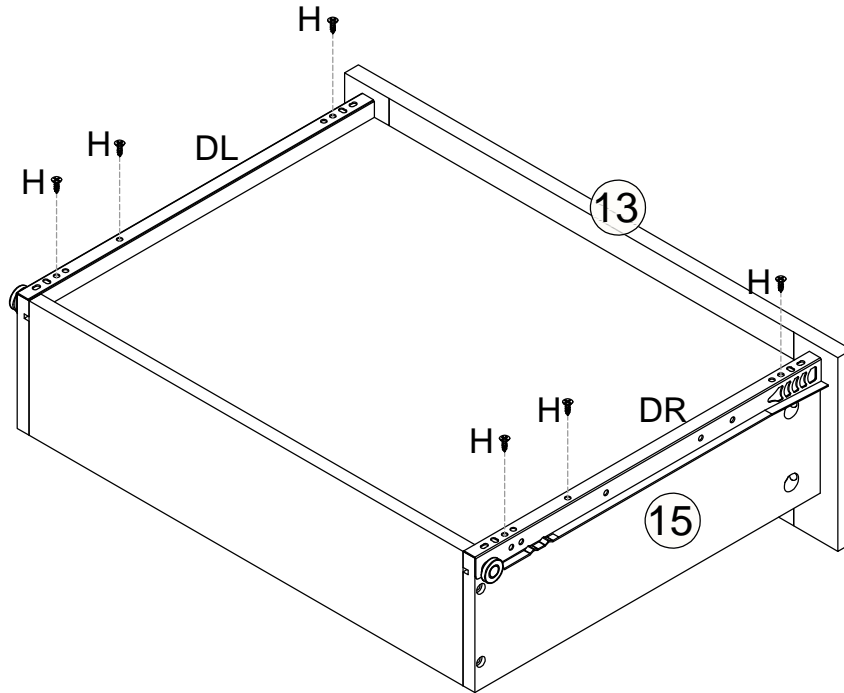

H x 12 PCS



DL x 2 PCS



DR x 2 PCS

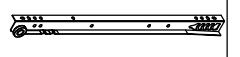

# Step 8

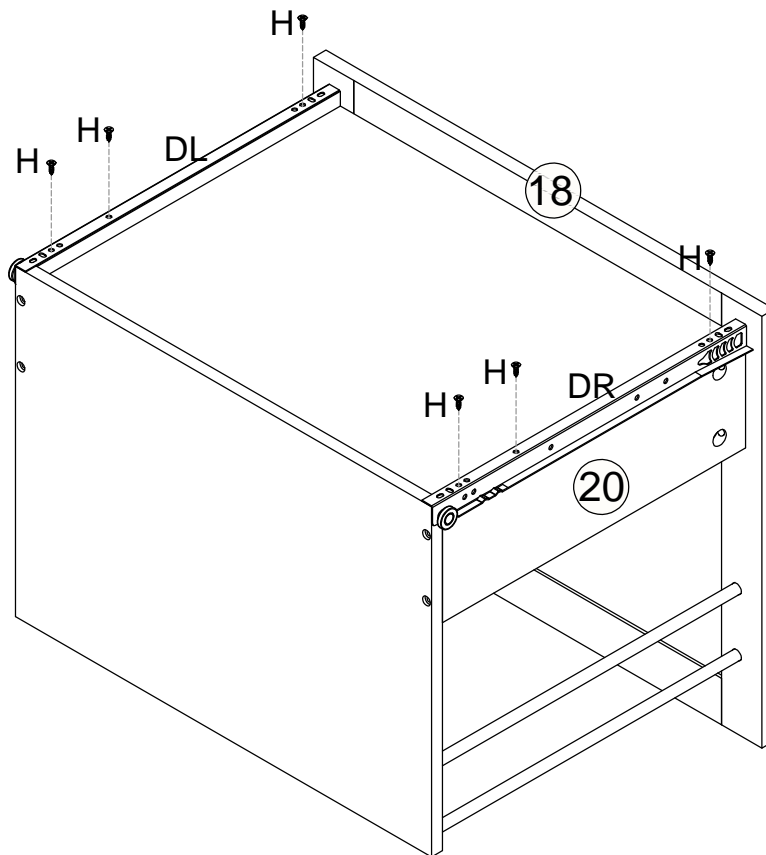

H x 6 PCS



DL x 1 PC



DR x 1 PC



# Step 9

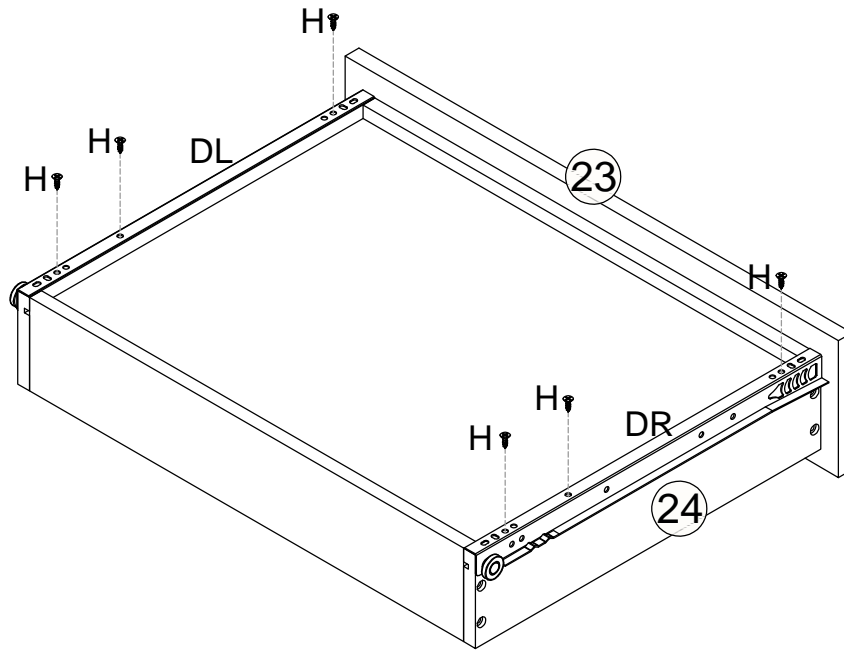

H x 6 PCS



DL x 1 PC

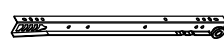

DR x 1 PC

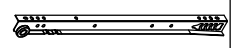

# Step 10

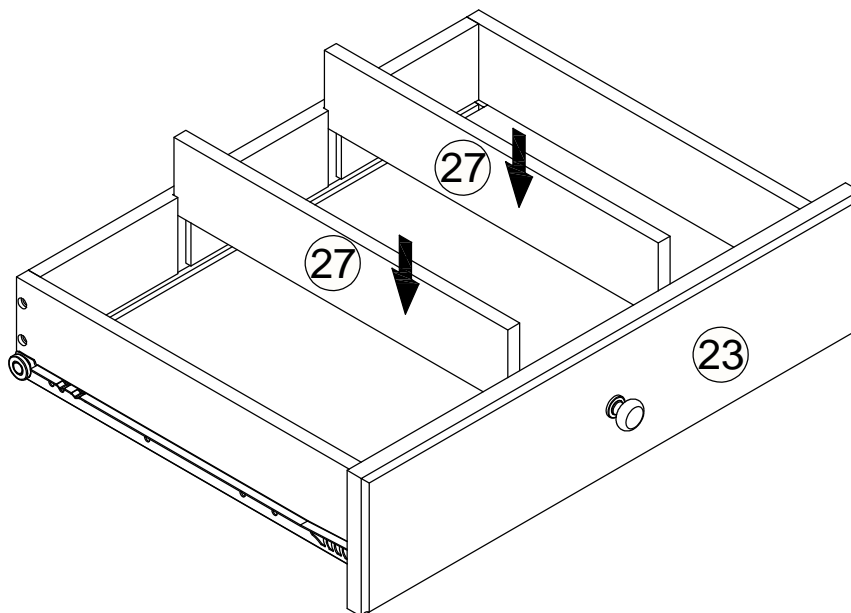

# Step 11

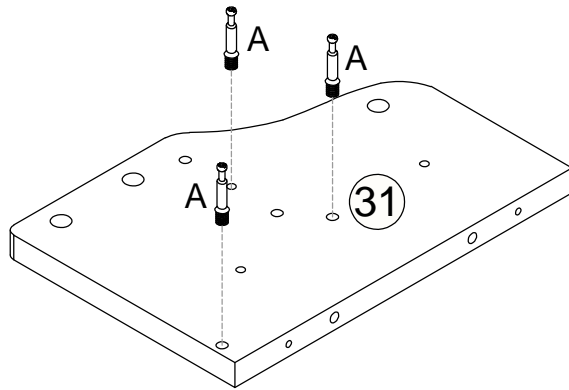
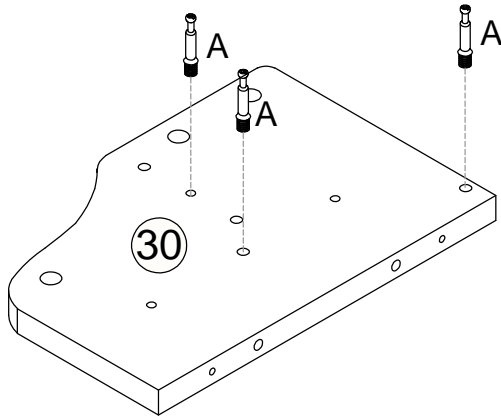
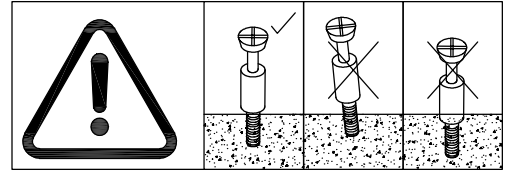

A x 6 PCS

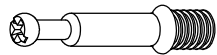

# Step 12

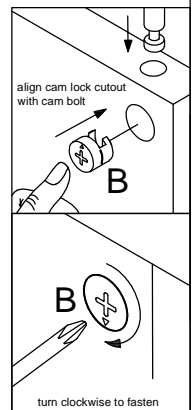
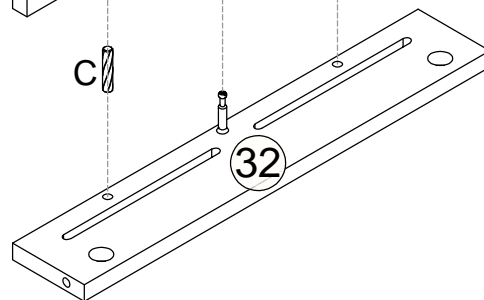
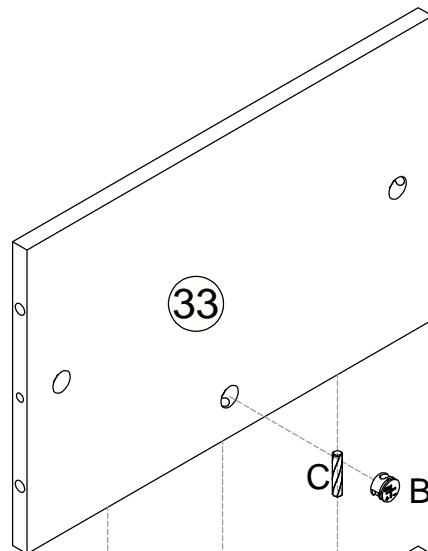
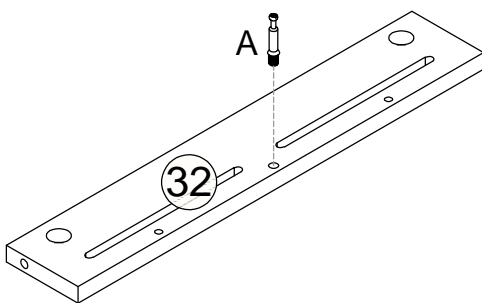
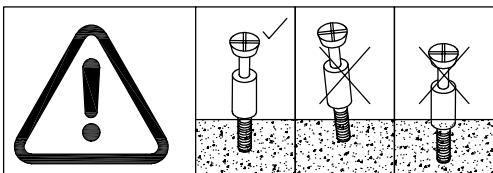

A x 1 PCS

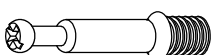

B x 1 PCS



C x 2 PCS



# Step 13

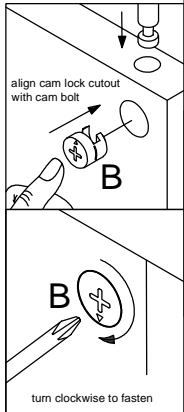
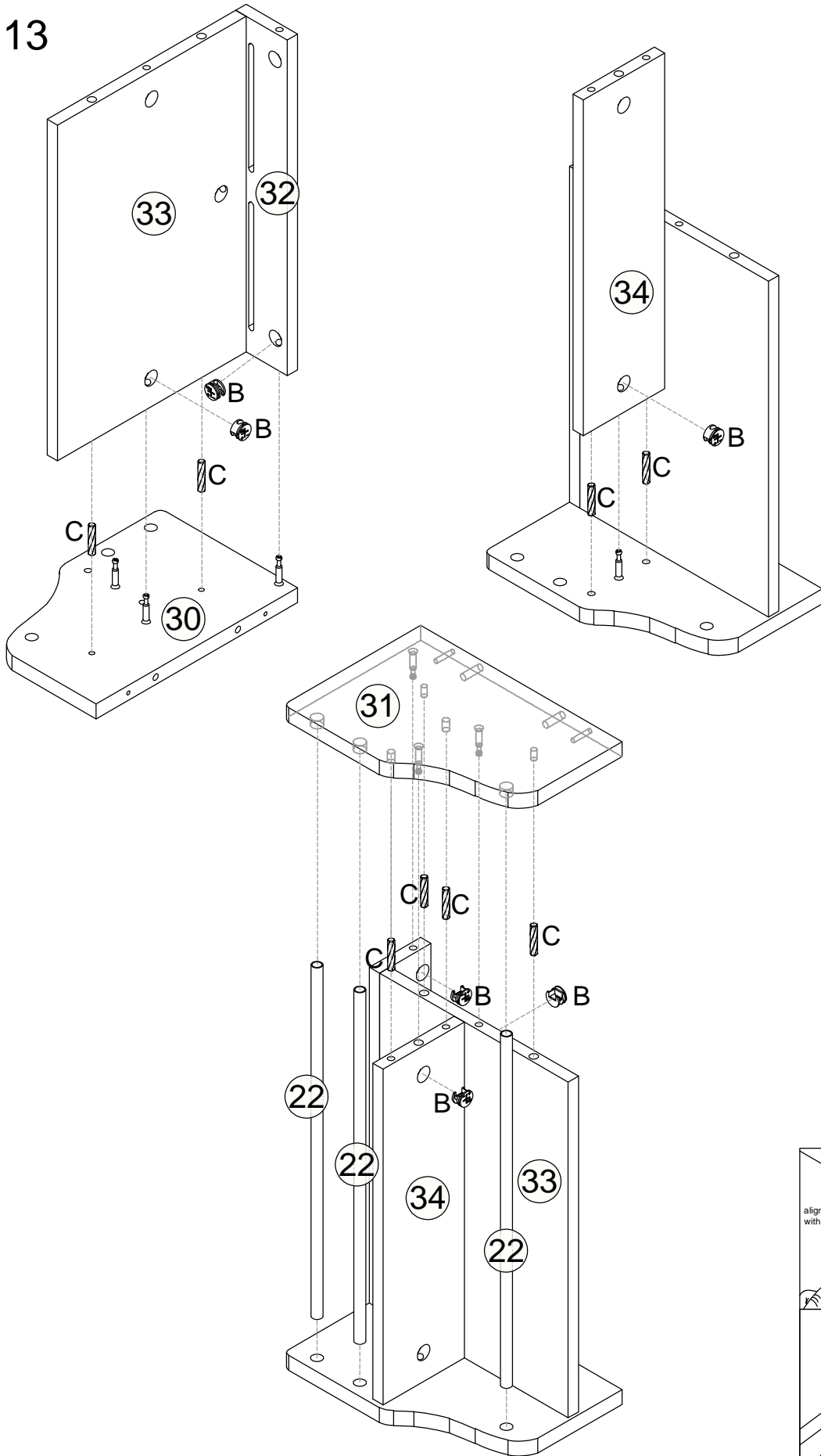

B x 6 PCS



C x 8 PCS



# Step 14

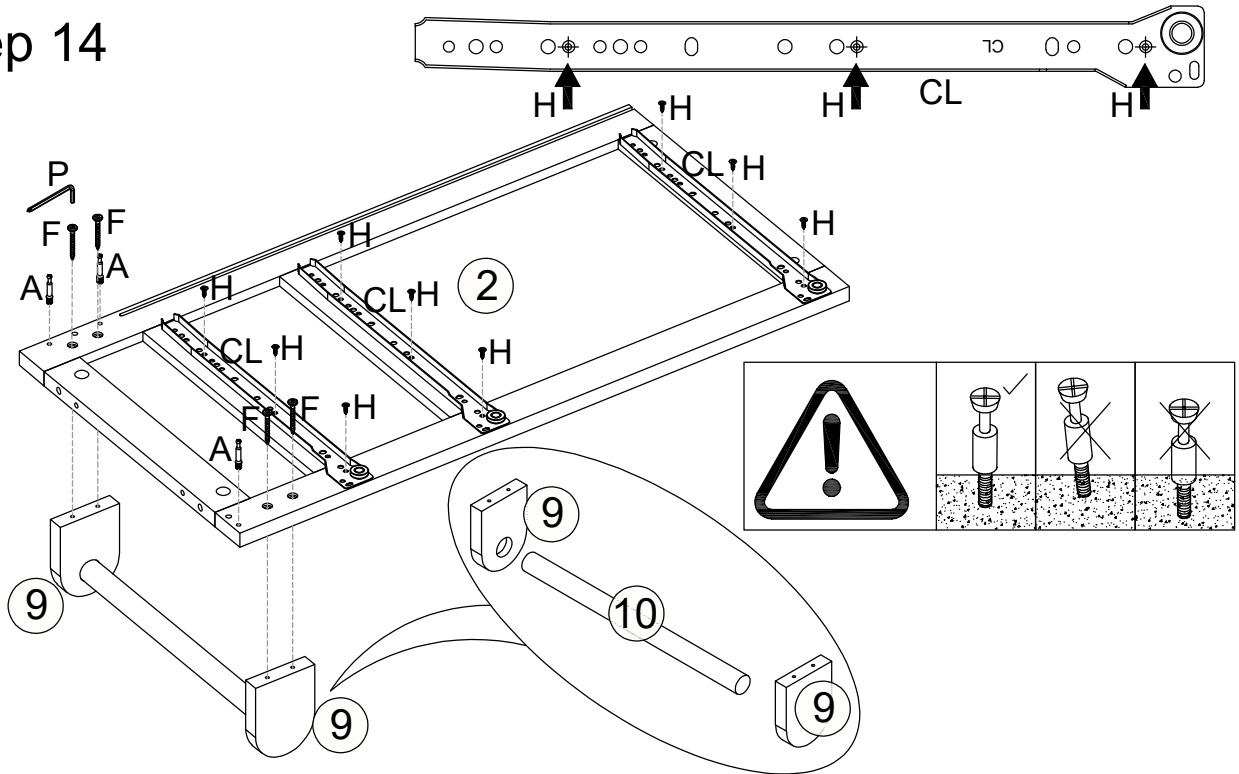

A x 3 PCS		F x 4 PCS	
H x 9 PCS		P x 1 PC	
		CL x 3 PCS	



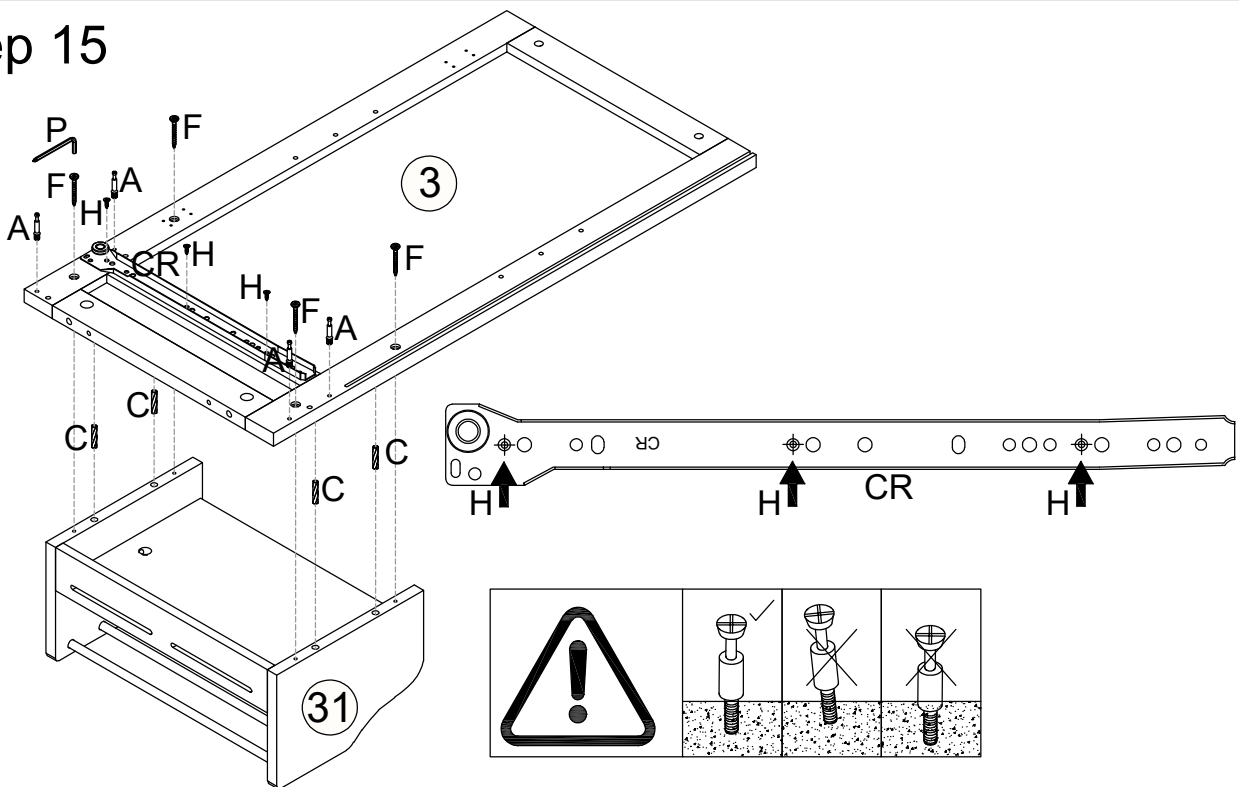

# Step 15

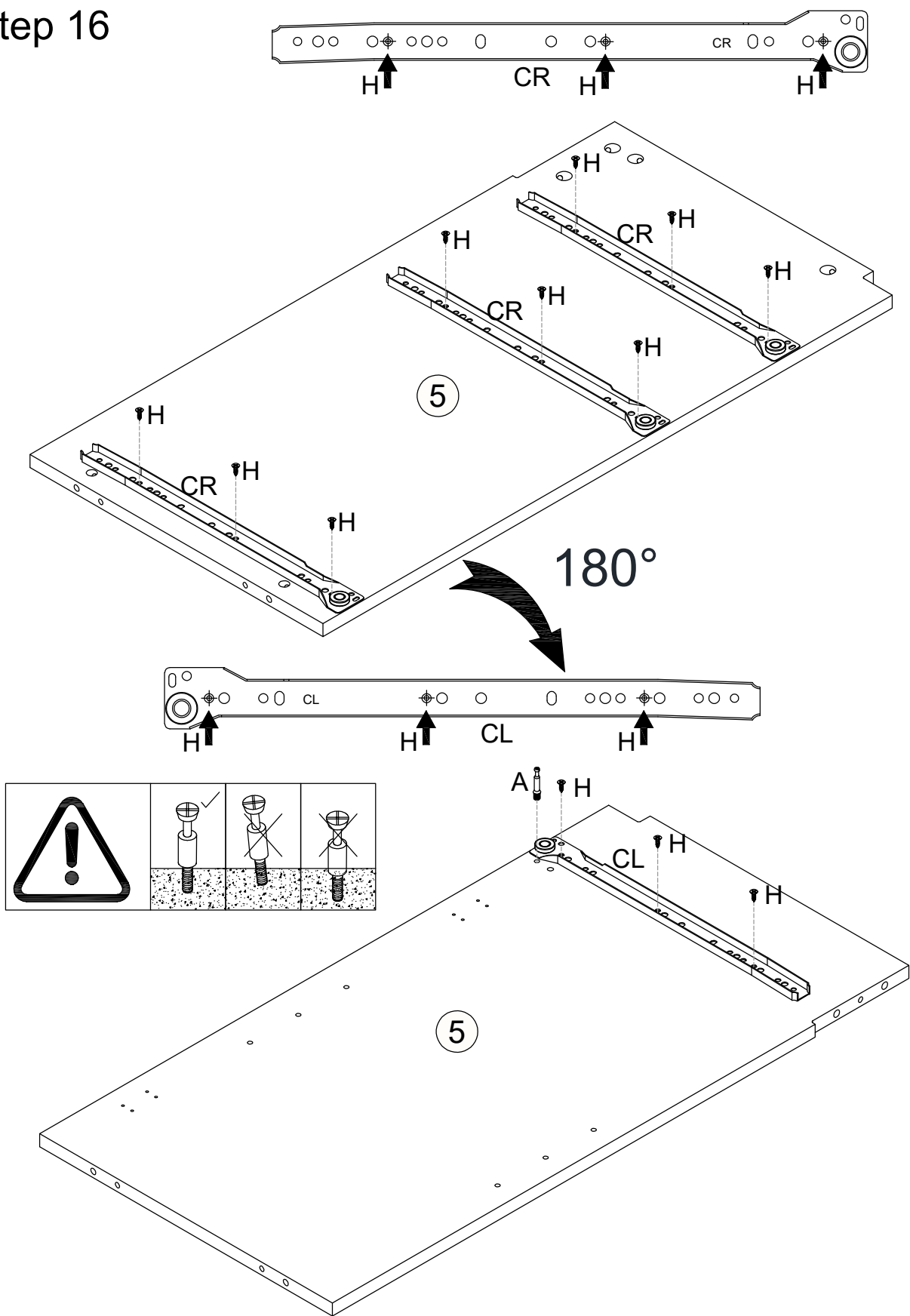

A x 4 PCS		C x 4 PCS		F x 4 PCS	
H x 3 PCS		P x 1 PC		CR x 1 PC	

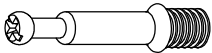
# Step 16



A x 1 PC		H x 12 PCS	
CL x 1 PC		CR x 3 PCS	

# Step 17

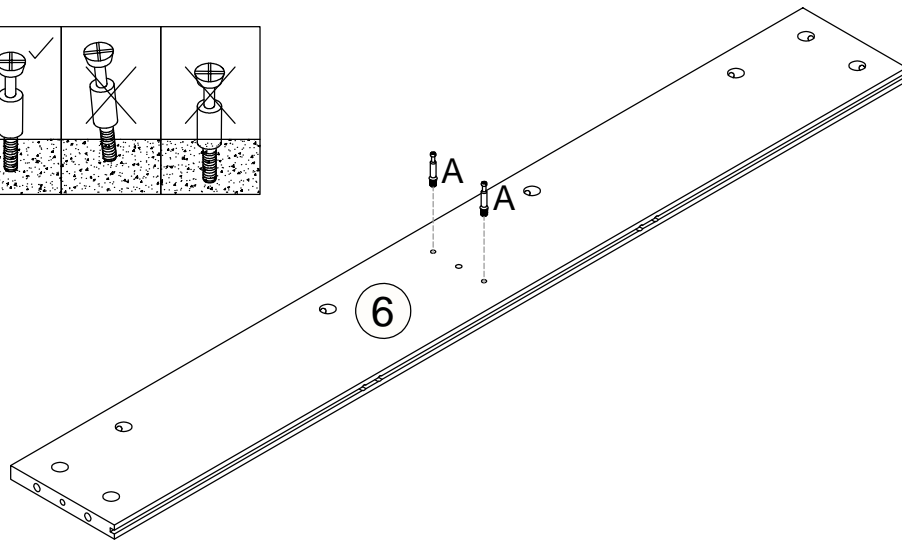
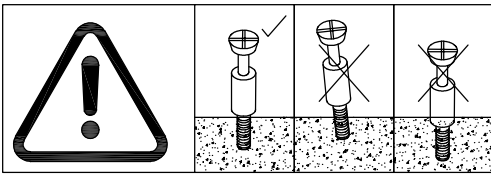

A x 2 PCS

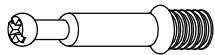

# Step 18

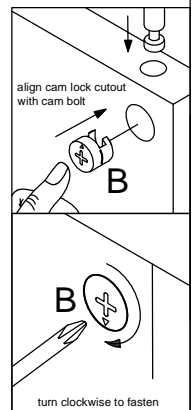
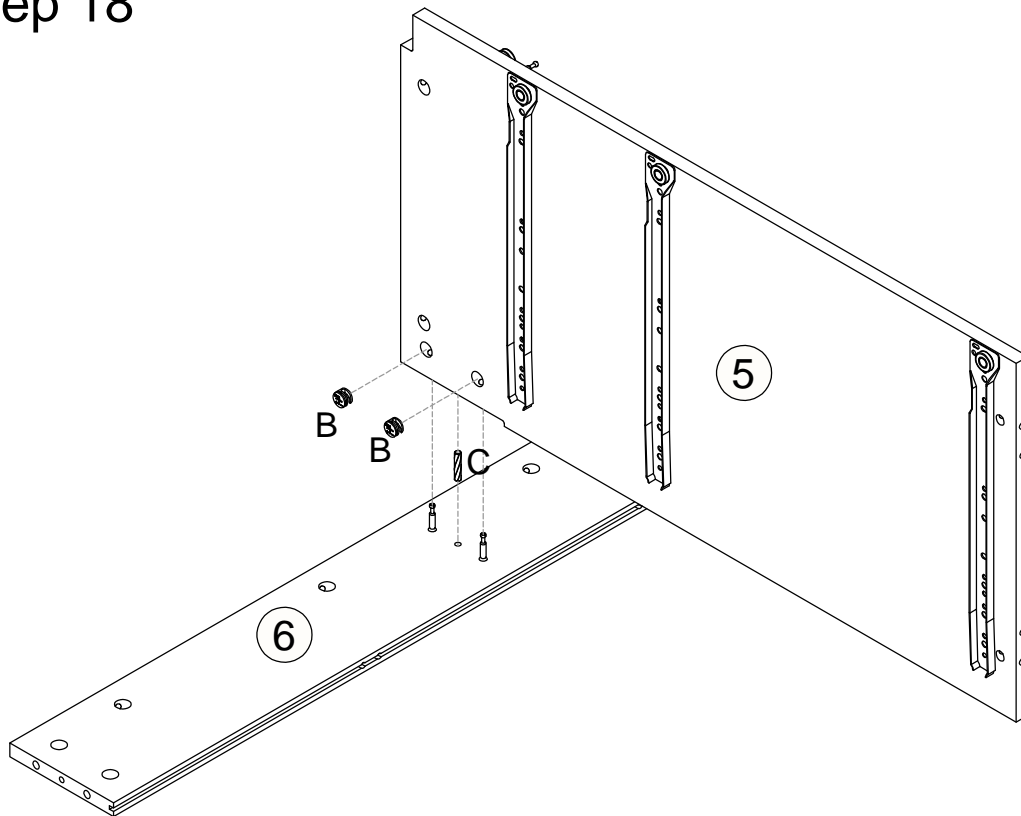

B x 2 PCS



C x 1 PC



# Step 19

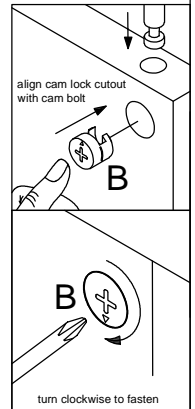
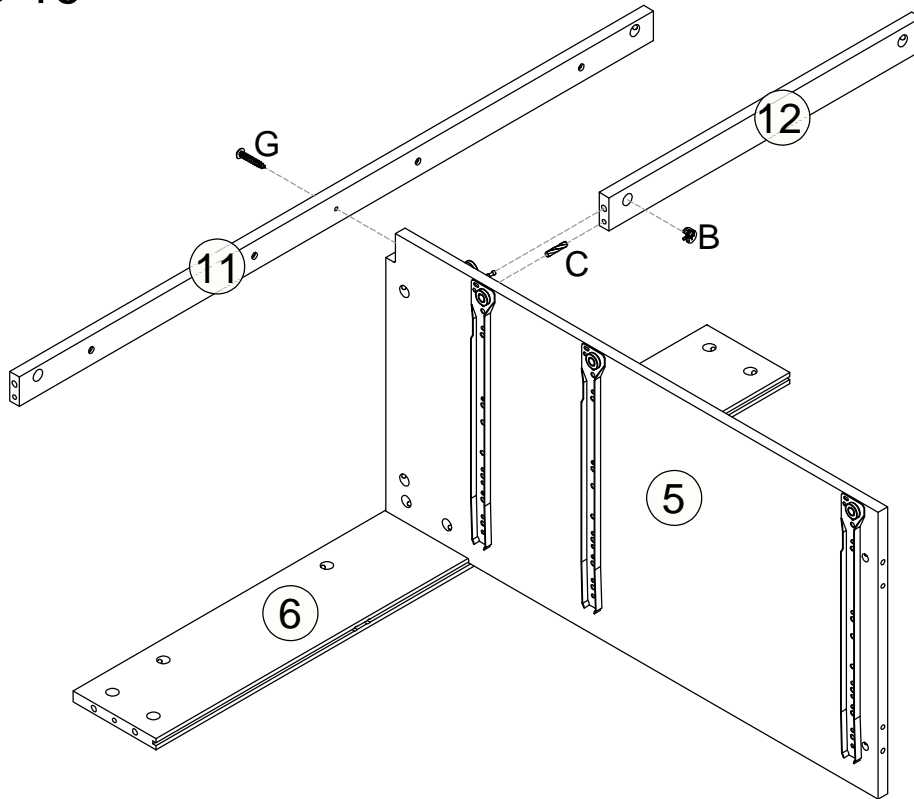

B x 1 PC



C x 1 PC



G x 1 PC



# Step 20

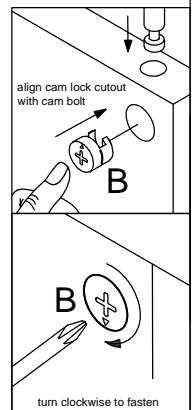
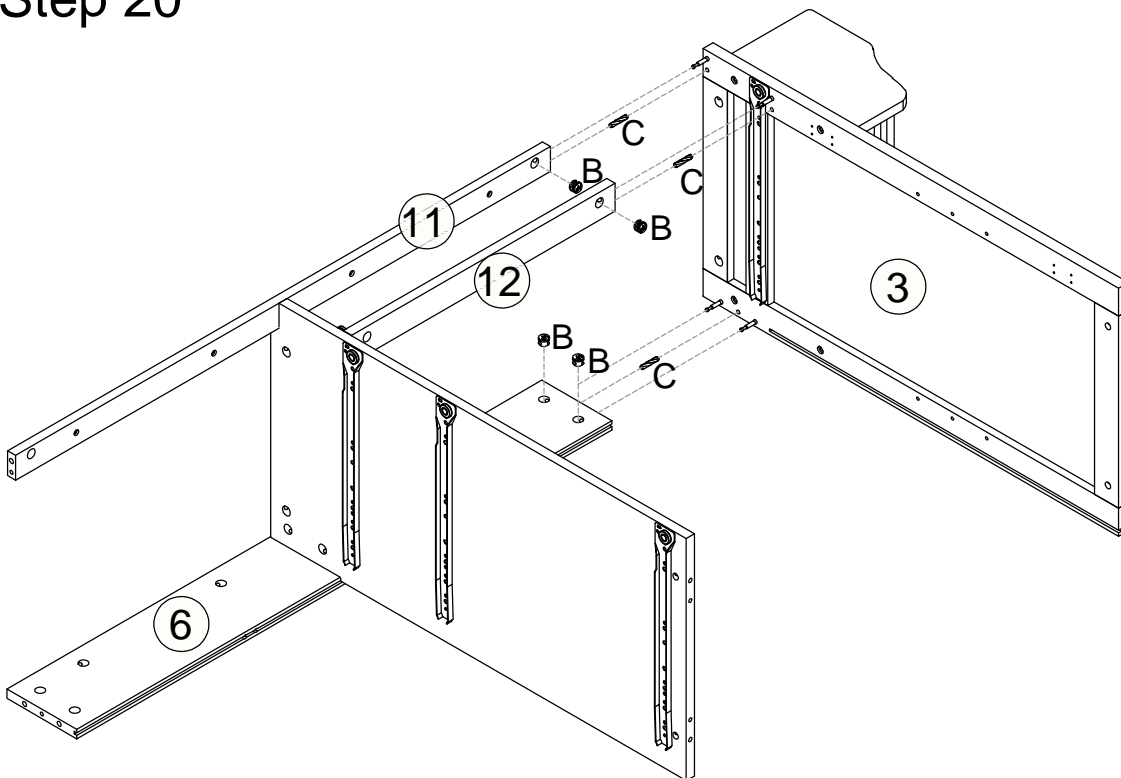

B x 4 PCS



C x 3 PCS



# Step 21

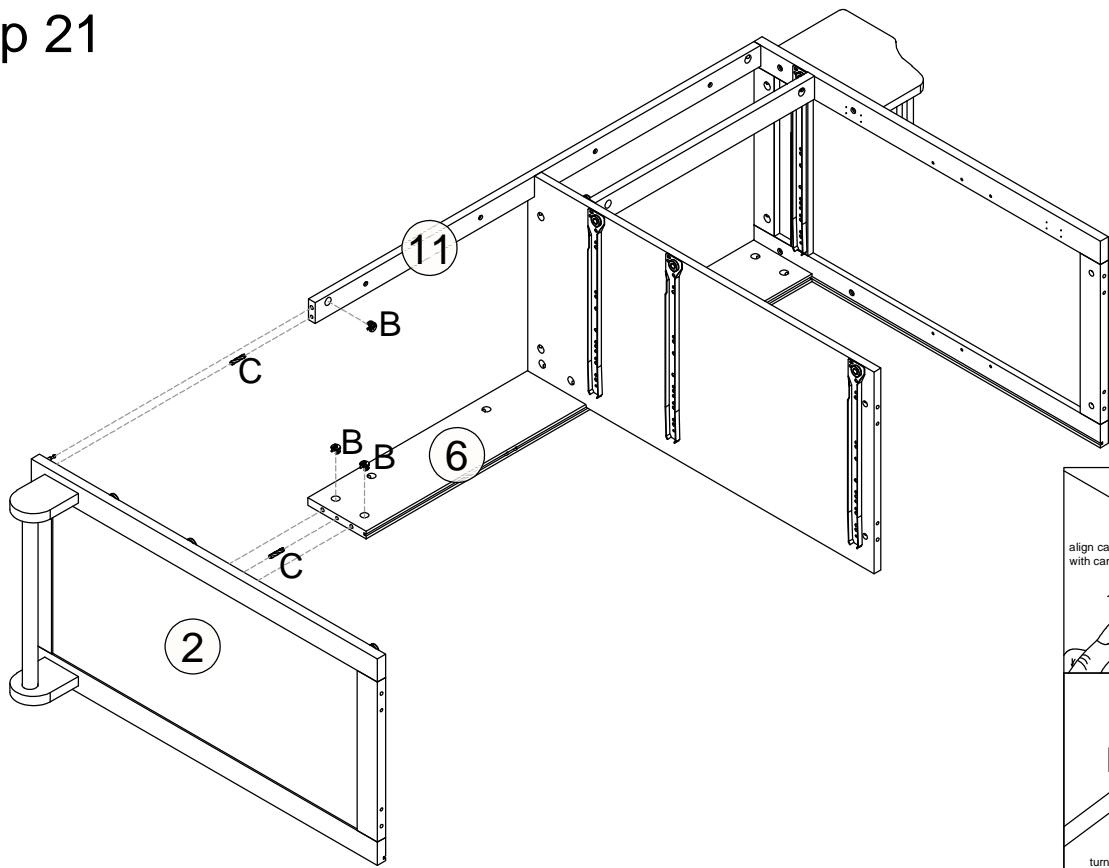

B x 3 PCS



C x 2 PCS



# Step 22

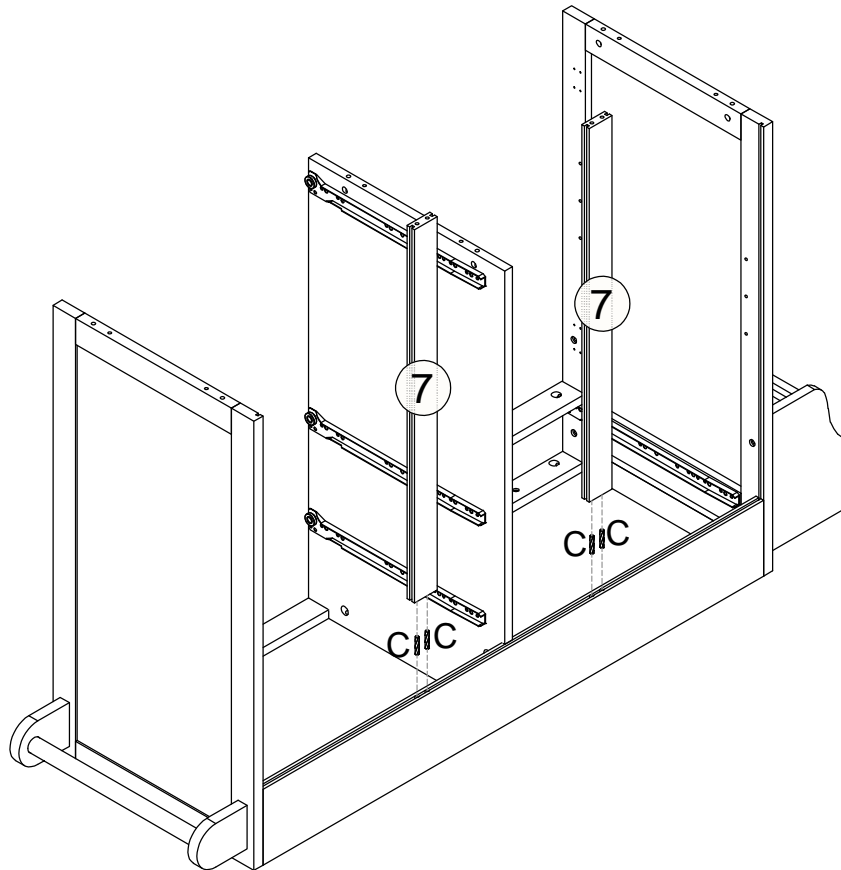

C x 4 PCS



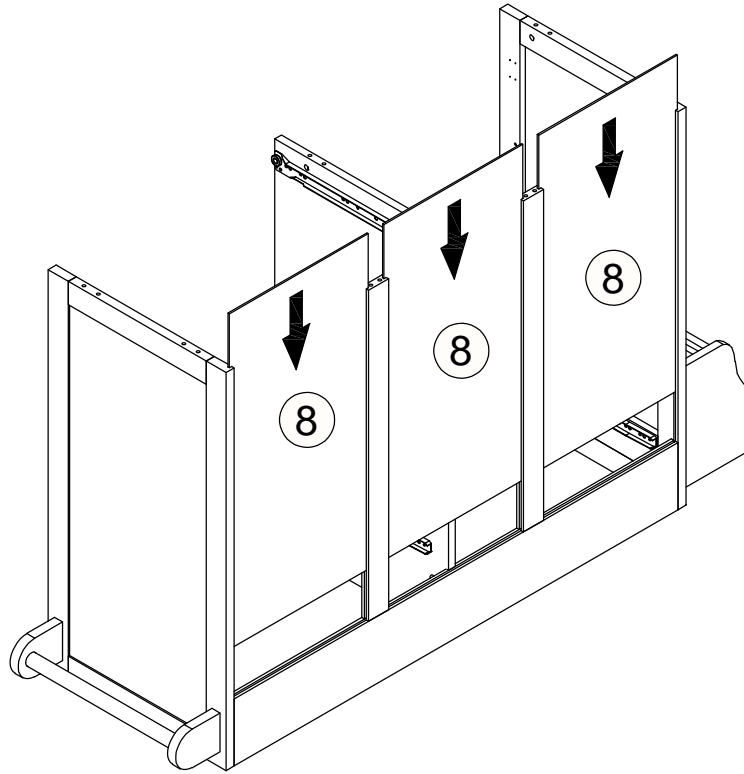

# Step 23

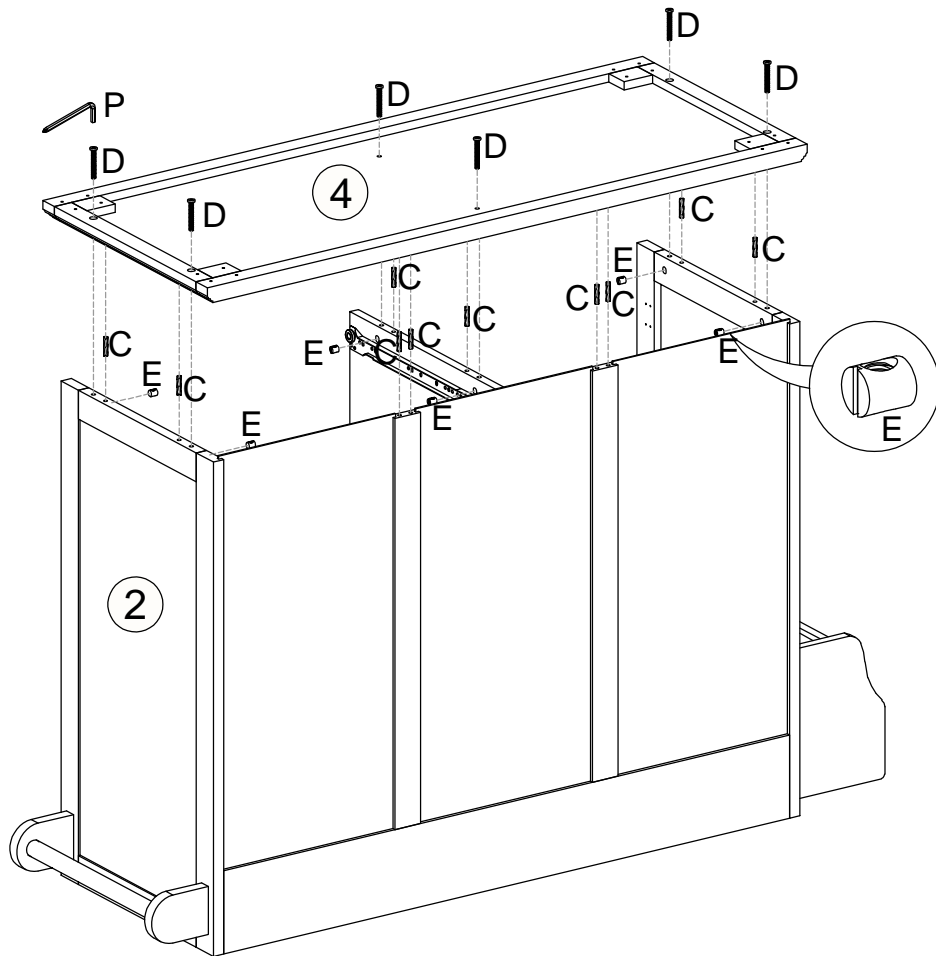

# Step 24

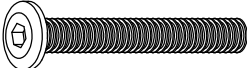

C x 10 PCS		D x 6 PCS	
E x 6 PCS		P x 1 PC	

# Step 25

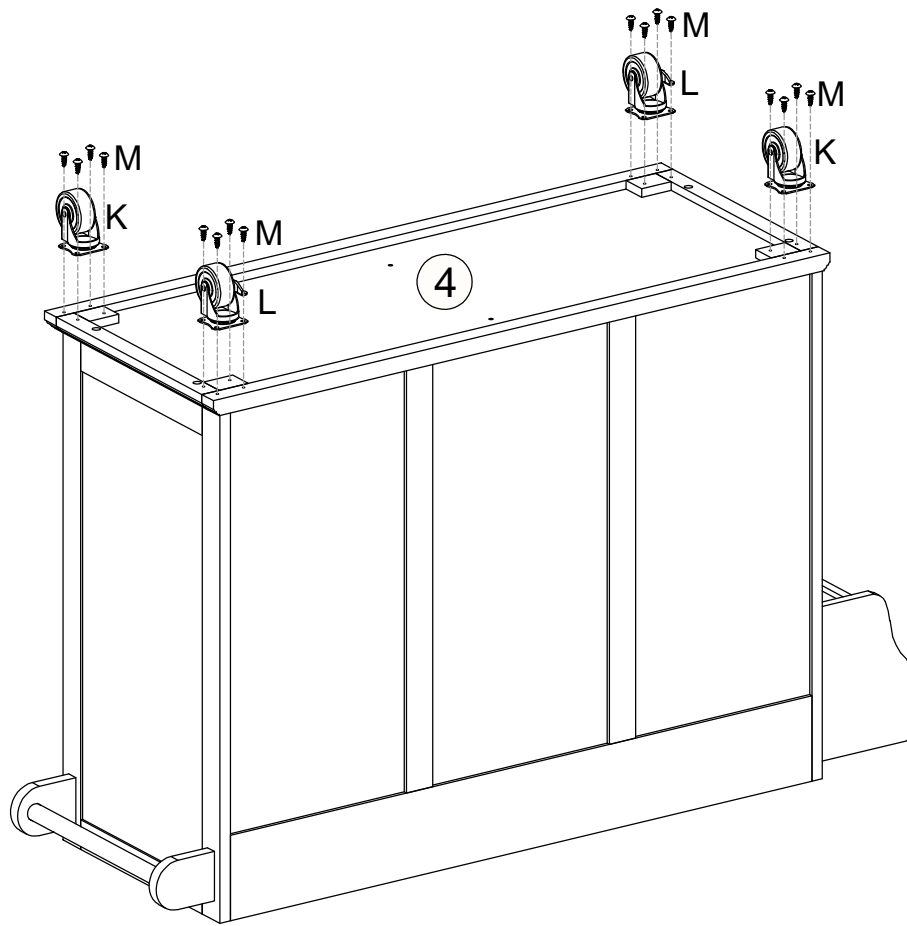

K x 2 PCS



L x 2 PCS



M x 16 PCS



# Step 26

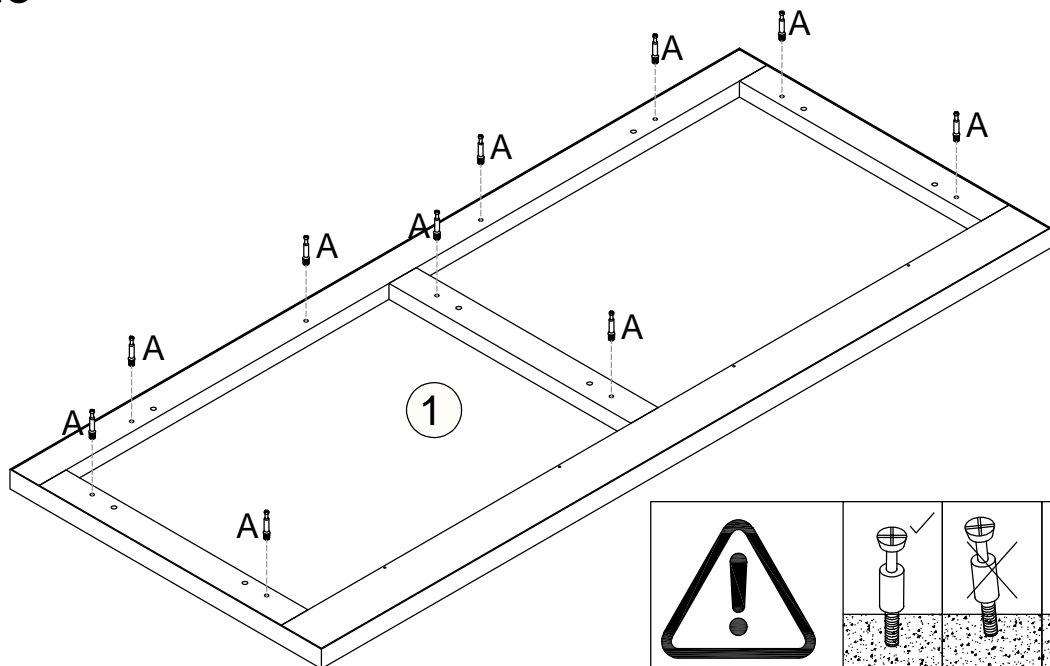

A x 10 PCS

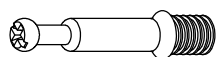

# Step 27

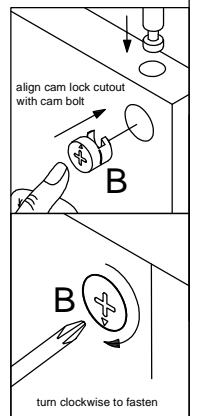
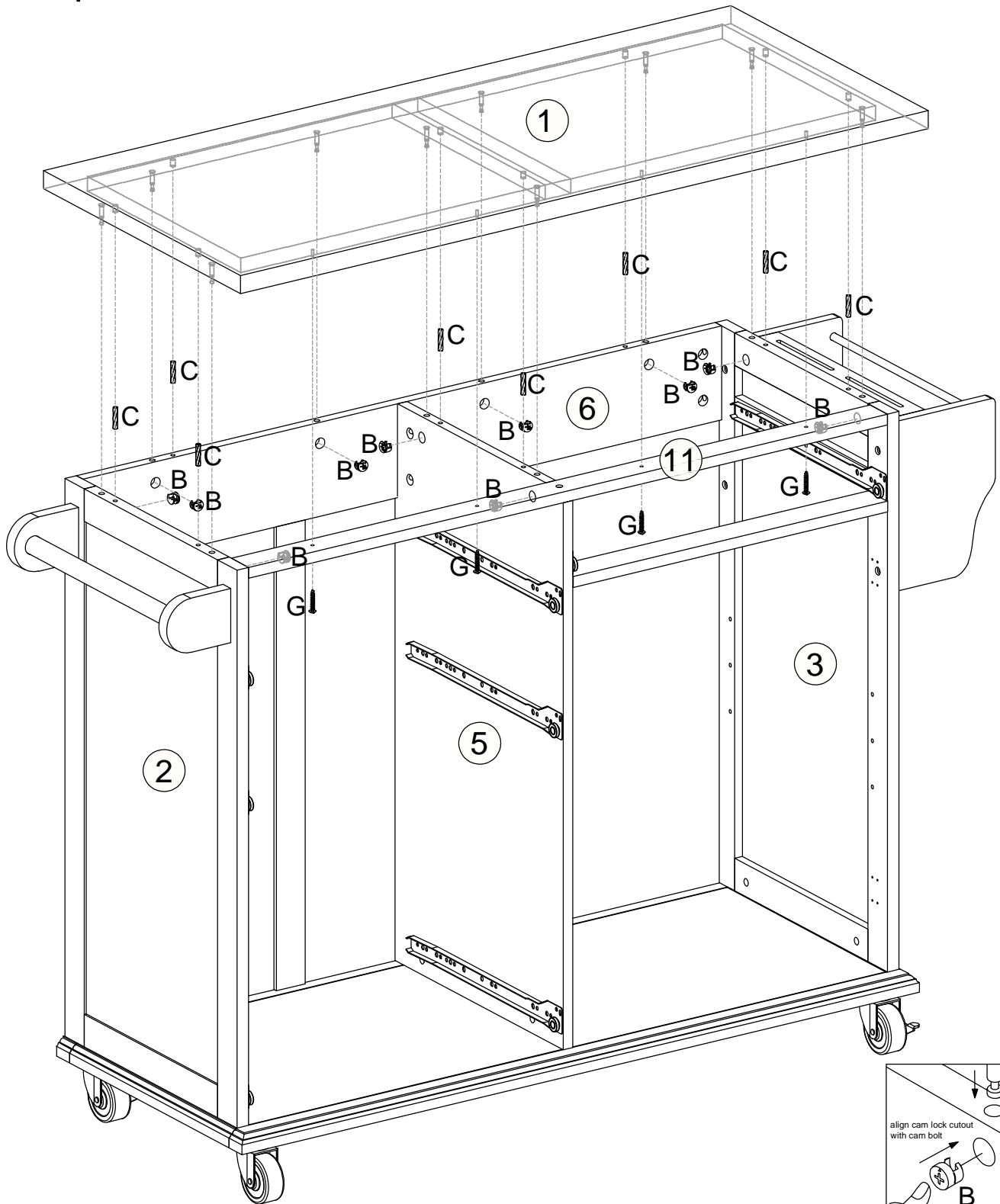

B x 10 PCS



C x 8 PCS



G x 4 PCS



# Step 28

## x2

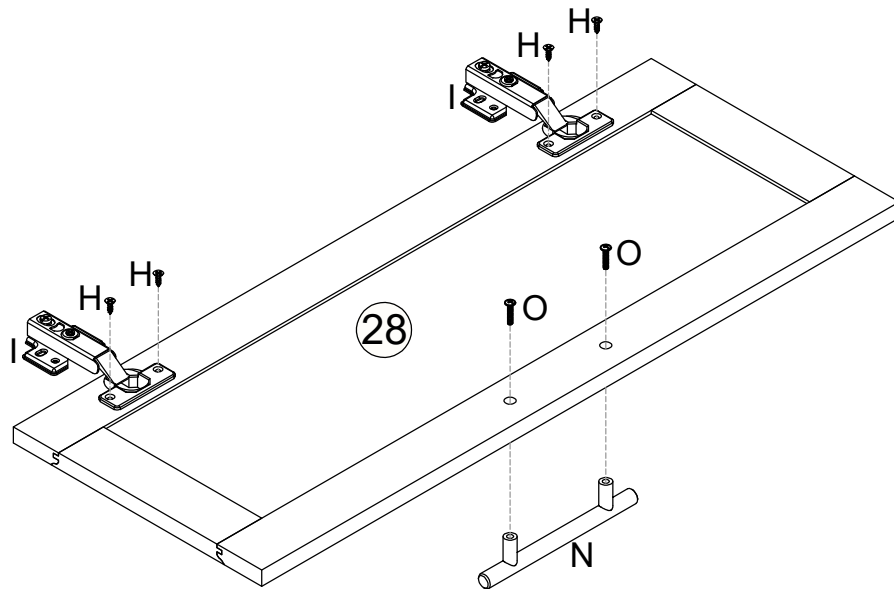

H x 8 PCS		I x 4 PCS	
N x 2 PCS		O x 4 PCS	

# Step 29

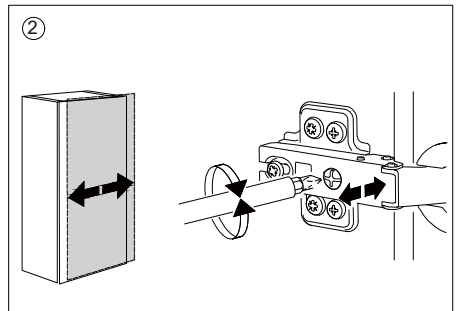
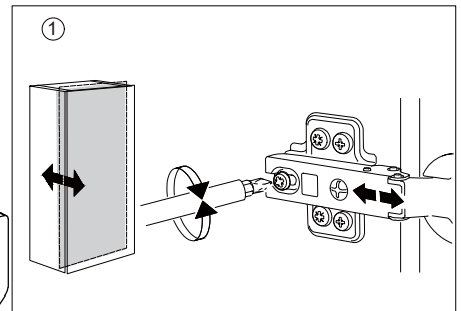
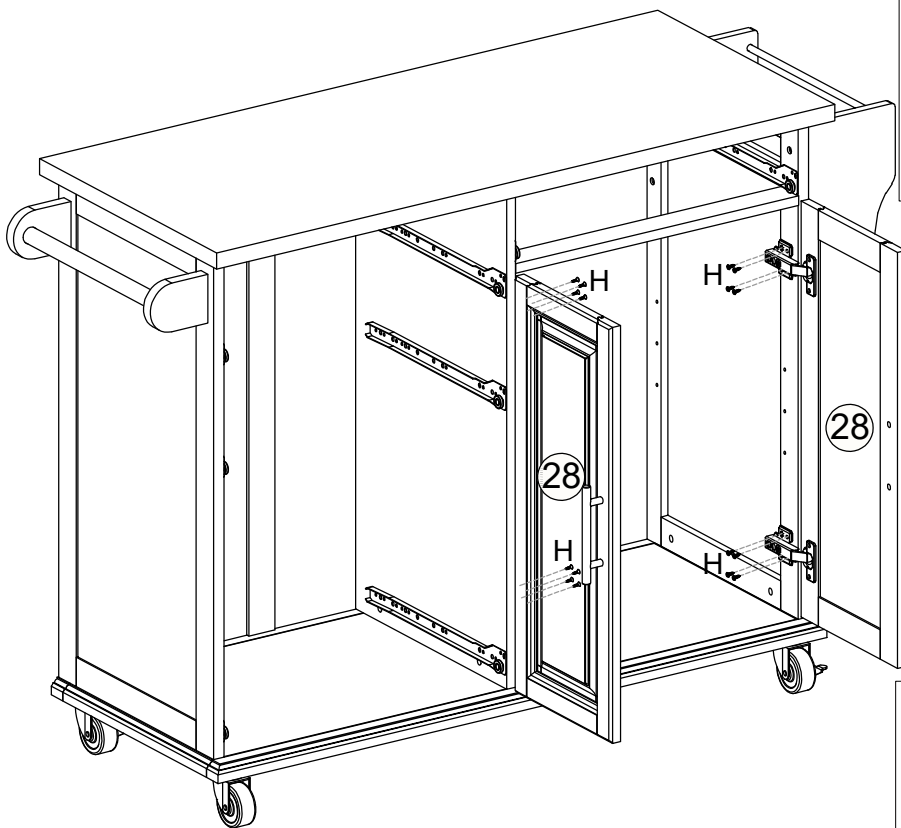

H x 16 PCS	
------------	--

# Step 30

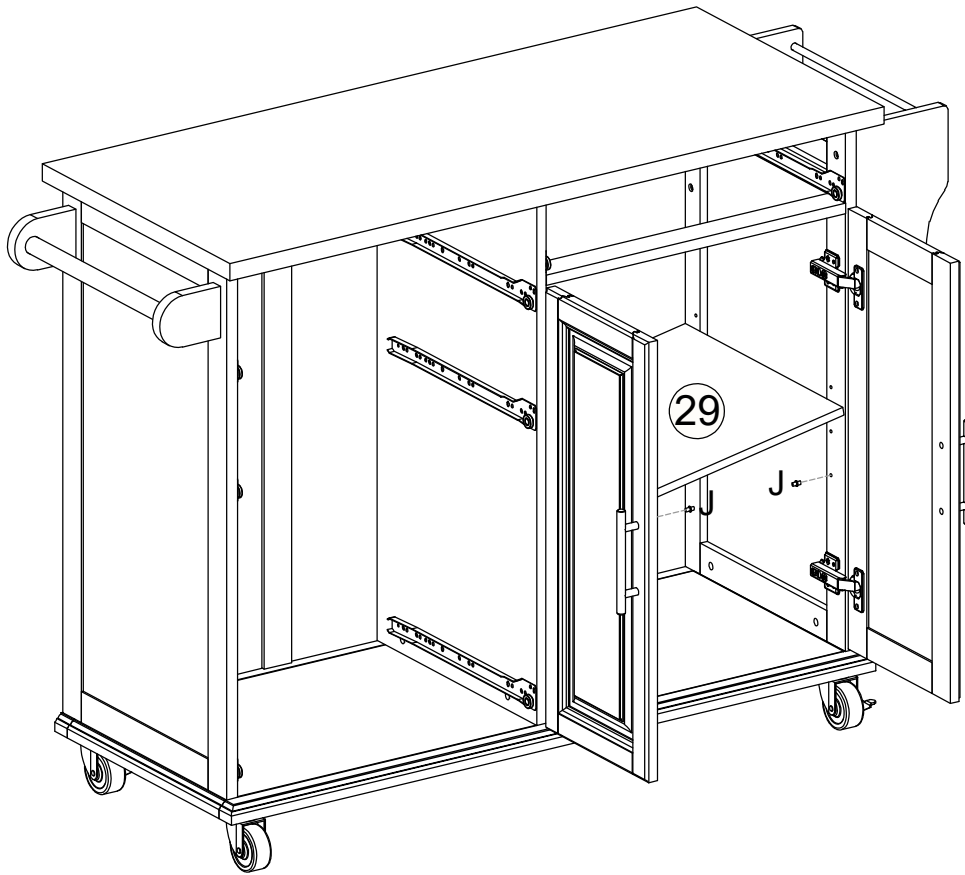

J x 4 PCS

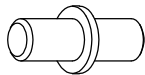

# Step 31

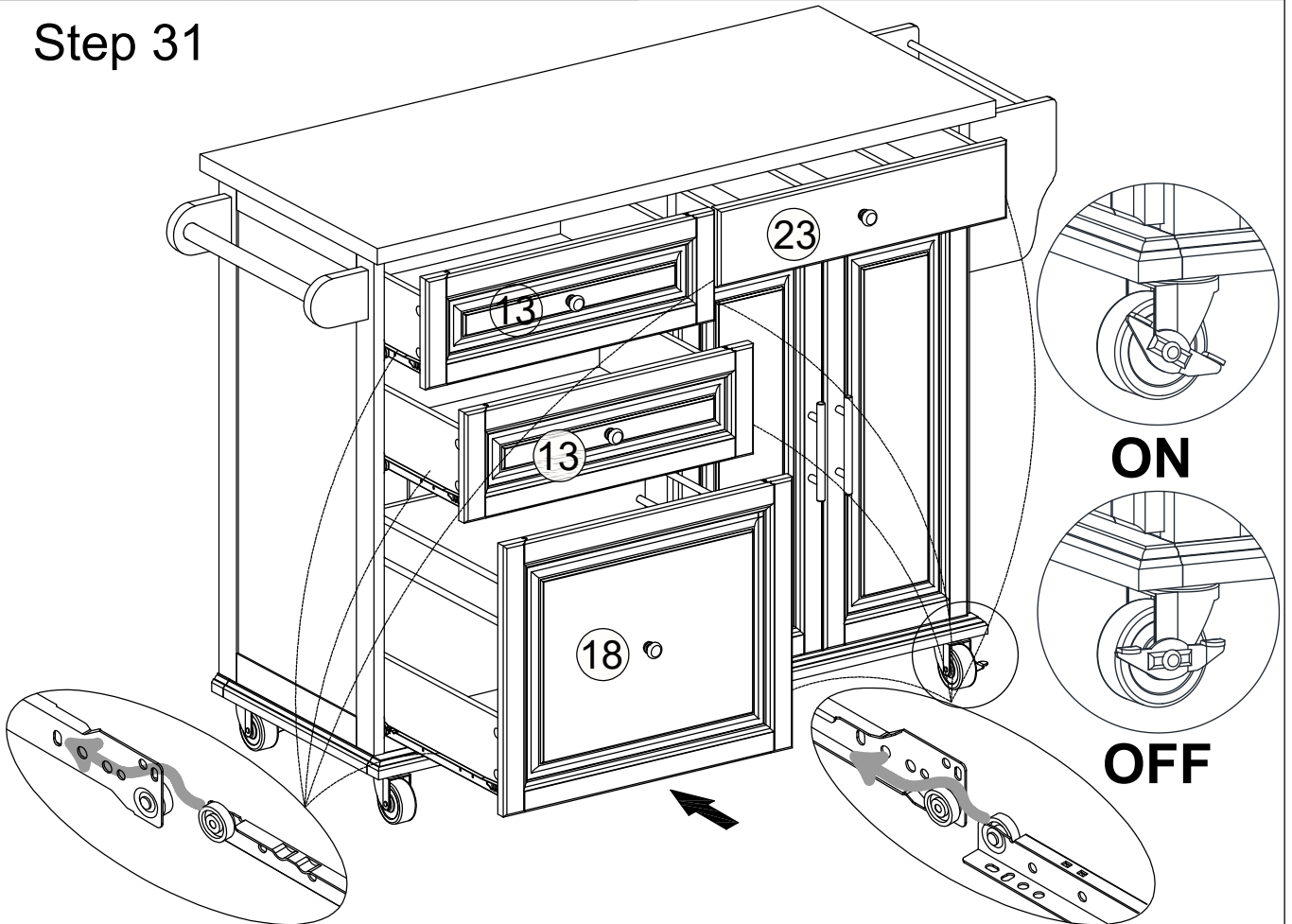

**ON**

**OFF**

## Questions & Answers about Proposition 65

### \* What is Proposition 65?

Proposition 65 requires businesses to provide warnings to Californians about significant exposures to chemicals that cause cancer, birth defects or other reproductive harm. These chemicals can be in the products that Californians purchase, in their homes or workplaces, or that are released into the environment. By requiring that this information be provided, Proposition 65 enables Californians to make informed decisions about their exposures to these chemicals.

Proposition 65 also prohibits California businesses from knowingly discharging significant amounts of listed chemicals into sources of drinking water.

Proposition 65 requires California to publish a list of chemicals known to cause cancer, birth defects or other reproductive harm. This list, which must be updated at least once a year, has grown to include approximately 900 chemicals since it was first published in 1987.

### \* What types of chemicals are on the Proposition 65 list?

The list contains a wide range of naturally occurring and synthetic chemicals that include additives or ingredients in pesticides, common household products, food, drugs, dyes, or solvents. Listed chemicals may also be used in manufacturing and construction, or they may be byproducts of chemical processes, such as motor vehicle exhaust.

### \* What does a warning mean?

If a warning is placed on a product label or posted or distributed at a workplace, a business, or in rental housing, the business issuing the warning is aware or believes that it is exposing individuals to one or more listed chemicals.

By law, a warning must be given for listed chemicals unless the exposure is low enough to pose no significant risk of cancer or is significantly below levels observed to cause birth defects or other reproductive harm.

### \* Where can I get more information on Proposition 65?

If you have specific questions on the administration or implementation of Proposition 65, you can contact OEHHA's Proposition 65 program at [P65.Questions@oehha.ca.gov](mailto:P65.Questions@oehha.ca.gov), or by phone at (916) 445-6900.