

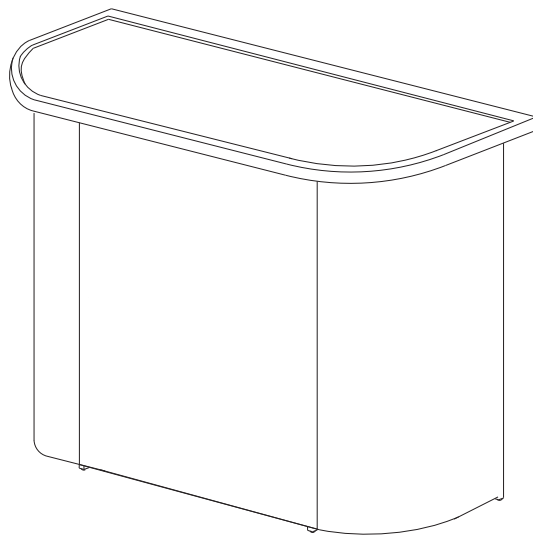











Outdoor Wicker Bar



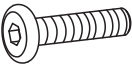
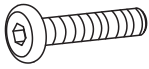



PART LIST

				
<p>Wicker Top 1 PC</p>	<p>Center Panel 1 PC</p>	<p>Left Side Panel 1 PC</p>	<p>Right Side Panel 1 PC</p>	<p>Wicker Shelf 2 PCS</p>
				
<p>Glass Top 1 PC</p>				

HARDWARE LIST

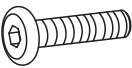
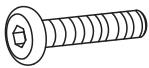
 <p>M6*40mm</p>	 <p>M6*65mm</p>	 <p>M6mm</p>	 <p>M6mm</p>	 <p>M6mm</p>
<p>Short Bolt 12 PCS</p>	<p>Long Bolt 6 PCS</p>	<p>Washer 24 PCS</p>	<p>Nut 6 PCS</p>	<p>Allen Key 1 PC</p>
 <p>M6mm</p>	 <p>M6mm</p>			
<p>Wrench 1 PC</p>	<p>Adjustable Leveler 4 PCS</p>			

EXTRA HARDWARE LIST

 <p>M6*40mm</p>	 <p>M6*65mm</p>	 <p>M6mm</p>	 <p>M6mm</p>	 <p>M6mm</p>
<p>Short Bolt 3 PCS</p>	<p>Long Bolt 1 PC</p>	<p>Washer 3 PCS</p>	<p>Nut 2 PCS</p>	<p>Adjustable Leveler 1 PC</p>

Step 1. Lay wicker top (part #A) on a flat surface with underside facing up. Attach center panel (part #B) to wicker top (part #A) using short bolts (part #1), washers (part #3) and allen key (part #5).

NOTE: Please do not fully tighten bolts until unit is fully assembled.

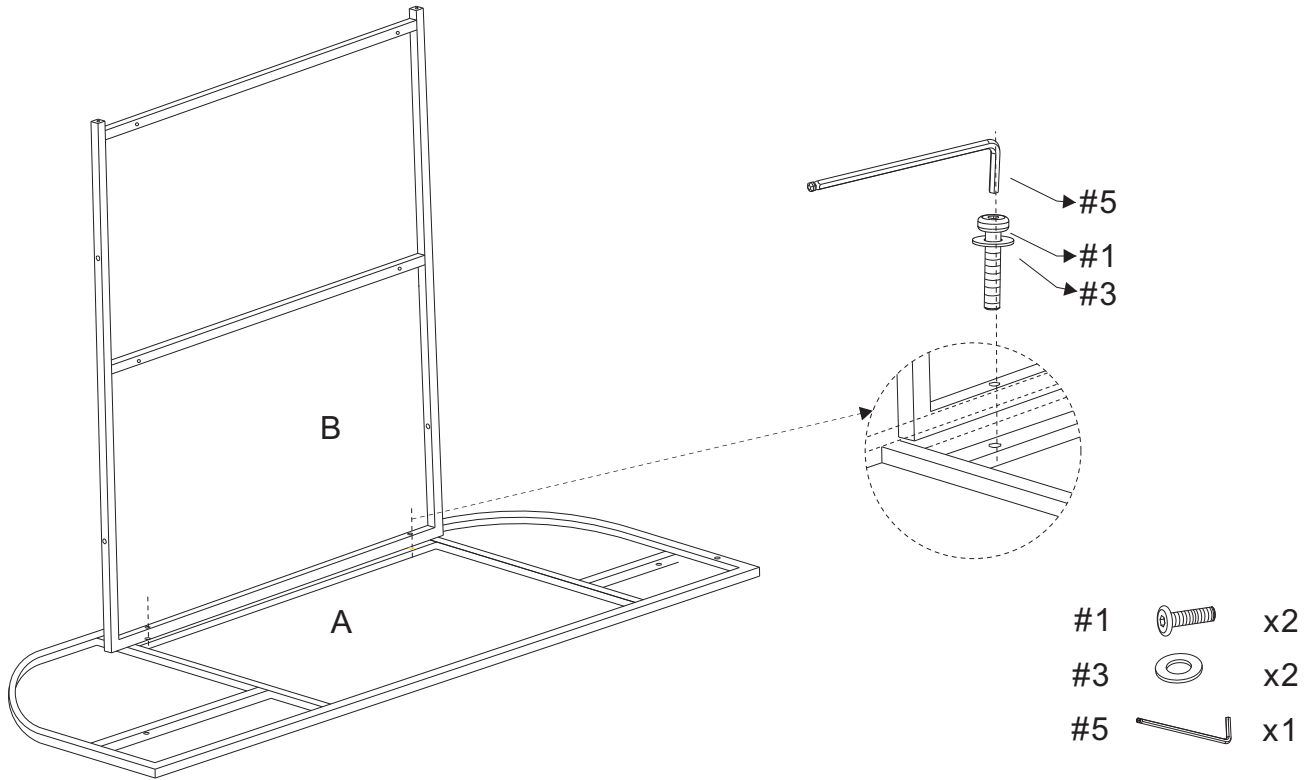

Step 2. Attach left side panel (part #C) and right side panel (part #D) to assembled parts (part #A&B) using short bolts (part #1), long bolts (part #2), washers (part #3), nut (part #4) and allen key (part #5).

NOTE: Please do not fully tighten bolts until unit is fully assembled.

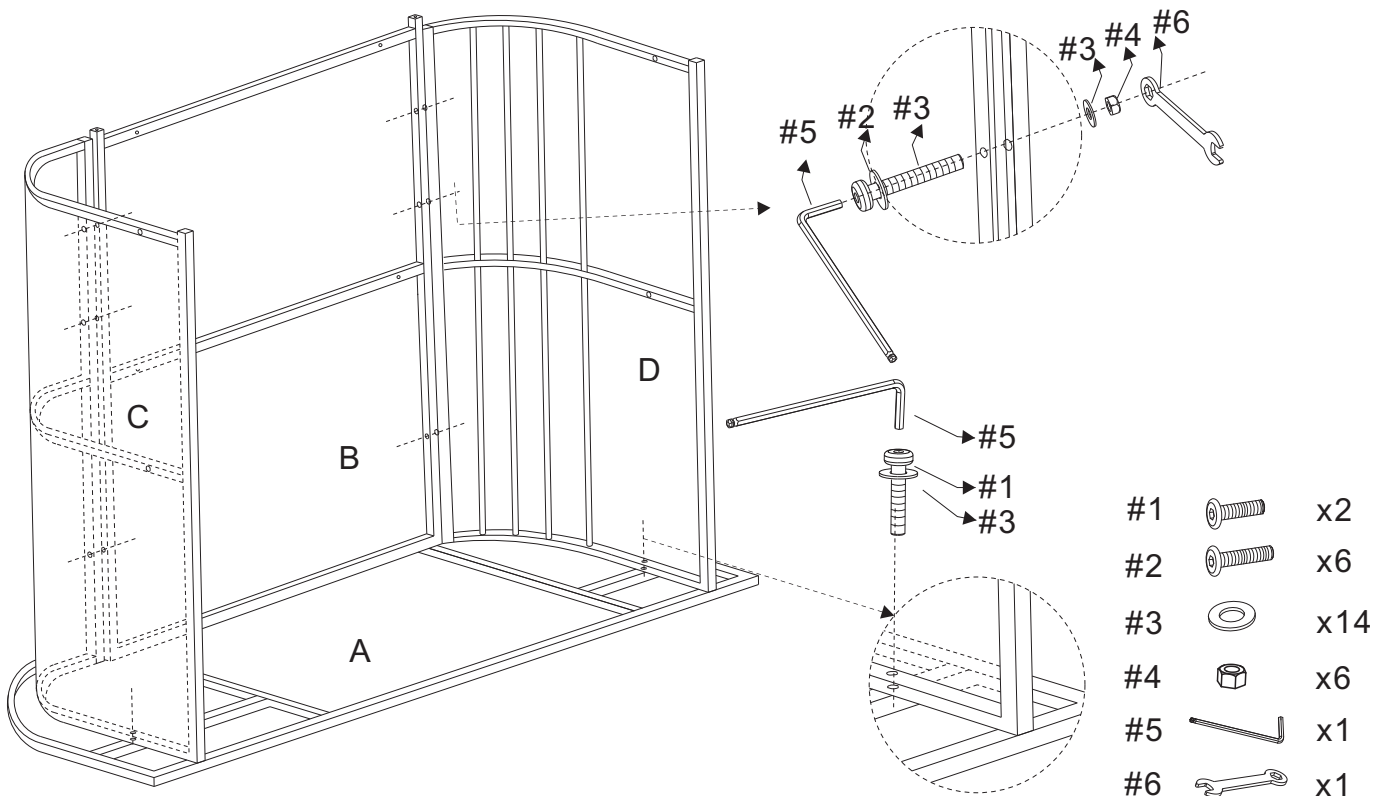

Step 3. Attach one shelf (part #E) to assembled parts (part #B,C&D) using short bolts (part #1), washers (part #3) and allen key (part #5).

NOTE: Please do not fully tighten bolts until unit is fully assembled.

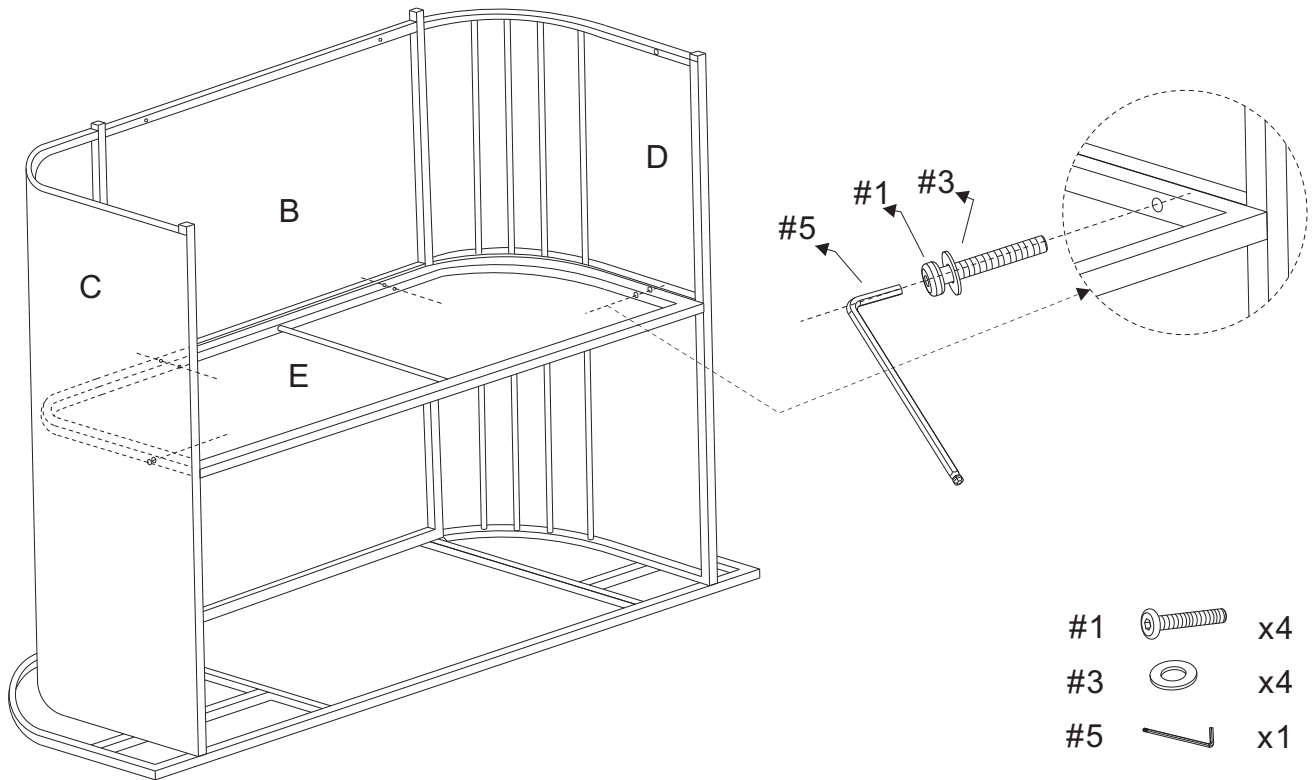

Step 4. Attach another shelf (part #E) to assembled parts (part #B,C&D) using short bolts (part #1), washers (part #3) and allen key (part #5).

NOTE: Please fully tighten all bolts at this time.

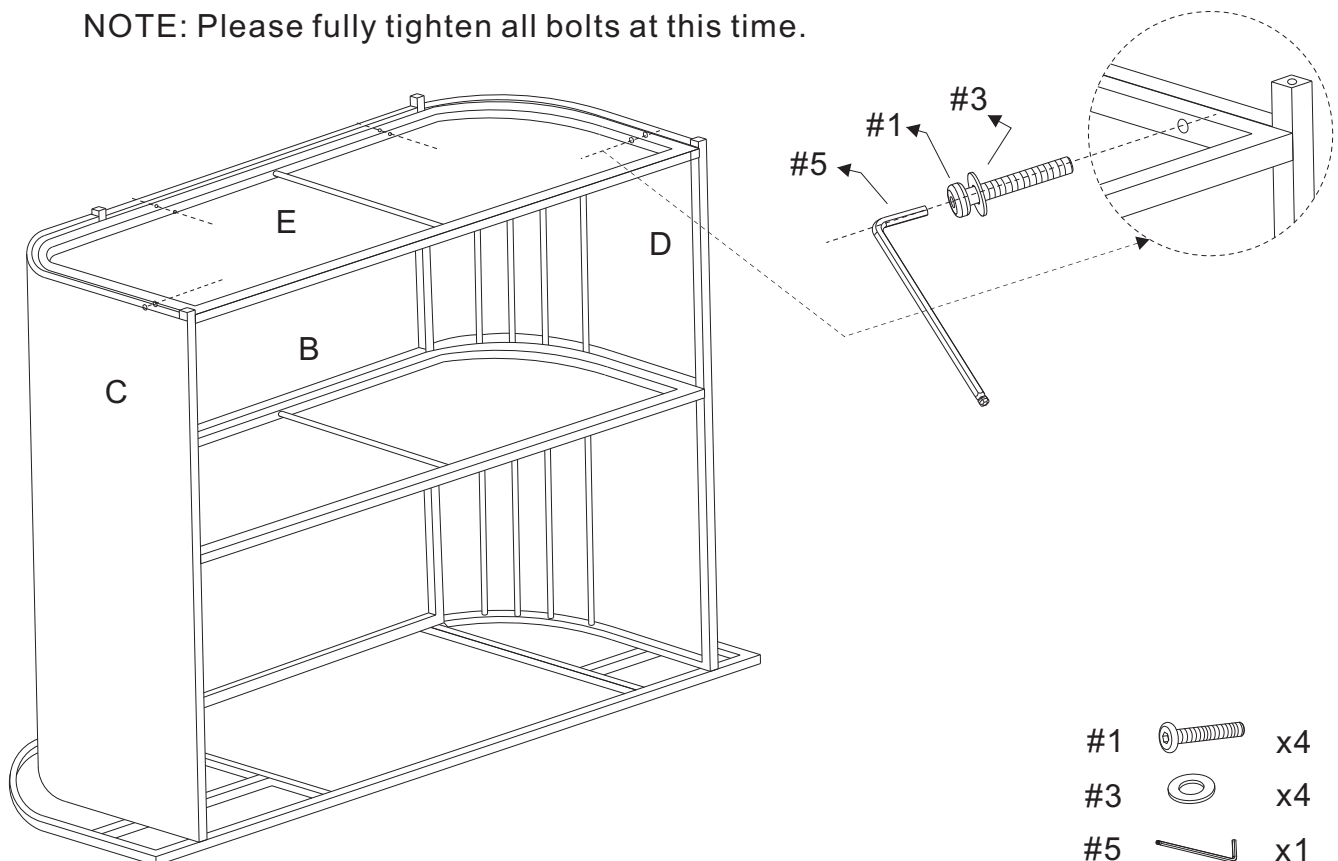

Step 5. Screw the adjustable levelers (part #7) into the pre-drilled holes to the desired position on the bottom of the bar.

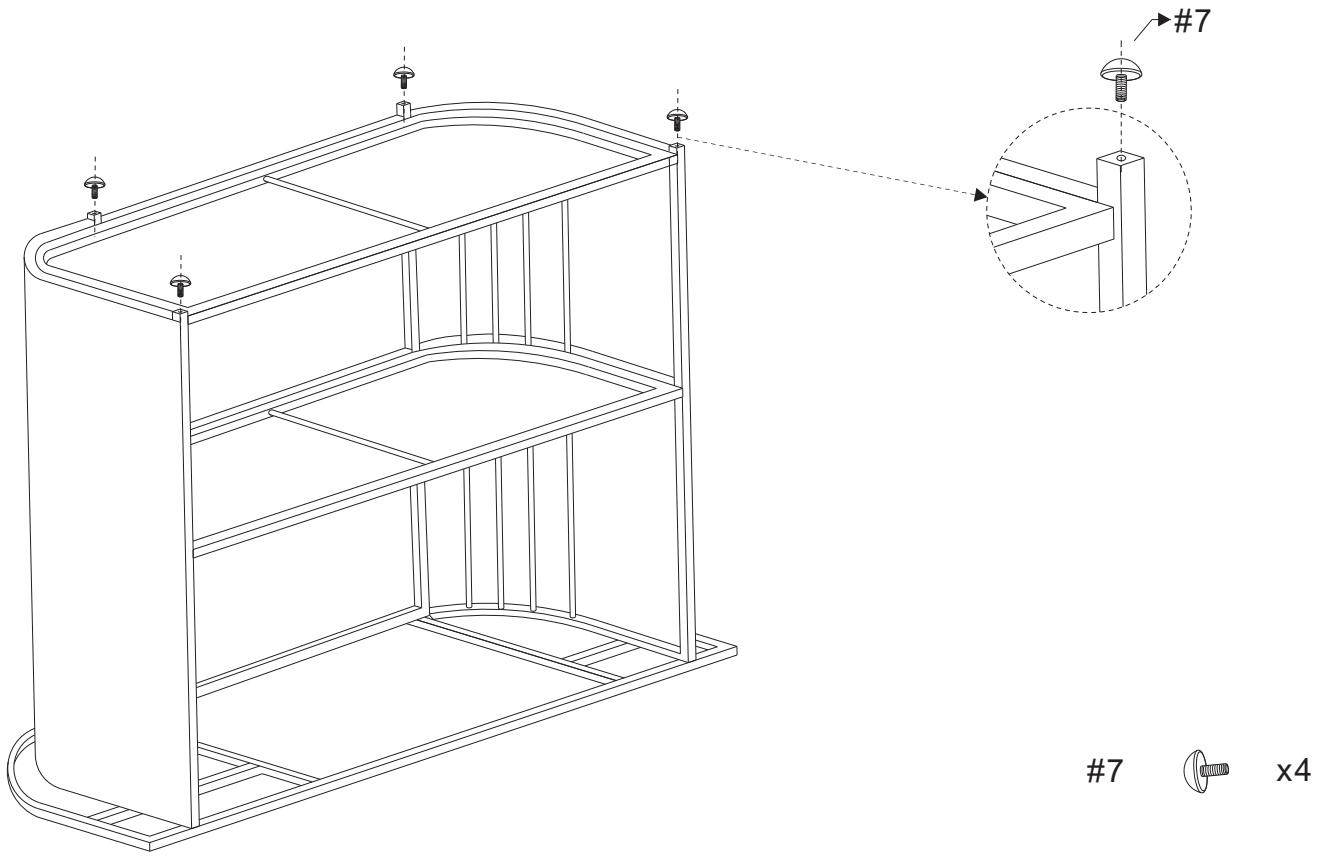

Step 6. Carefully turn the bar upright and place the glass (part #F) on the bar top.

