

Assembly Manual

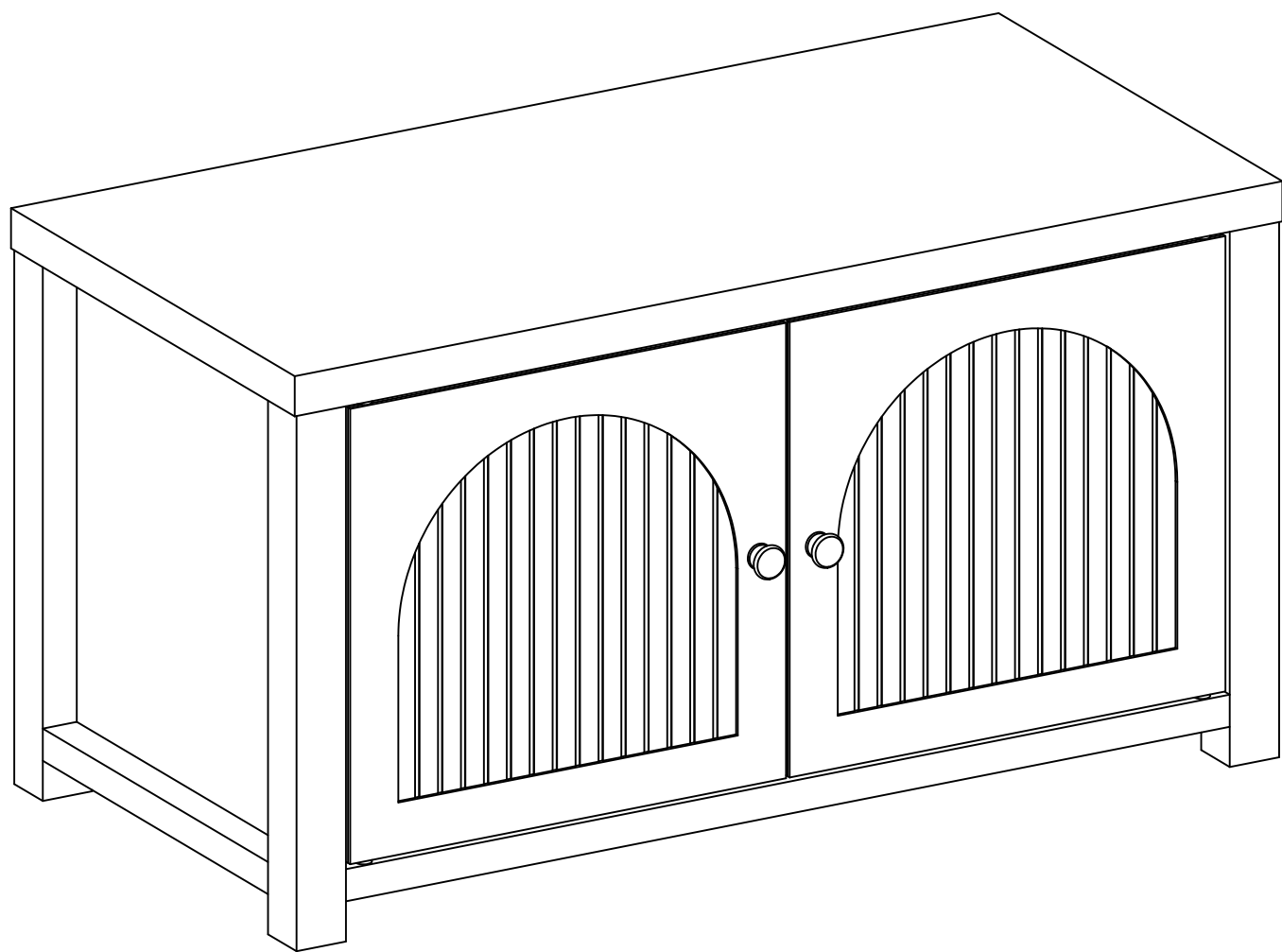

ASSEMBLY INSTRUCTION

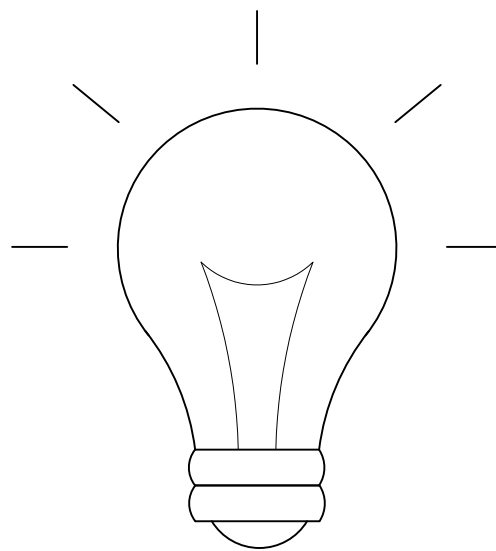

friendly reminder

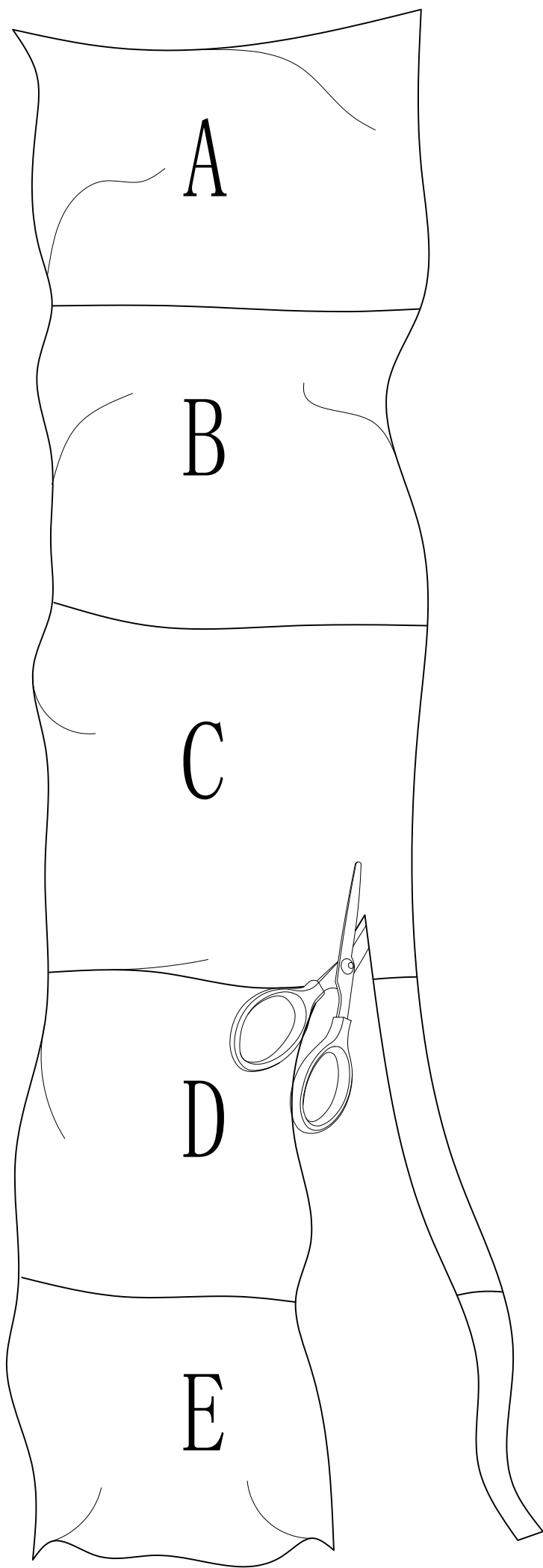

To avoid errors and confusion during the installation of accessories, use the type and quantity of hardware accessories according to the installation procedure described in the instructions. First, unroll the accessories bag and lay out the hardware accessories, cut holes in the side, and take out the hardware accessories

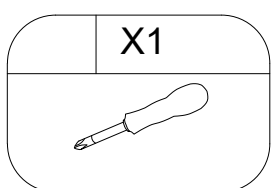
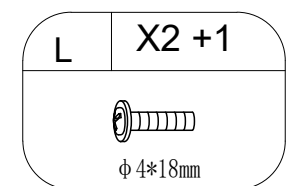
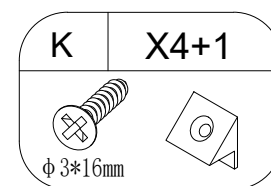
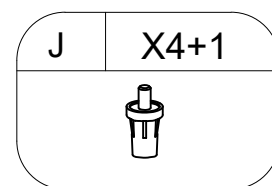
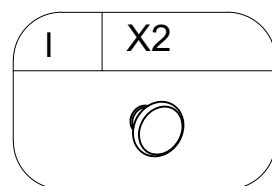
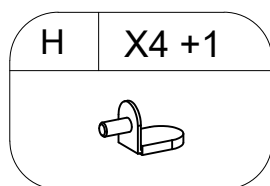
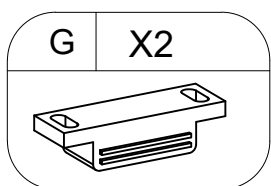
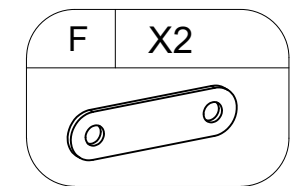
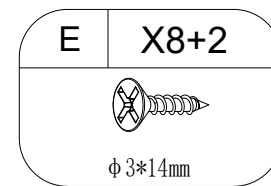
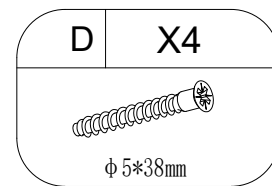
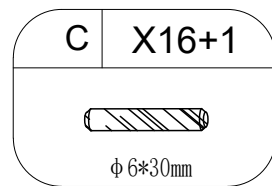
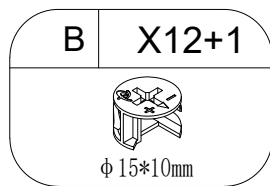
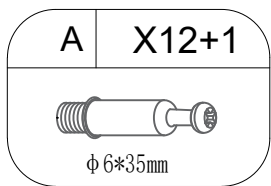
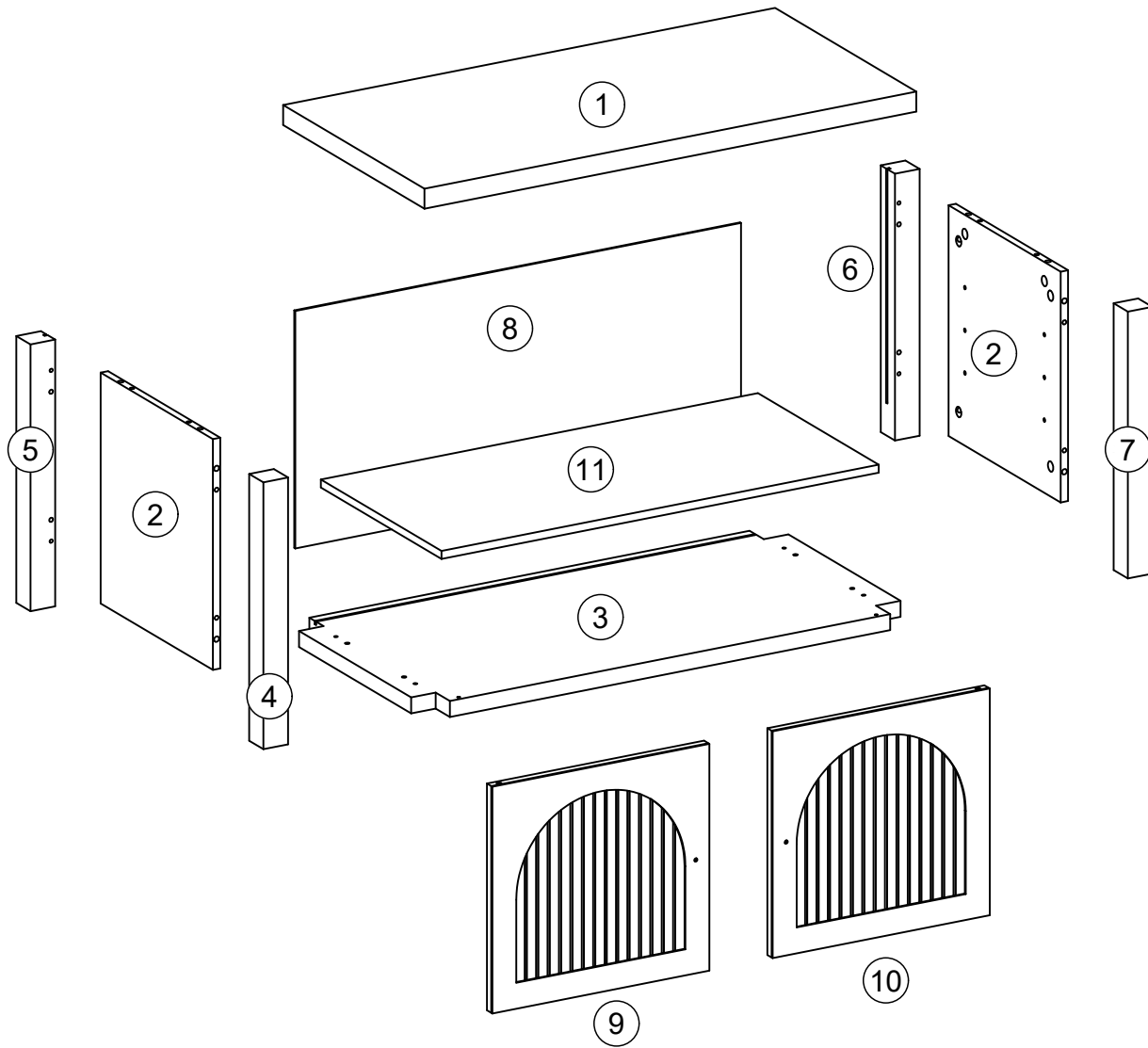

Packaging Details

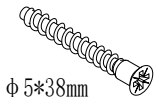

Step 1

D	X4
 φ 5*38mm	
C	X4
 φ 6*30mm	

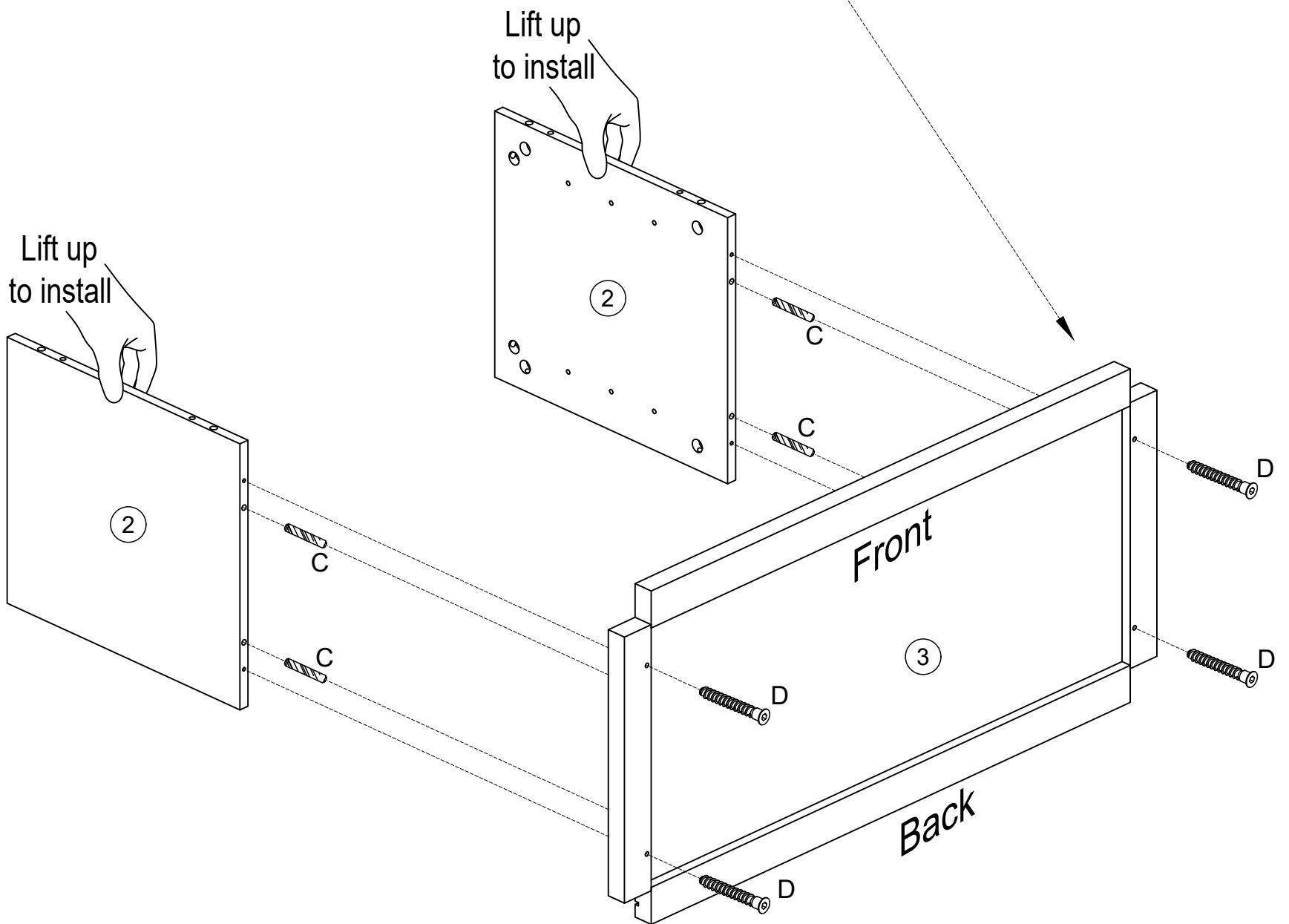
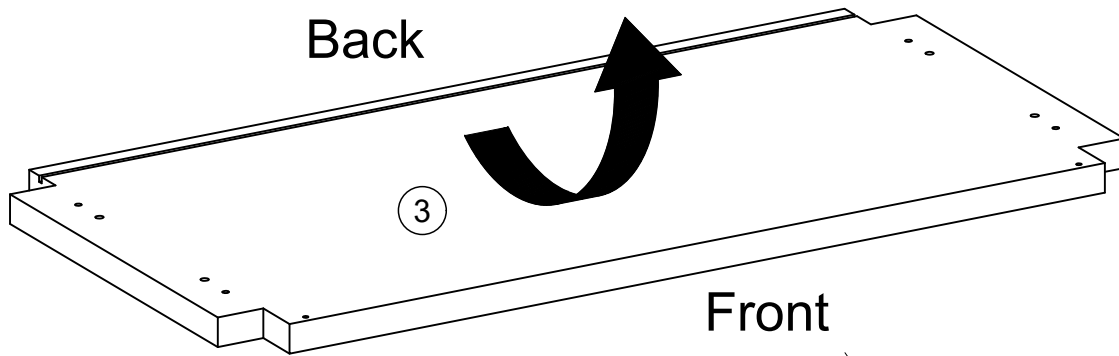

Step 2

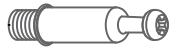
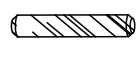
A	X8
 φ 6*35mm	
C	X8
 φ 6*30mm	

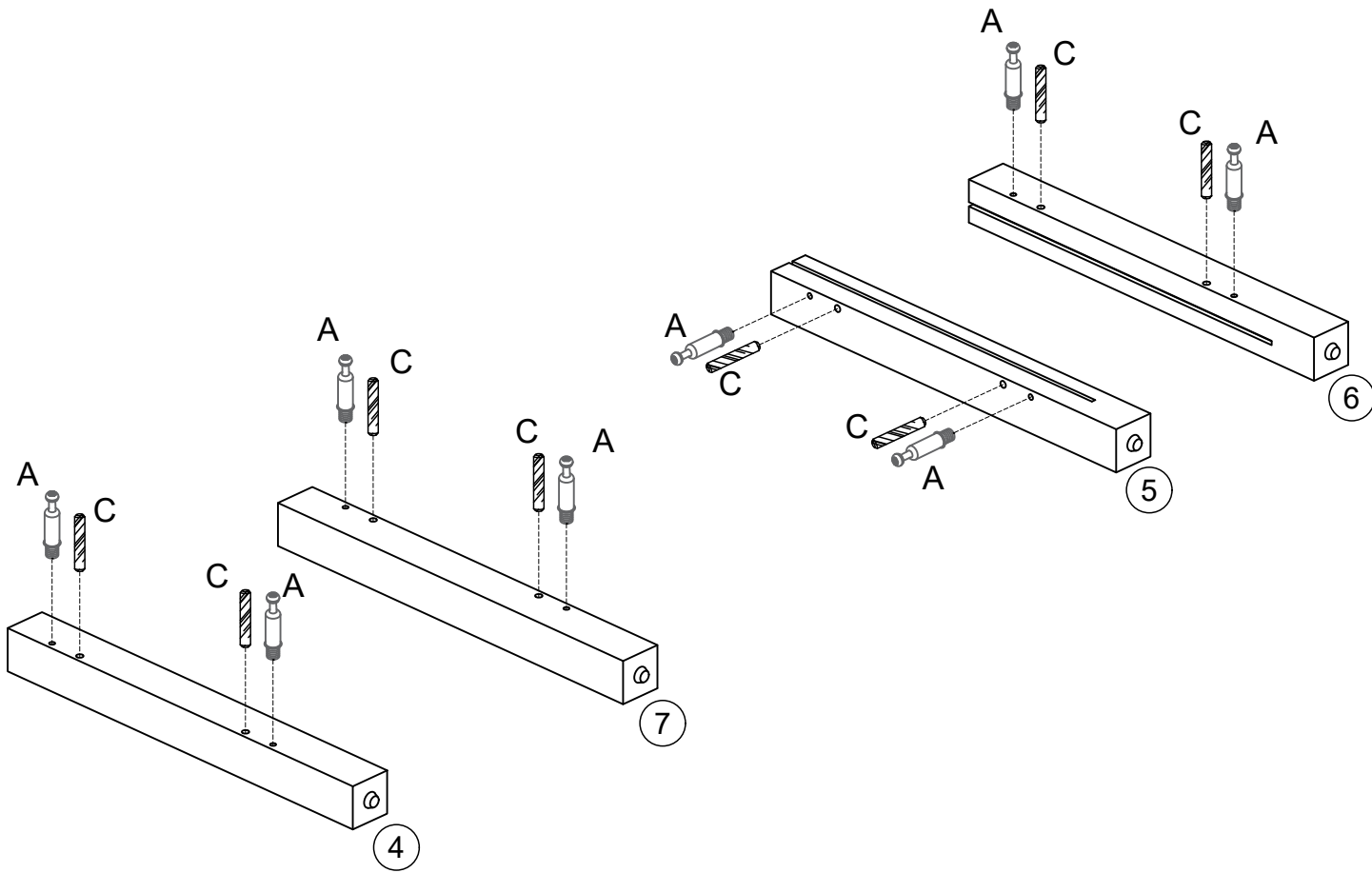

Step 3

Pay attention to the positions of ⑤ and ④ as shown in the diagram

B	X4
 φ 15*10mm	

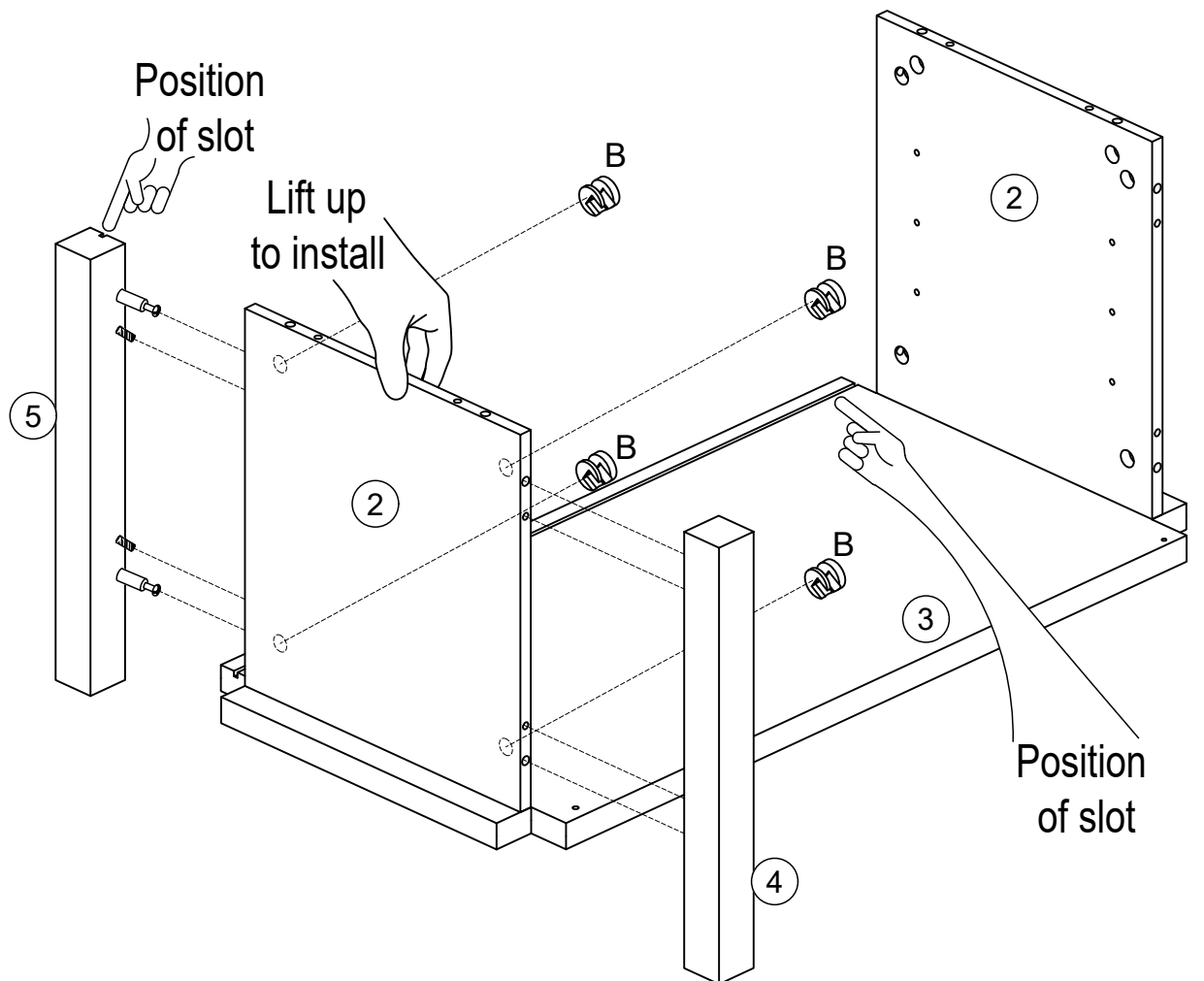
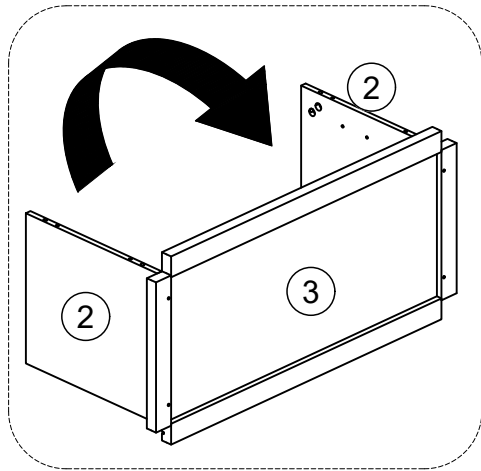

Step 4

Pay attention to the positions of ⑥ and ⑦ as shown in the diagram

B	X4
 φ 15*10mm	

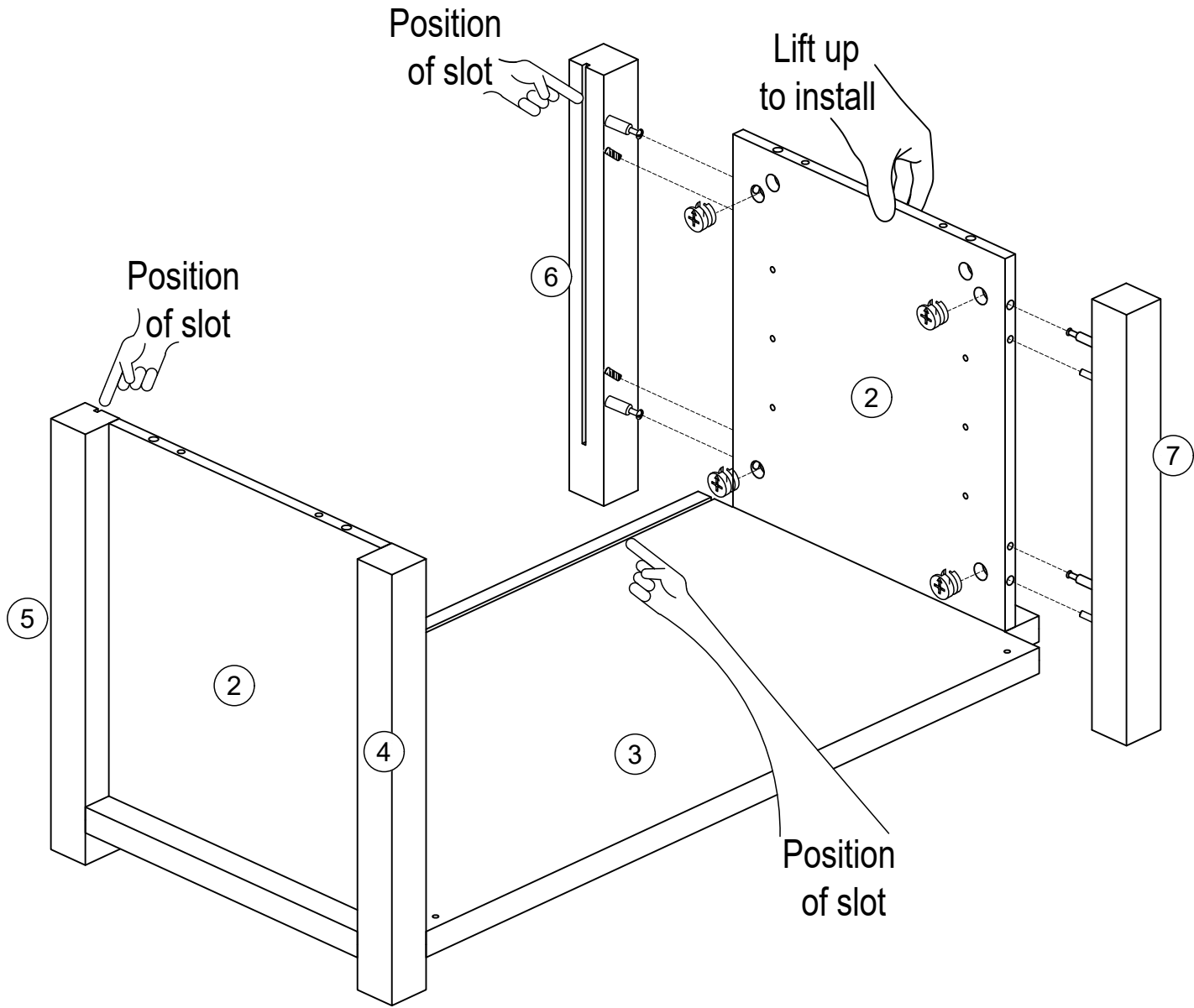

Step 5

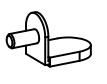
H	X4
	

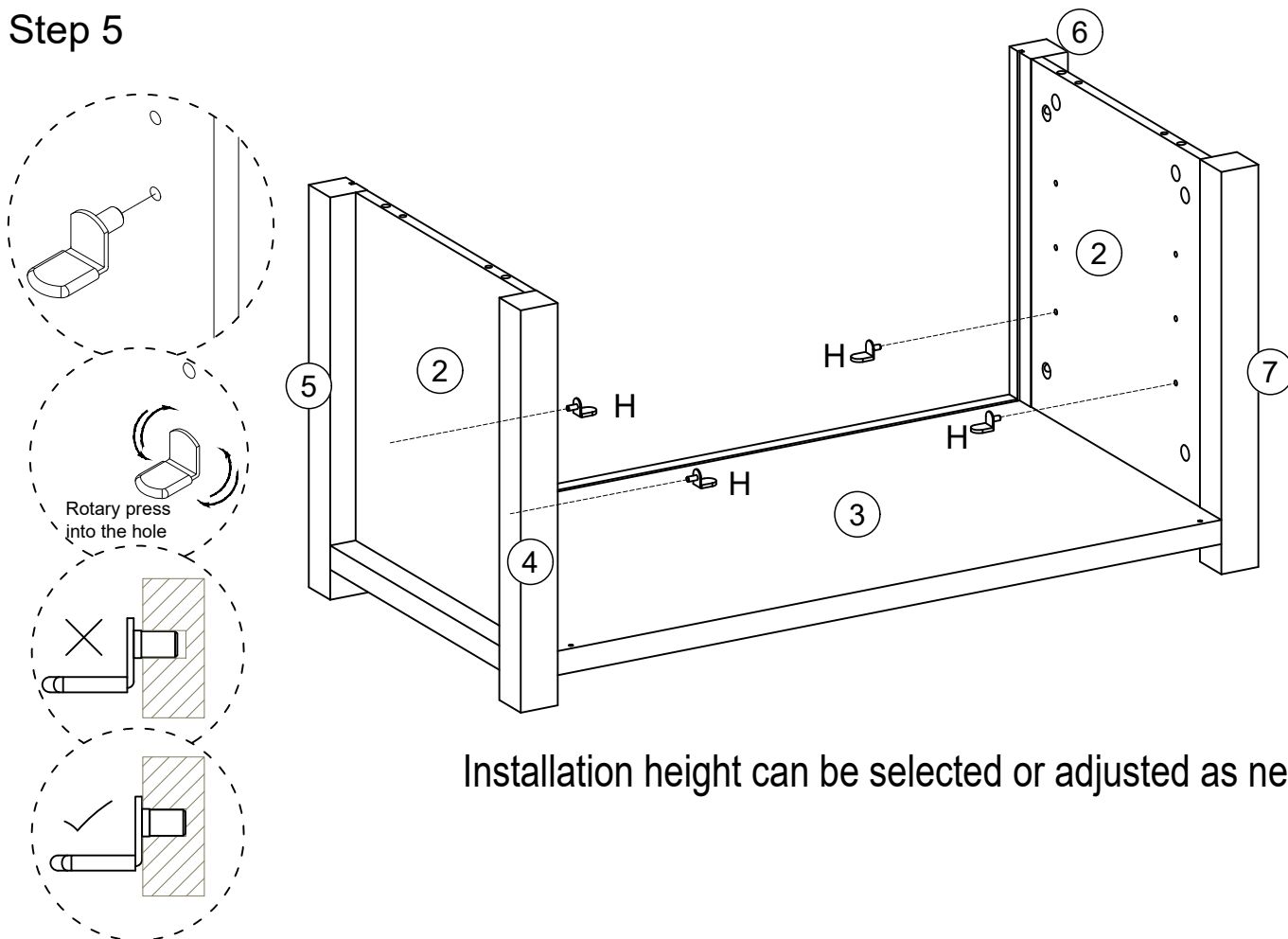

Step 6

The thin plate needs to be fully inserted into the groove. If the insertion is not smooth, you can try pressing from the front or the back to make adjustments until the thin plate is fully inserted into the groove.

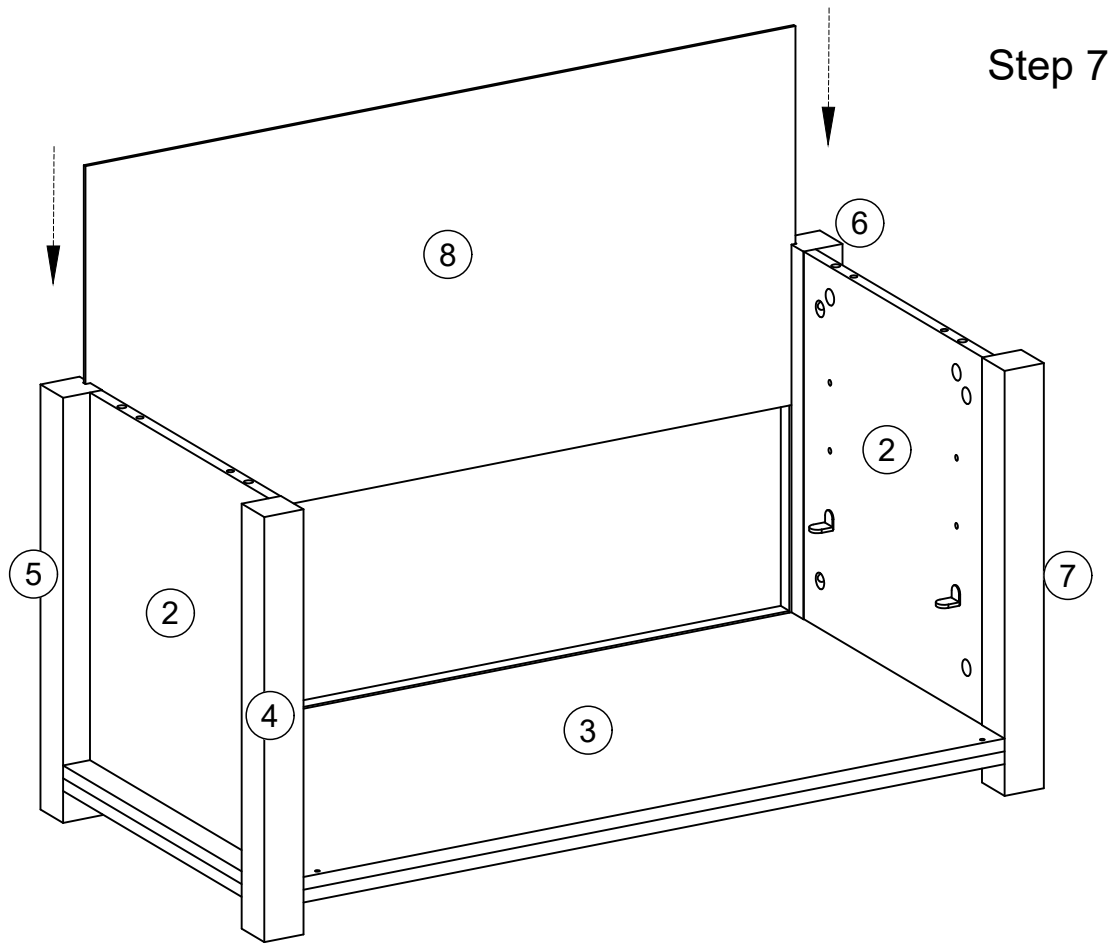

Step 7

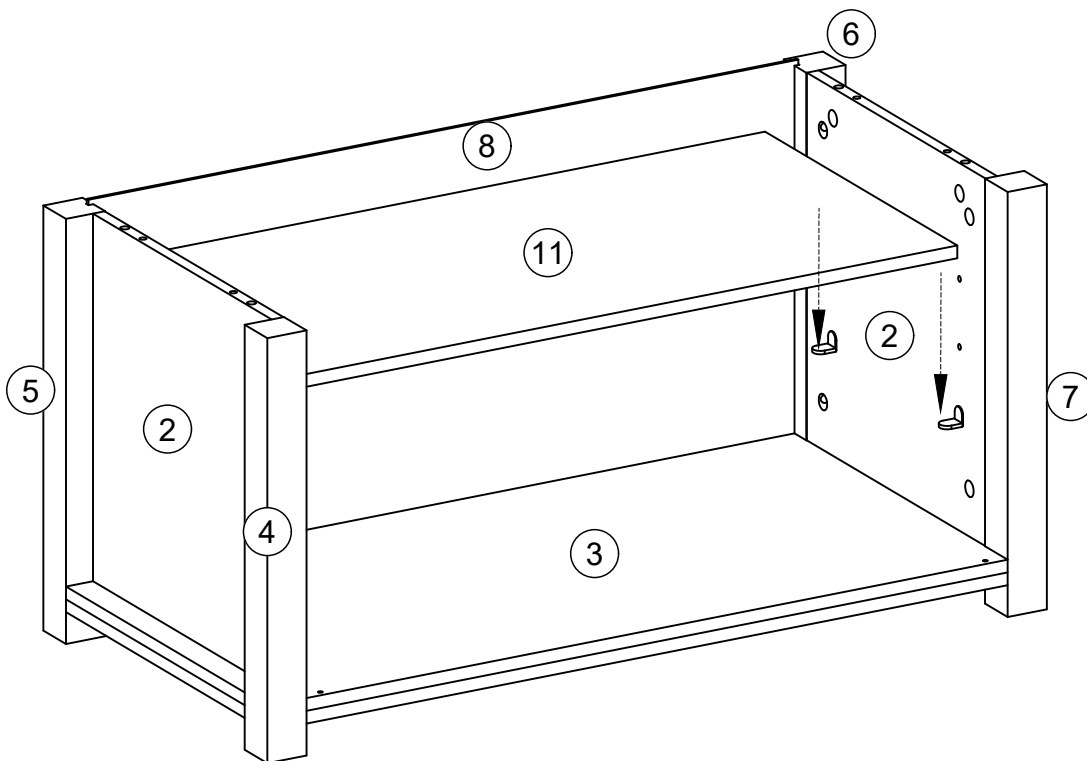

Step 8

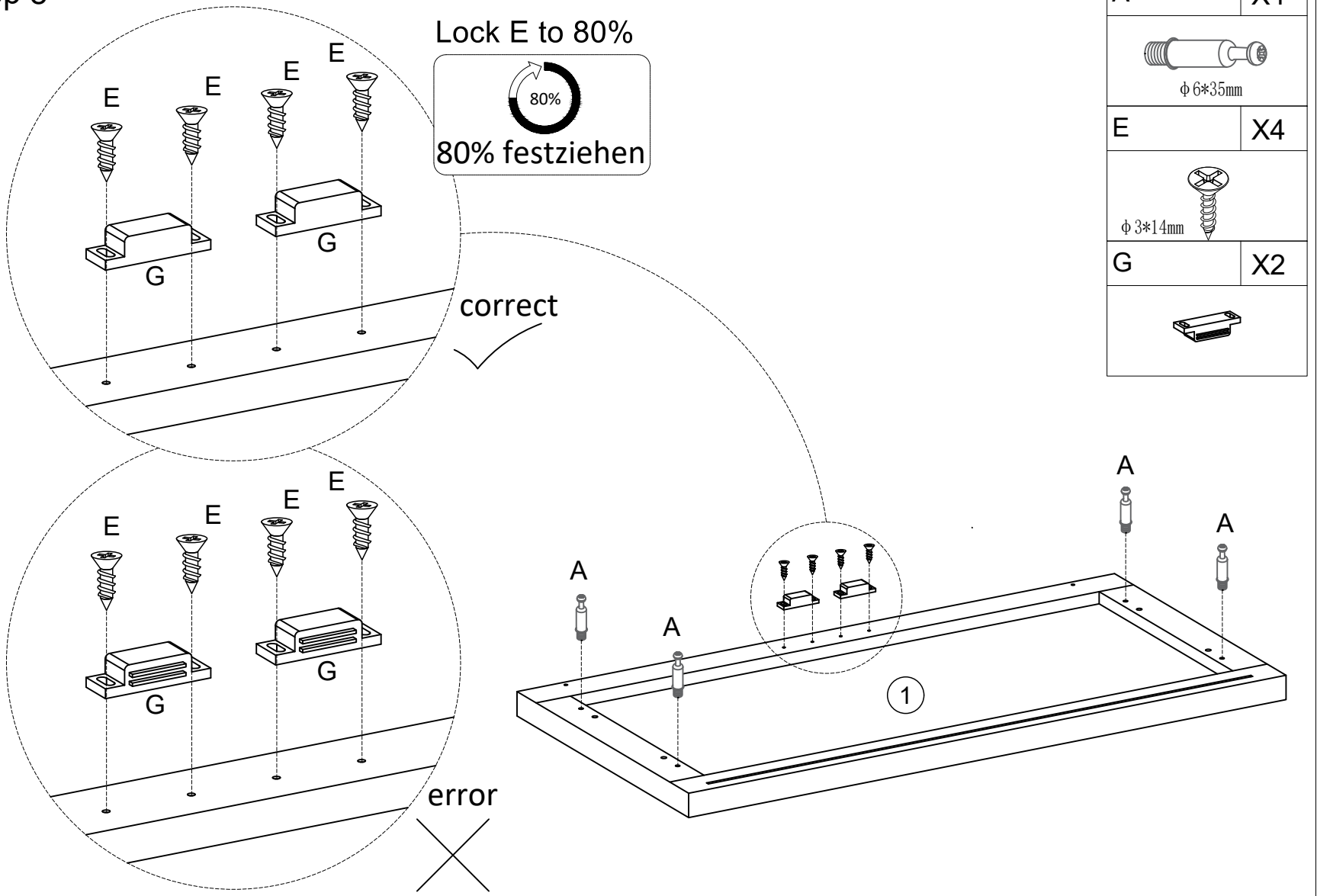

Step 9



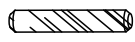

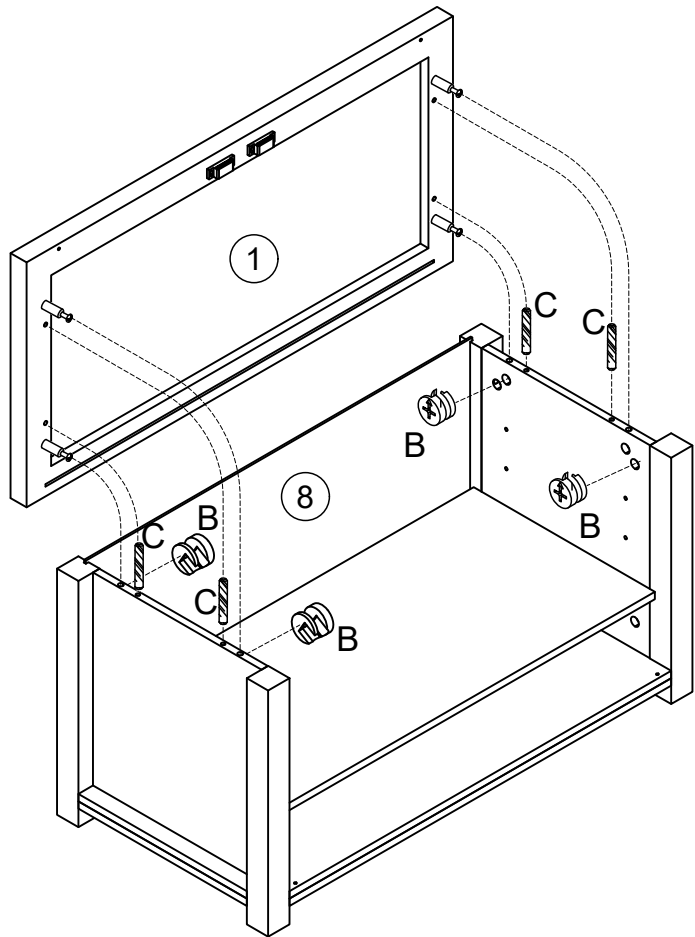
The thin plate needs to be fully inserted into the groove. If the insertion is not smooth, you can try pressing from the front or the back to make adjustments until the thin plate is fully inserted into the groove.

B	X4
	
$\phi 15*10mm$	
C	X4
	
$\phi 6*30mm$	

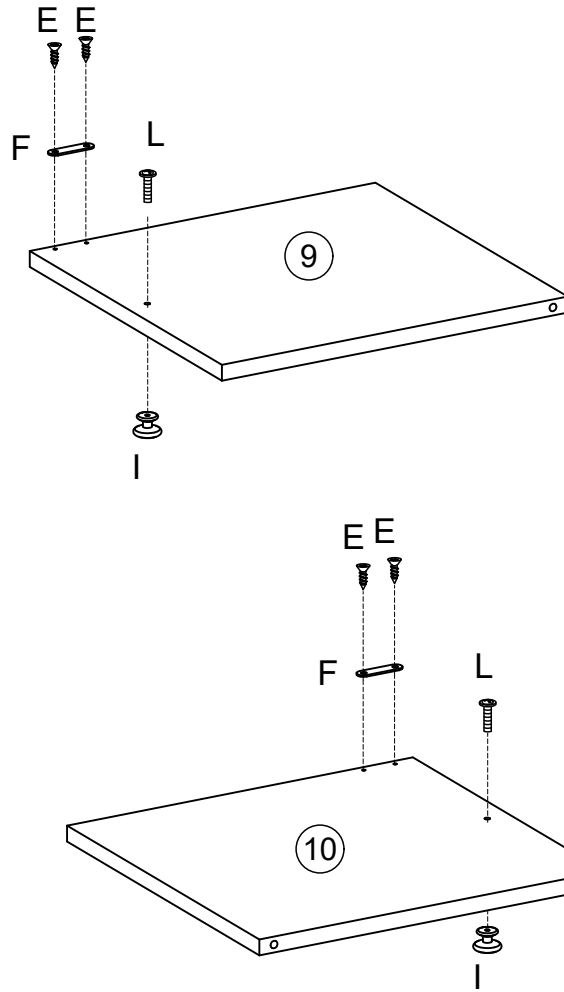

Step 10



E	X4
	
$\phi 3*14mm$	
F	X2
	
I	X2
	
L	X2
	

Step 11

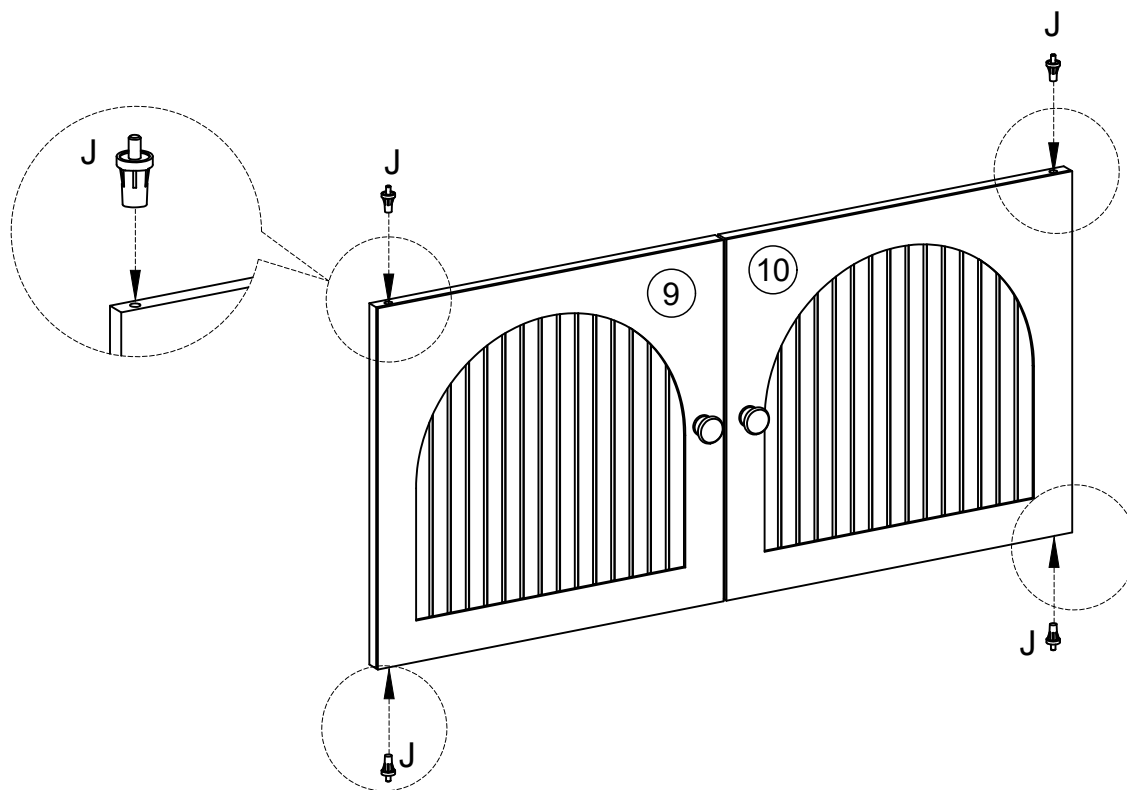

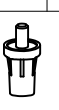
J	X4
	

Step 12

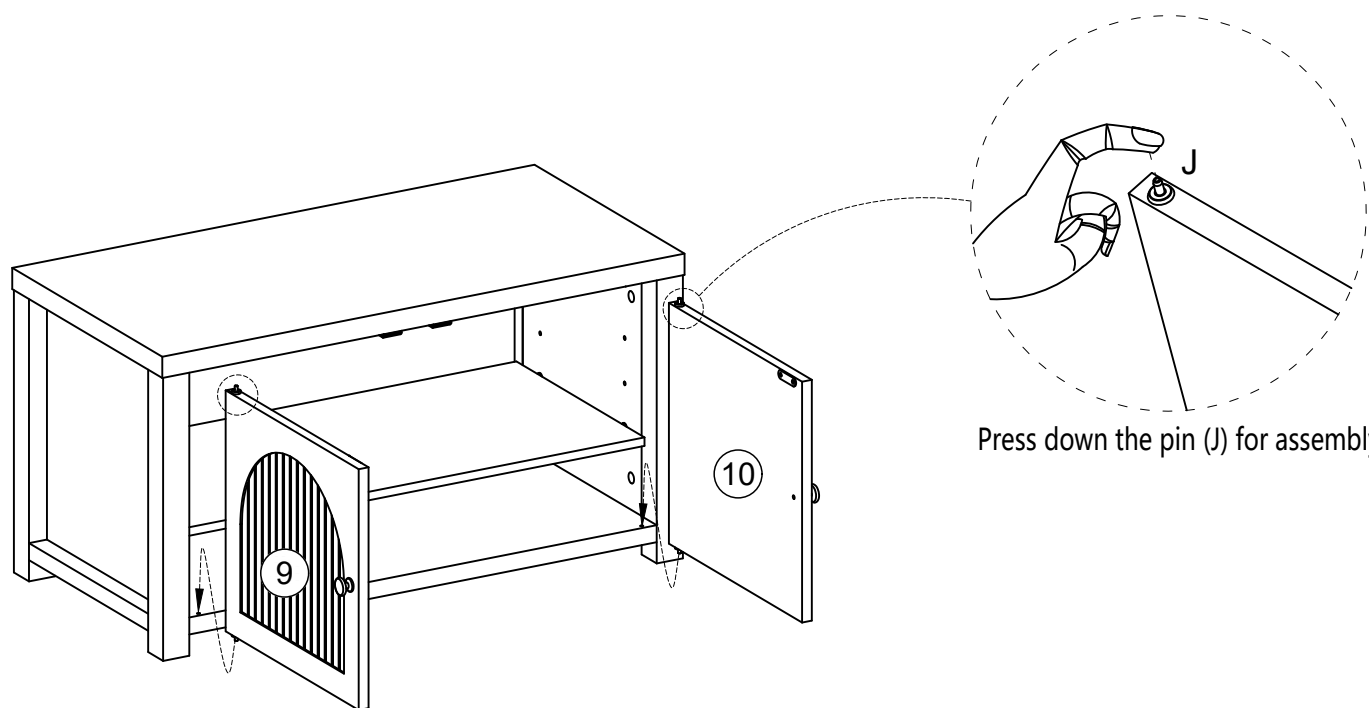

Step 13

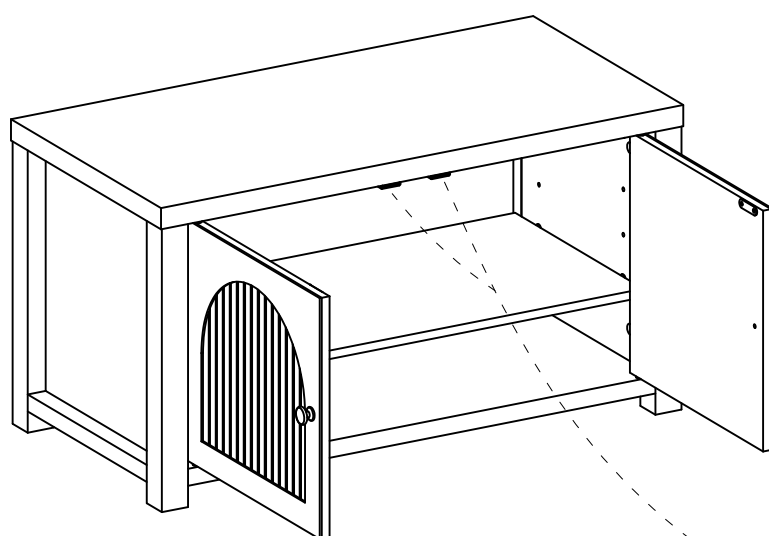

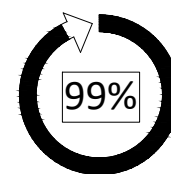

Mounting door panel
Then adjust the position
of the suction door
The door is flat
Before, the last lock
The screws on the door
Suck **E** to 99%



99% festziehen

Step 14

K	X4
	
$\phi 3*16\text{mm}$	

