

ASSEMBLY INSTRUCTIONS

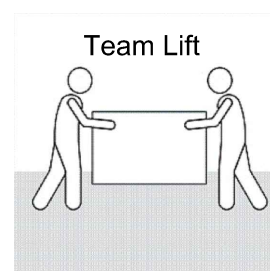

PACKAGE INCLUDE

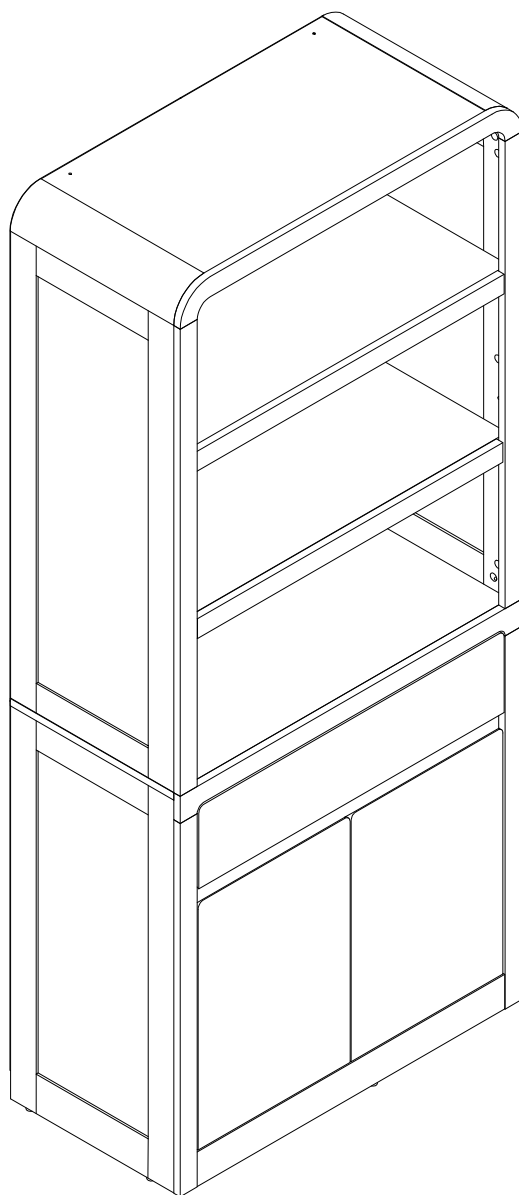

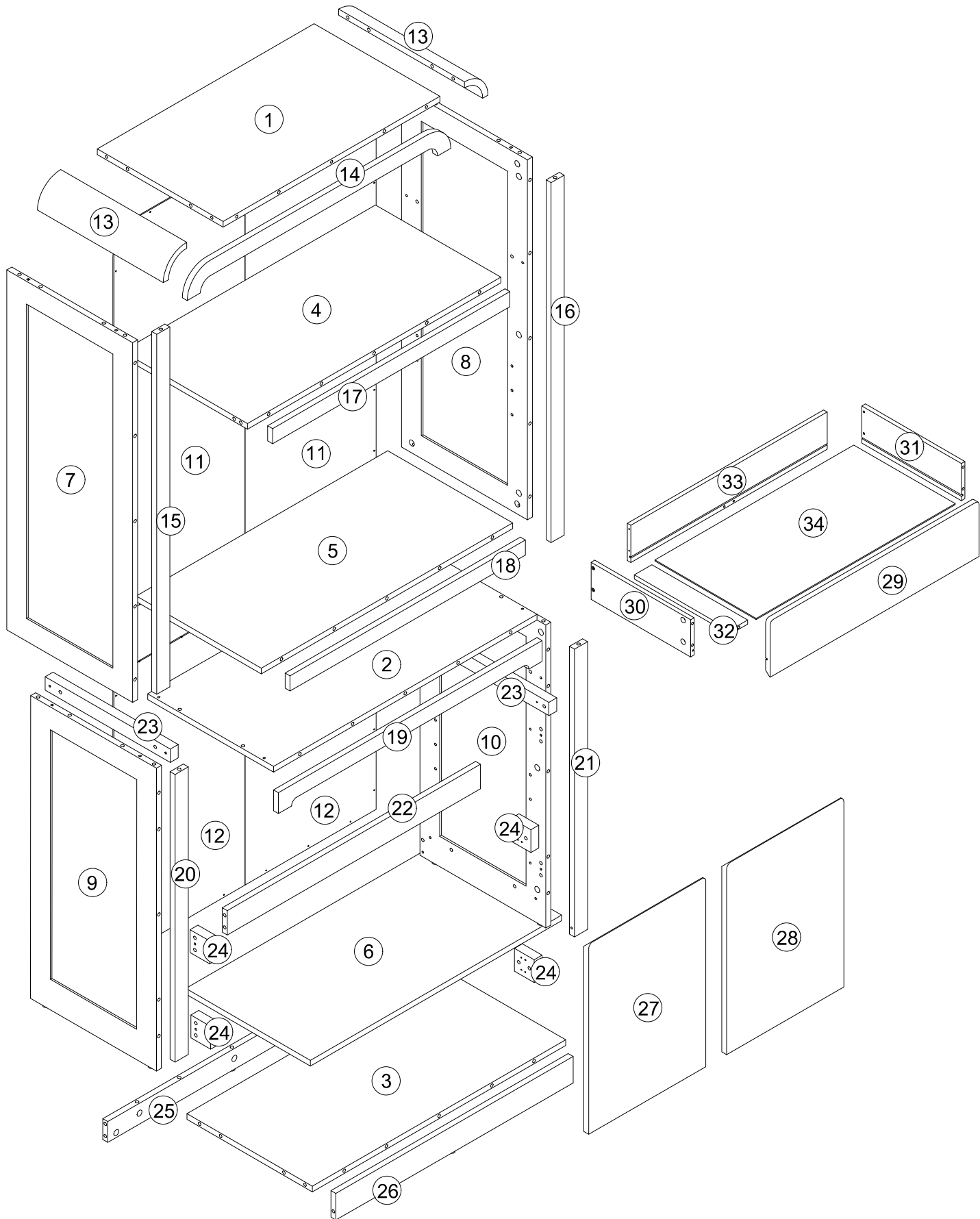





PACKAGE INCLUDE

CODE	DESCRIPTION	QTY
1	Top Tray	1
2	Intermediate Plate	1
3	Base Plate	1
4	Upper Fixed Layer Board	1
5	Upper Movable Layer Board	1
6	Lower Movable Shelf	1
7	Upper Left Side Panel	1
8	Upper Right Side Panel	1
9	Lower Left Side Panel	1
10	Lower Right Side Panel	1
11	Upper Back Panel	2
12	Lower Back Panel	2
13	Arc Component	2
14	Front Upper Trim	1
15	Upper Side Panel Left Trim Strip	1
16	Upper Side Panel Right Trim Strip	1
17	Fixed Shelf Trim Strip	1
18	Upper Adjustable Shelf Trim Strip	1
19	Front Trim Strip Of Middle Panel	1
20	Lower Side Panel Left Trim Strip	1

PACKAGE INCLUDE

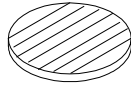
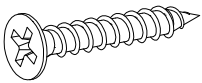
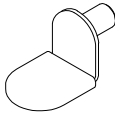
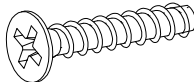
CODE	DESCRIPTION	QTY
21	Right Trim Strip Of Lower Side Panel	1
22	Front Pull Strip	1
23	Sliding Rail Cushion Block	2
24	Door Hinge Pad	4
25	Rear Foot Strap	1
26	Front Foot Strip	1
27	Left Door Panel	1
28	Right Door Panel	1
29	Drawer Panel Removal	1
30	Left-hand Drawer	1
31	Right-hand Drawer	1
32	Drawer Pull Strip	1
33	Drawer End Panel	1
34	Drawer Bottom	1

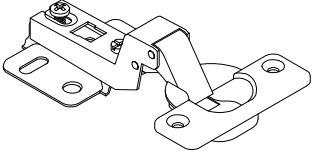
PACKAGE CONTENT

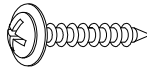
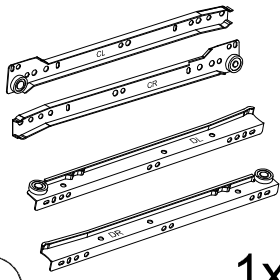
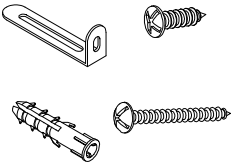
<p>L=25MM</p>  <p>A 65x+6</p>	<p>Ø15x9MM</p>  <p>B 65x+6</p>	<p>Ø8x30MM</p>  <p>C 64x+6</p>	<p>Ø23MM</p>  <p>D 65x+6</p>
<p>Ø4x30MM</p>  <p>E 6x</p>	<p>Ø6x(20x16)MM</p>  <p>F 8x</p>	<p>Ø5x35MM</p>  <p>G 12x+1</p>	<p>Ø3.5x12MM</p>  <p>H 12x+1</p>
<p>Ø35MM</p>  <p>I 4x</p>	<p>Ø3.5x14MM</p>  <p>J 24x+2</p>	<p>Ø3x15MM</p>  <p>K 42x+4</p>	 <p>L 1x</p>
 <p>M 2x</p>			

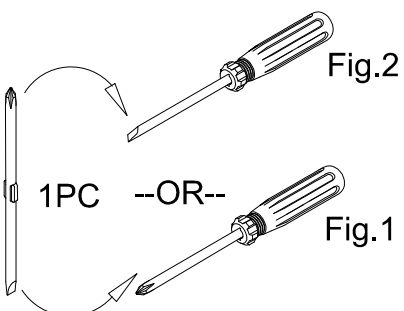

How to use the cam lock system

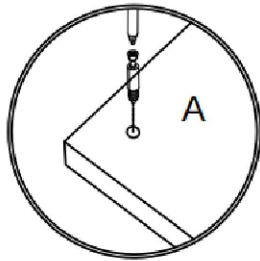

1. Screw cam bolt into panel

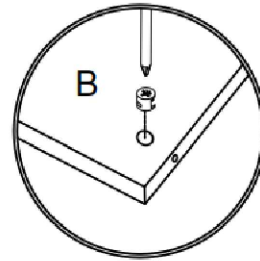

2. Push cam into panel - arrow feature on cam top points to panel edge

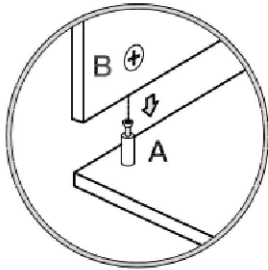

3. Align cam bolt(s) with cam(s) and insert all the way into cross-bored hole(s)

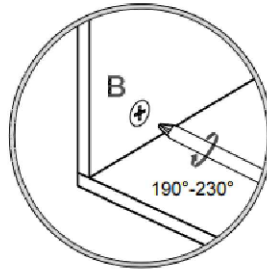

4. Rotate cam(s) clockwise 190°-230° to lock panels together

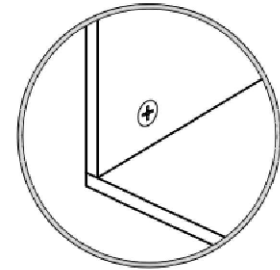

5. Panels should be tight against each other and connection should be rigid

Insert the wood dowel (C) at least half way by tapping lightly with a rubber mallet, IT NECESSARY.

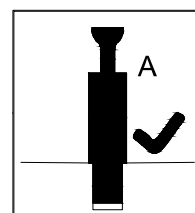
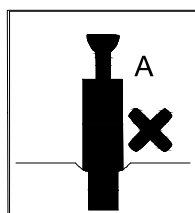
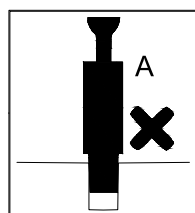
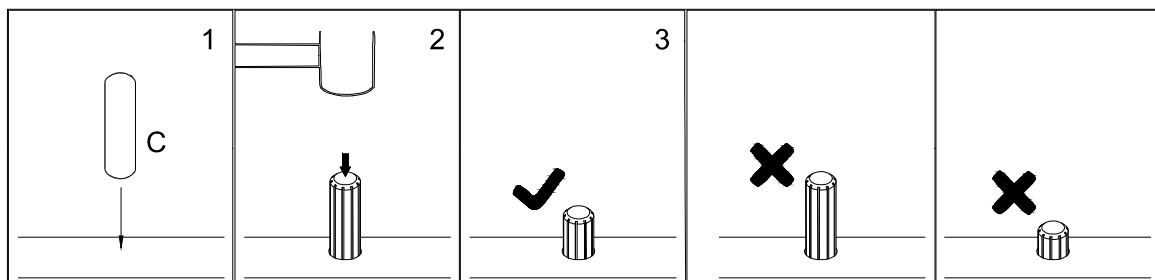

WARNING

- Unit must be placed on a level surface or leveled with included hardware (when applicable).
- Do not sit or stand on or allow children to climb, sit or stand on the assembled product.
- For safety reasons, it is imperative that this unit be mounted to the wall.
- Do not use without installing the tip restraint.
- Unit can tip over causing severe injury or death.
- Do not exceed the recommended weight limits.
- Evenly distribute the weight on each level and always keep the heavier loads on the bottom.
- Before cutting, drilling or hammering into any wall or floor surface, verify the location of electrical, plumbing and gas lines. Cutting may cause serious injury.

STEP 1

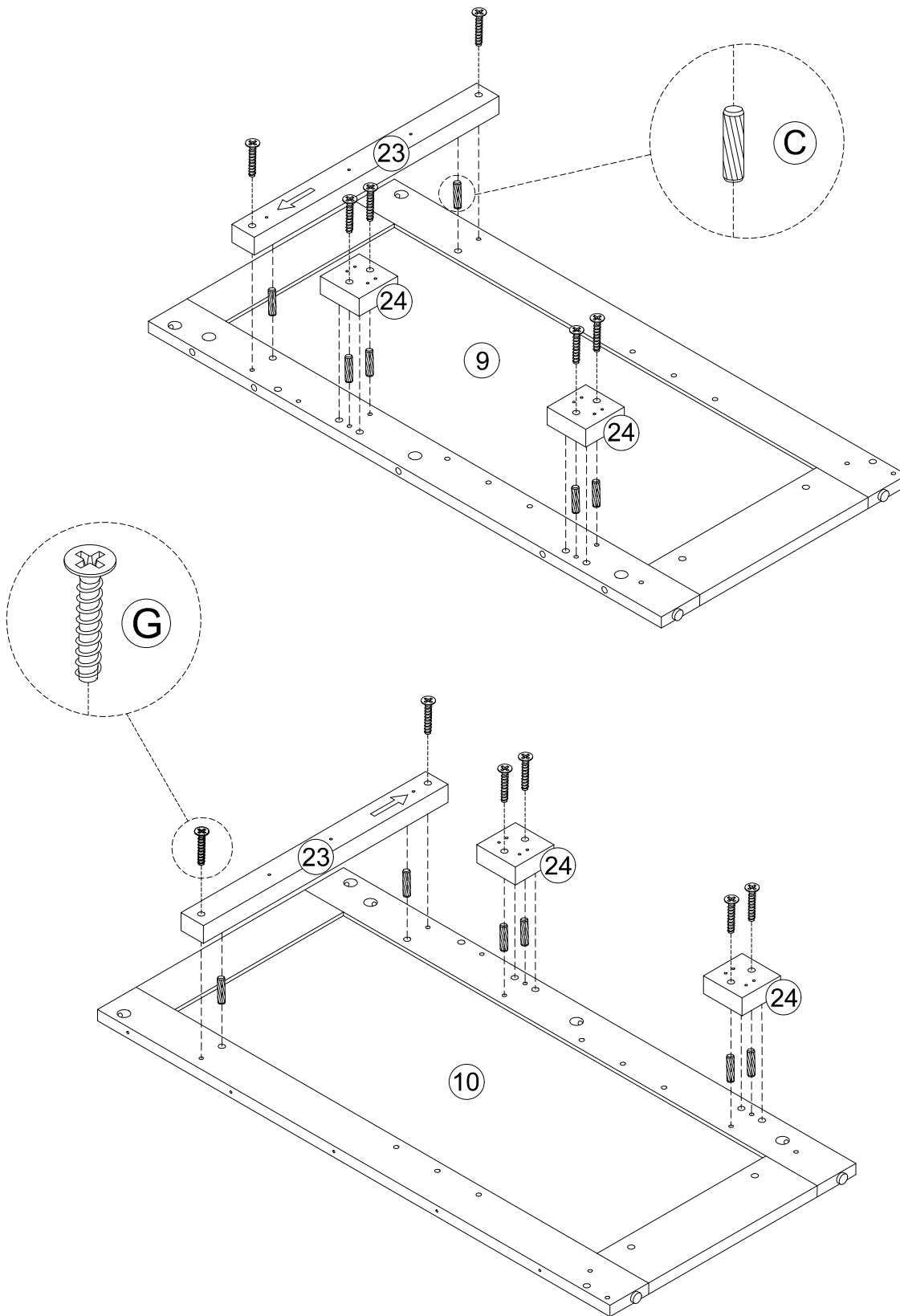
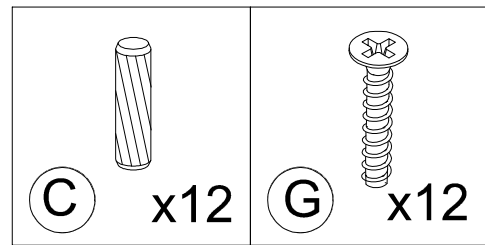

STEP 2

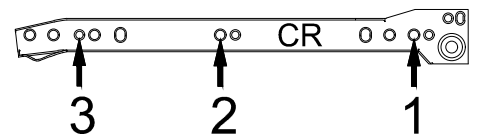
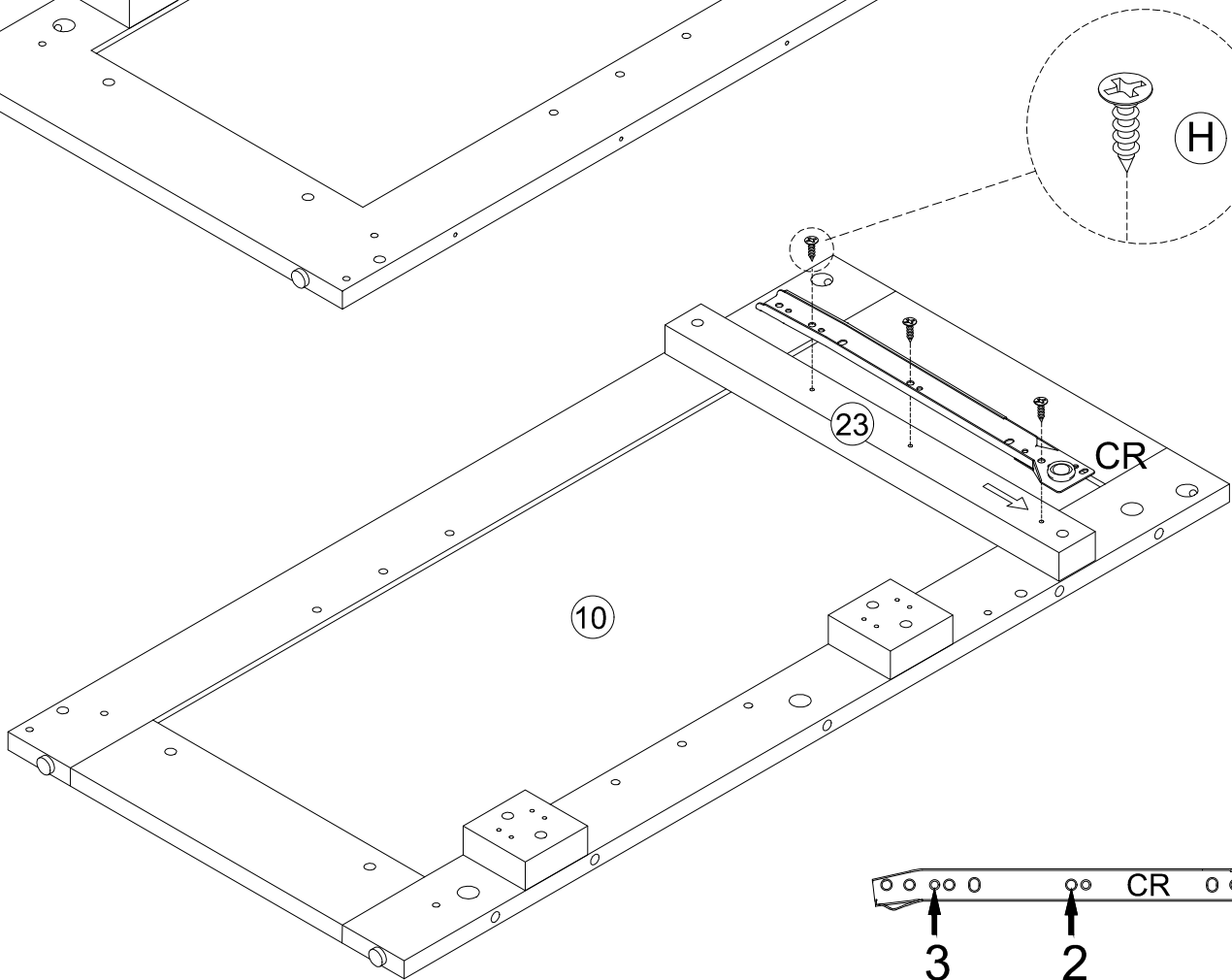
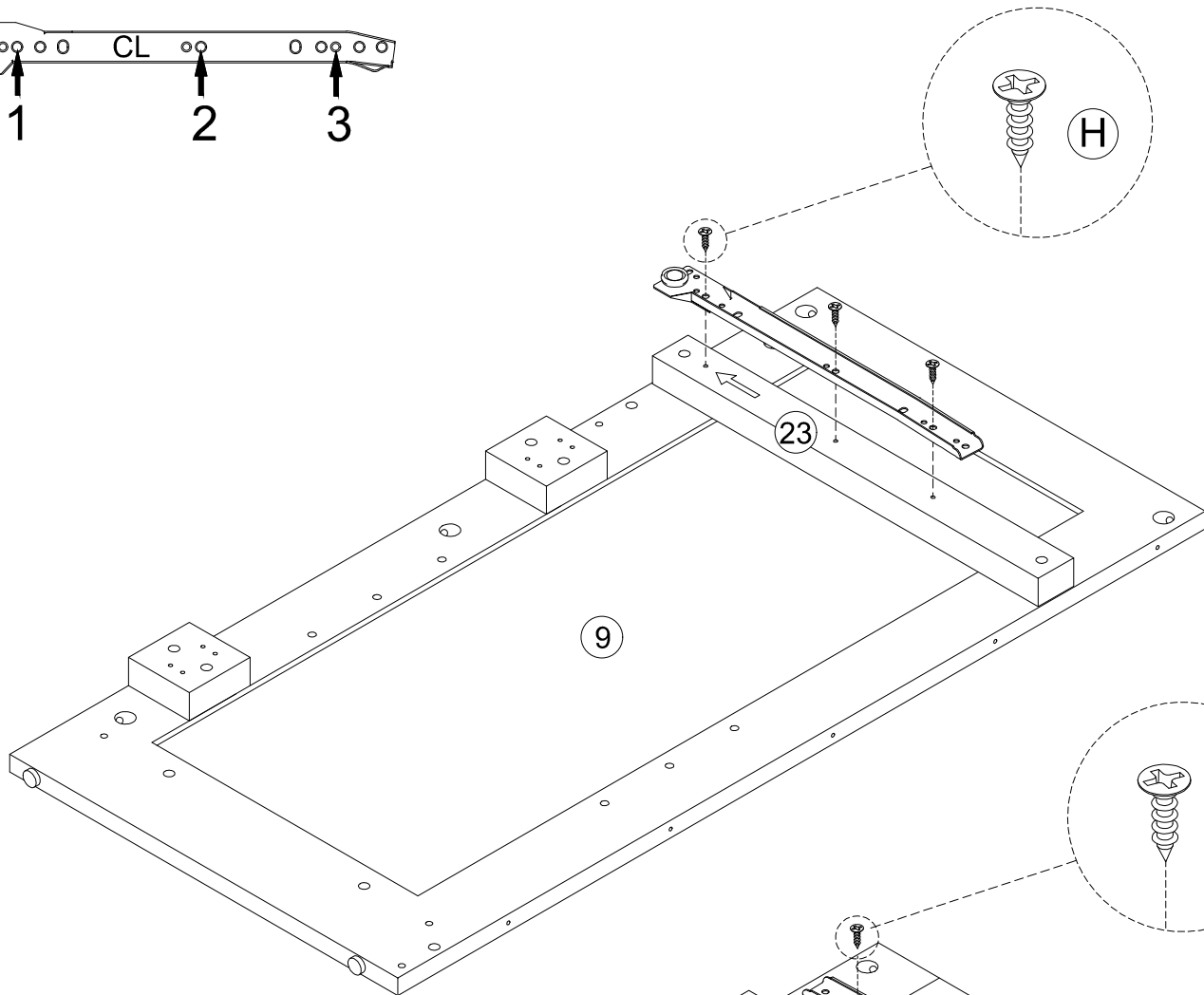
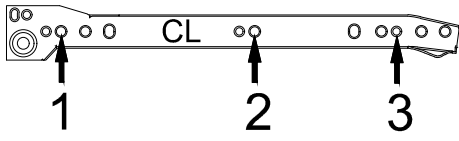
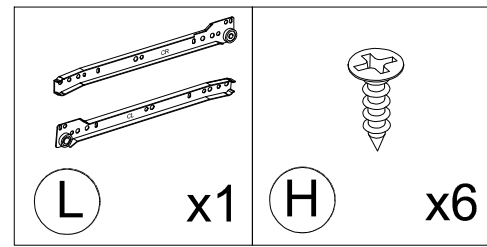

STEP 3

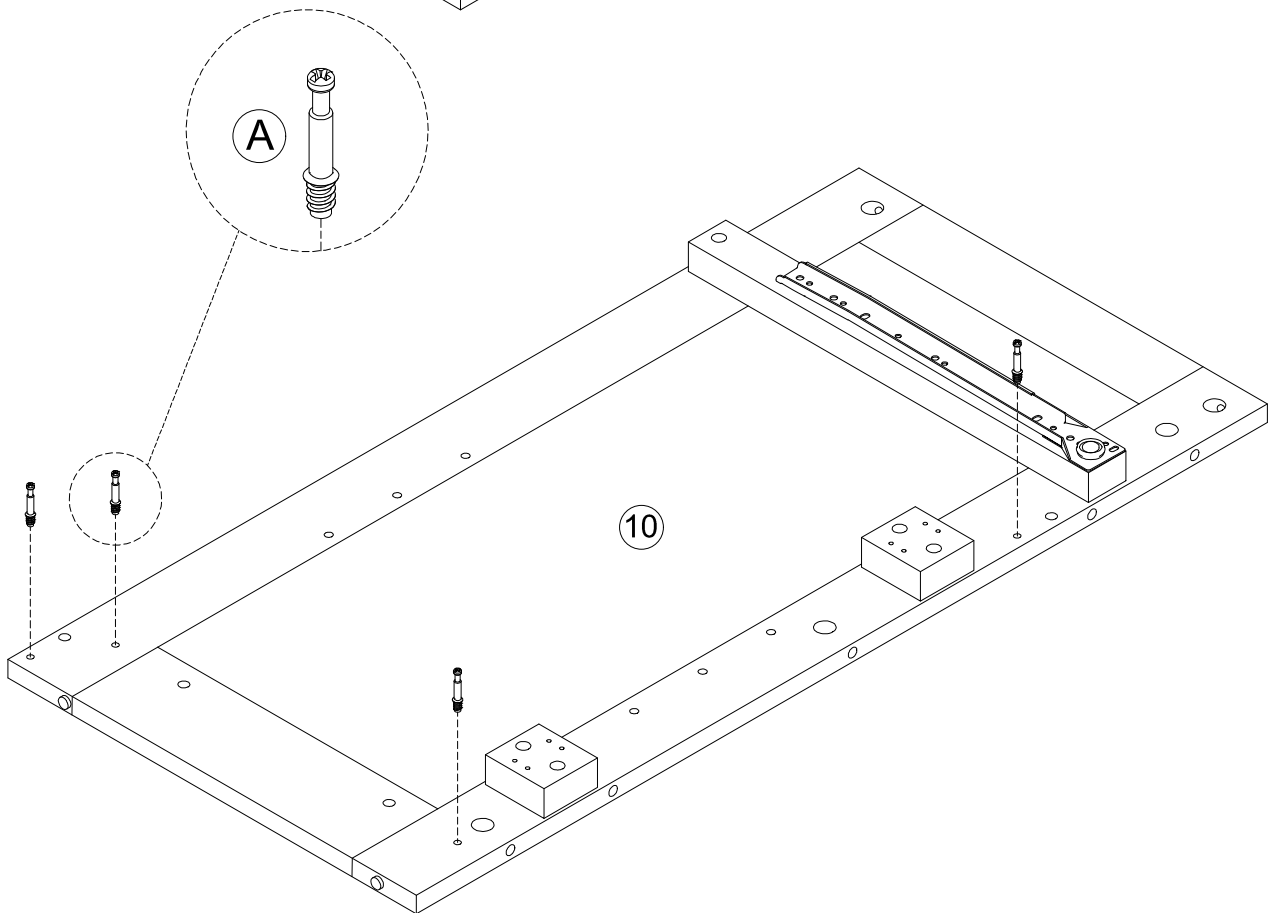
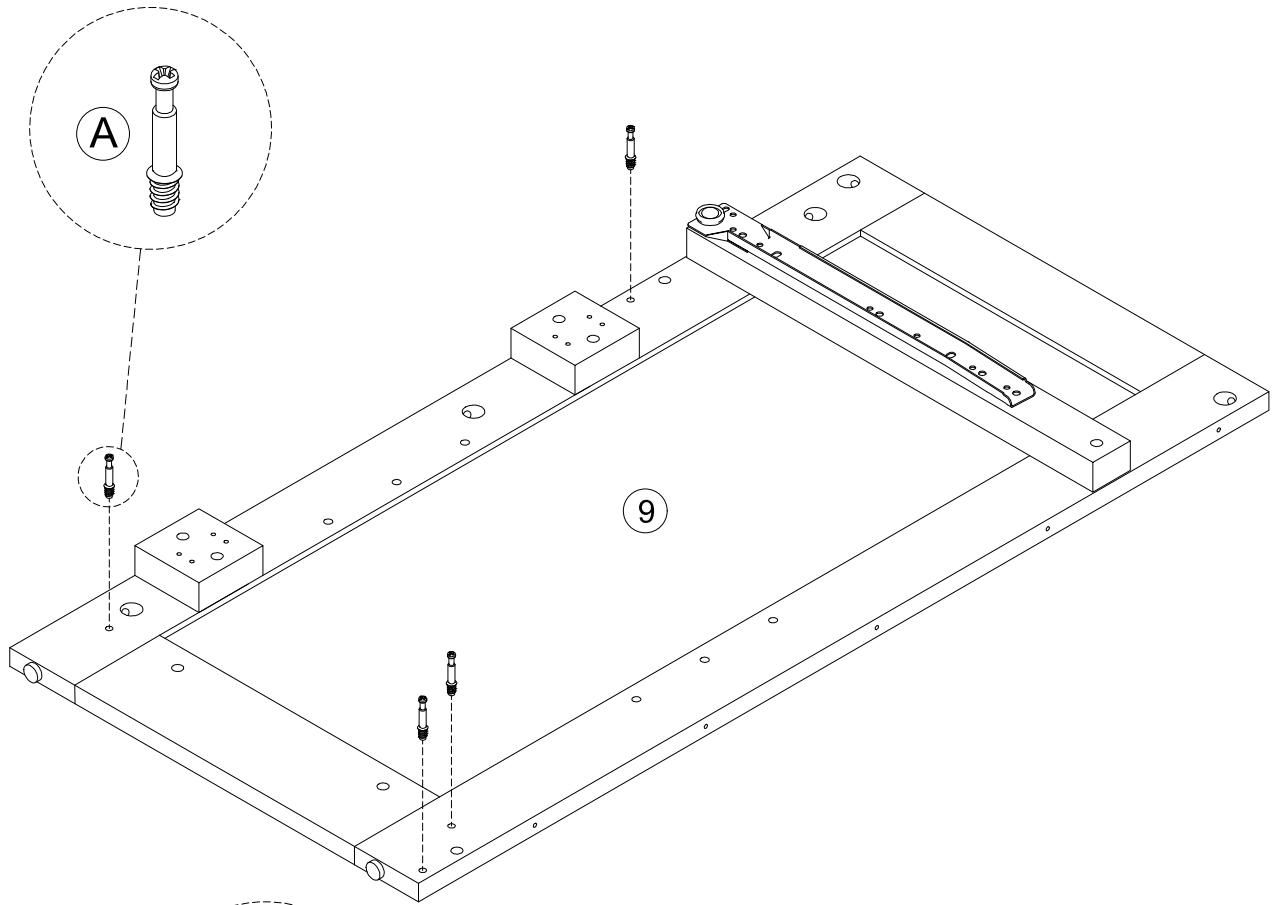
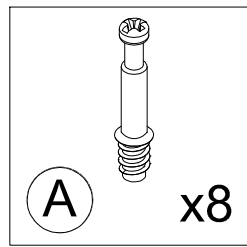

STEP 4

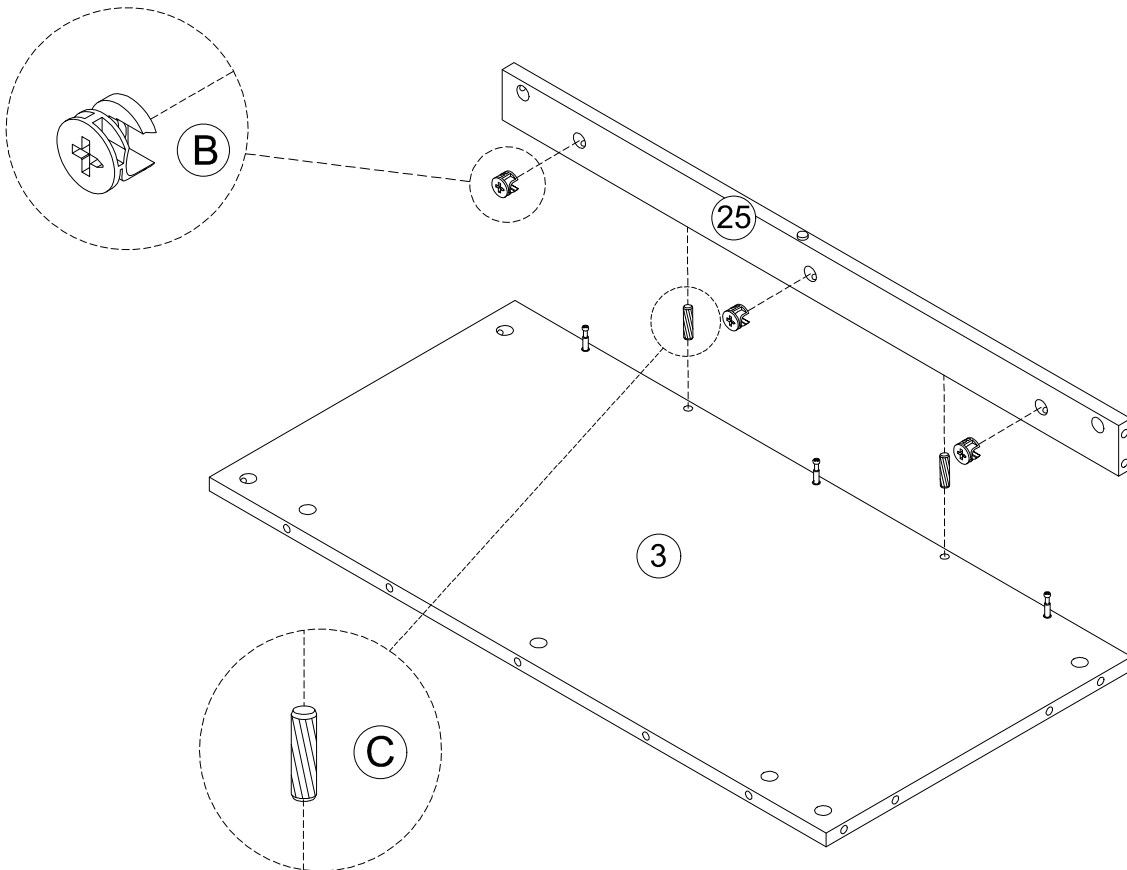
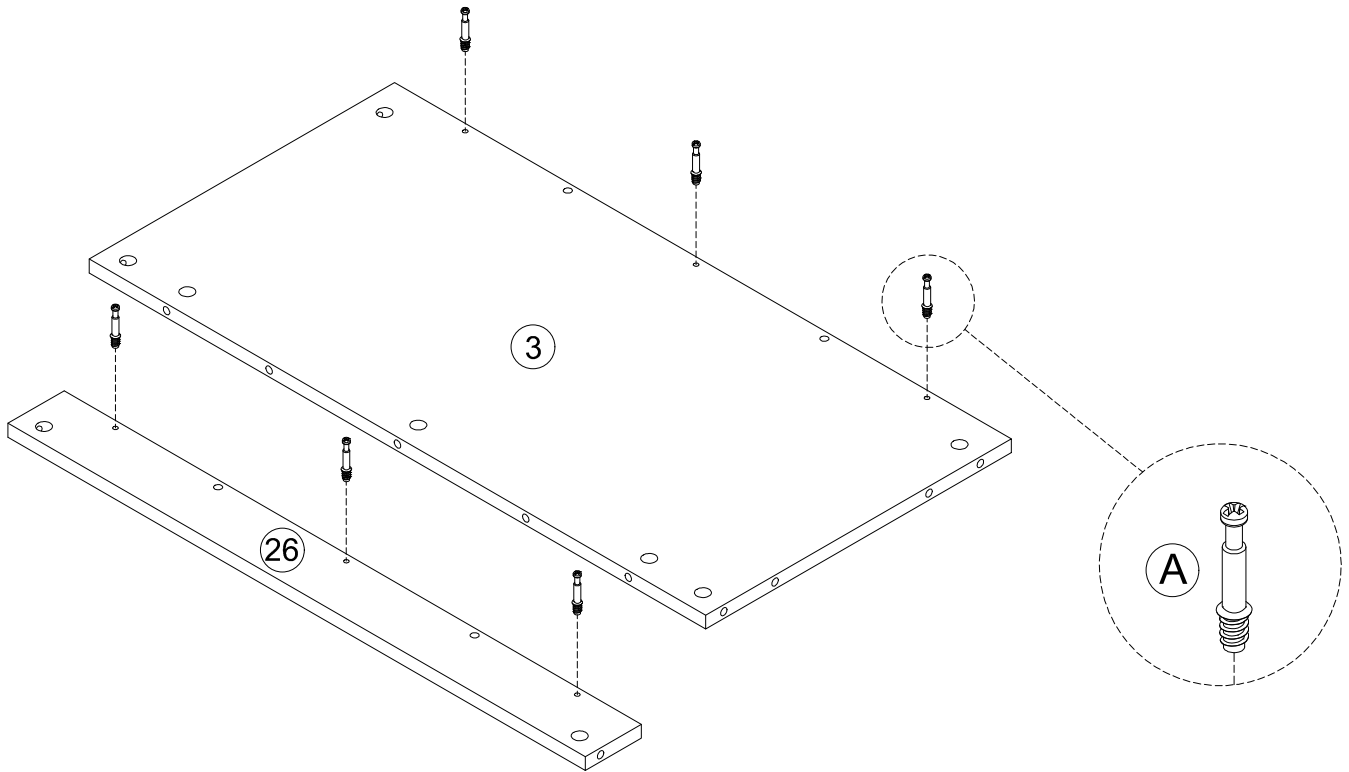
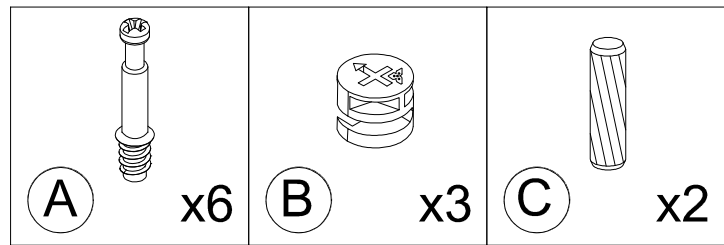

STEP 5

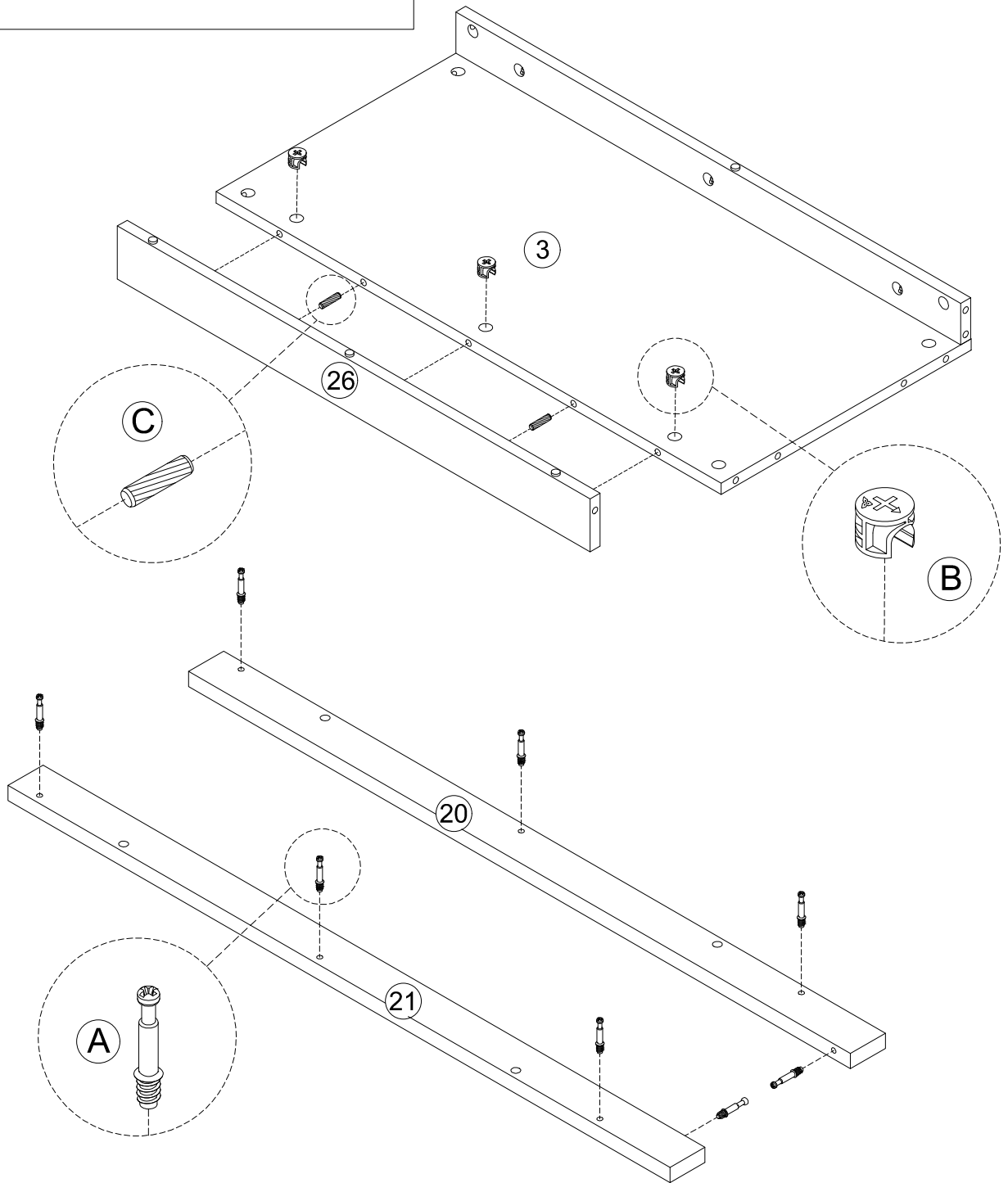
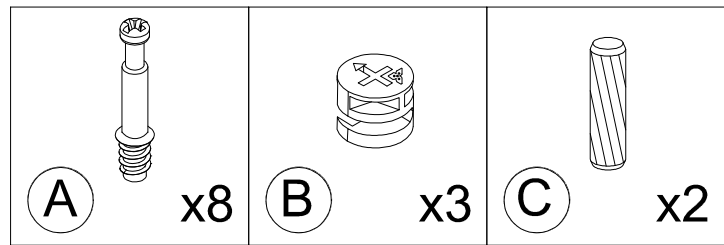
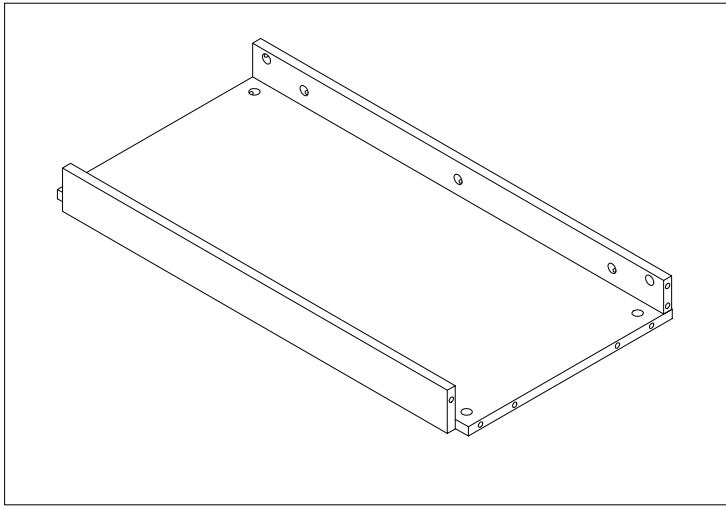

STEP 6

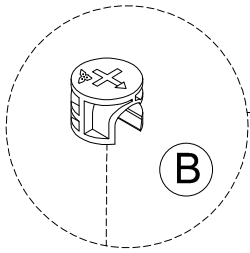
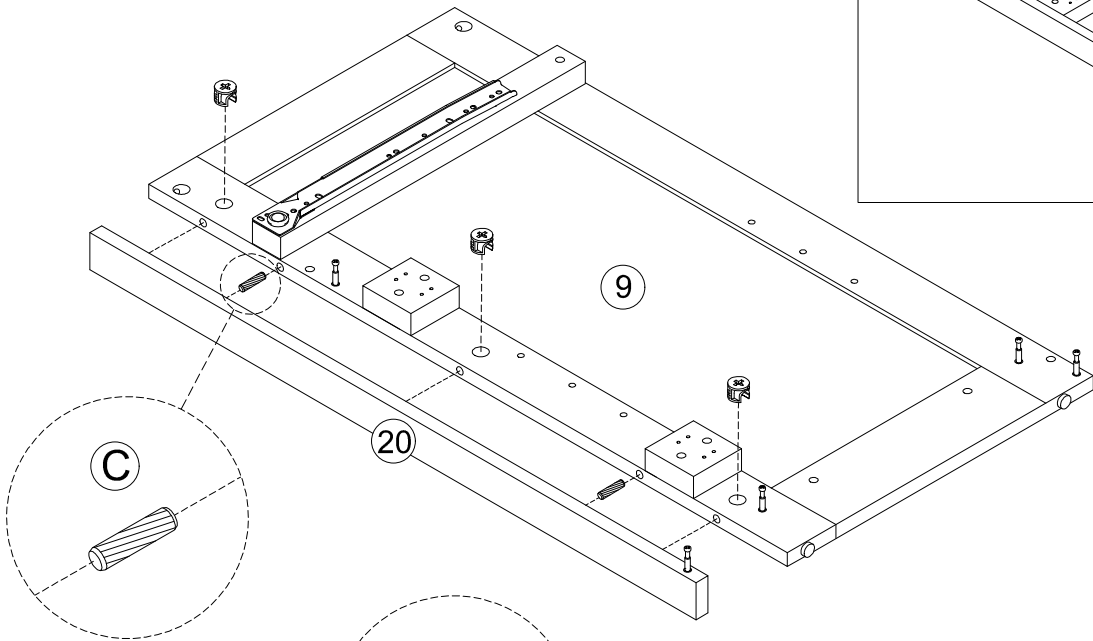
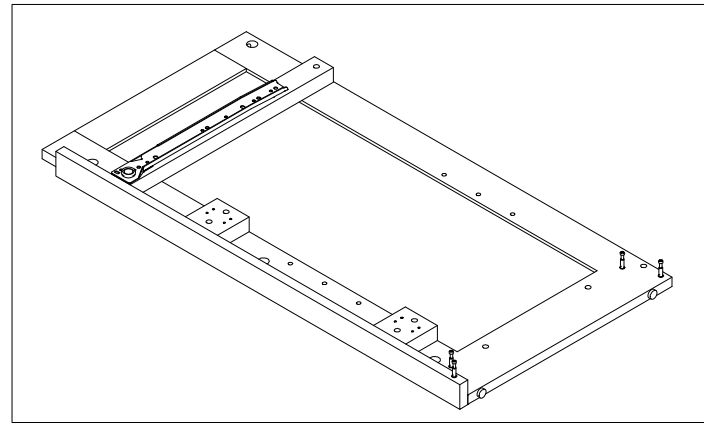
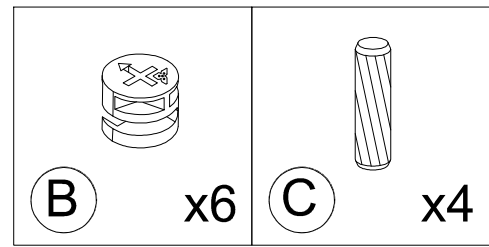

B

20

9

21

10

21

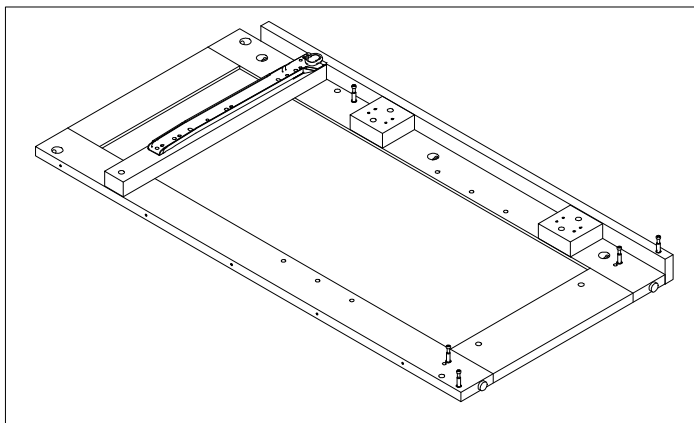

10

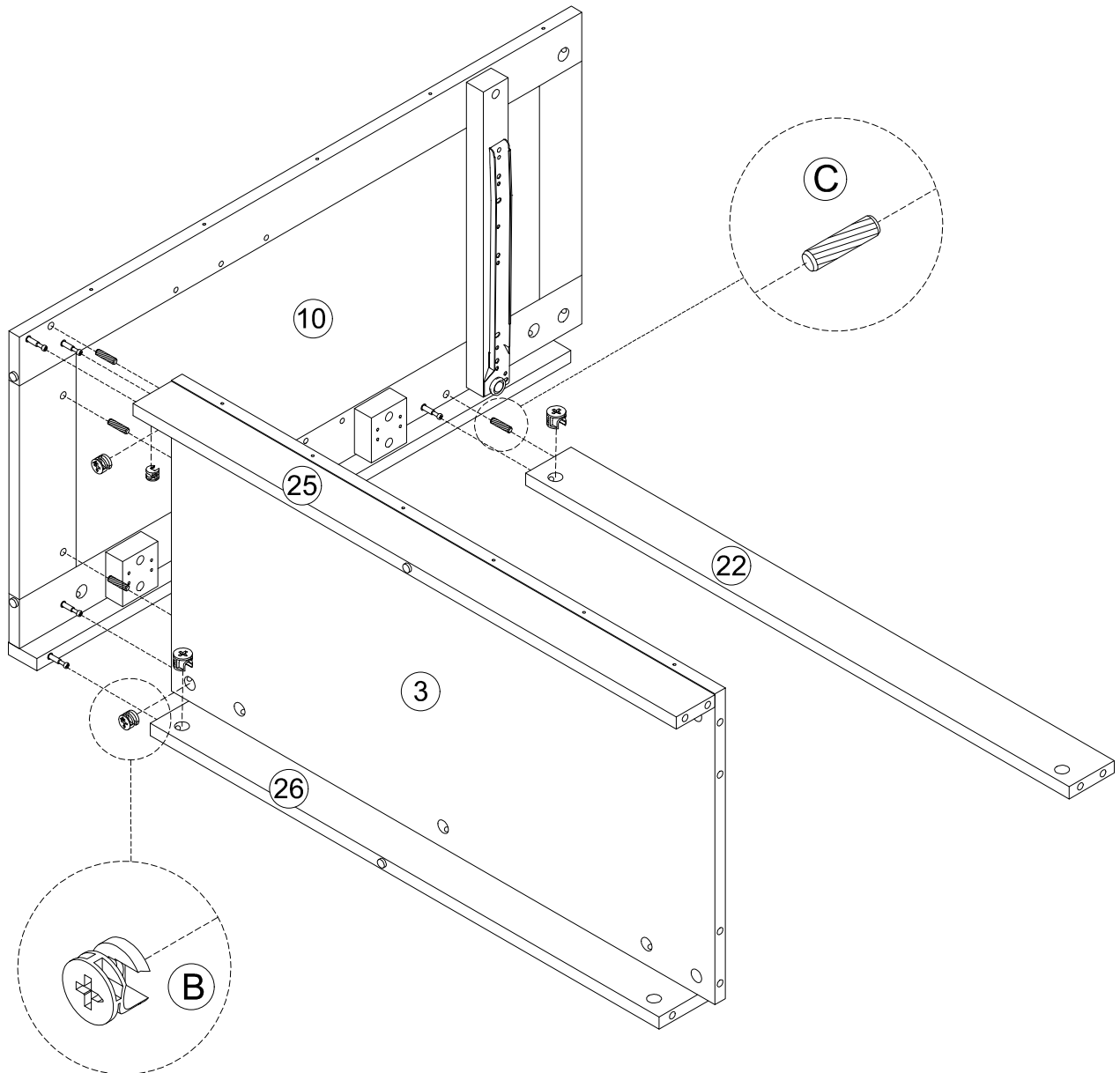
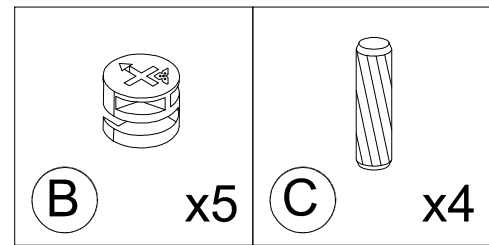
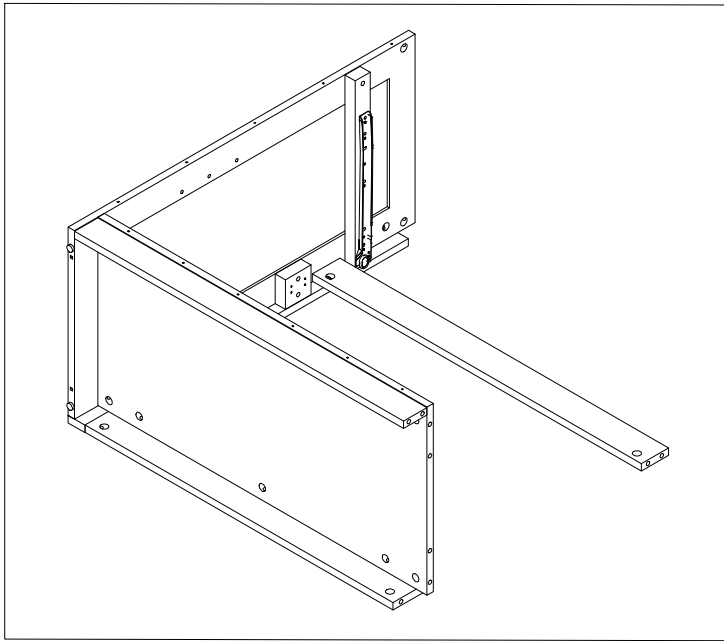

STEP 7



STEP 8

	
(B) x5	(C) x4

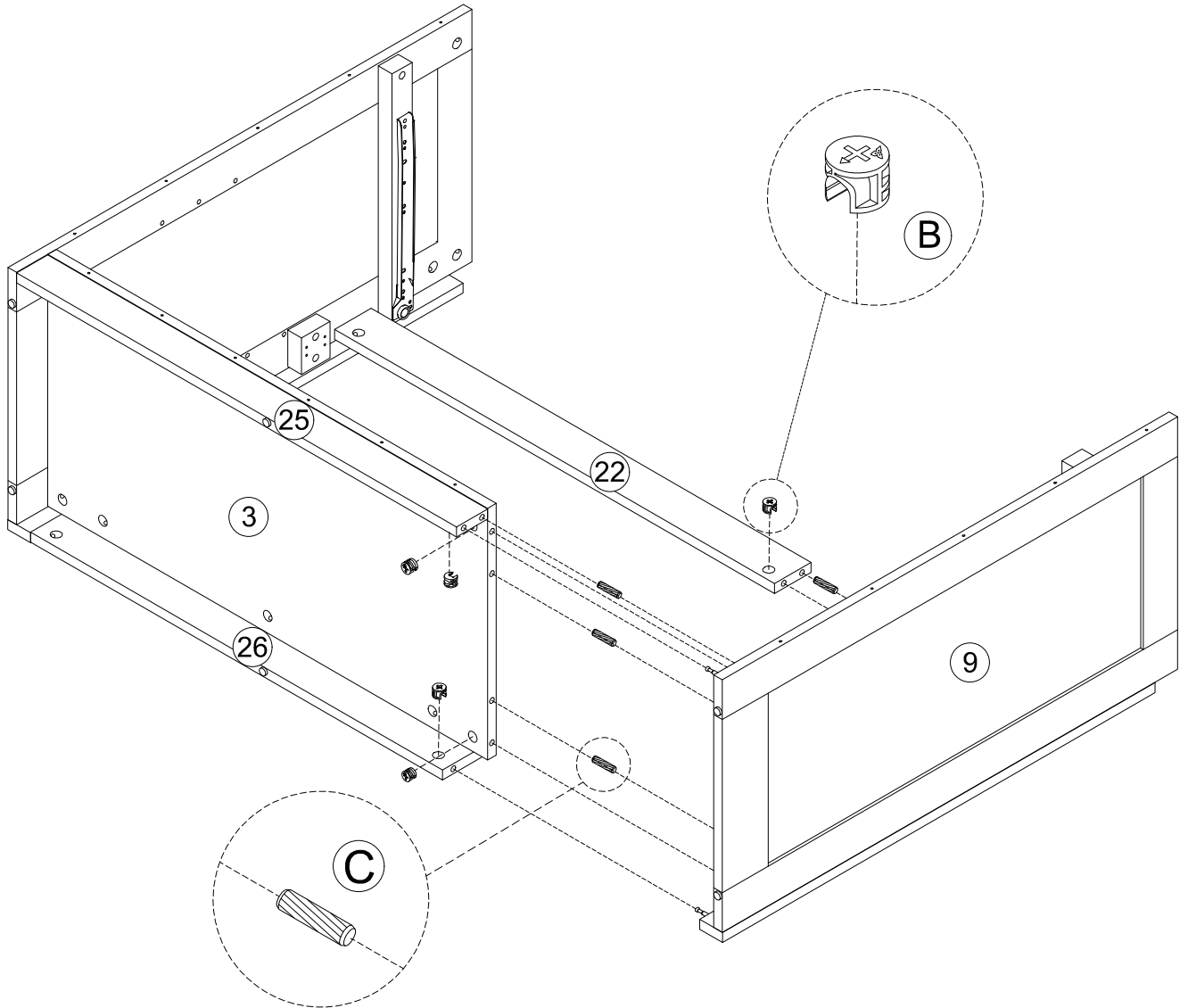
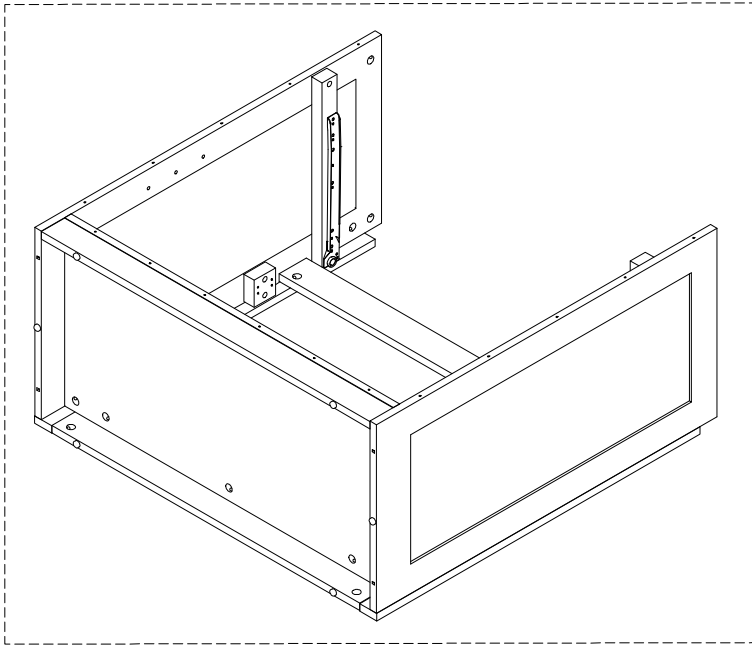

STEP 9

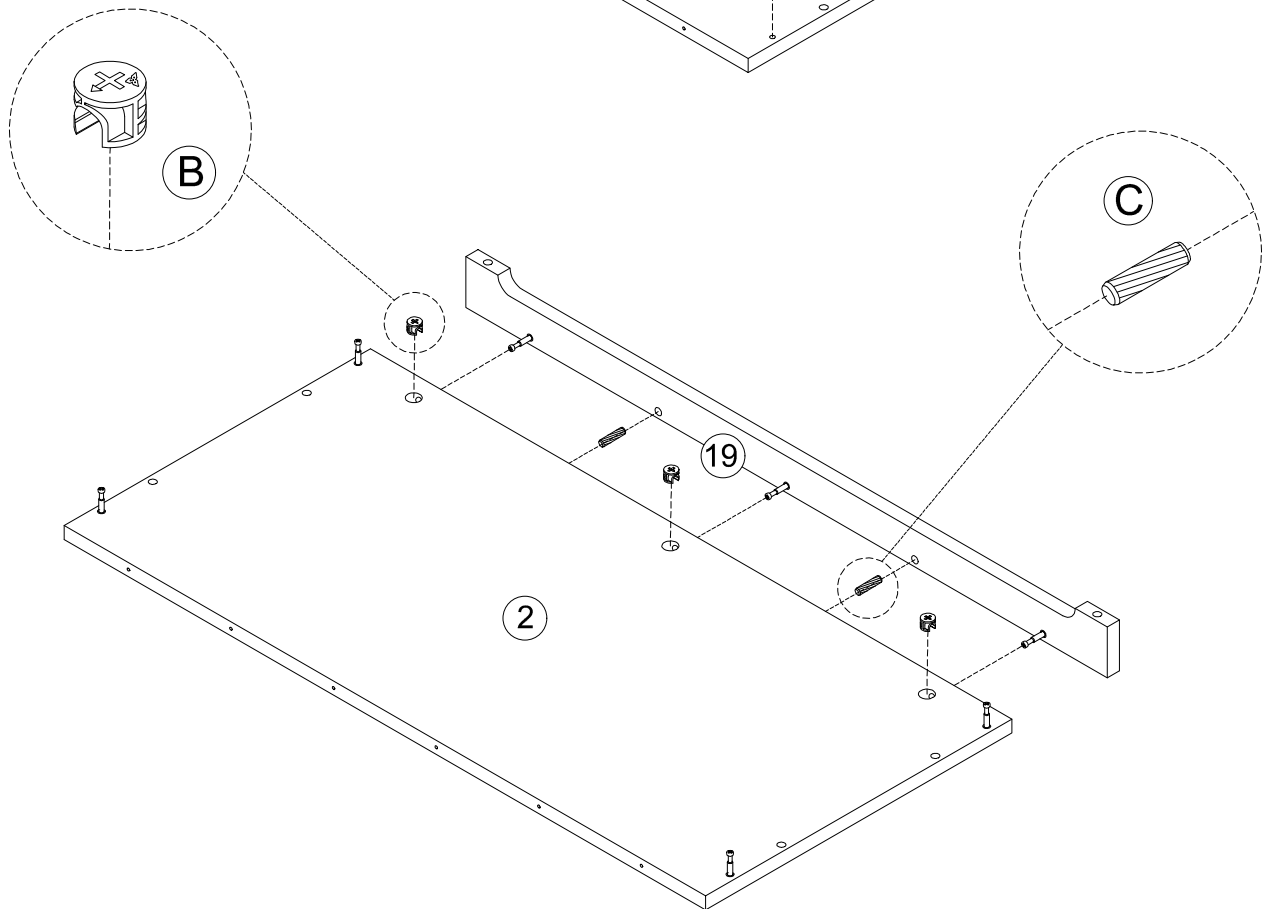
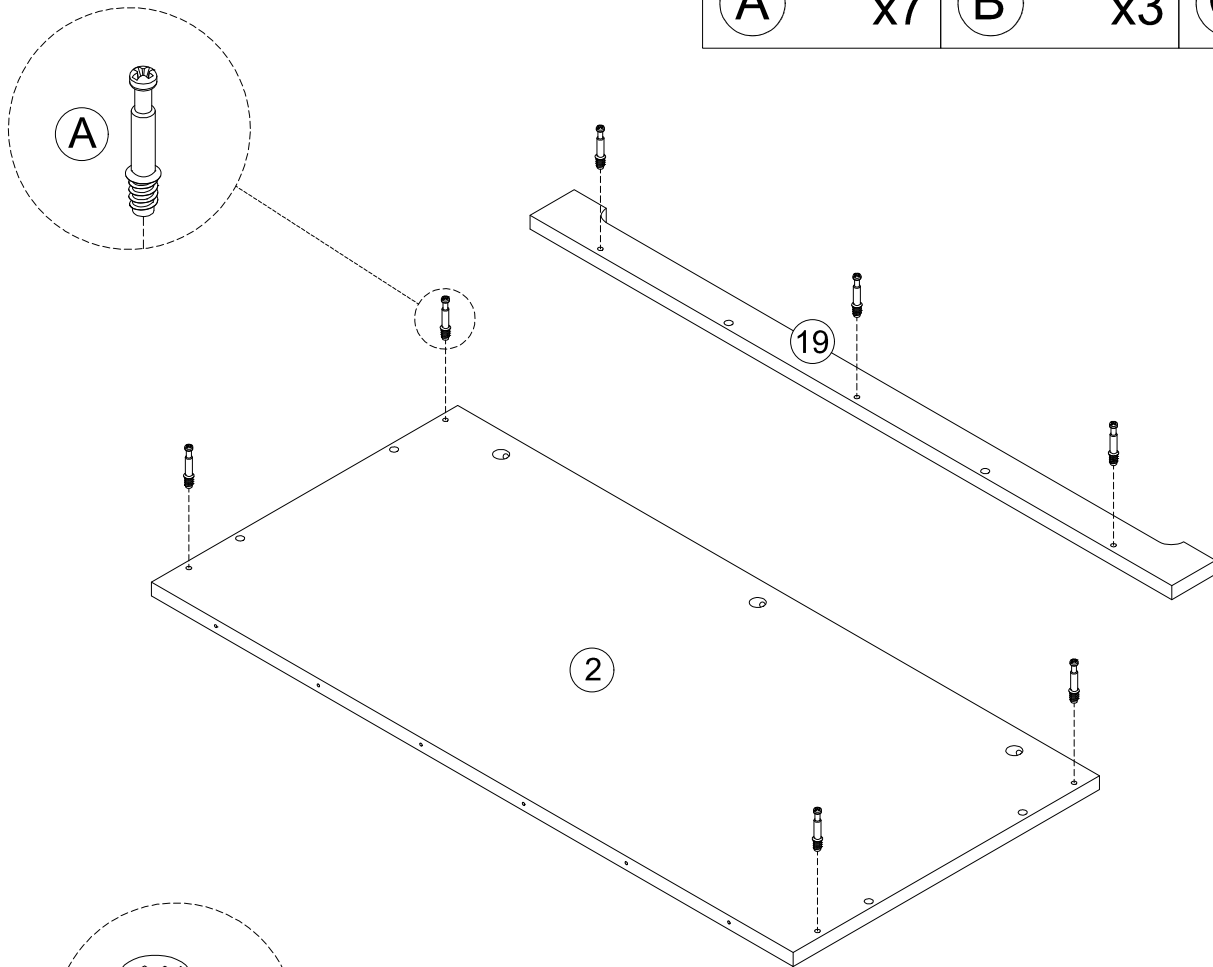
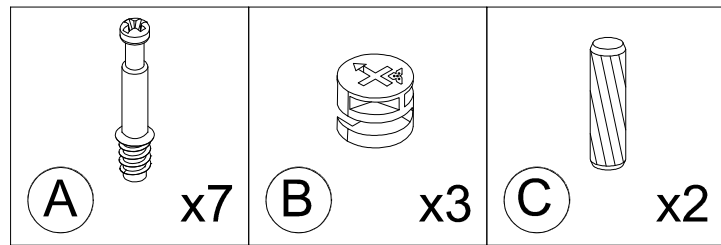

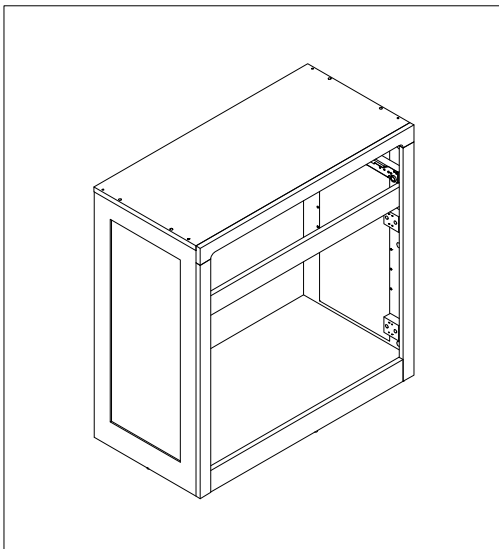
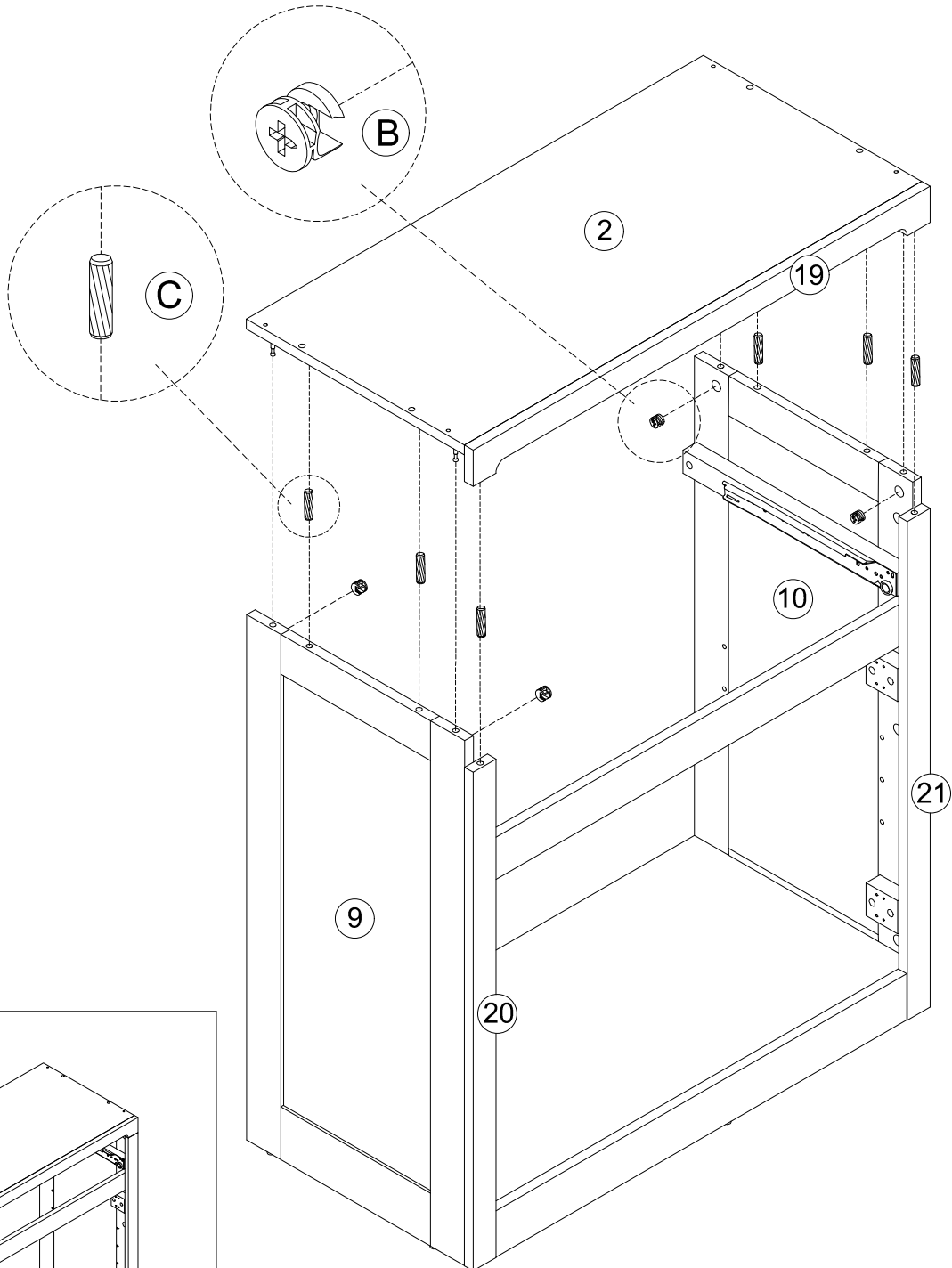
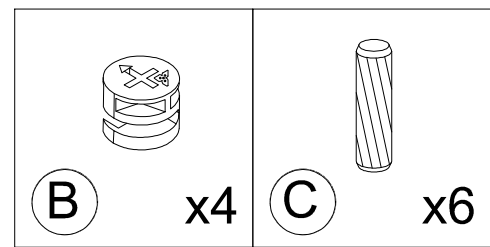

STEP 10

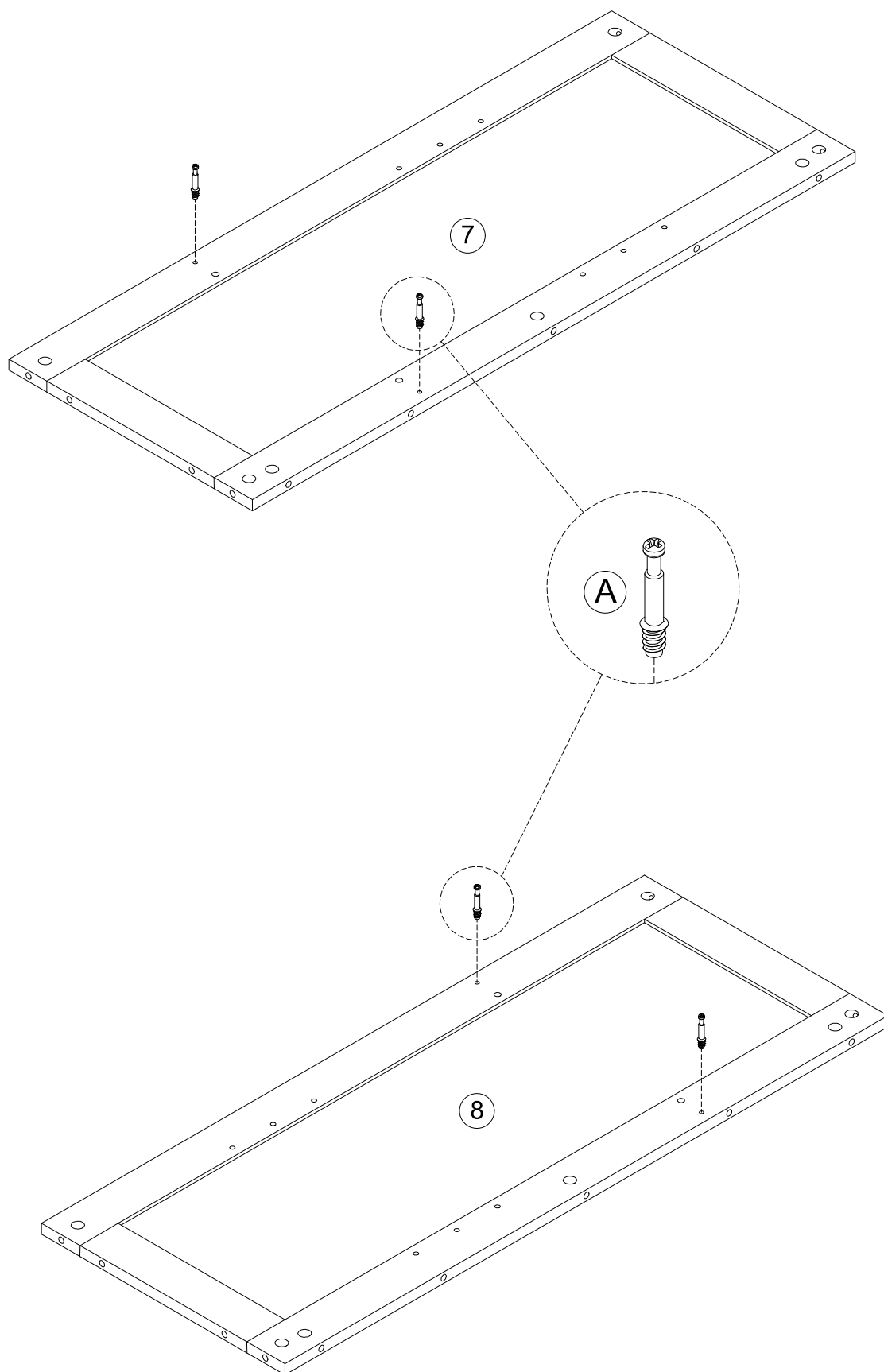
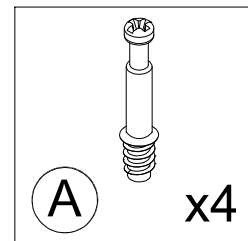

STEP 11

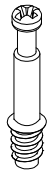

STEP 12

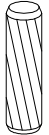
 A x3	 B x3	 C x2
--	---	---

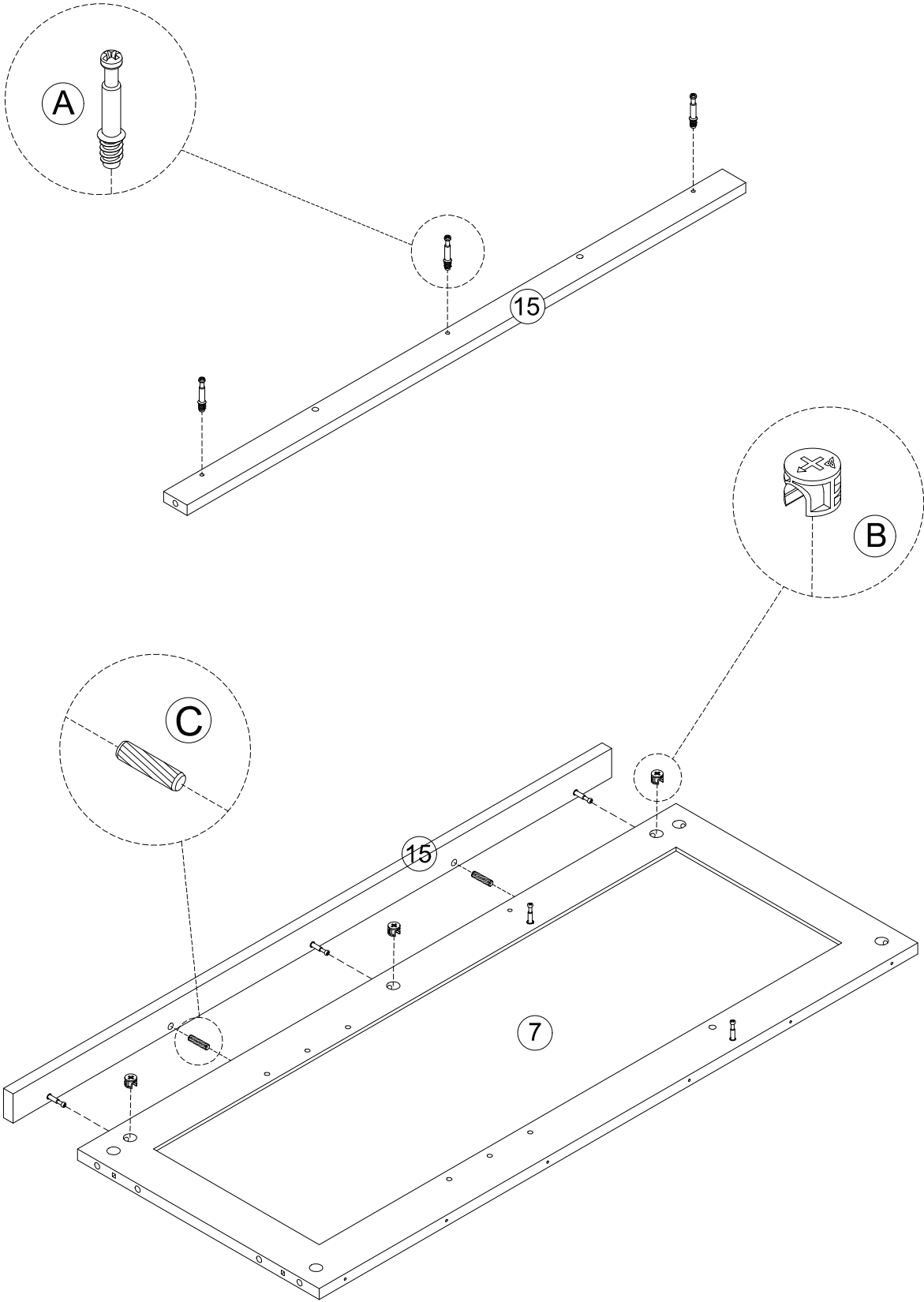

STEP 13

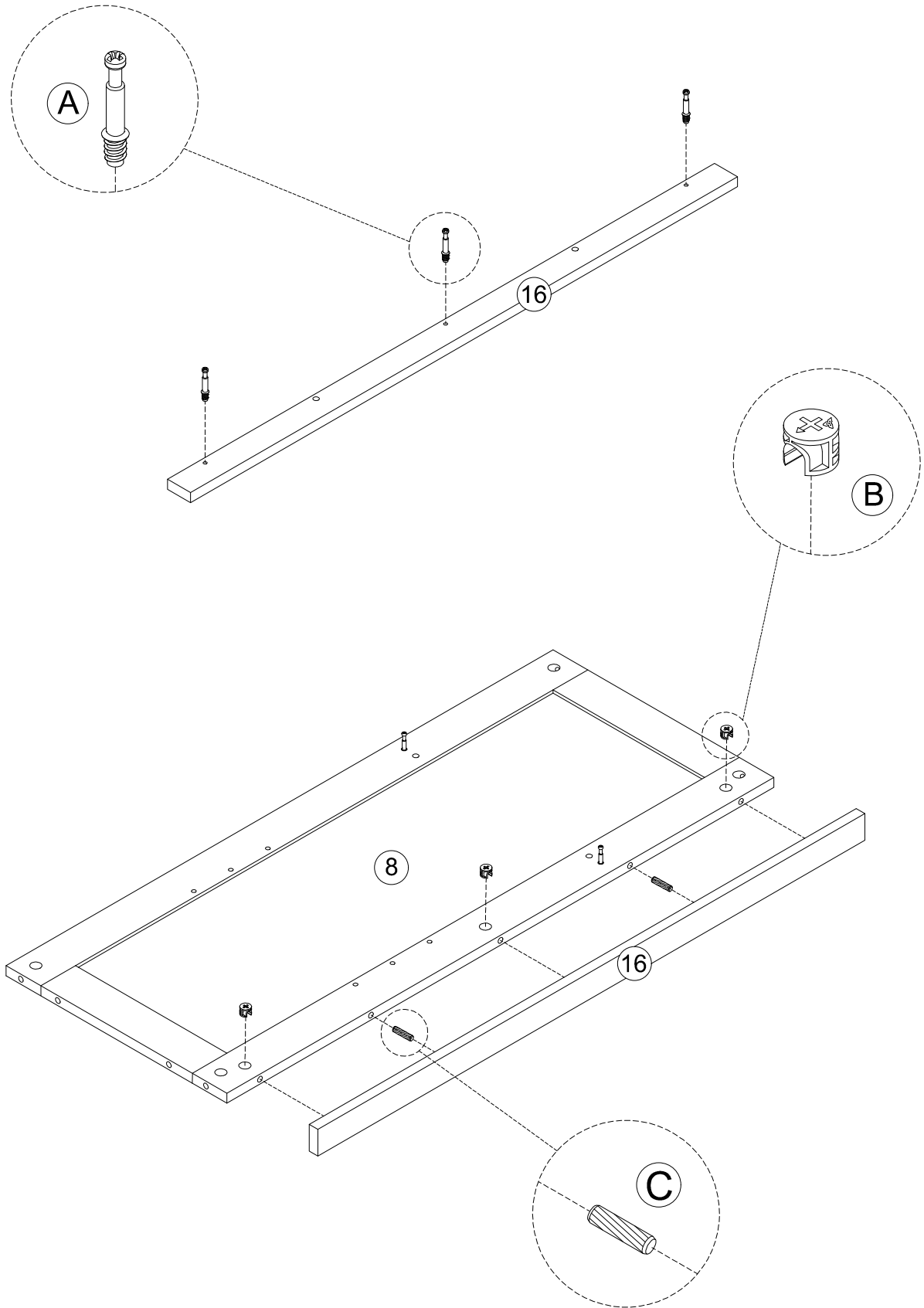
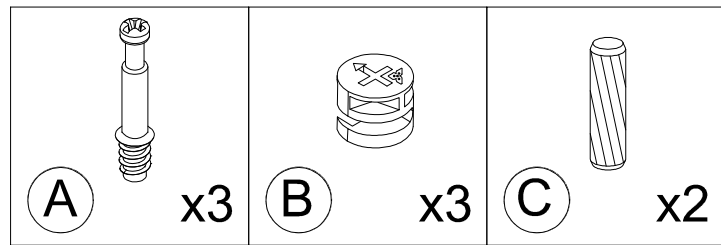

STEP 14

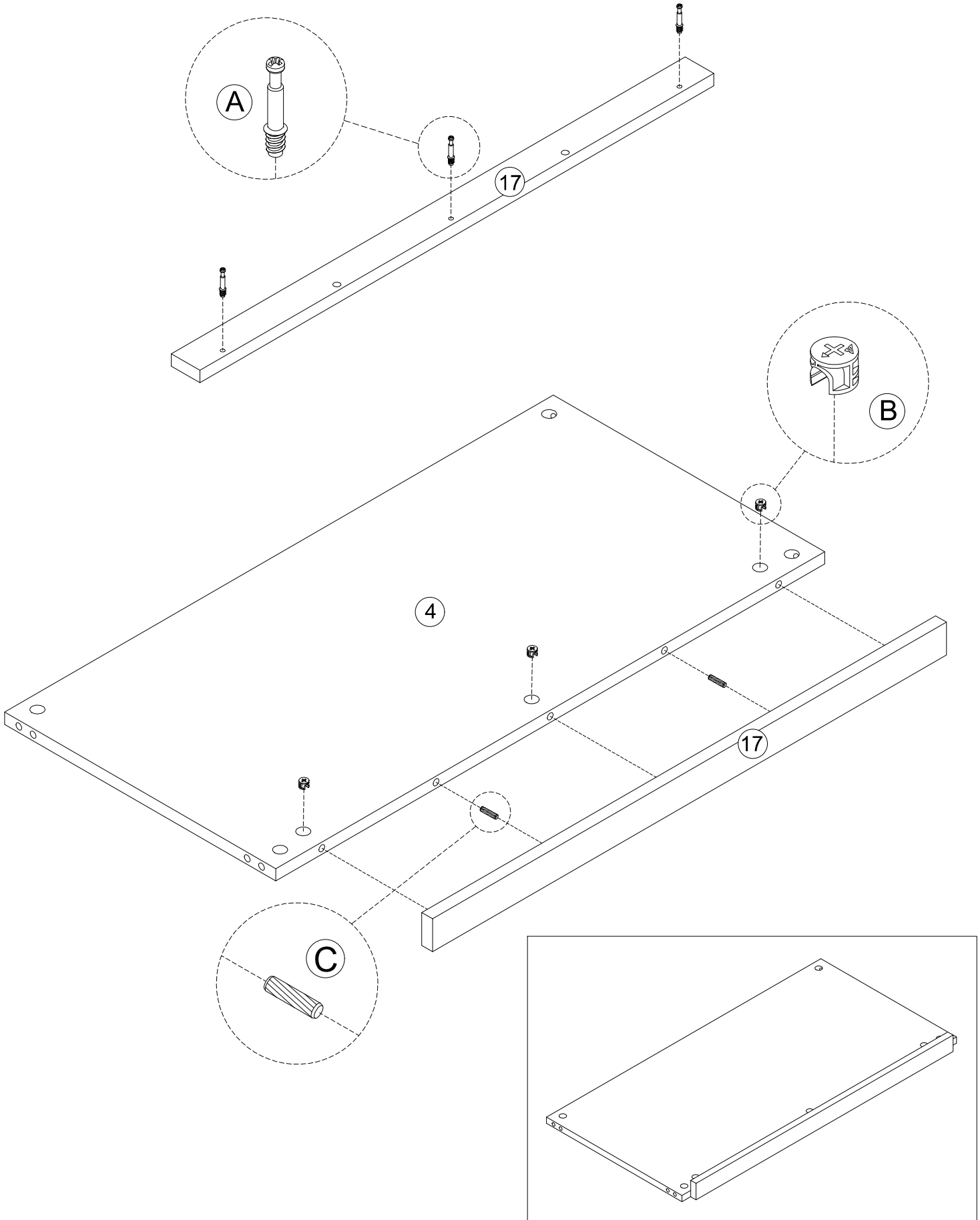
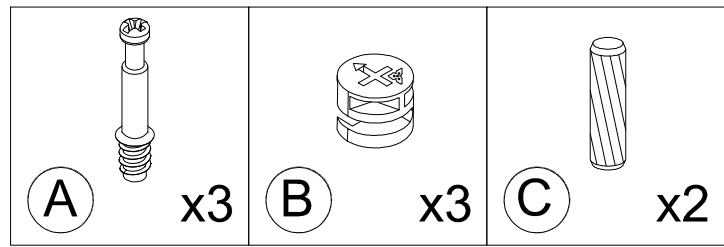

STEP 15

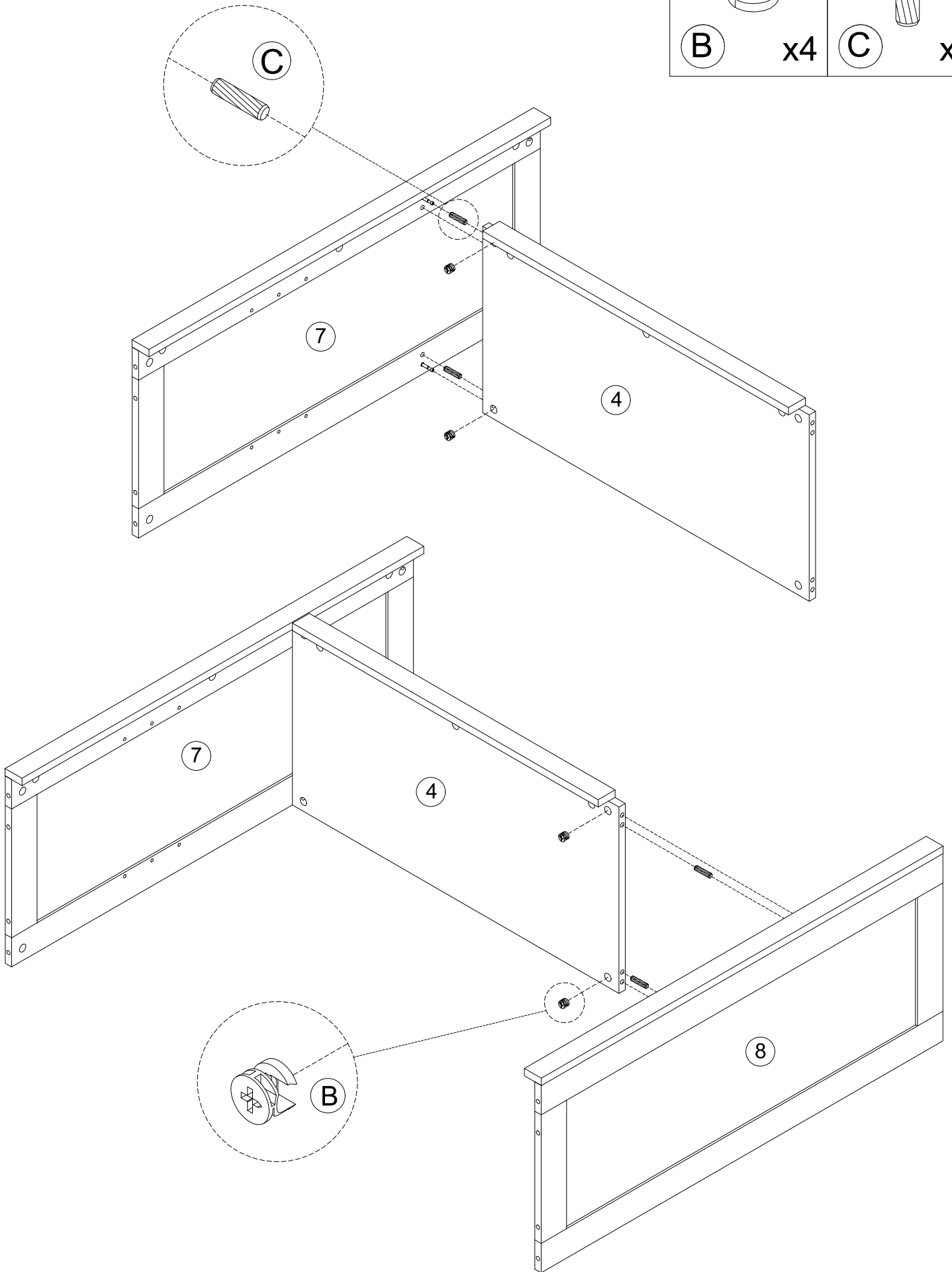
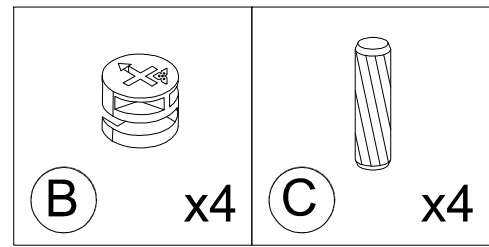

STEP 16

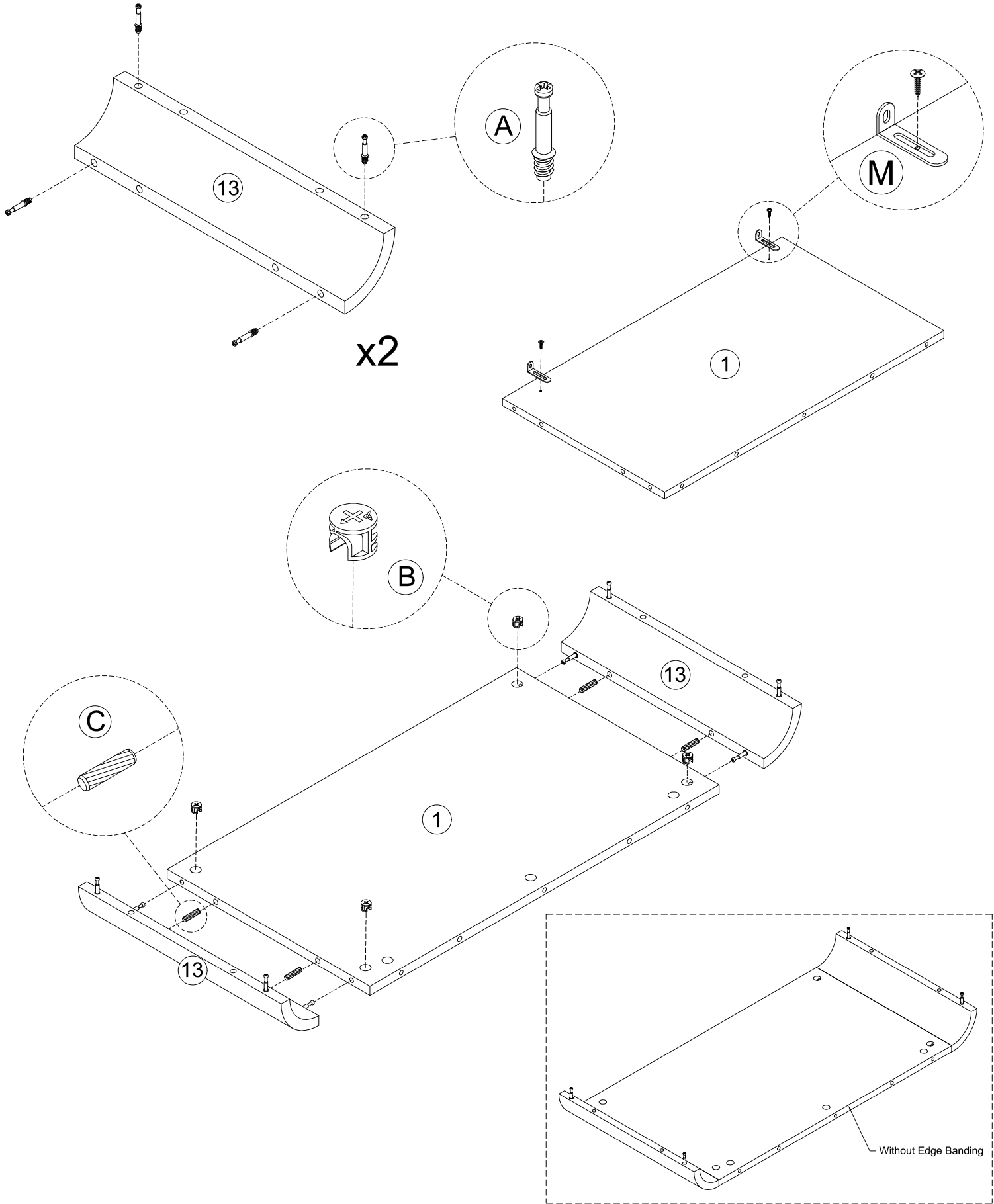
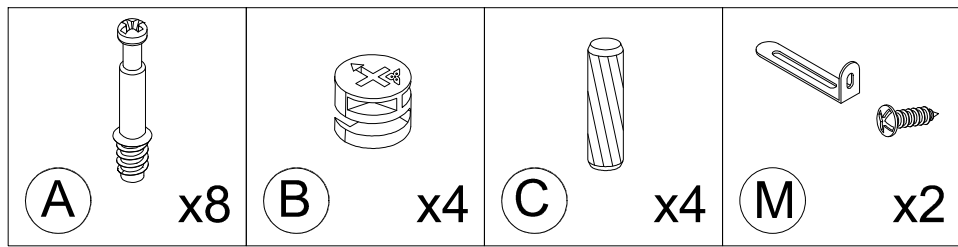

STEP 17

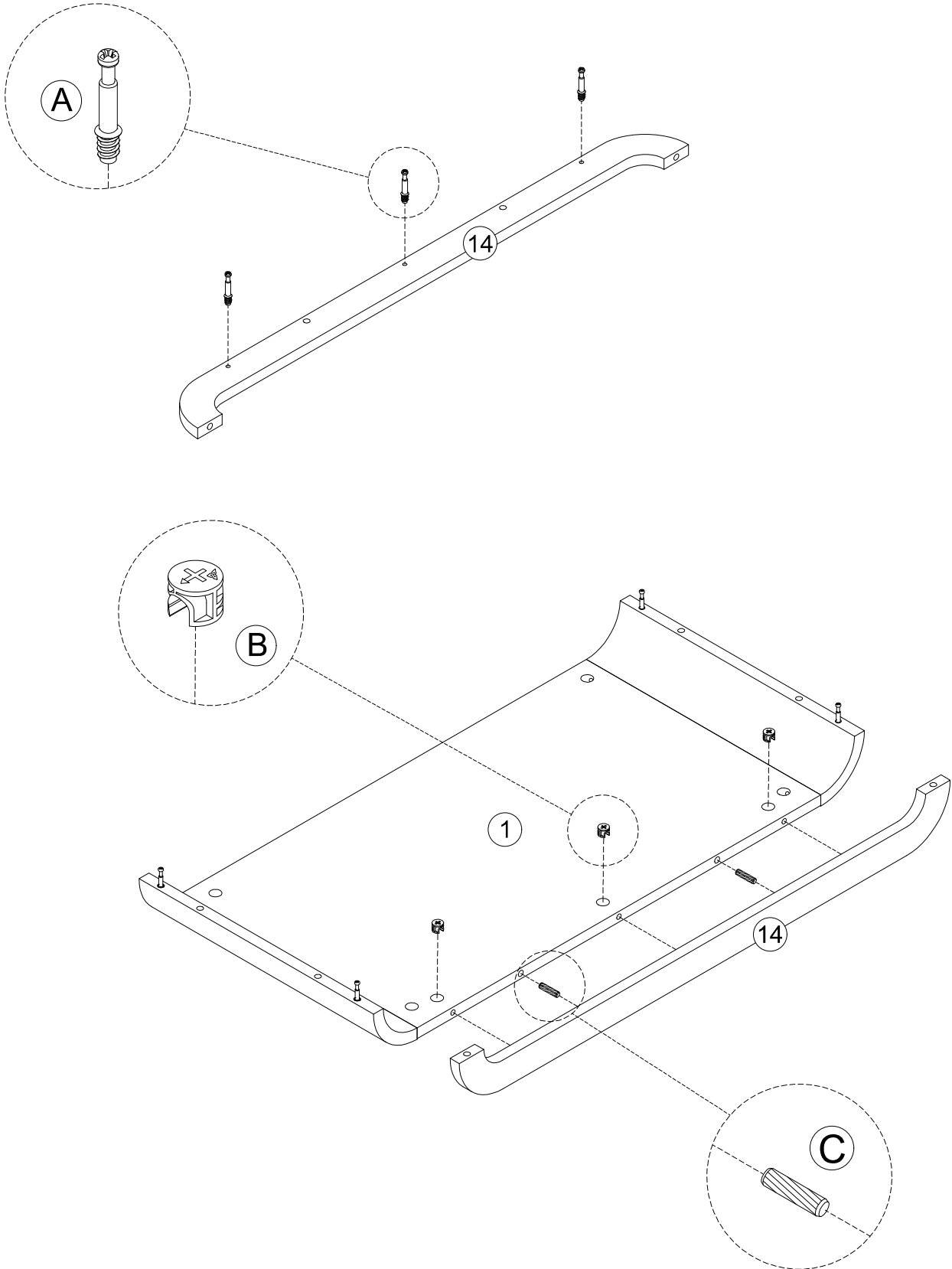
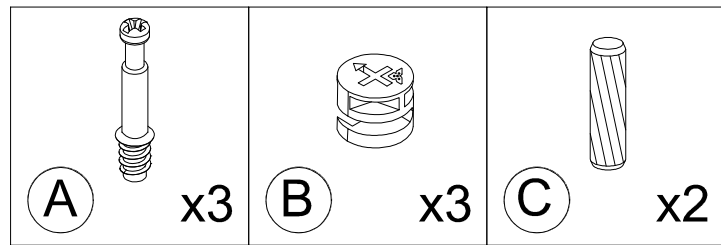

STEP 18

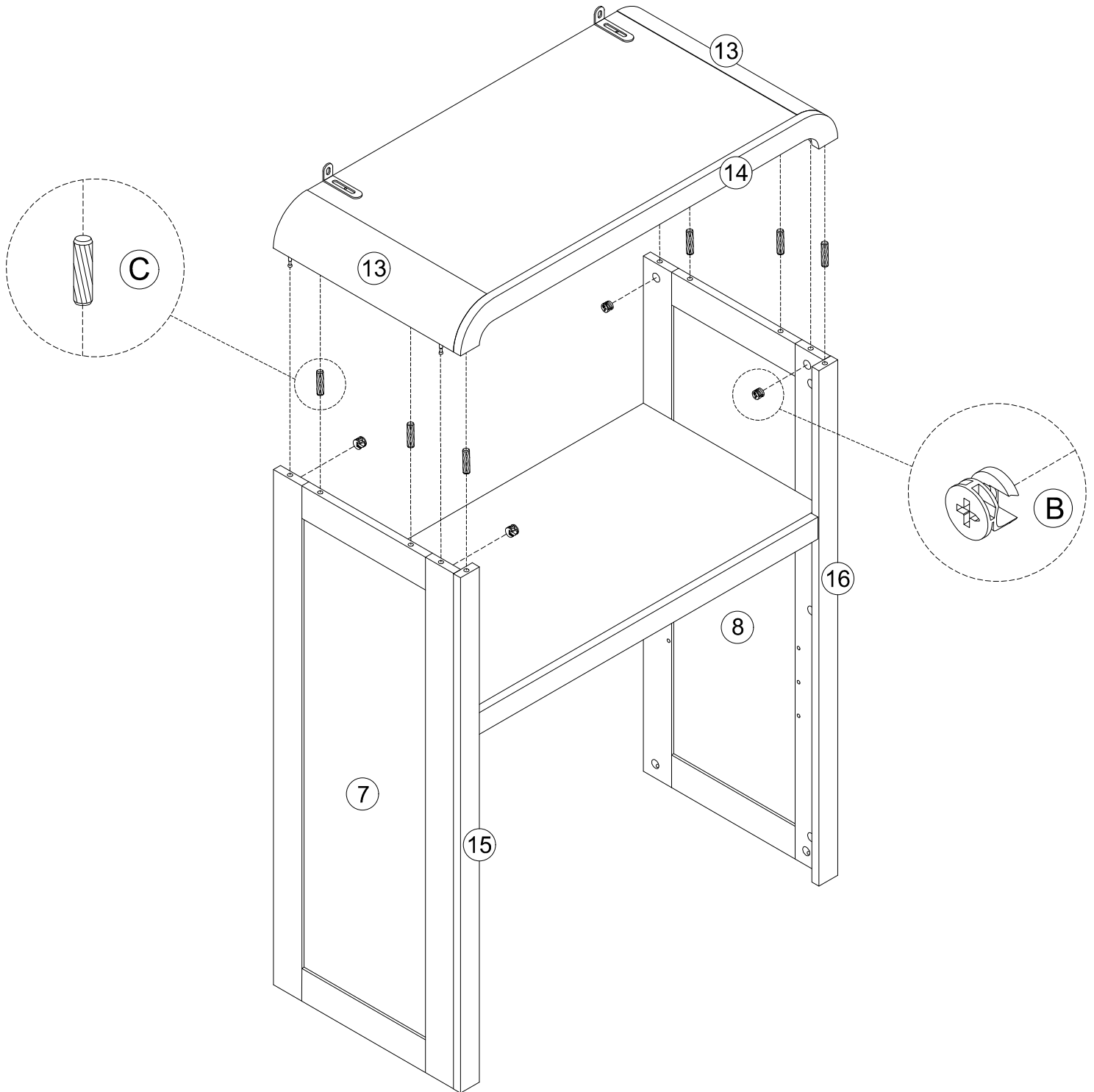
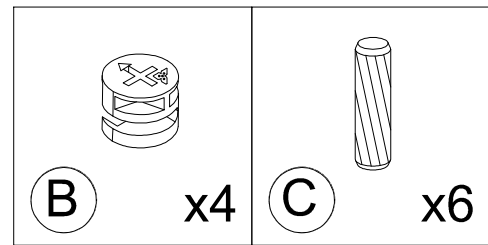

STEP 19

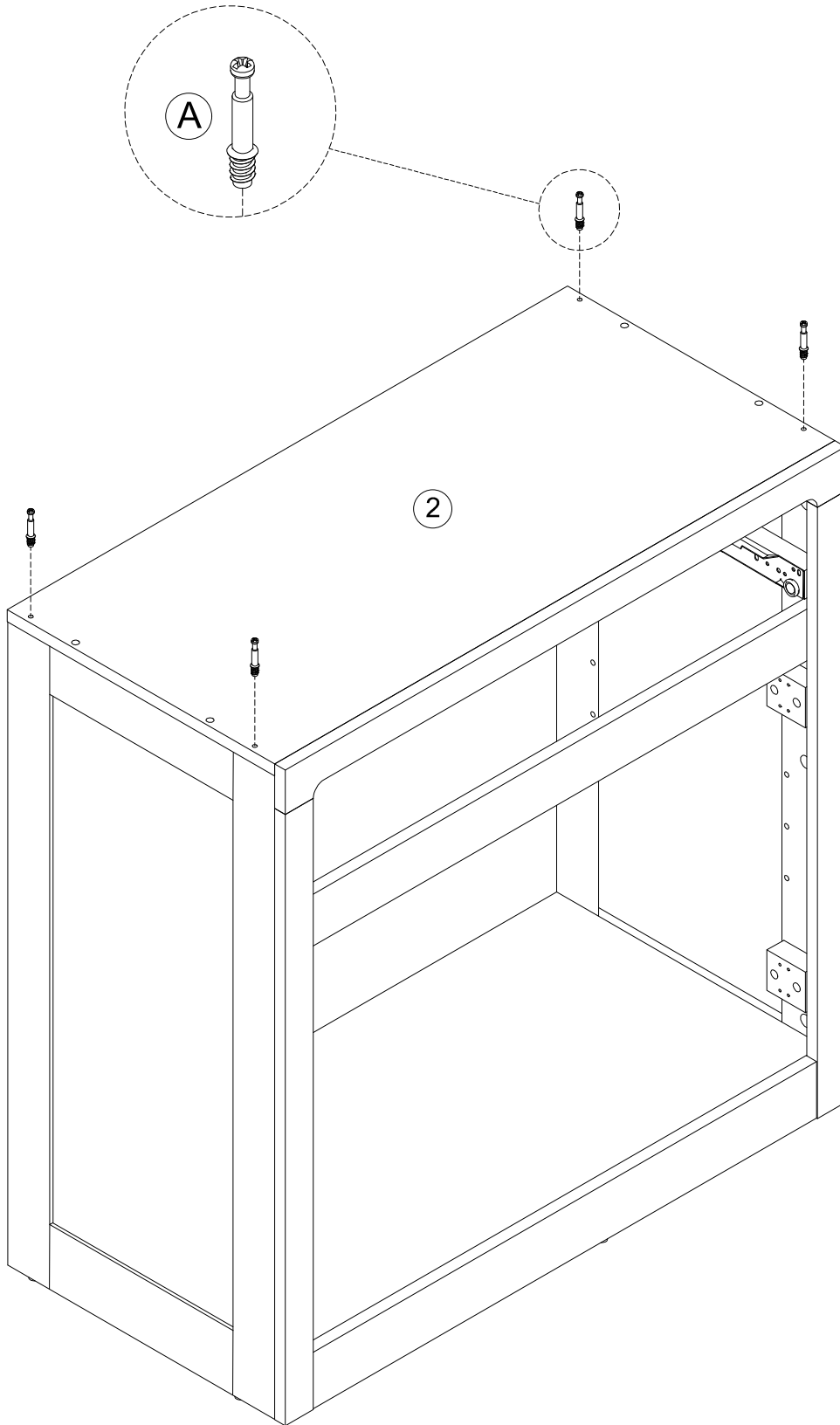
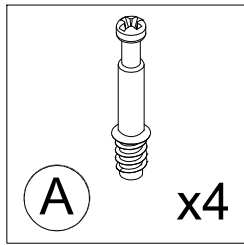

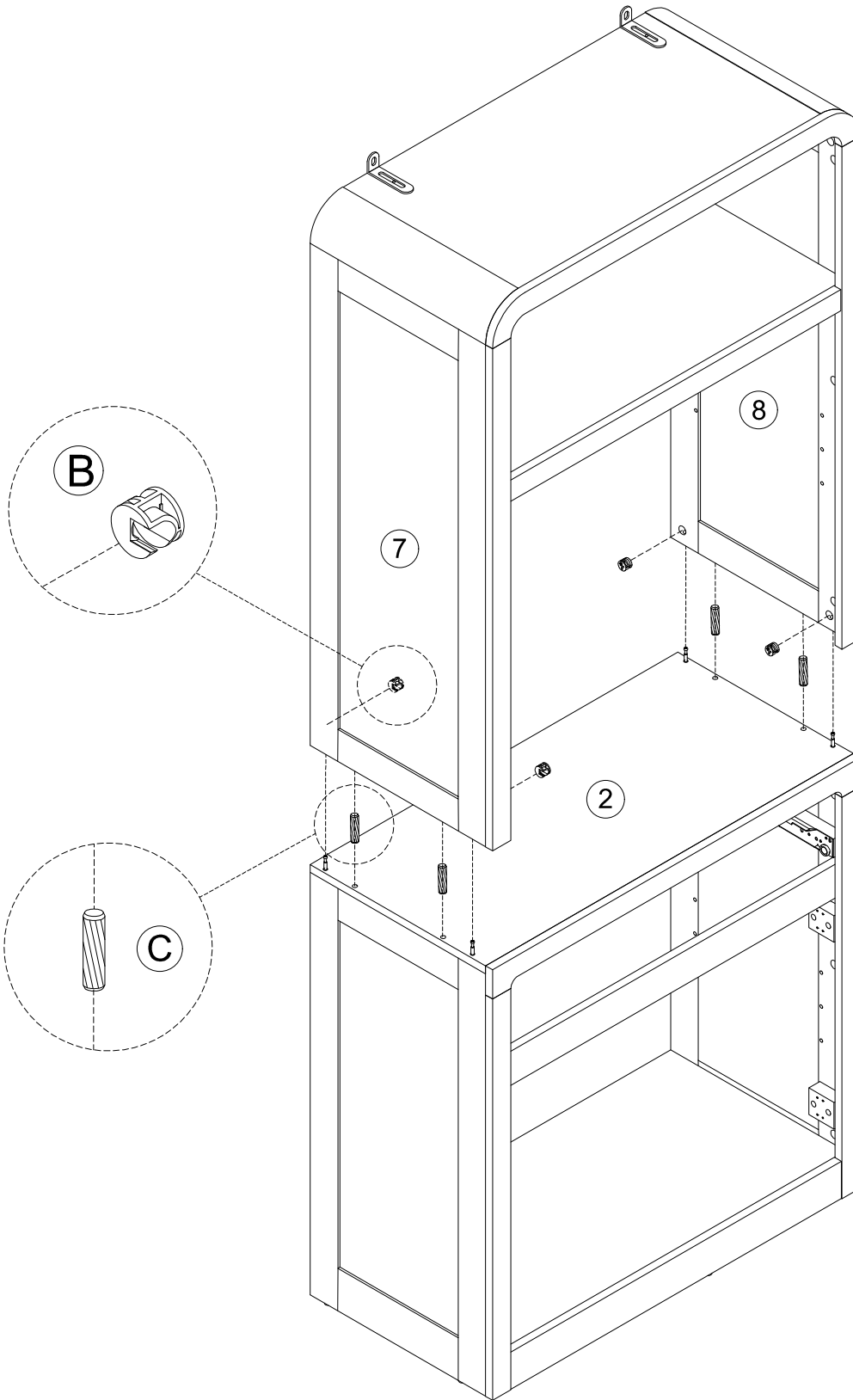
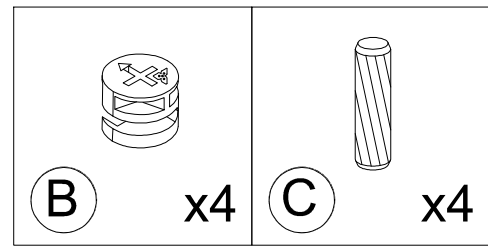

STEP 20

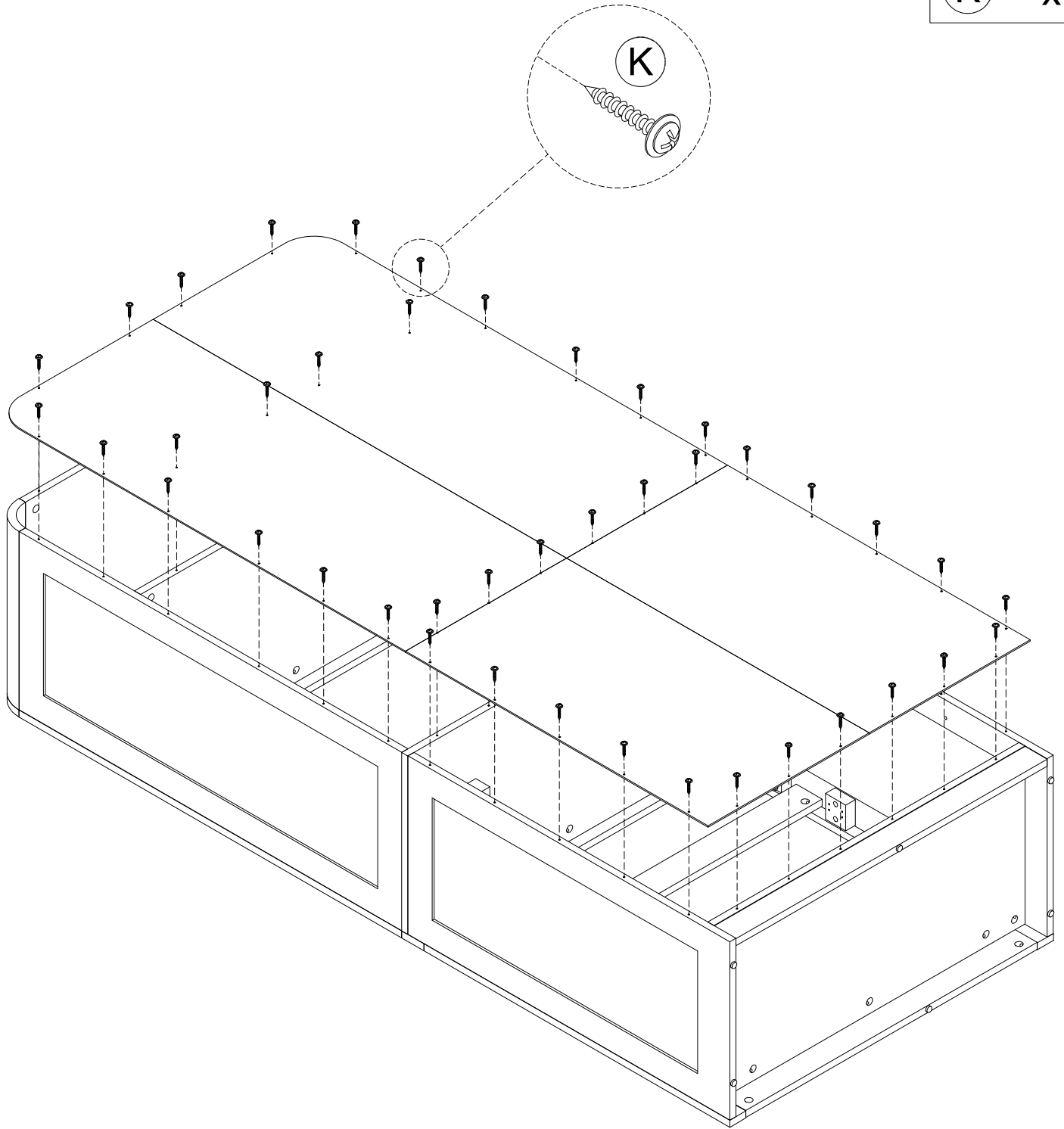
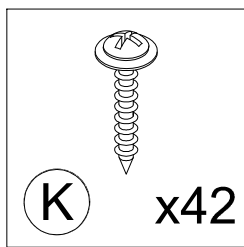

STEP 21

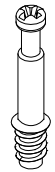

STEP 22

 A x3	 B x3	 C x2
--	---	---

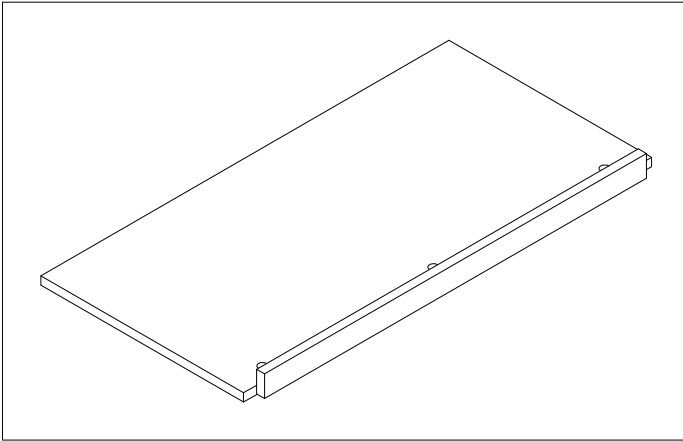
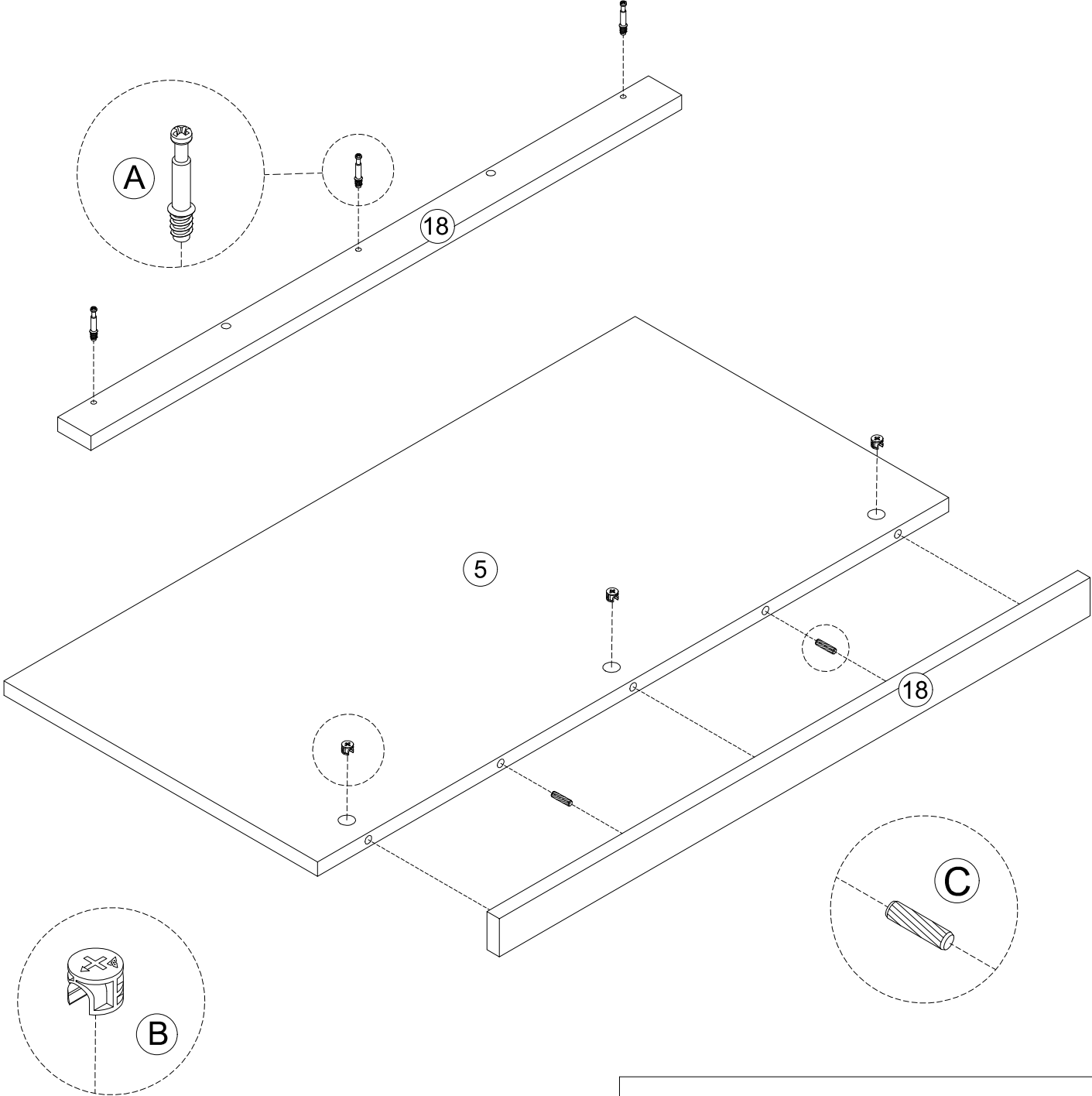

STEP 23

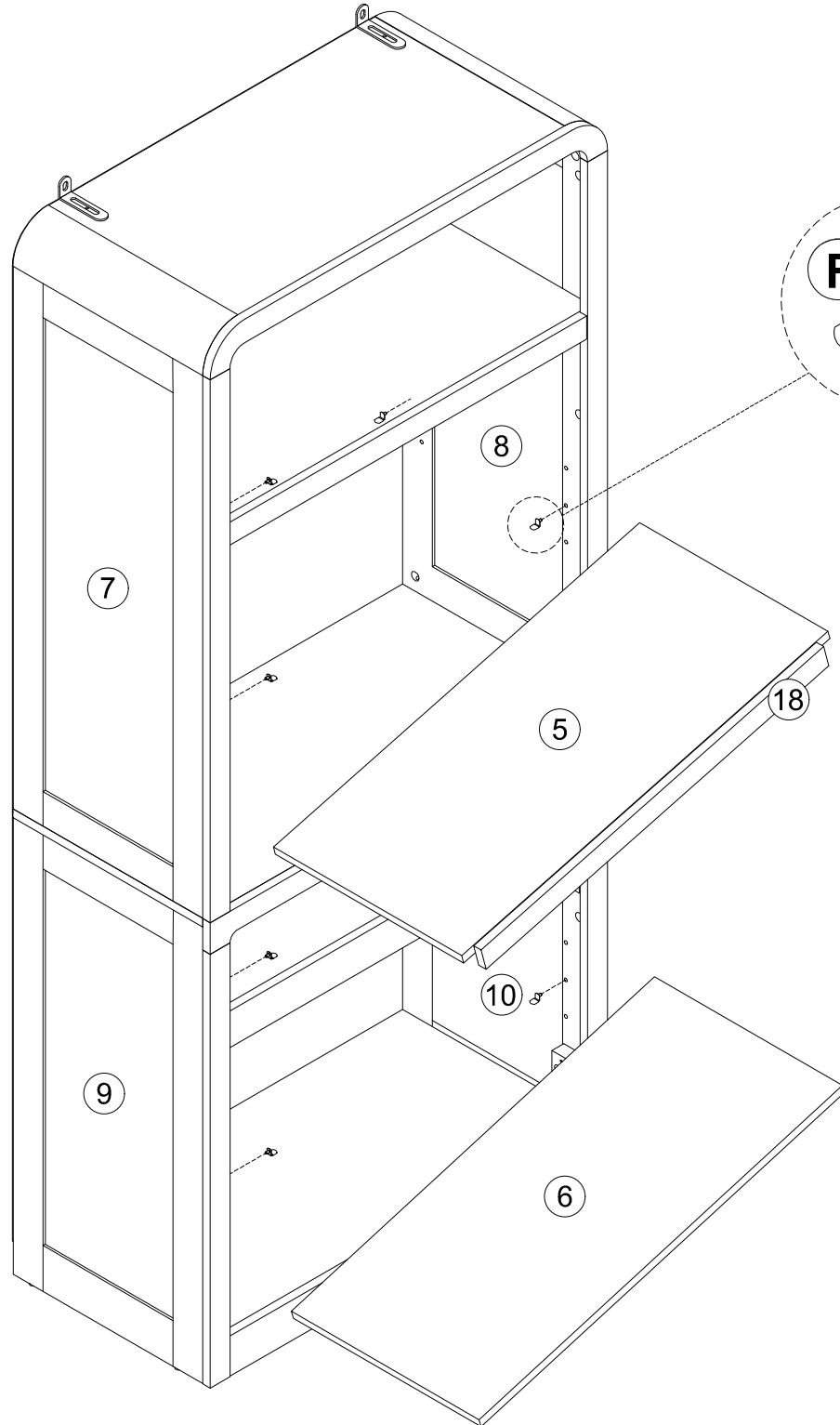
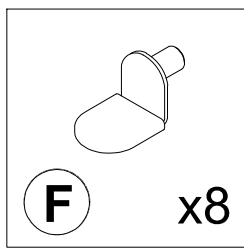

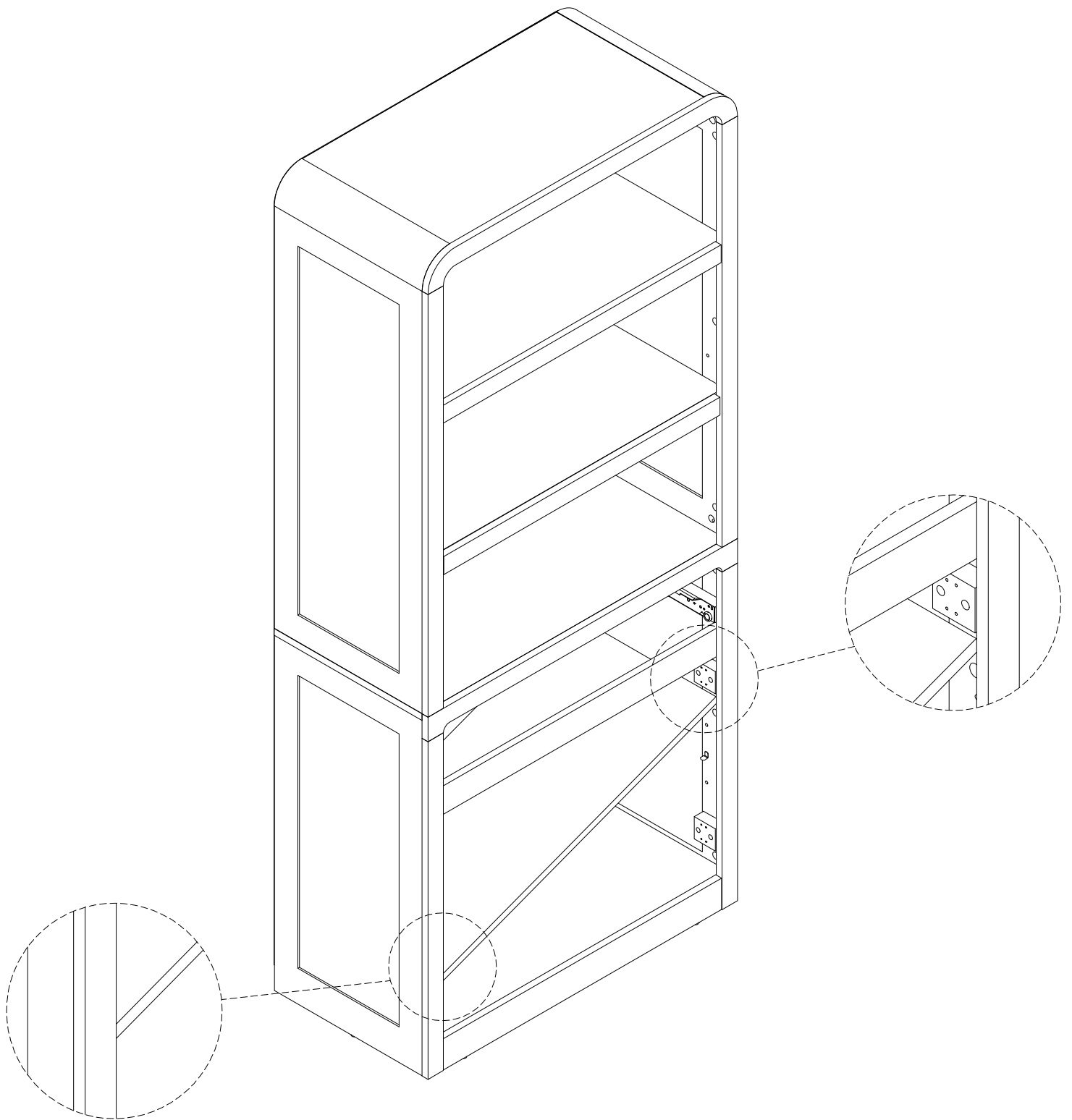

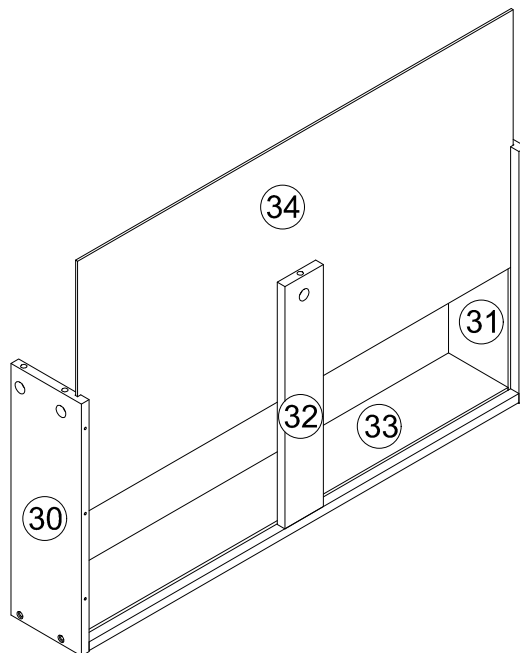
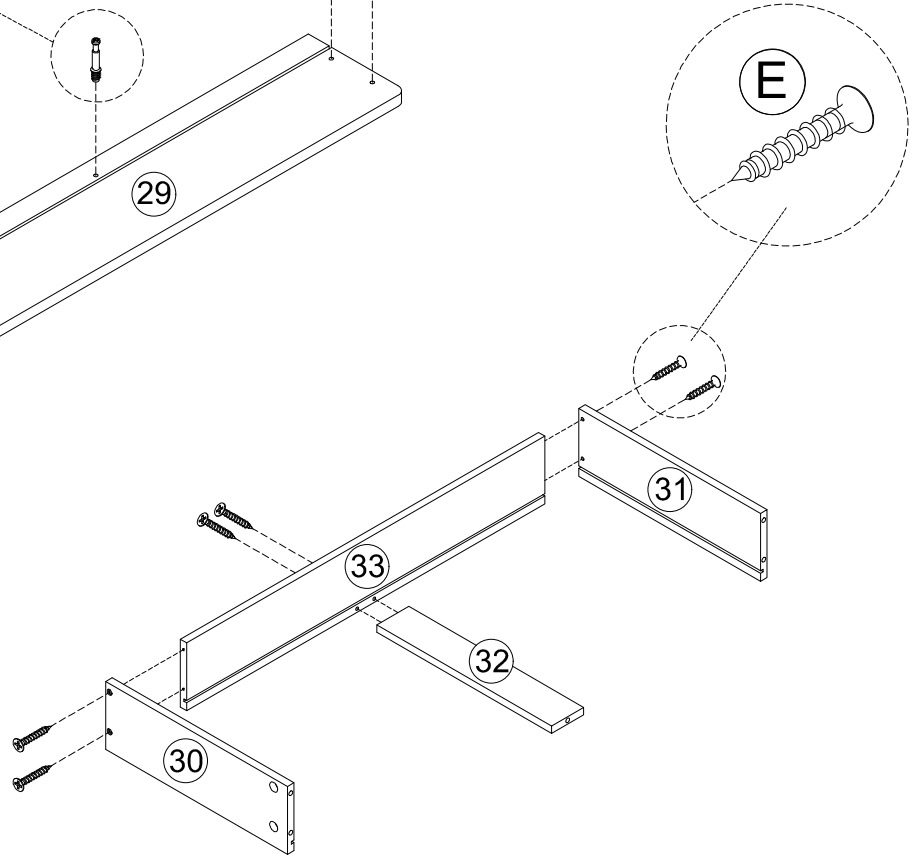
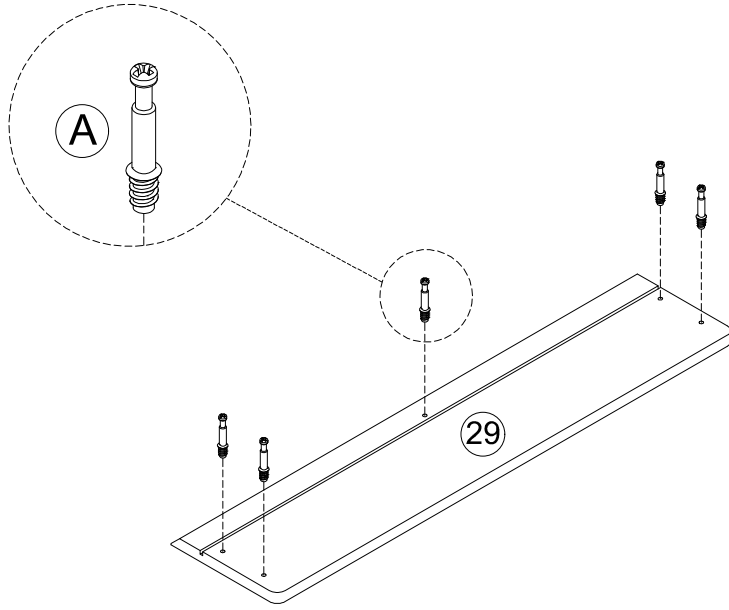
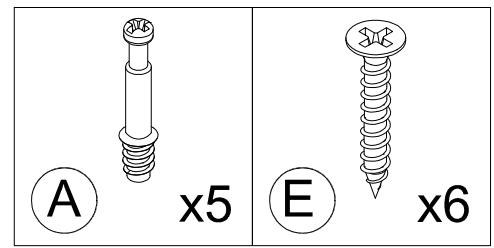

Note: To place the removable shelf, rest one end against the hinge block, slowly lift the other end until it clears the shelf pegs, then lower it flat onto the pegs.

STEP 24

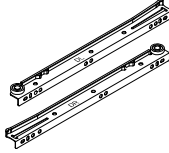

STEP 25

		
B x5	L x1	H x6

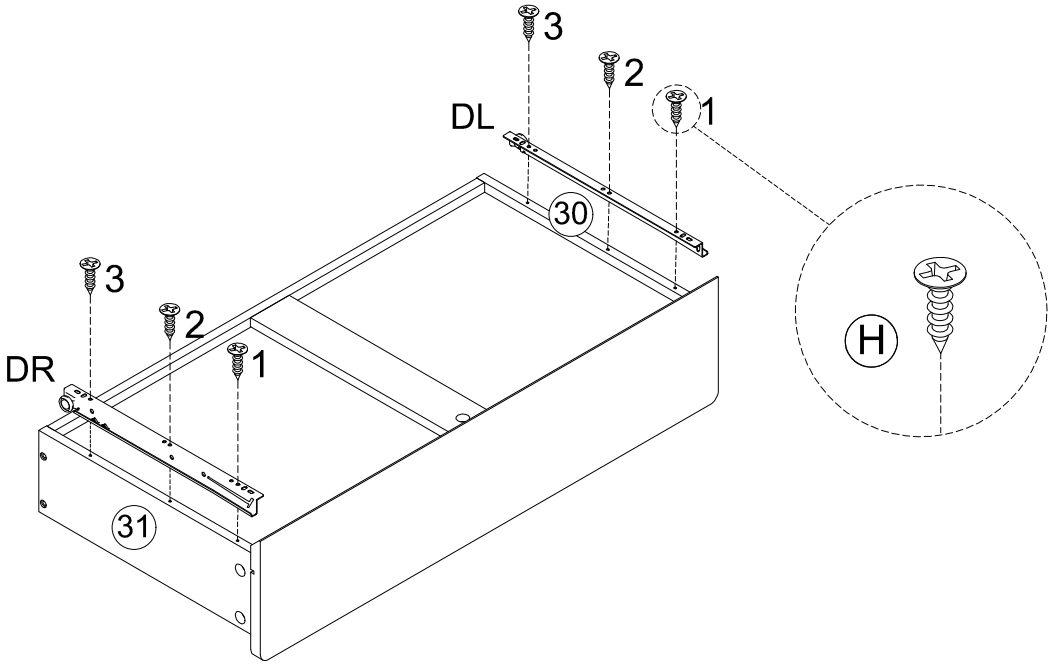
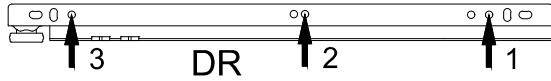
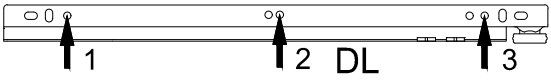
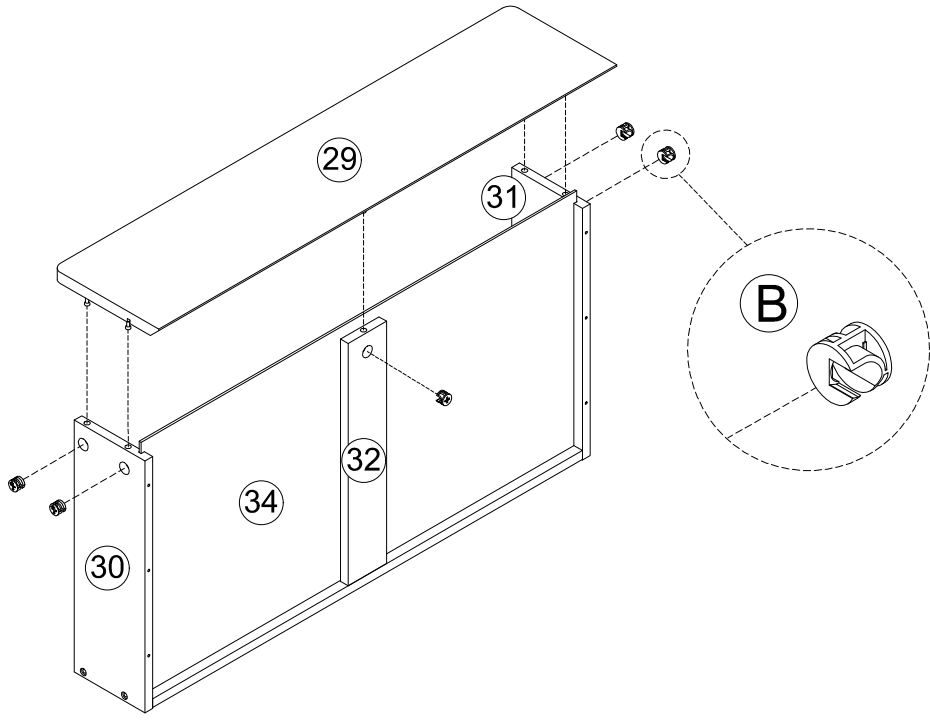

STEP 26

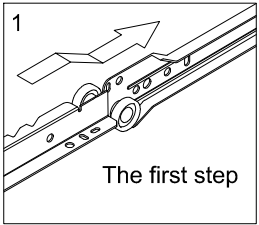
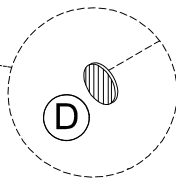
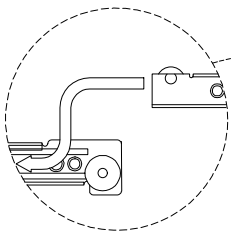
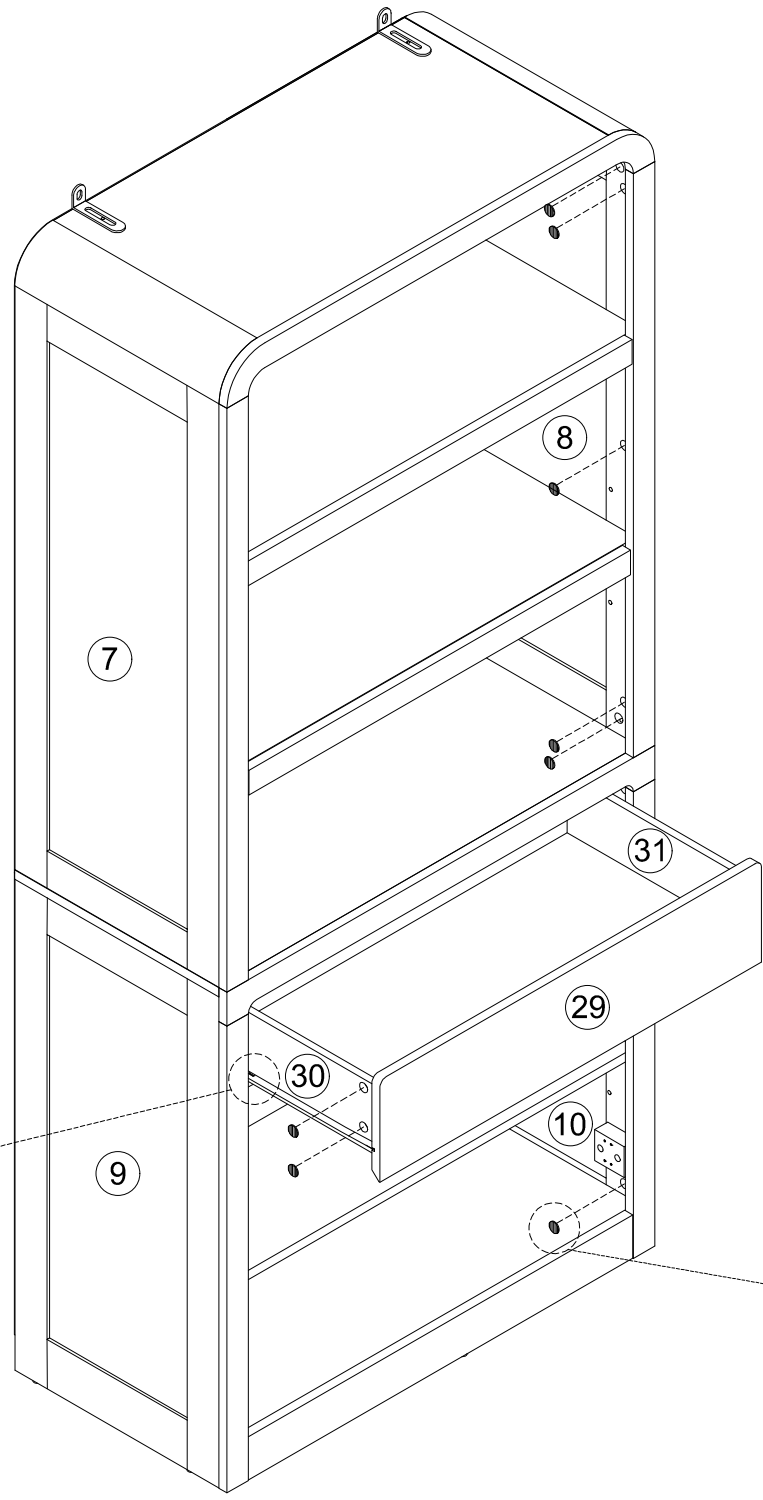
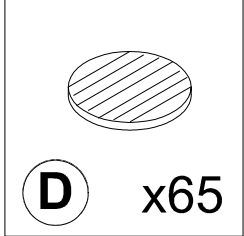

1. When you put the drawer, please note that the drawer wheels on top of the wheels of the slide, then check whether the drawer is smooth when pulled out. Otherwise, the drawer will not be aligned with other drawers.

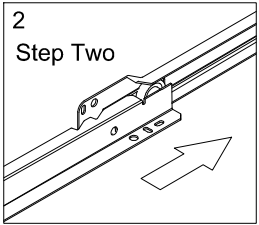
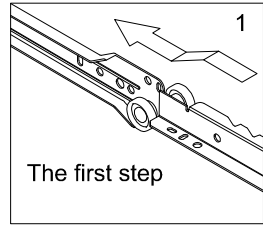

2. Note: When installing, ensure that the sub-rail is fully inserted into the main rail

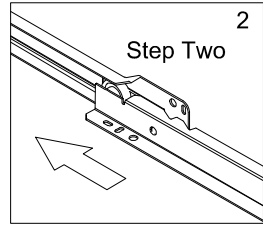

STEP 27

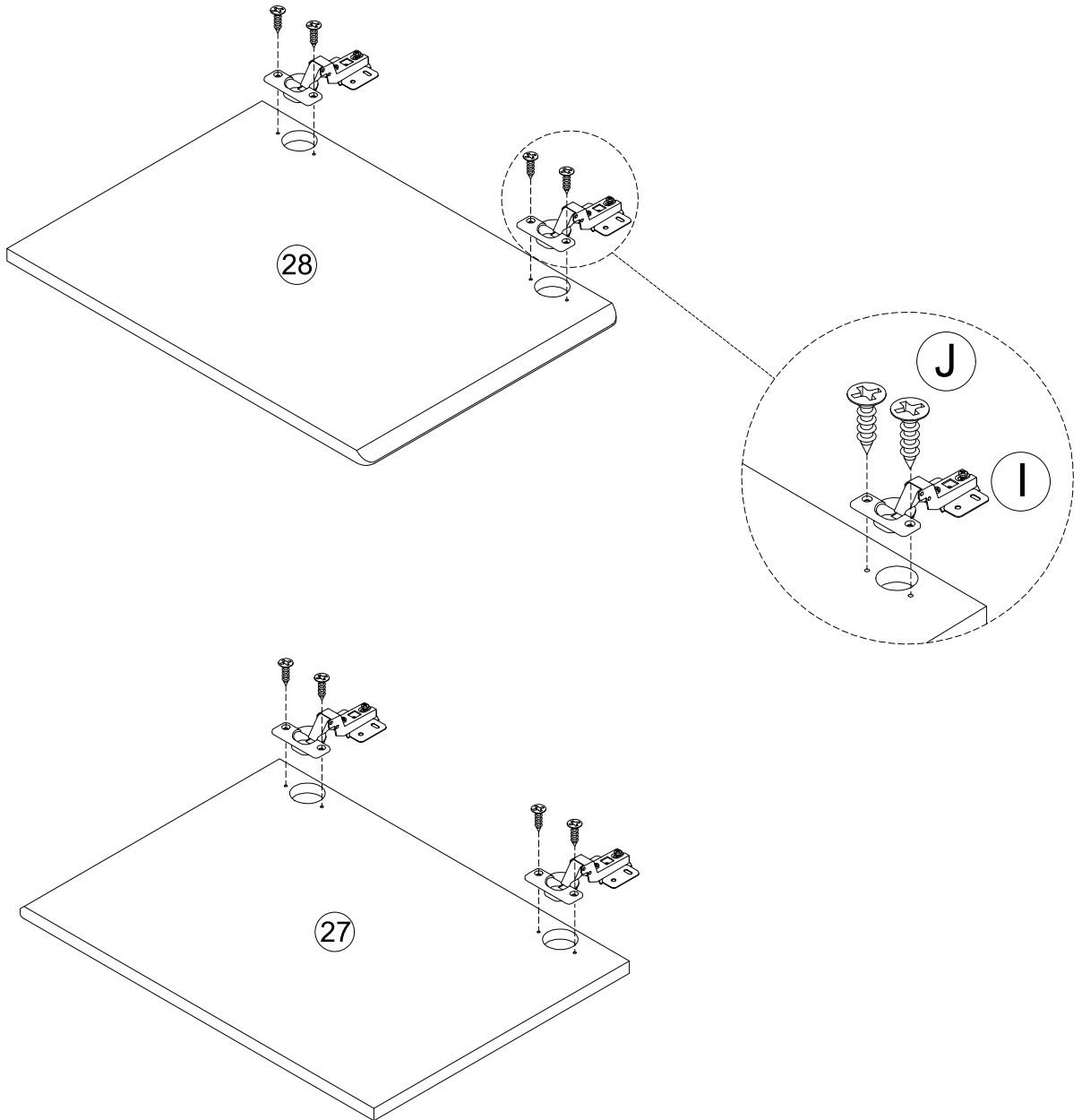
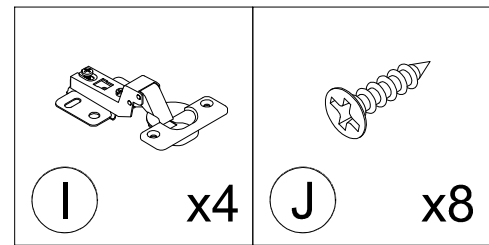

STEP 28

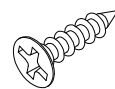

J

x16

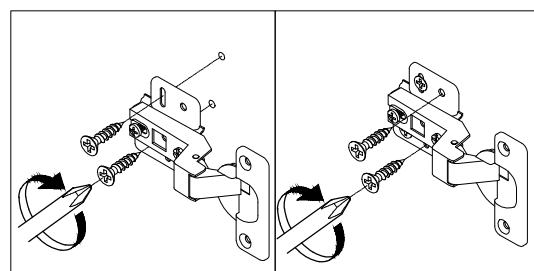
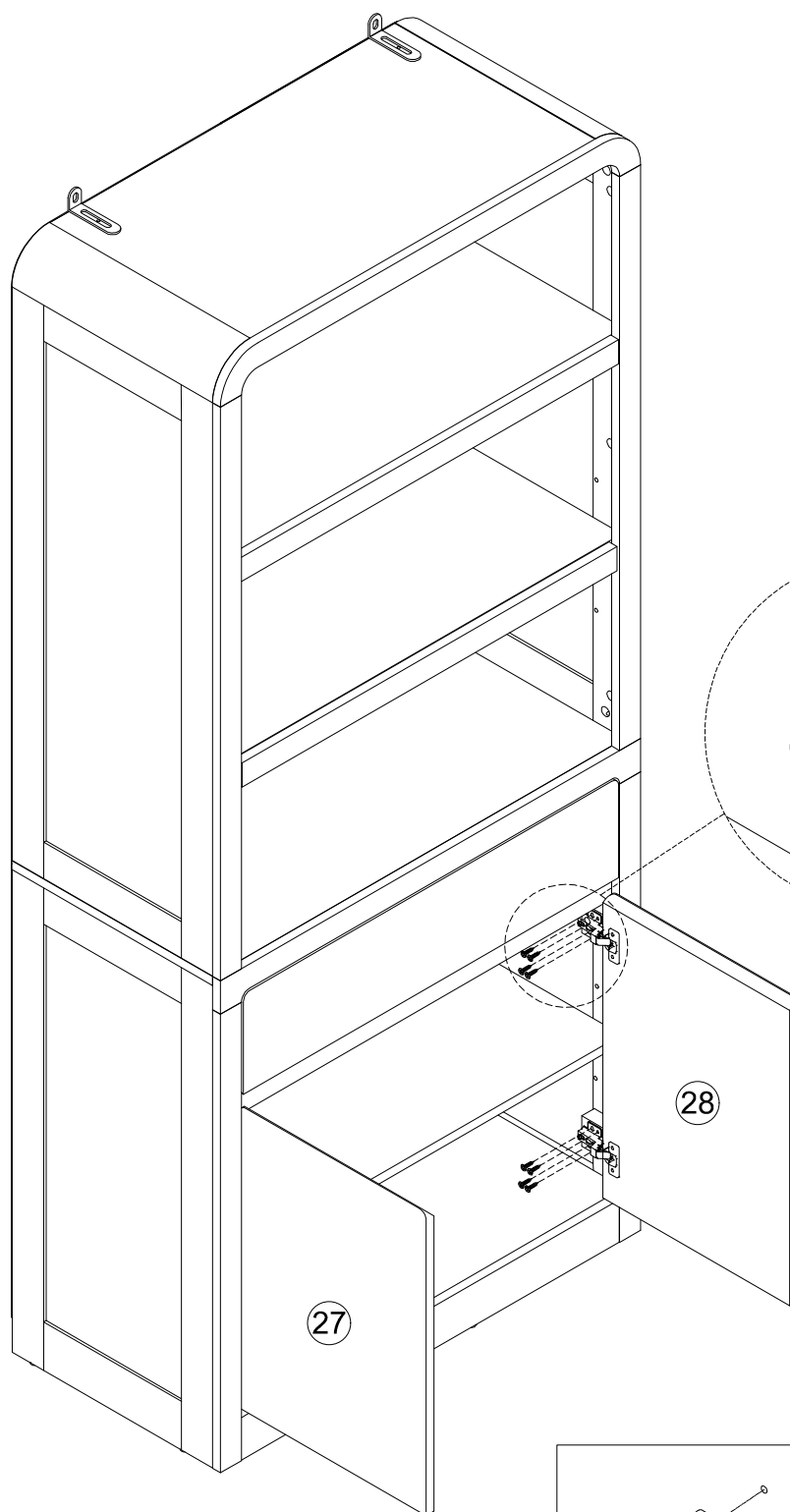

Adjust the position of the cabinet doors.

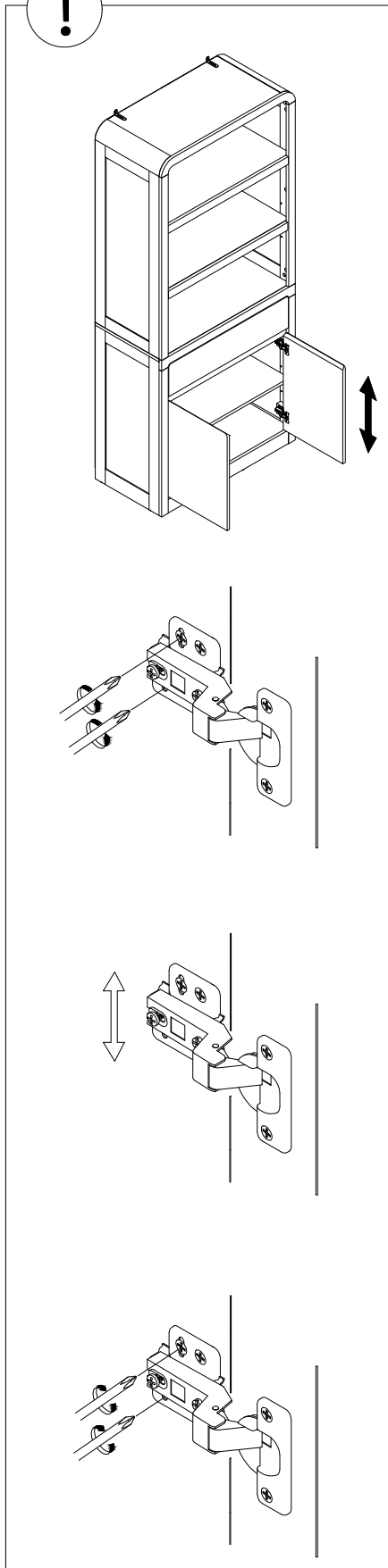

Up and down adjustment by loosening the screws on the mounting plate.

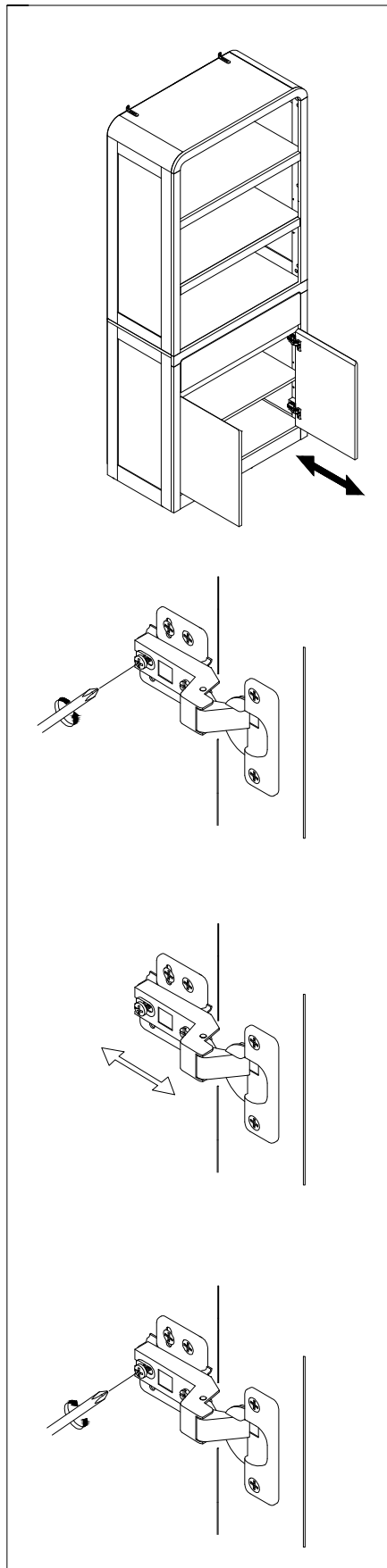

In and out adjustment by loosening the screws on the hinge arm.

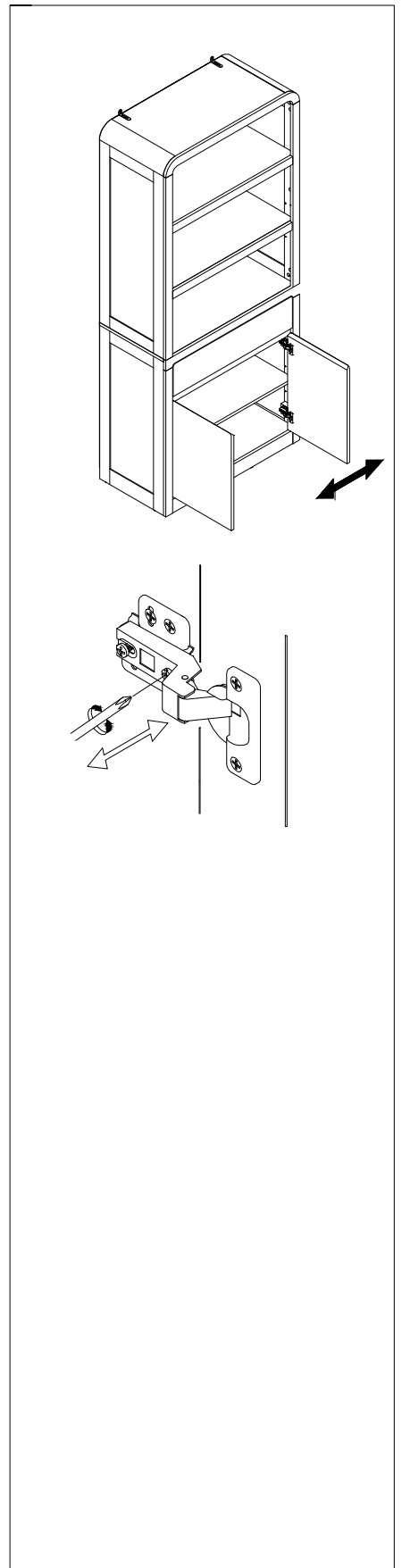

Side to side adjustment using the front adjustment screw on the hinge.

STEP 29

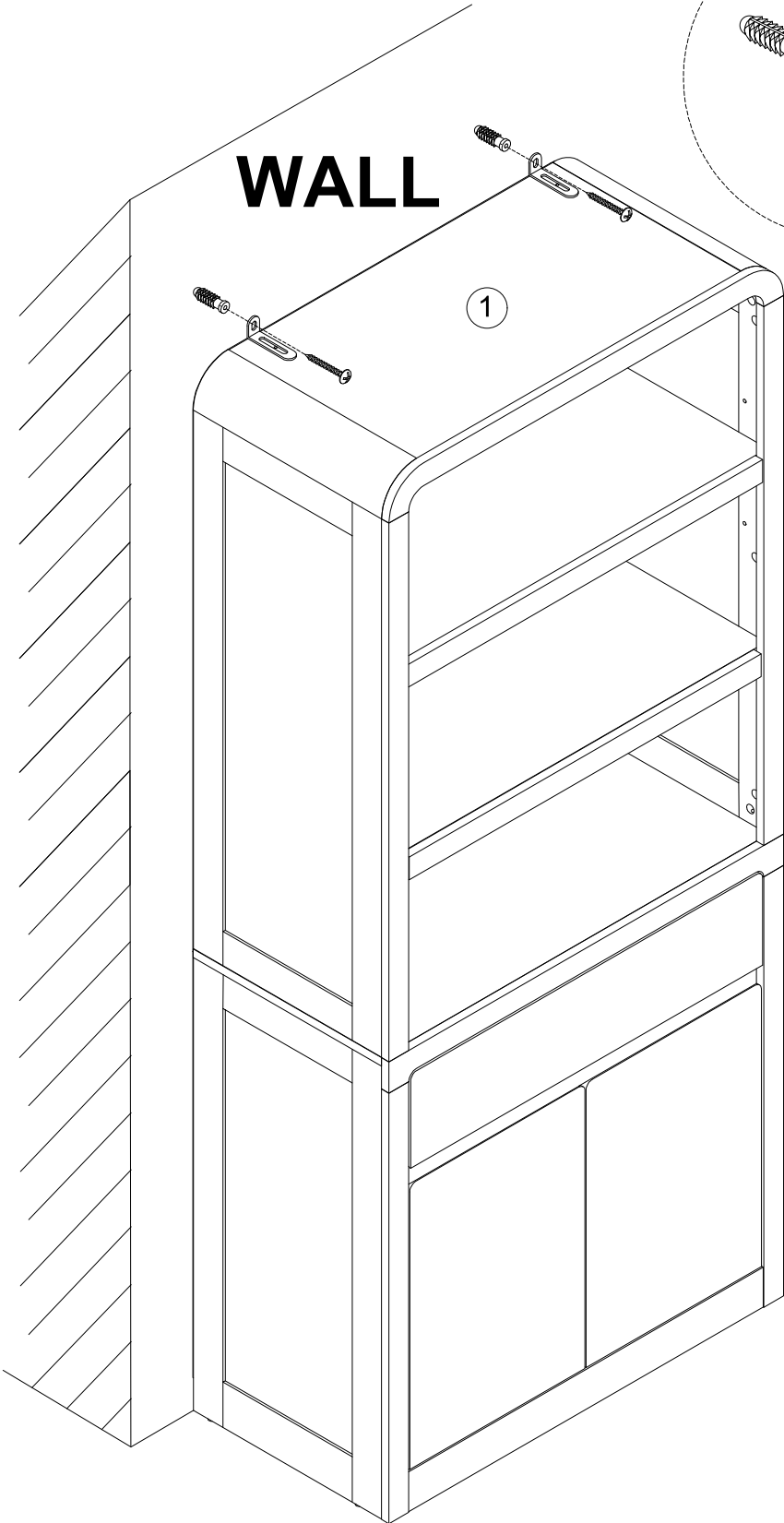
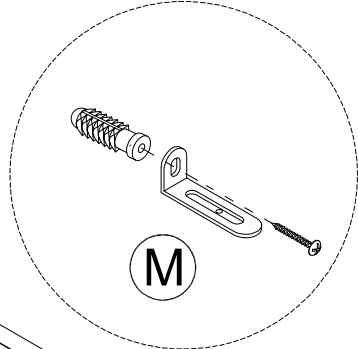
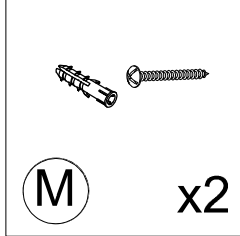
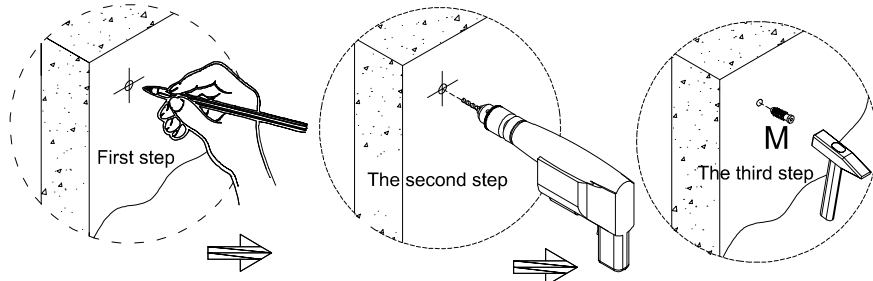

▲ WARNING	
	<p>Children have died from furniture tipover. To reduce the risk of furniture tipover:</p> <ul style="list-style-type: none"> • ALWAYS install anti-tip device provided. • NEVER put a TV on this product. • NEVER allow children to stand, climb or hang on any drawers, doors, or shelves. • NEVER open more than one drawer at a time. • Place heaviest items in the lowest drawers.
	<p><i>this is a permanent label. Do not remove!</i></p>