

ASSEMBLY INSTRUCTION

ITEM NO.N715P406515

Please read these instructions fully before starting assembly:

1. Place all wooden parts on a clean and smooth surface such as a rug or carpet to avoid scratching the parts.
2. Kindly follow the assembly instructions step by step.
3. Do not tighten all screws and bolts until the table is fully assembled.
4. Unscrew the protective plastique supports from the metal insert of the table legs before assembly.
5. Parts of the assembly will be easier with 2 people.

Care and maintenance:

Only clean using a damp cloth and mild detergent, do not use bleach or abrasive cleaners.

ASSEMBLY INSTRUCTION

ITEM NO.N715P406515

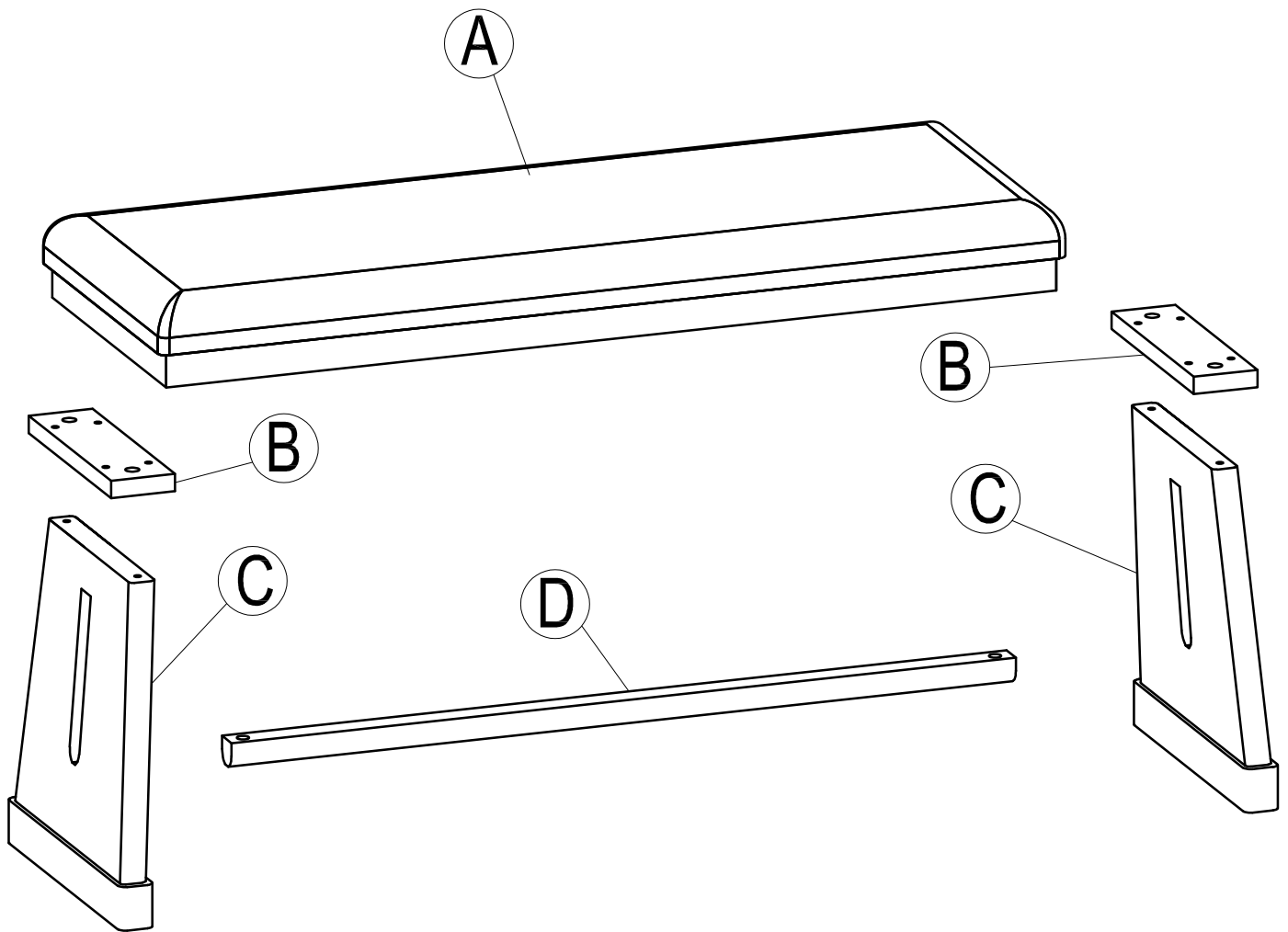

ASSEMBLY INSTRUCTION

ITEM NO.N715P406515

Part List

(A)

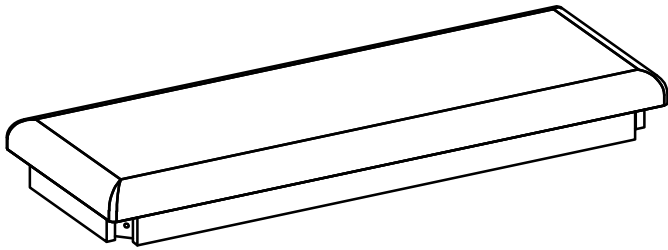

BENCH CUSHION SEAT (1 pc)

(B)



LEG (2 pcs)

(C)

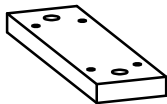

PANEL TOP LEG (2pcs)

(D)

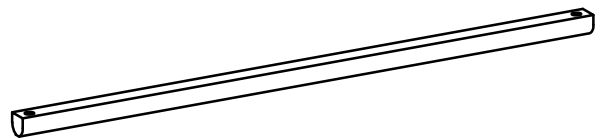

STRETCHER (1 pc)

ASSEMBLY INSTRUCTION

ITEM NO.N715P406515

Hardware List

①

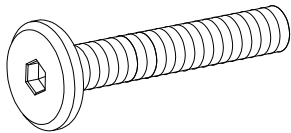

Ø 1/4" x 35mm

BOLT (14pcs)

②

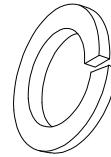

Ø5/16" x 13mm

LOCK WASHER (14 pcs)

③

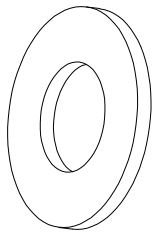

Ø5/16" x 19 x 2mm

FLAT WASHER (12 pcs)

④

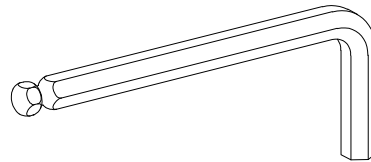

4mm

ALLEN KEY (1pc)

⑤

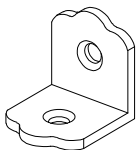

19x18x1.5 mm

PATCH (2 pcs)

⑥

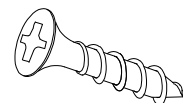

Ø3 x 12 mm

WOOD SCREW (4 pcs)

Tools Requires

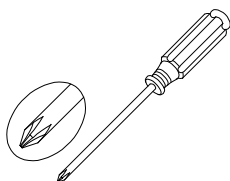

NOT INCLUDED

ASSEMBLY INSTRUCTION

ITEM NO.N715P406515

STEP 1:

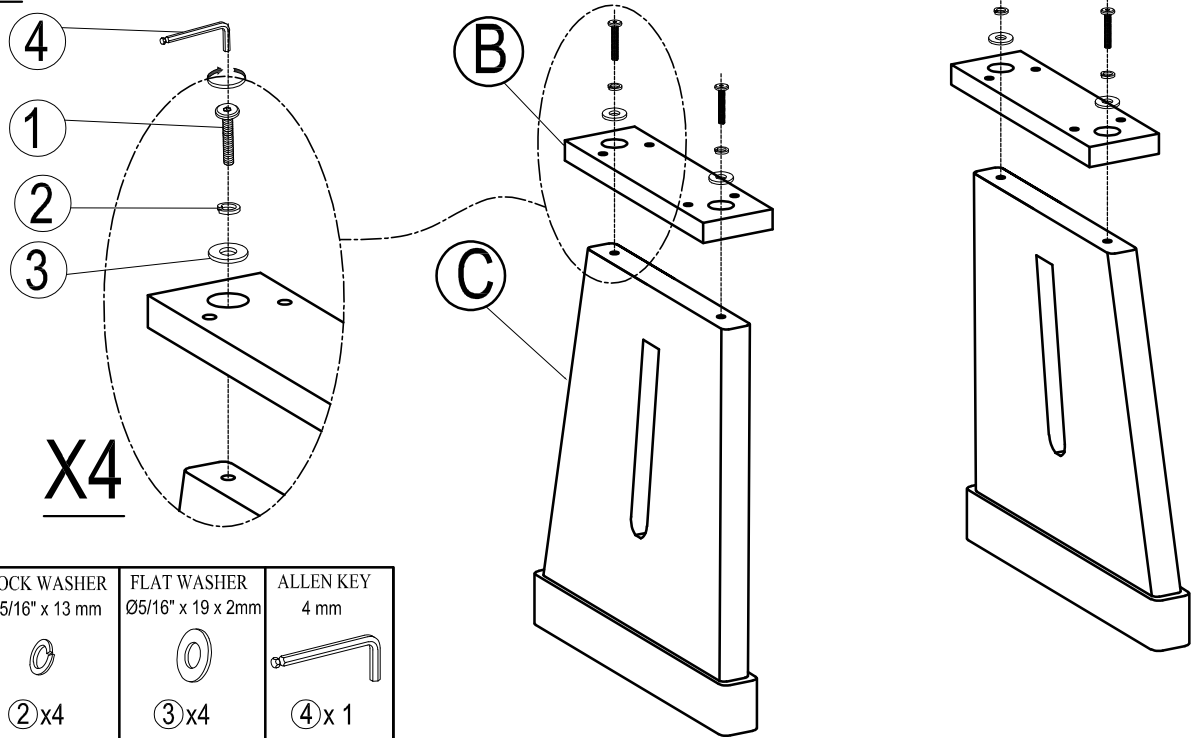

STEP 2:

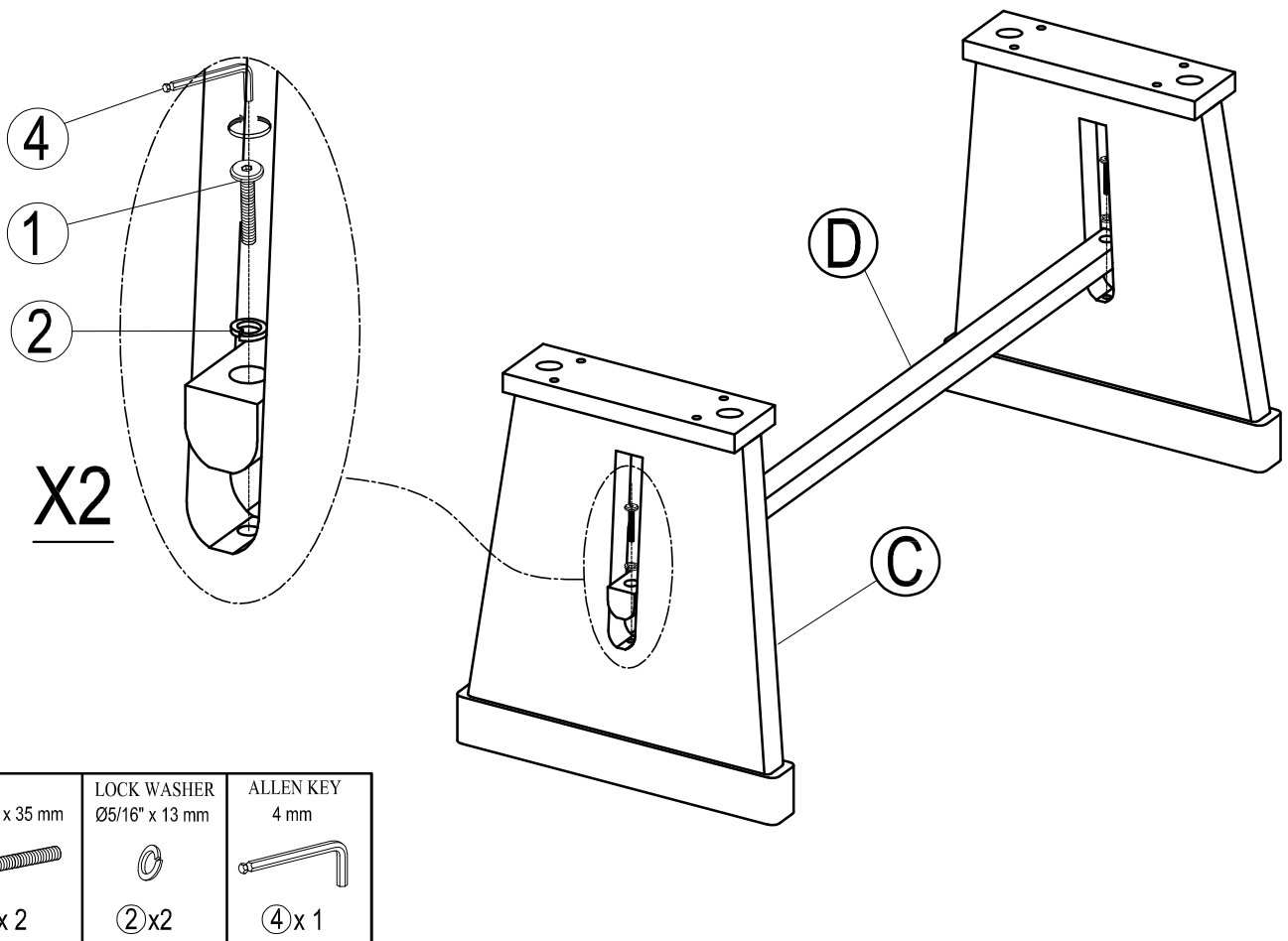



ASSEMBLY INSTRUCTION

ITEM NO.N715P406515

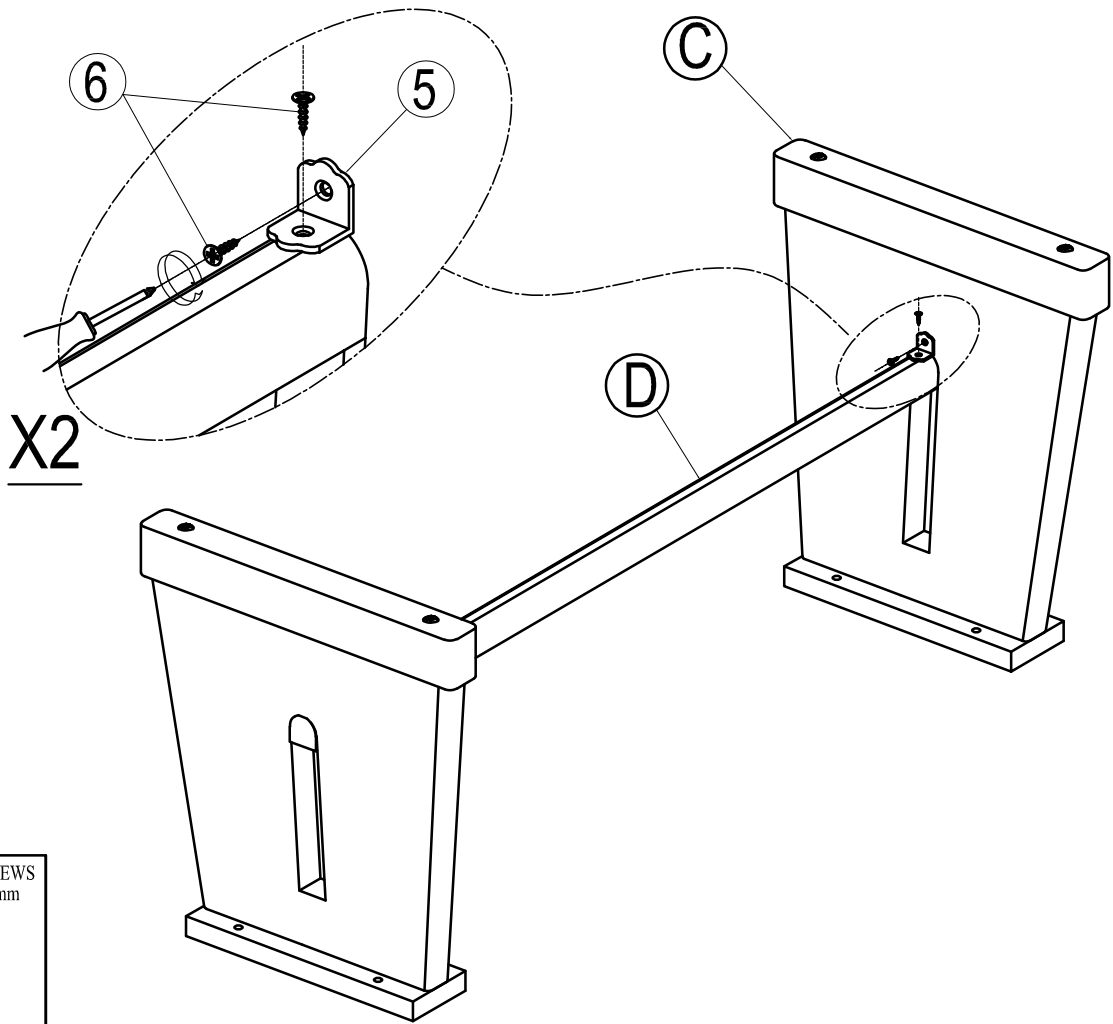



STEP 3:

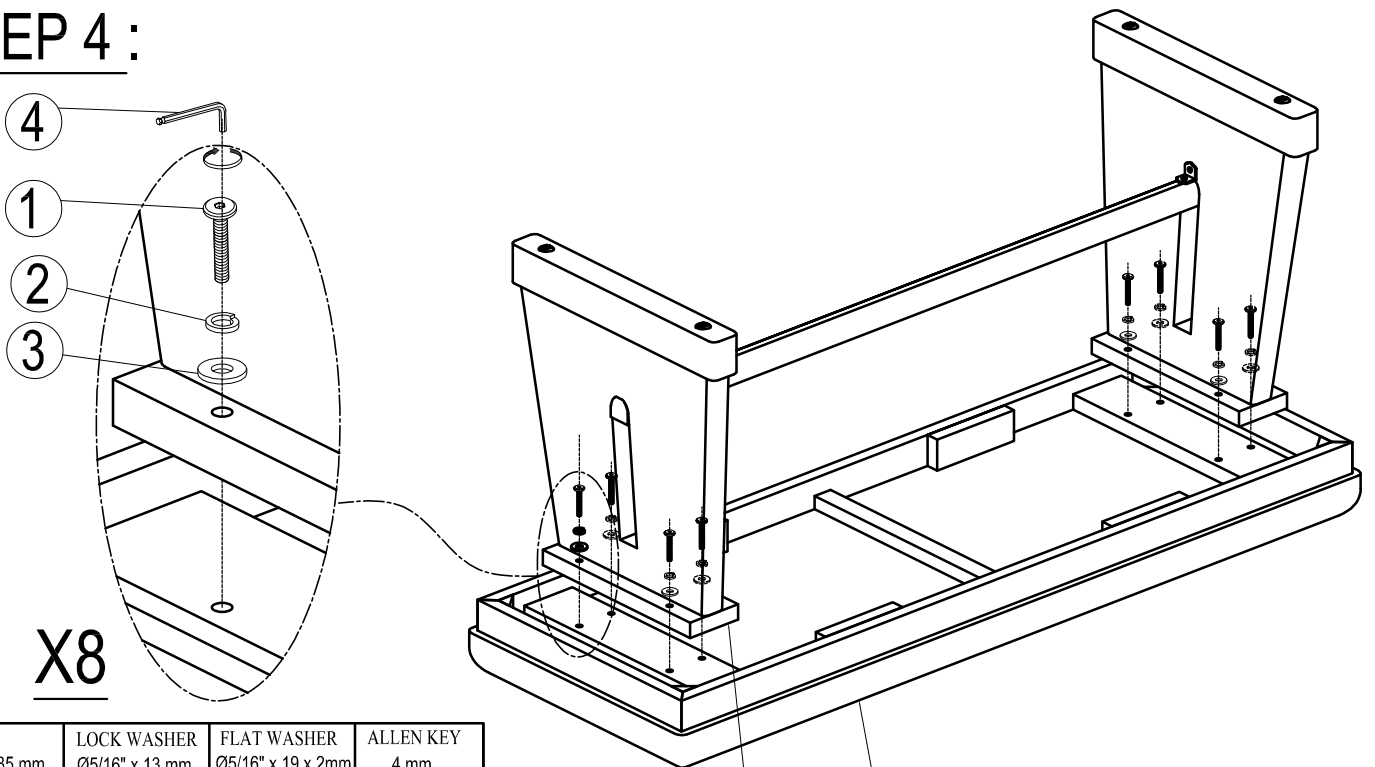

PATCH 19x18x1.5 mm	WOOD SCREWS Ø3 x 12 mm
	
⑤ x 2	⑥ x 4

STEP 4 :



BOLT Ø 1/4" x 35 mm	LOCK WASHER Ø5/16" x 13 mm	FLAT WASHER Ø5/16" x 19 x 2mm	ALLEN KEY 4 mm
			
① x 8	② x 8	③ x 8	④ x 1

ASSEMBLY INSTRUCTION

ITEM NO.N715P406515

COMPLETE

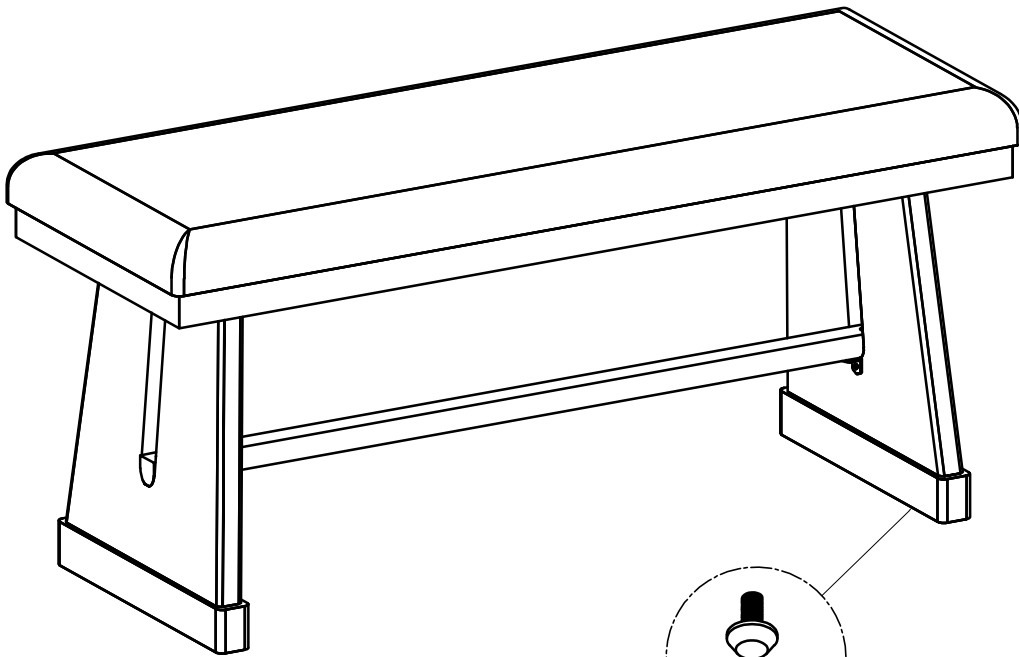

Adjust Leveler = 4 pcs