

ASSEMBLY INSTRUCTIONS

Thank you for purchasing this quality product. Be sure to check all packing material carefully for small Hardware which may have come loose inside the carton during shipment. Identify and count all hardware and compare with the hardware list below

ASSEMBLY INSTRUCTION :

1. Remove hardware from box and sort by size.
2. Please check to see that all hardware and parts are present prior start of assembly.
3. Please follow attached instruction in the same sequence as numbered to assure fast and easy.



WARNING !

1. Don't attempt to repair or modify parts that are broken or defective. Please contact the store immediately.
2. This product is for home use only and not intended for commercial establishments.
3. Two persons are required for assembly.
4. Approximate assembly time: 1/2 hours
5. Component parts and fittings contained in the box.
Please sort out all parts before you begin to assemble the item.
This is to make sure you always use the correct part
6. It is **STRONGLY RECOMMENDED** that you **ANCHOR** this product.
Toppling furniture can cause serious injuries and death.
This product has not been fitted with an anchor strap.
To prevent your furniture from tipping forward it is strongly recommended that you securely attach this product to a wall or other solid surface, using the anchor straps provided and appropriate fixings.

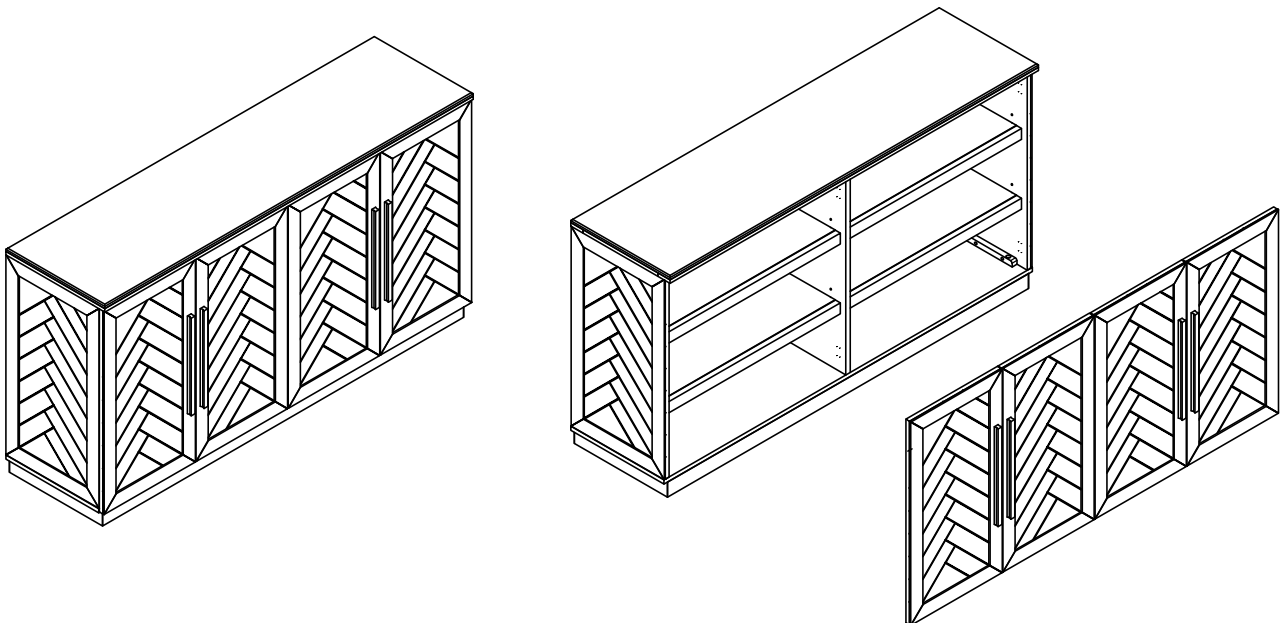

ED: Phillips Screwdriver

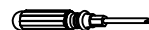

Wall Drill



Hammer

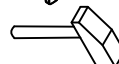

ASSEMBLY INSTRUCTIONS

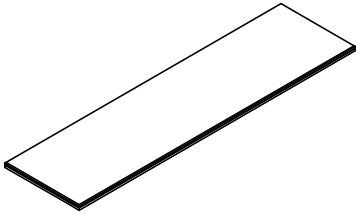

1
x1
Top panel

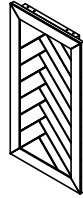

2
x1
Left side panel



3
x1
Middle panel

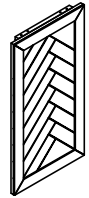

4
x1
Right side panel

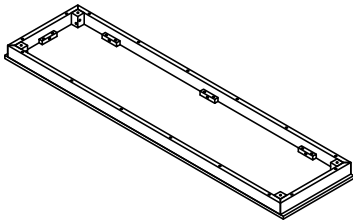

5
x1
bottom panel

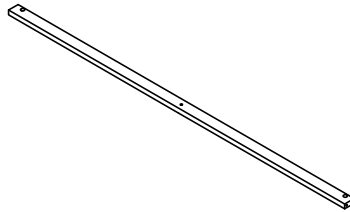

6
x1
front panel

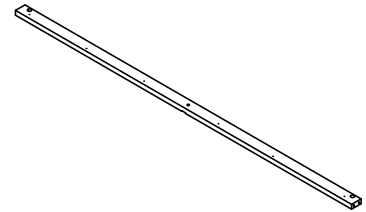

7
x2
rear panel 1

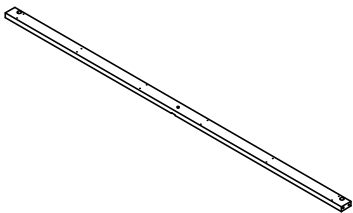

8
x1
rear panel 2

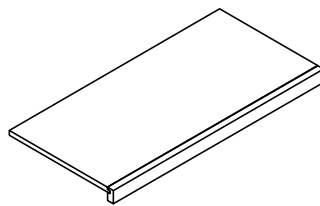

9
x4
Shelf panel

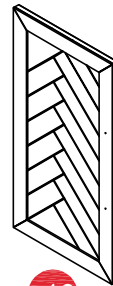

10
x2
Left door panel

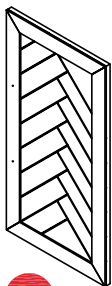

11
x2
Right door panel

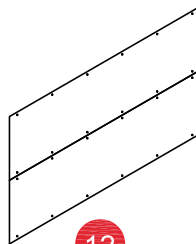

12
x1
Back panel

ASSEMBLY INSTRUCTIONS

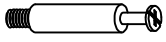

A

x8
Cam-bolts



B

x8
Cam-locks

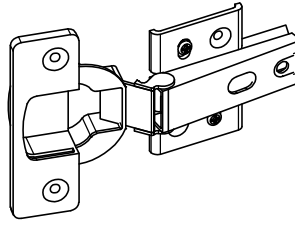

Φ35

C

x4
Hinges

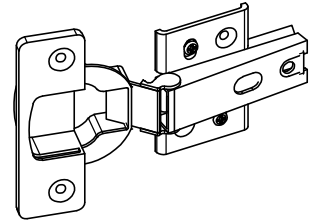

Φ35

D

x4
Hinges

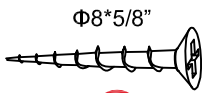

Φ8*5/8"

E

x48
Screws

5/32"* 1-1/8"



F

x8
handle bolts

13"*3/4"



G

x4
Handles

Φ8*3/4"



H

x12
Dowels

Φ8* 1-1/8"



I

x8
Dowels

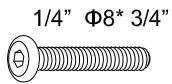

1/4" Φ8* 3/4"

J

x12
Bolts

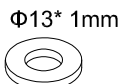

Φ13* 1mm

K

x12
Flat Washer

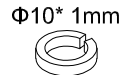

Φ10* 1mm

L

x12
Spring Washer



4mm

M

x1
Allen Key

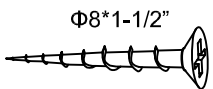

Φ8*1-1/2"

N

x4
Screws

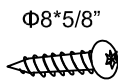

Φ8*5/8"

O

x24
Screws



P

x4
Hook



R

x4
Anchor



S

x2
Plastic tie

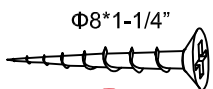

Φ8*1-1/4"

U

x4
Screws

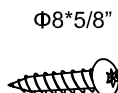

Φ8*5/8"

V

x4
Screws

1/4*20



W

x4
increase and decrease below

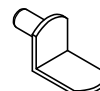

X

x16
Shelf supports

ASSEMBLY INSTRUCTIONS

STEP 1

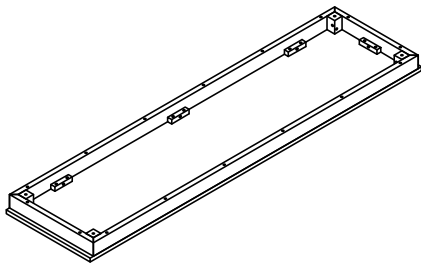
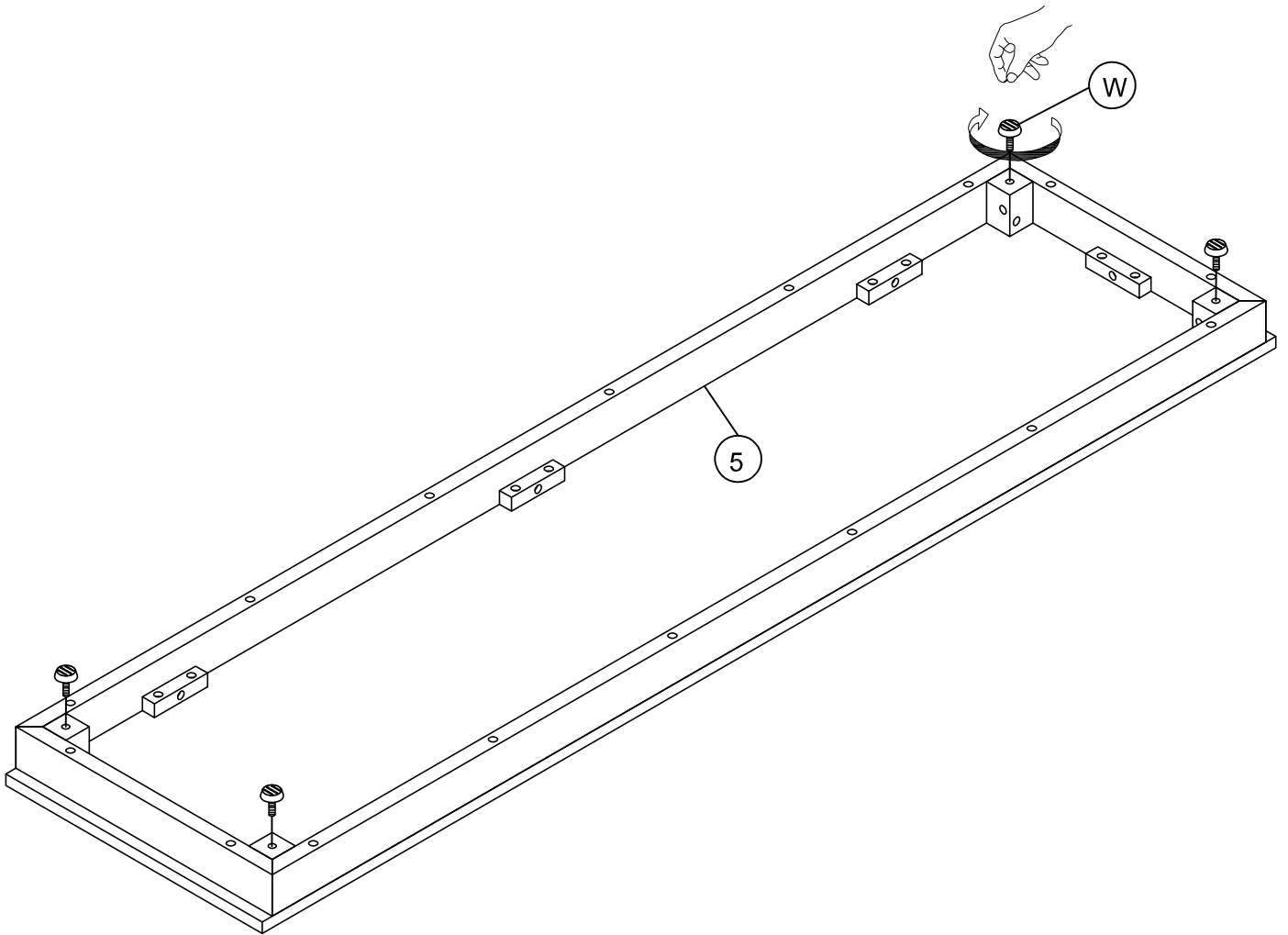

5

x1

bottom panel



W

x4

increase and
decrease below

ASSEMBLY INSTRUCTIONS

STEP 2

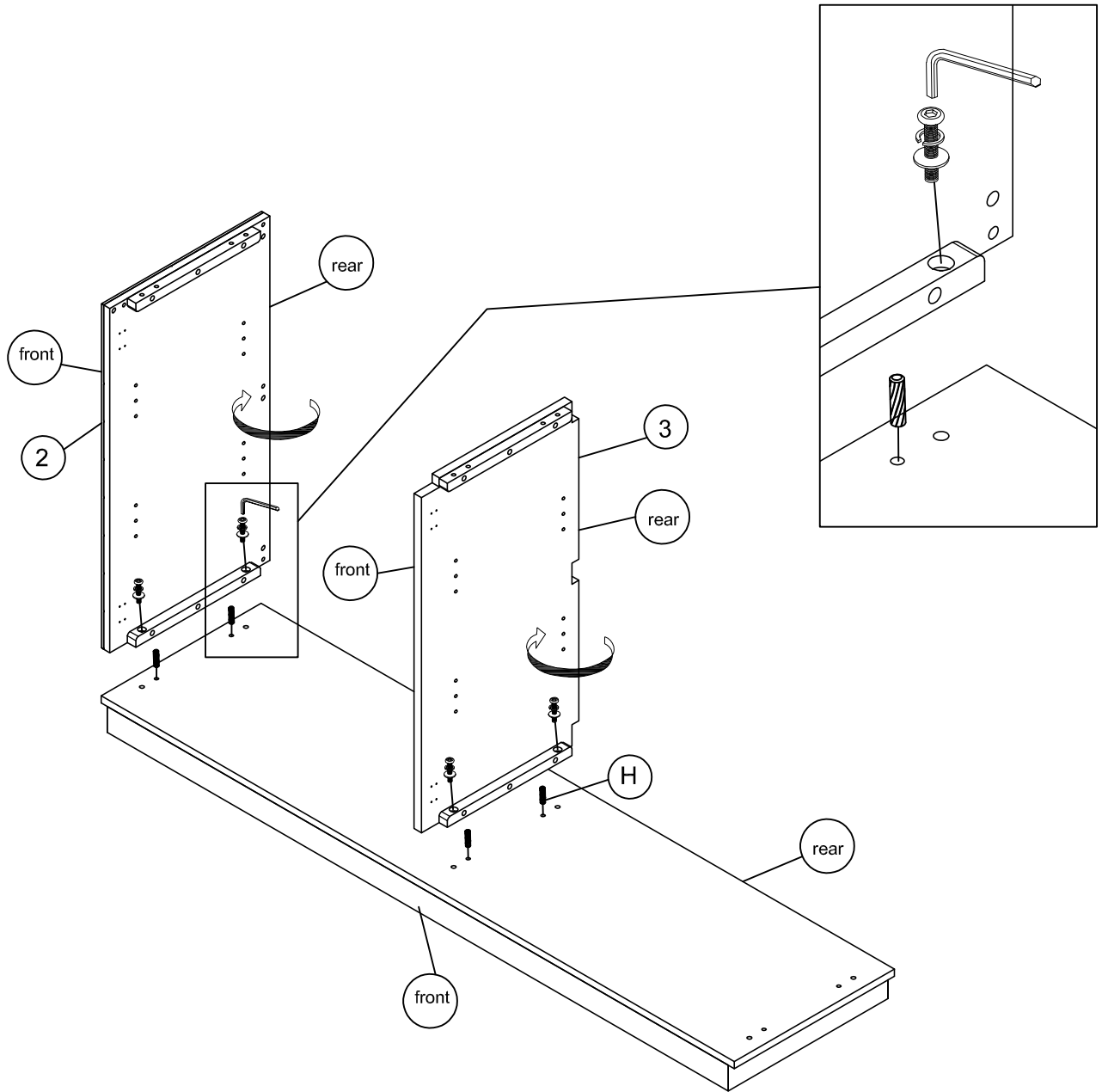

2 x1 Left side panel	3 x1 Middle panel	H x4 Dowels	J x4 Bolts
K x4 Flat Washer	L x4 Spring Washer	M x1 Allen Key	

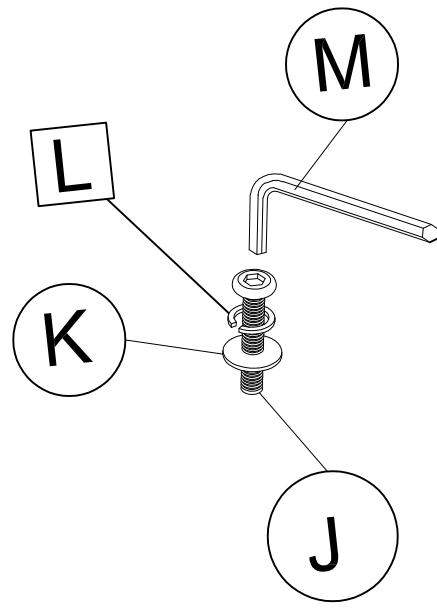

ASSEMBLY INSTRUCTIONS

STEP 3

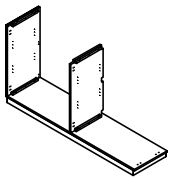
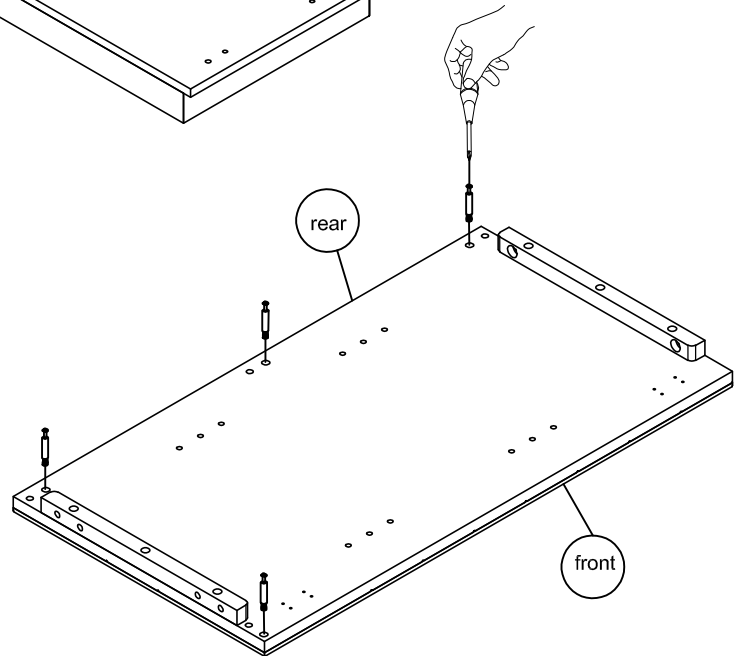
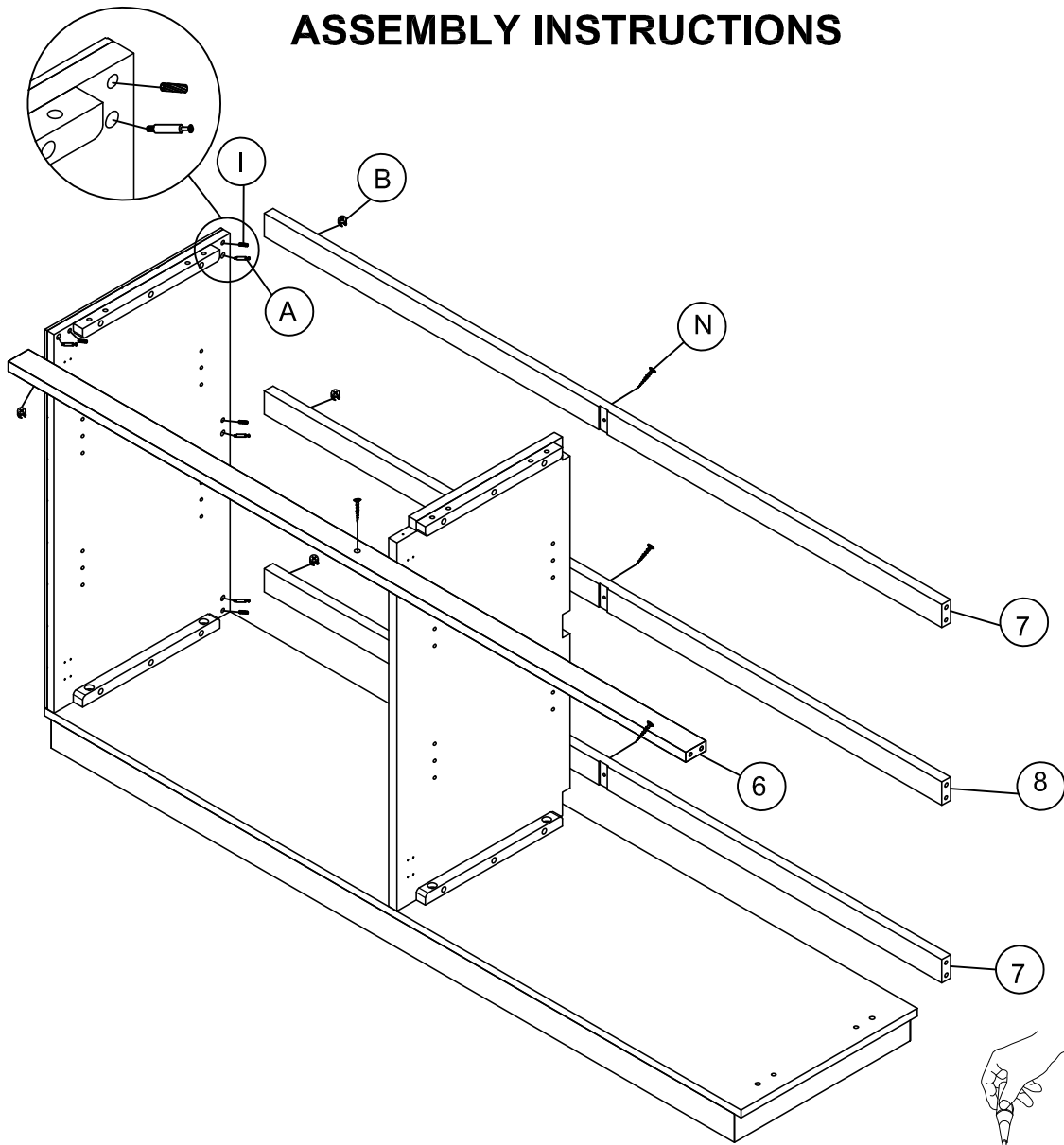

6

x1

front panel

7

x2

rear panel 1

8

x1

rear panel 2



A

x4
Cam-bolts



B

x4
Cam-locks



I

x4
Dowels

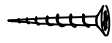

N

x4
Screws

ASSEMBLY INSTRUCTIONS

STEP 4

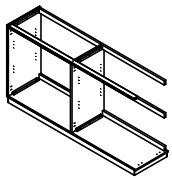
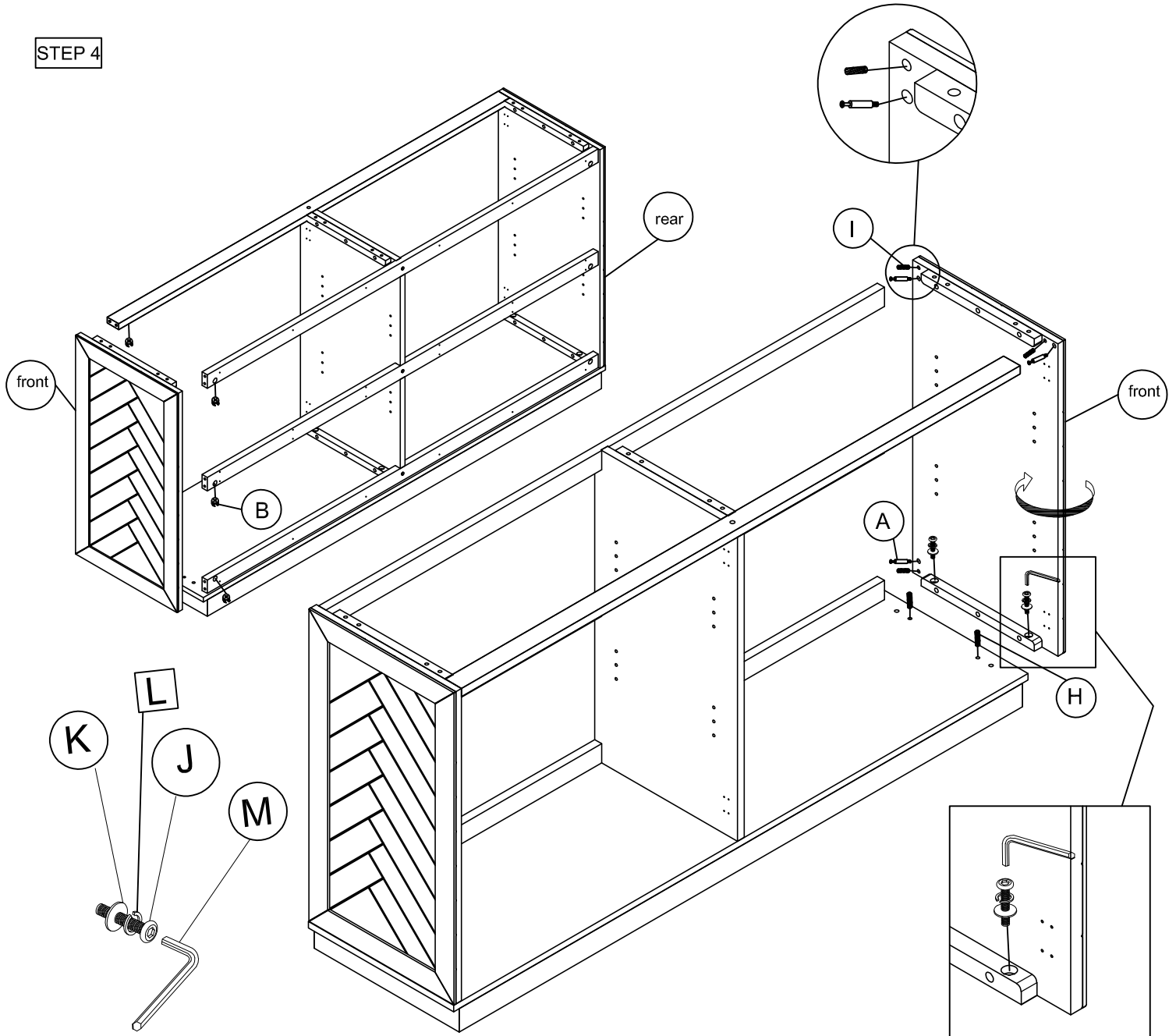

x1

Right side panel



A

x4
Cam-bolts



B

x4
Cam-locks



H

x2
Dowels



I

x4
Dowels



J

x2
Bolts



K

x2
Flat Washer



L

x2
Spring Washer



M

x1
Allen Key

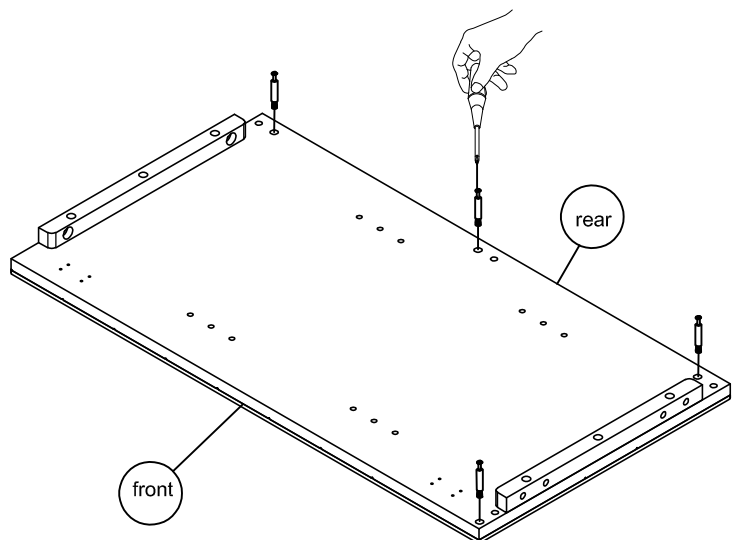

ASSEMBLY INSTRUCTIONS

STEP 5

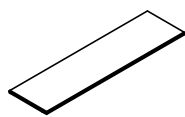
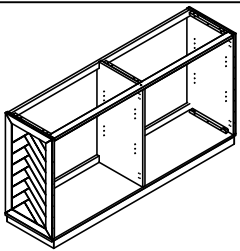
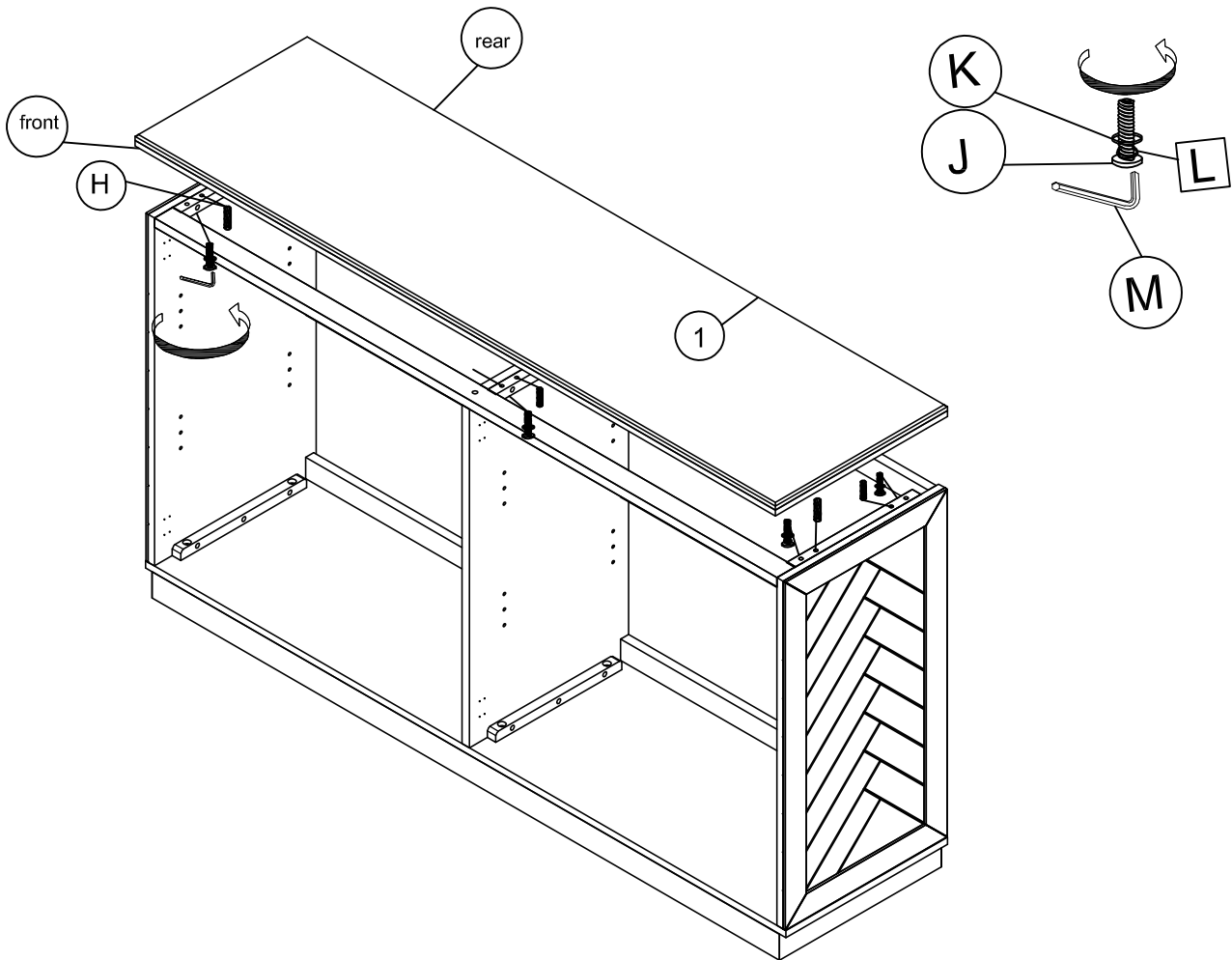

1
x1

Top panel



H

x6
Dowels



J

x6
Bolts



K

x6
Flat Washer



L

x6
Spring Washer



M

x1
Allen Key

ASSEMBLY INSTRUCTIONS

STEP 6

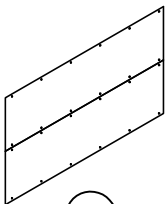
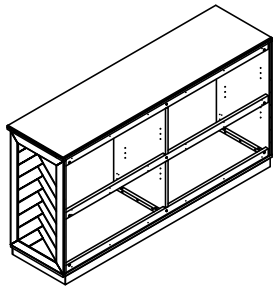
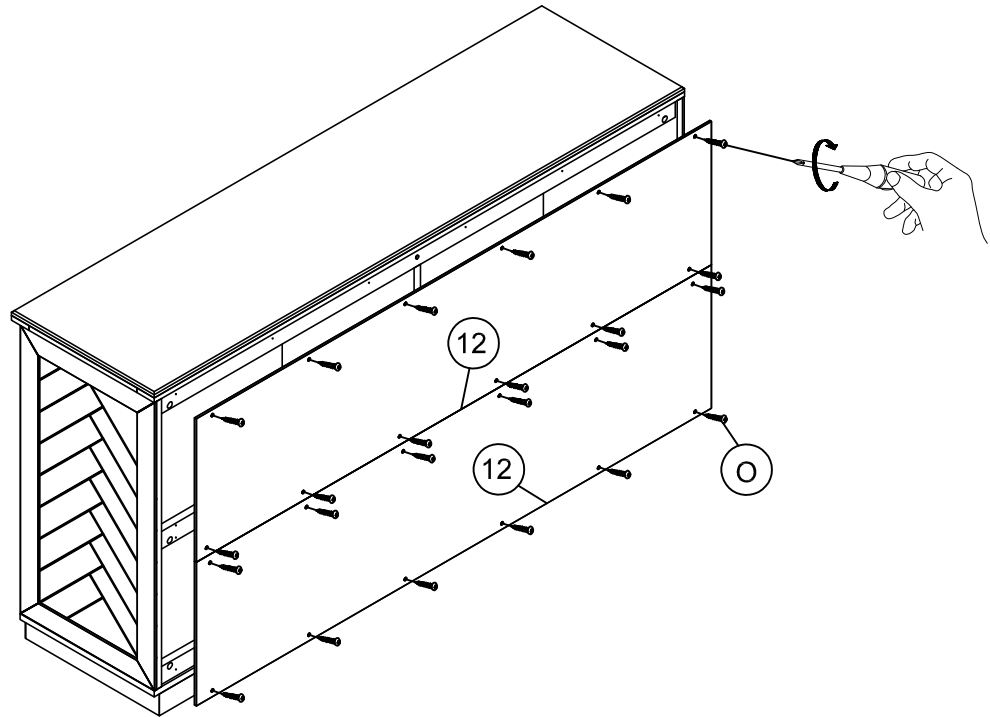

x1
Back panel

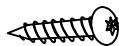

x24
Screws

ASSEMBLY INSTRUCTIONS

STEP 7

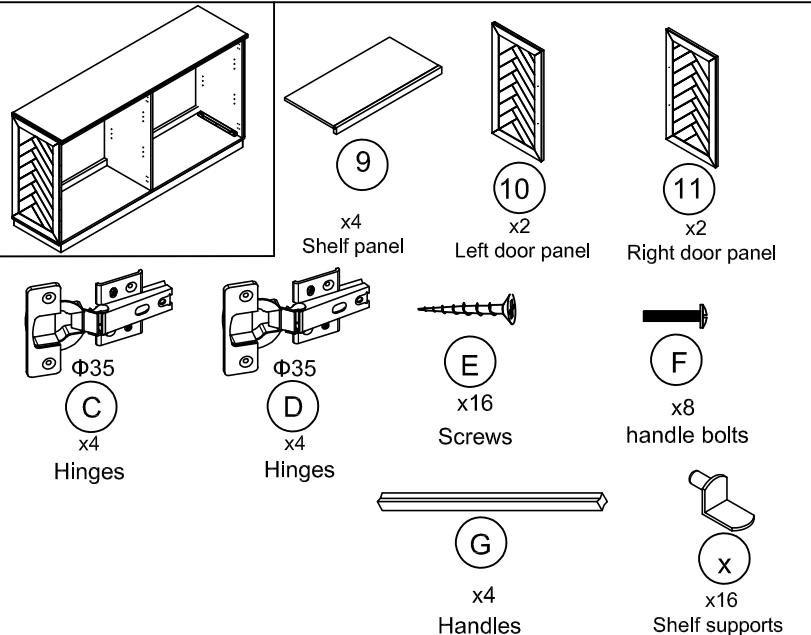
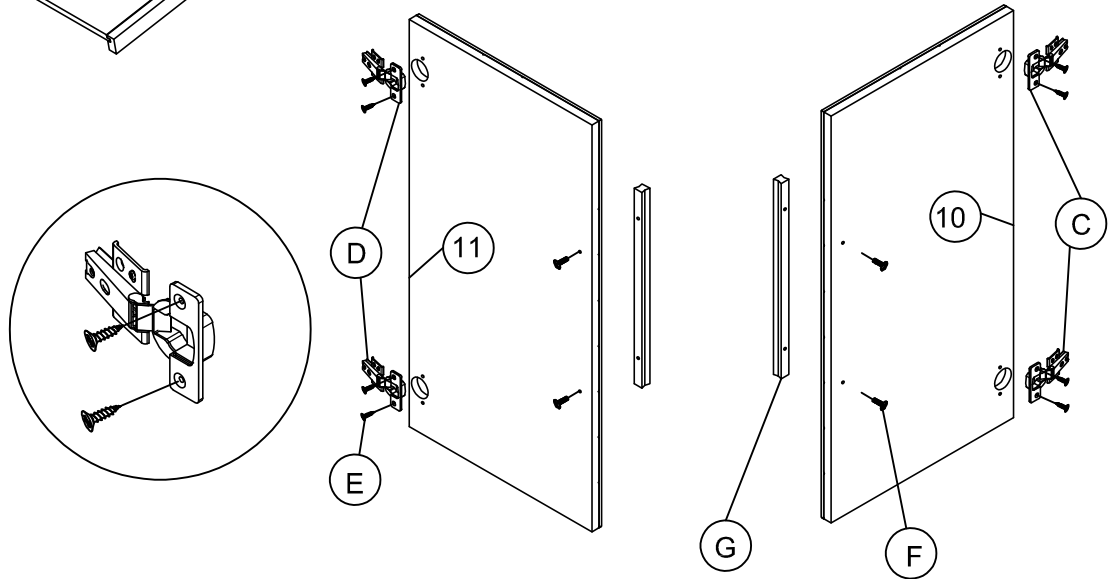
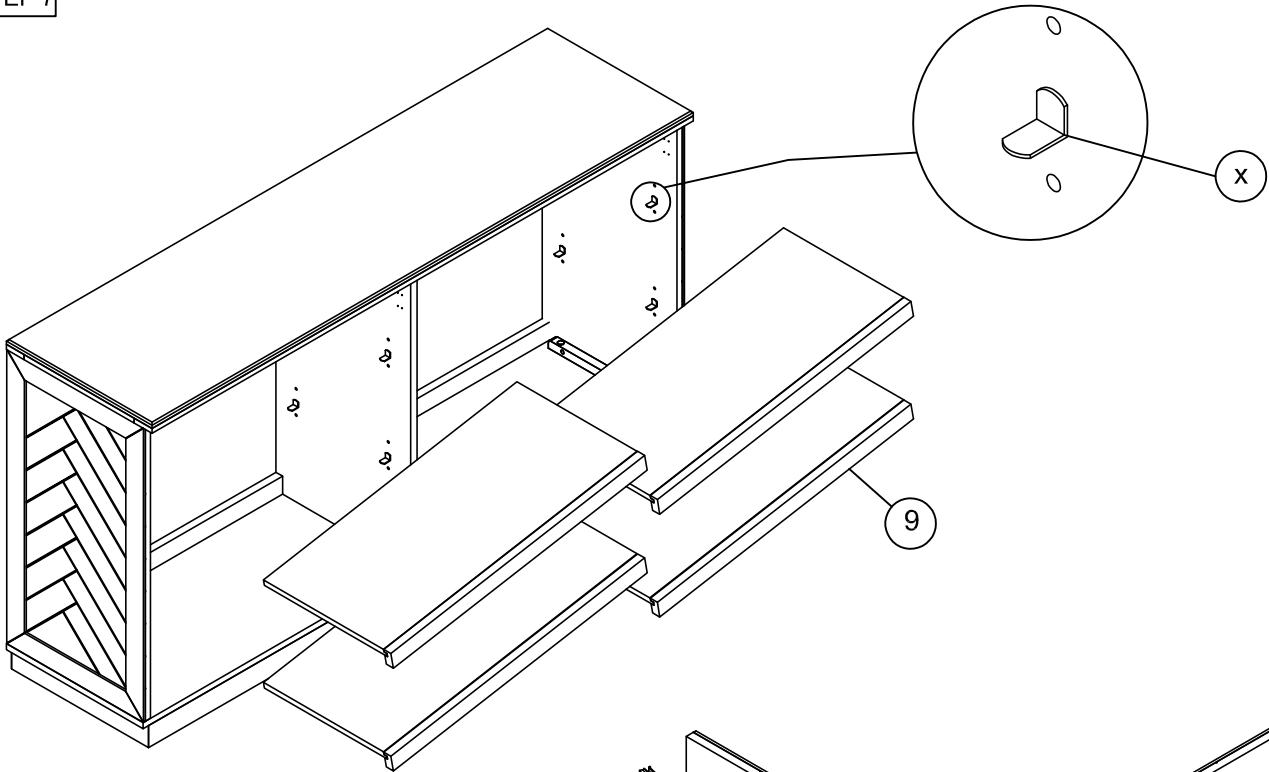

ASSEMBLY INSTRUCTIONS

STEP 8

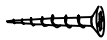
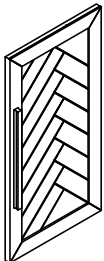
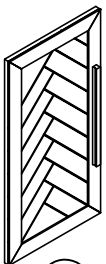
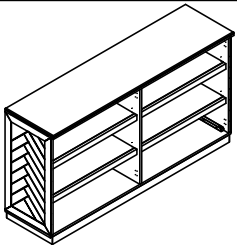
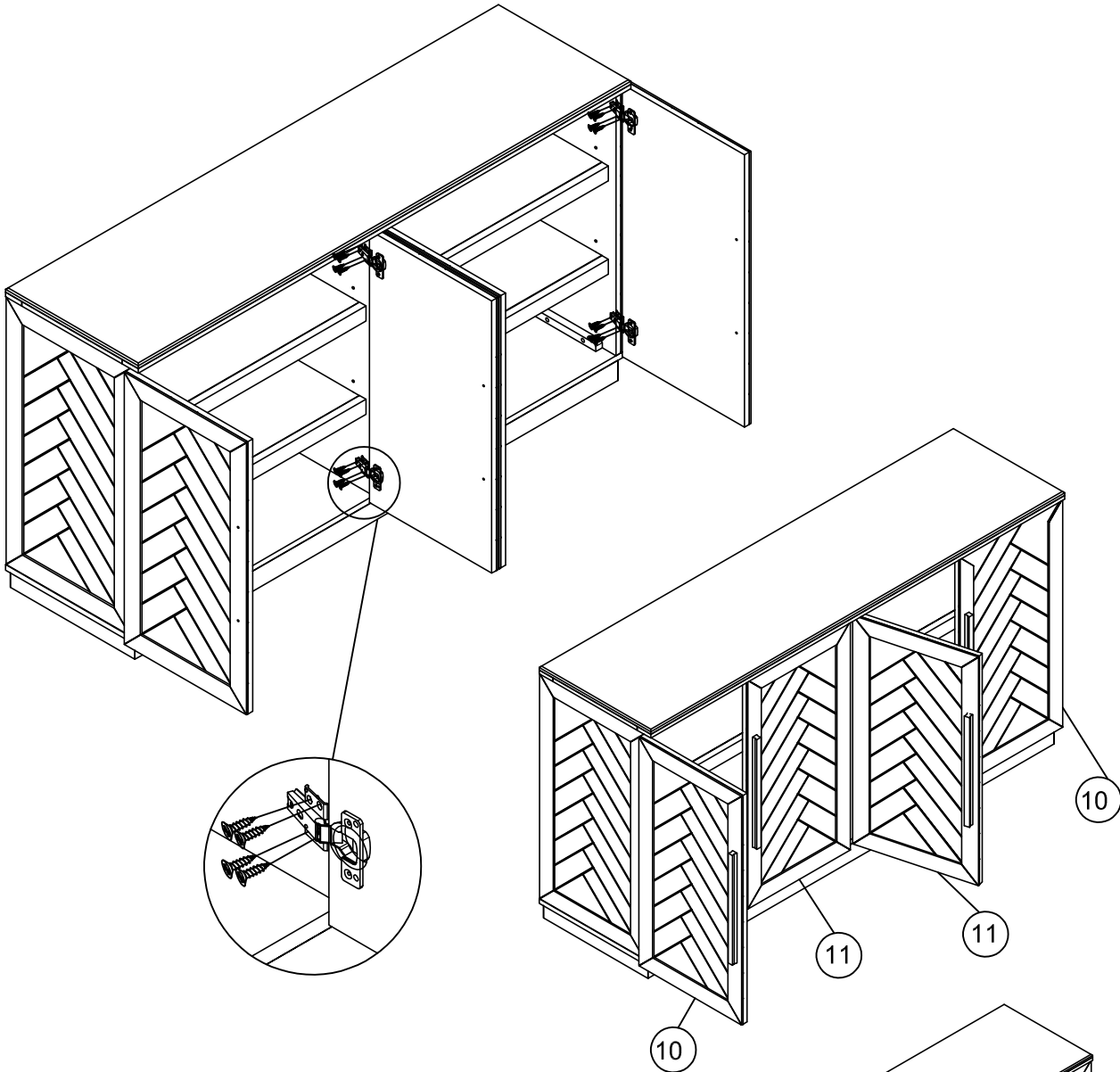

10

x2

Left door panel

11

x2

Right door panel

E

x32

Screws

ASSEMBLY INSTRUCTIONS

STEP 9

Place the Cabinet in the desired location against the wall. Mark the position of the attached Hooks (P) on the wall and remove the Cabinet. Using one of the remaining Hooks (P) as a template, Place the Hook (P) under the marks on the wall and mark the two hole positions. Drill the holes for the Anchors (R) and insert the Anchors (R) into the wall. Attach the remaining Hooks (P) to the Anchors (P) with Screw (U). Fully tighten the screws. Return the Cabinet to the selected position and connect the Hooks (P) together with Plastic Tie (S). Assembly is now complete.

