

ASSEMBLY INSTRUCTION

ASSEMBLY TIPS:





- 1.Remove hardware from box and sort by size.
- 2.Please check to see that all hardware and parts are present prior to start of assembly.
- 3.Please follow attached instructions in the same sequence as numbered to assure fast & easy assembly.





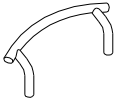

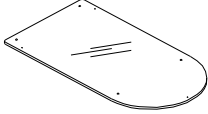
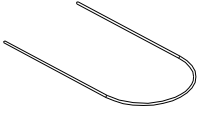

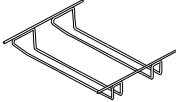
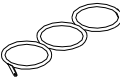





Warning =:

- 1.Don't attempt to repair or modify parts that are broken or defective.Please contact the store immediately.
- 2.This product is for home use only and not intended for commercial establishment.



PARTS IDENTIFICATION

(A) HAND RAIL		1PC	(CR) RIGHT SIDE FRAME		1PC
(B) GLASS		2PCS	(D) U FRAME		2PCS
(CL) LEFT SIDE FRAME		1PC	(E) GLASS HOLDER		1PC
			(F) BOTTLE HOLDER		1PC

HARDWARE PACKAGE

NO	DESCRIPTION	FIGURE	Q'TY	NO	DESCRIPTION	FIGURE	Q'TY
1	PLASTIC SPACER		6pcs	7	LARGE WASHER		4pcs
2	BOLT CAP		2pcs	8	SMALL PLASTIC WASHER		12pcs
3	LONG CROSS HEAD BOLT		6pcs	9	CAP		2pcs
4	SHORT BOLT		2pcs	10	SHORT CROSS HEAD BOLT		2pcs
5	LARGE BOLT		2pcs	11	LARGE PLASTIC WASHER		2pcs
6	SMALL WASHER		6pcs	12	ALLEN KEY		1pc

HARDWARE PACKAGE 2

13	CASTER		2pcs 2pcs	14	WRENCH		1pc
----	--------	---	--------------	----	--------	---	-----

You will need one people for this installation. And will take about forty-five minutes.

STEP 1

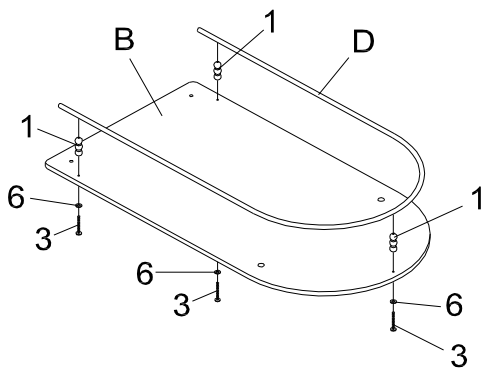

STEP 2

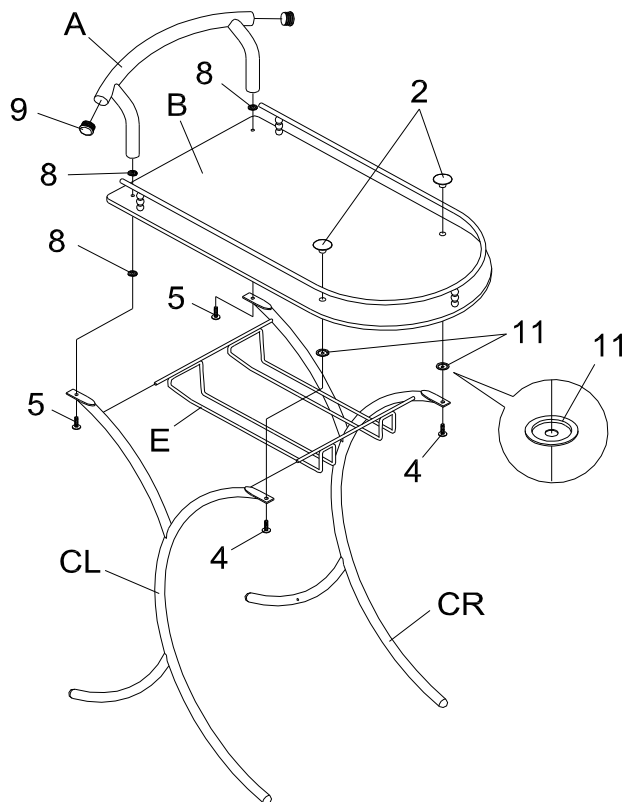

STEP 4

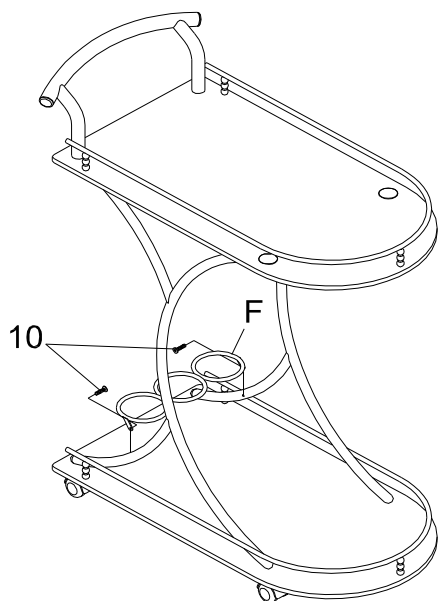

STEP 3

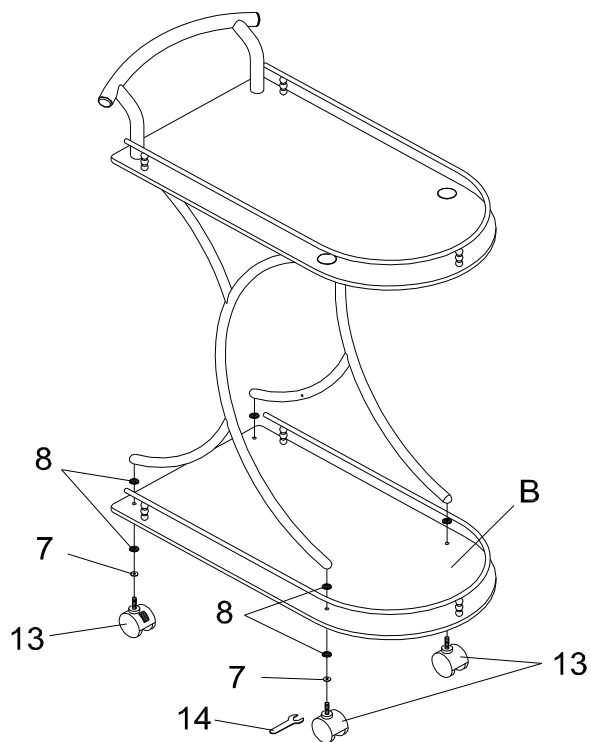

FINISH

