

# ASSEMBLY INSTRUCTIONS

Before you commence the assembly process, we recommend that you read these instructions thoroughly beforehand to familiarise yourself with the assembly process and to also check that you have the correct components. If for any reason you need assistance, you can find our contact details on the final page of these instructions.

We highly recommend that any assembly is carried out on an open flat, level surface if possible, with sufficient space. You will also require the assistance of up to 2 adults to complete assembly safely.







- Please note:**
- 1) You can remove up to 600mm from the bottom of each post prior to commencing construction. Remember to also adjust the height of your wall plate accordingly.
  - 2) Wall fixings are not included.

## Tools required:

10mm socket, No2 Pozidriv screwdriver (or electric driver), step ladder or platform.

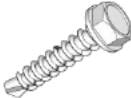
## Components

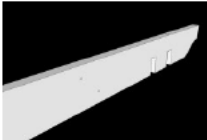
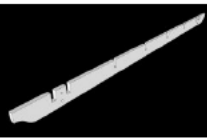
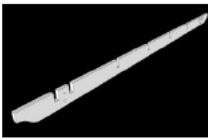
The components listed below are those required to build a Wall Mounted Double Premium pergola of 3M in size or larger. For the 2.4M version there are only 3 rafters and 28 x 120mm coachscrews. \*An extra post is included in the 3-post version.

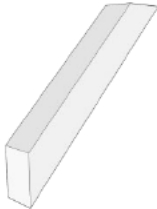
32 x 60mm woodscrews	16 x 70mm woodscrews	16 x 70mm coachscrews	16 x 120mm coachscrews	8 x Post cladding panels	4 x Rafters
					
4 x Pre-drilled end Rafters	2 x Pre-drilled Runners	1 x wall plate	2 x Posts*	4 x Braces	
					

# RUTLAND WALL MOUNTED DOUBLE PREMIUM PERGOLA

## Step 1

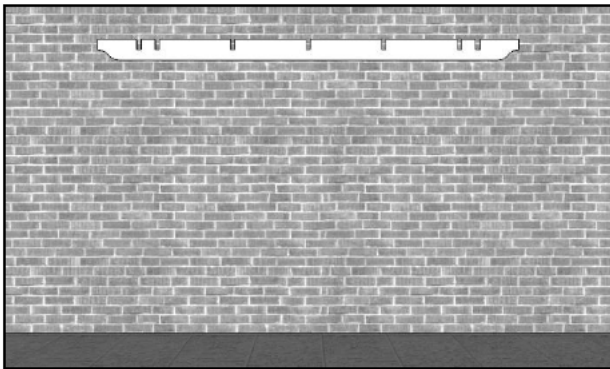

Check that you have the correct components as shown in the package contents, including any fixings.  
Take the pre-drilled wall plate with the slots on the top edge and place it (use a spirit level or laser) on the wall where you would like the pergola located. Mark the hole positions for your wall fixings then drill and fix in place.  
**Note:** The distance from the top of the wall plate to the floor should be equal to the height of the post above ground level.

## Step 2

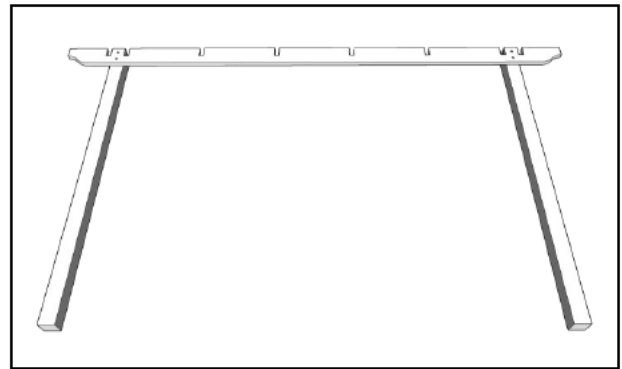

Next, lay two of the posts on a flat surface as shown and then place one of the runners, countersinks uppermost, on top of the posts with the outer notches over the post as shown.

## Step 3

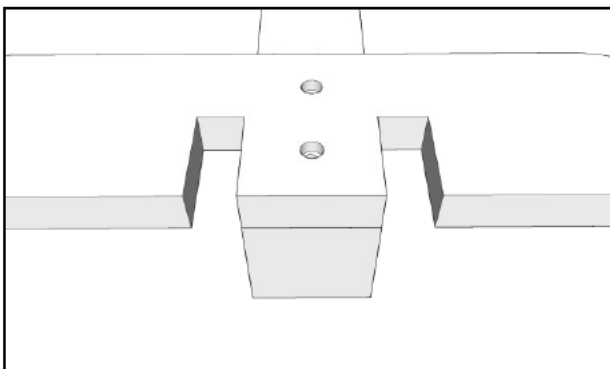

At this point ensure that the post is aligned between the notches, flush with the top edge of the runner and perpendicular to it.

## Step 4

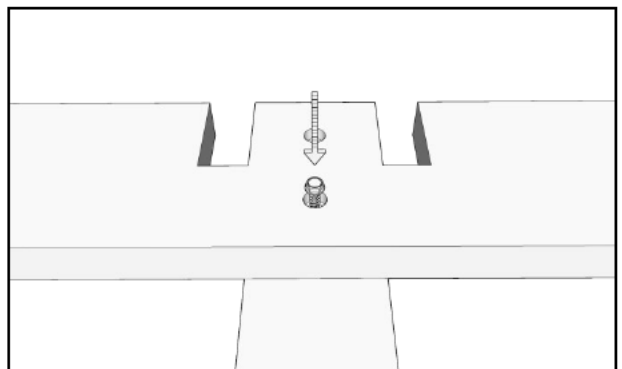

Now insert a 70mm coachscrew into one of the holes in the runner and drive it into the post using a socket and ratchet or driver until almost fully home.

# WALL MOUNTED DOUBLE PREMIUM PERGOLA

## Step 5

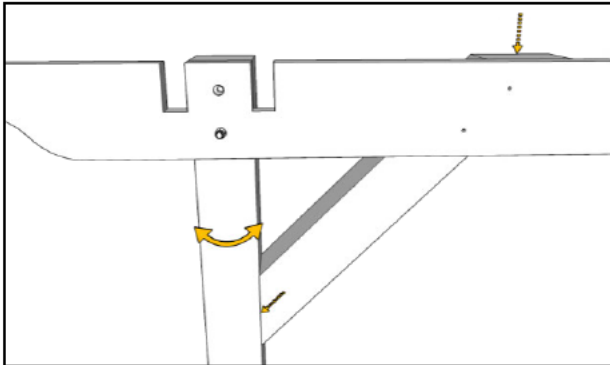

Position one of the braces against the side of the post as shown with the bolt countersink adjacent to the post. Check that the top edge of the brace is flush with the top edge of the runner and that the lower face is flat against the post. If necessary, alter the position of the post to achieve this by pivoting it on the bolt inserted in the previous step.

## Step 6

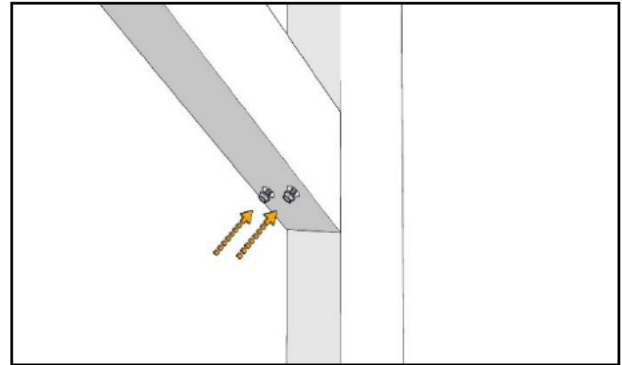

Once the brace is correctly positioned insert 2 x 70mm coachscrews and fix to the post by driving them fully home with the socket or driver.

## Step 7

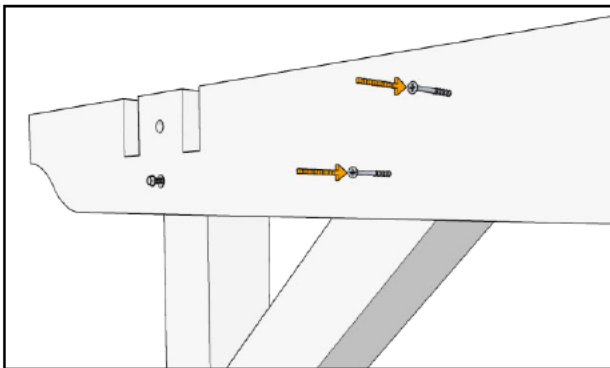

Now secure the other end of the brace to the runner with 2 x 70mm woodscrews.

## Step 8

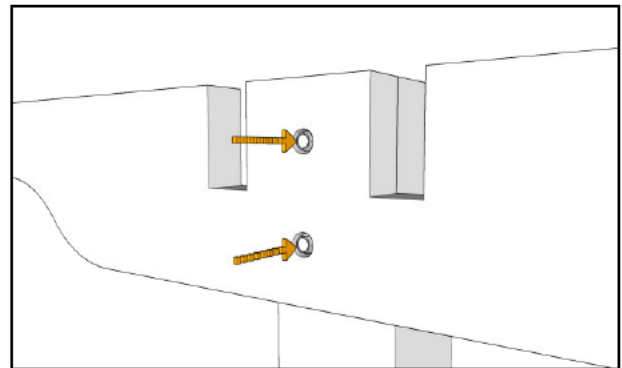

Insert a second 70mm coachscrew into the hole in the runner and drive both coachscrews fully home. Repeat the previous steps to attach the second post to the runner.

# WALL MOUNTED DOUBLE PREMIUM PERGOLA

## Step 9

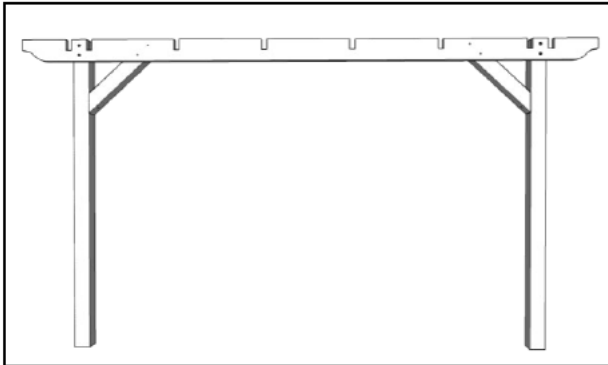

Take the completed assembly and turn it over to commence fitment of the second runner and brace. **IMPORTANT NOTE** - on the inner face of the runner notches you will find one marked with a star - these should always be placed at the same end of the assembly.

## Step 10

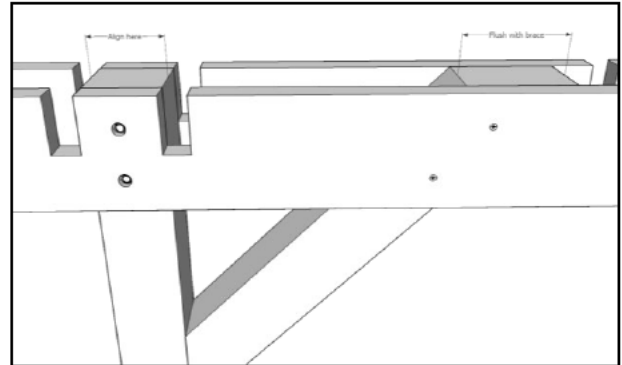

Place the next runner as you did previously, carefully aligning it, prior to attaching to the post and brace as before.

## Step 11

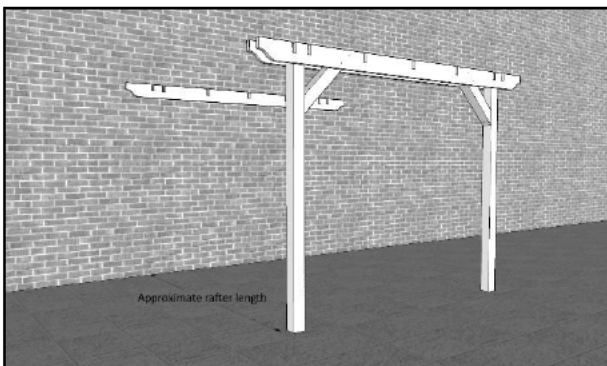

Using your assistants, lift the frame assembly into the vertical position, aligned with the runner and approximately the length of a rafter from the wall.

## Step 12

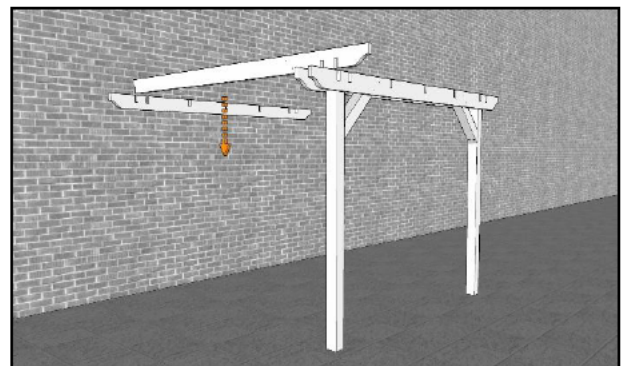

Now lift the first pre-drilled rafter into place, slotting each end into the outermost slot in the runner/wall plate (if the joint is tight use a mallet or hammer with wood block to gently tap the rafter into place)...

# WALL MOUNTED DOUBLE PREMIUM PERGOLA

## Step 13

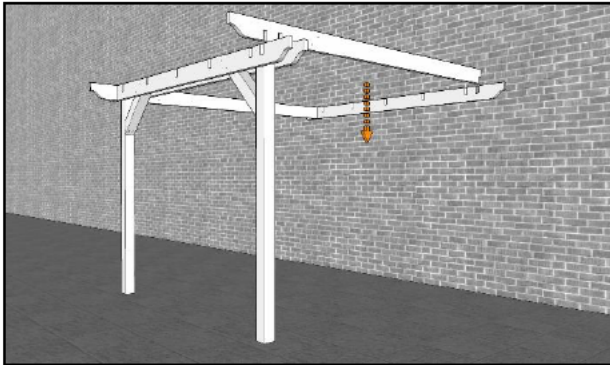

And repeat for the second rafter, this time at the outermost slot of the opposite end of the pergola.

## Step 14

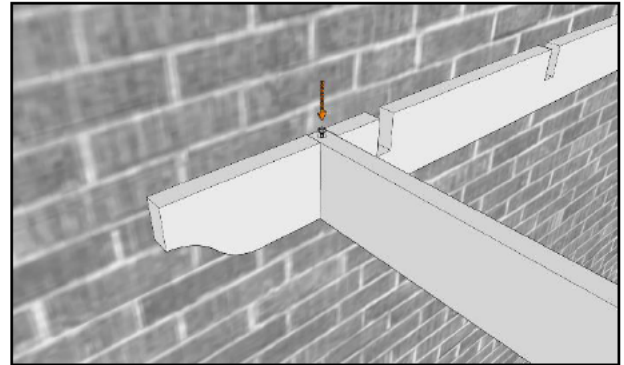

Secure the rafter to the wall plate with a 120mm coach screw driven in from above....

## Step 15

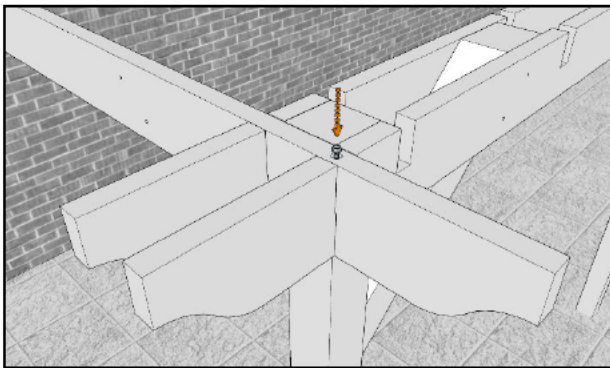

...and into the runner using a 120mm coach screw.

## Step 16

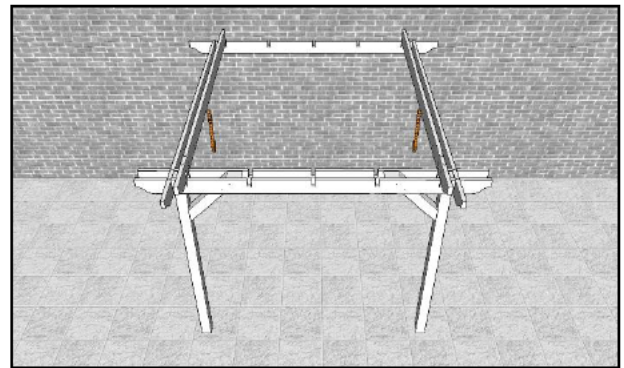

Now add the next two innermost rafters in the same fashion...

# WALL MOUNTED DOUBLE PREMIUM PERGOLA

## Step 17

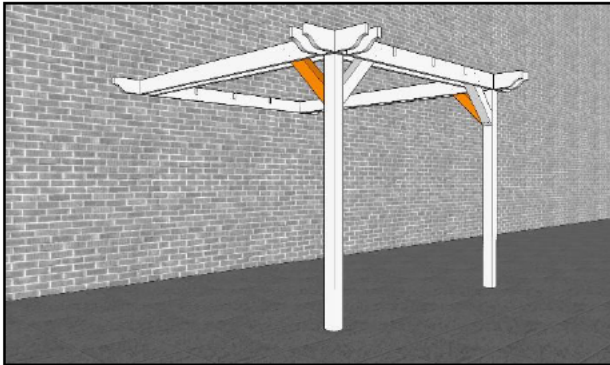

...before adding the remaining braces, ensuring they are flush with the post edge and rafter tops, then securing into place with 2 x 70mm coachscrews and 4 x 75mm screws.

## Step 18

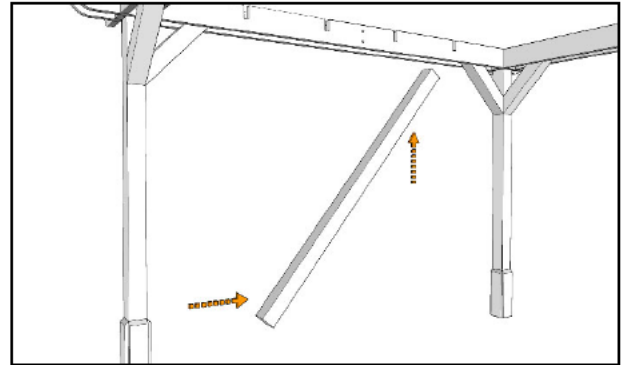

If you are building a 3-post version take the intermediate post and manoeuvre it into position by sliding it between the runners as shown...

## Step 19

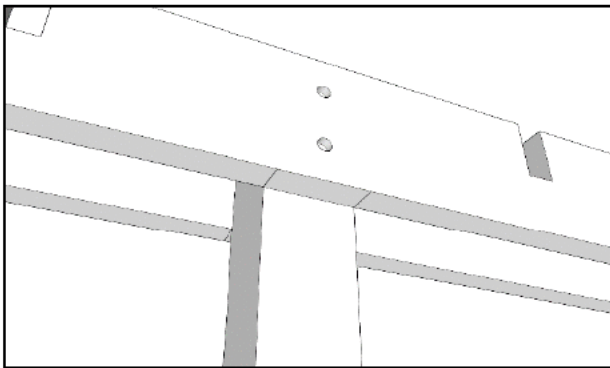

...lining it up with the markings on the runners as indicated.

## Step 20

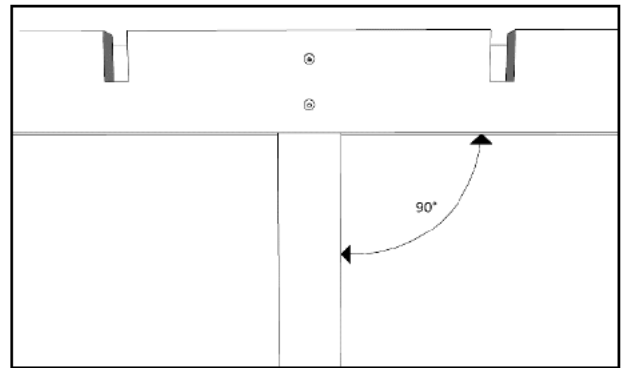

Use a spirit level to make sure the post is vertical and at 90° to the runner before fixing into place with 2 coachscrews through each runner.

# WALL MOUNTED DOUBLE PREMIUM PERGOLA

## Step 21

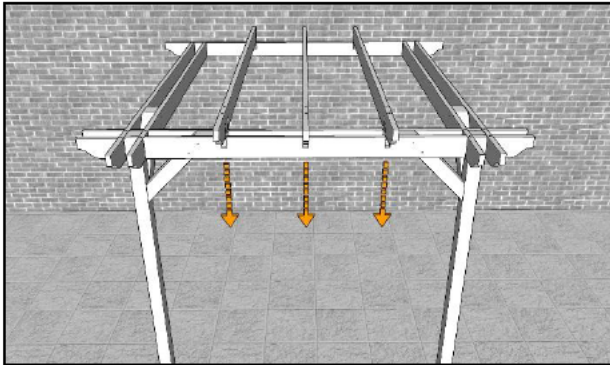

Drop the remaining rafters into place and secure in the same manner as before with a 120mm coachscrew at each end.

## Step 22

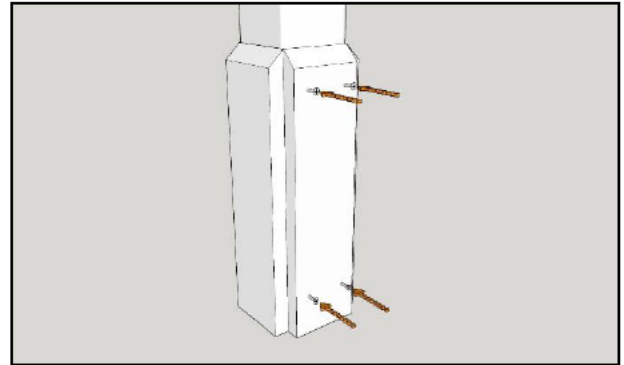

Finally attach a pedestal panel to each face of the posts, aligning them with the post and securing each panel with 4 x 60mm screws.

## Step 23

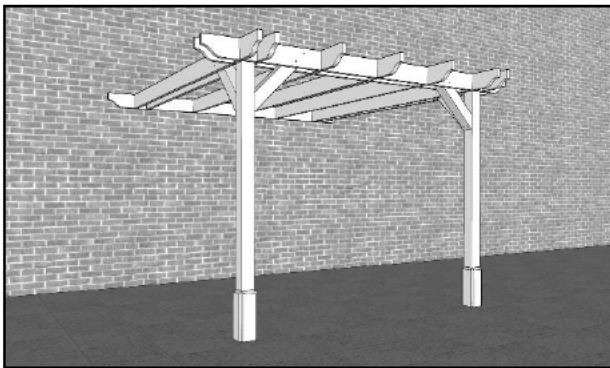

Your Wall Mounted Premium Pergola is now complete.