

HAPPINESS HAPPINESS INSTALLATION



CAUTION

Parts are placed at the bottom of the product.

- If you have any questions with the product, please contact us by:
- **Email: customerservice@zoy-living.com**
(we will reply to you within 24 hours)

Assembly Instructions



Model: RR5648AF51D

CAUTION

DO NOT use any sharp objects to open plastic wrapped components as this may result damage to product or components .

Your recliner and sofa come packaged in Two boxes. Carefully remove all components from the packaging and set them aside for assembly.

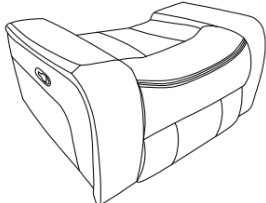
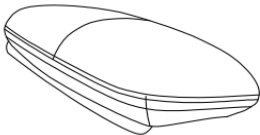
Package Contents

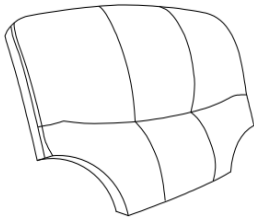
BOX 1 RR5648AF51D				
	A Seat*1	B Right Armrest*1	C Left Armrest*1	
BOX 2 RR5648AF51D				
	D Sofa Back*1			

1 RECLINER ASSEMBLY - BODY SETUP

STEP1:

As shown in the picture, first zip up the **Armrest (B&C)** to secure it to the armrest, and then firmly attach the Velcro strip on the inside of the armrest.

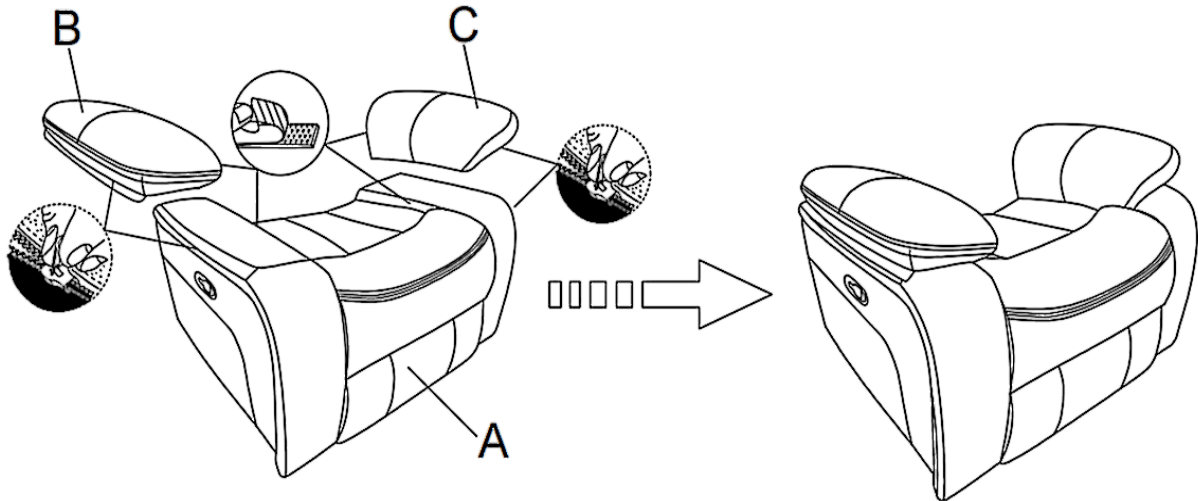

STEP2:

Connect the **Sofa Back(D)** to the **Seat(A)** by aligning the metal grooves and sliding down to the bottom.

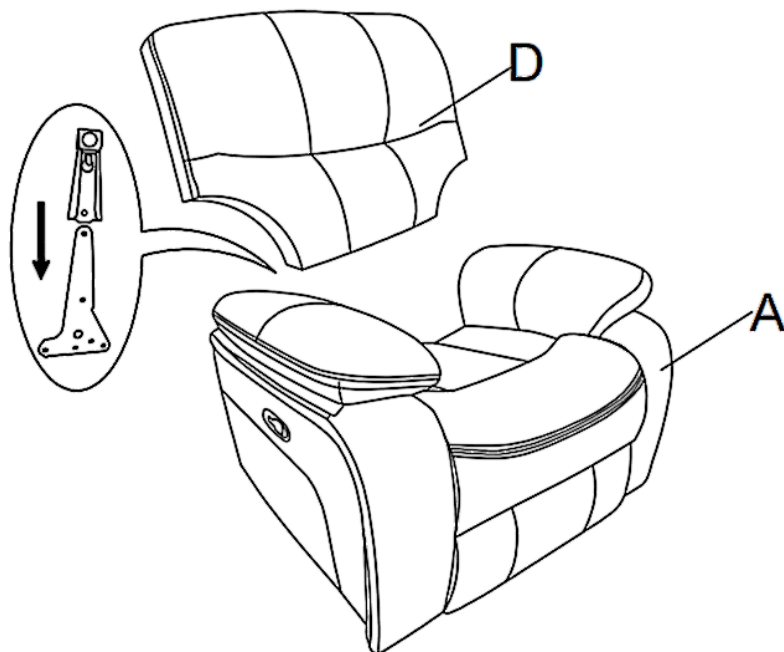

2 RECLINER ASSEMBLY - BODY SETUP

ASSEMBLY COMPLETED

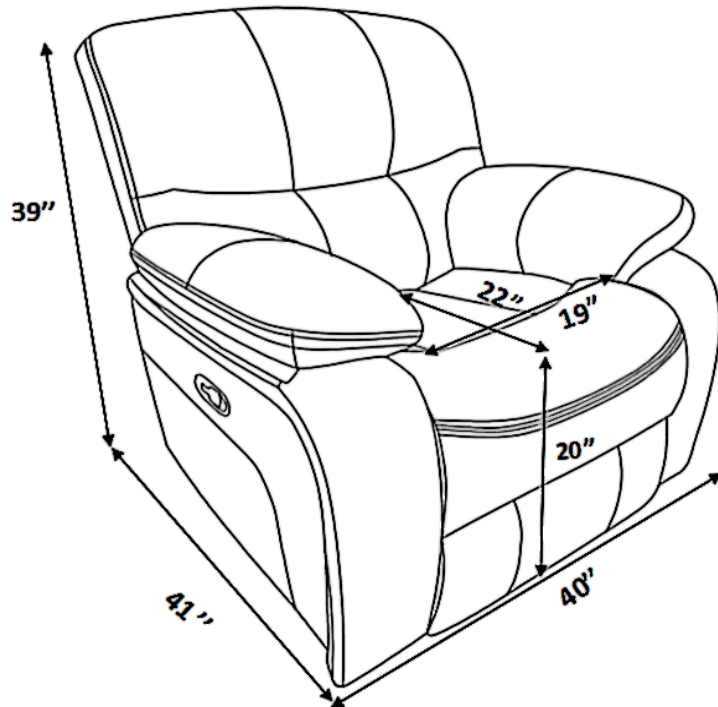
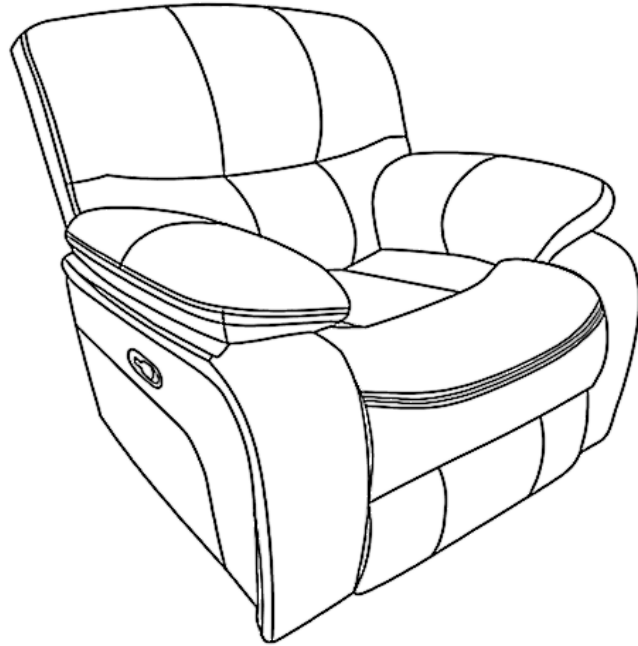

Recliner Chair

RR5648AF51D

⚠️ WARNINGS

1. Please check if the components of the chair are all included and can be used normally.
2. Assemble all components according to the instruction correctly before you sit in the chair .
3. Please DO NOT sit on the armrests or footrest to eliminate the risk of tipping over.
4. If the chair is damaged or doesn ' t match the website description, please send clear pictures of the product and label of the carton to our service team for further help.
5. If the recliner doesn ' t work, you may try the following measures for self-checking firstly:
 - a) check if all the cables are connected;
 - b) check if the light of transformer is on.If the chair still doesn ' t work, please feed the information back to our customer service in time and we will help you solve the matter as soon as possible.
6. If you have any questions about our products, please contact us by:
Email:customerservice@zoy-living.com(we will respond to your inquiry with in 24 hours)

