

ARTERIOS

ALJONA SWIVEL CHAIR CREAM

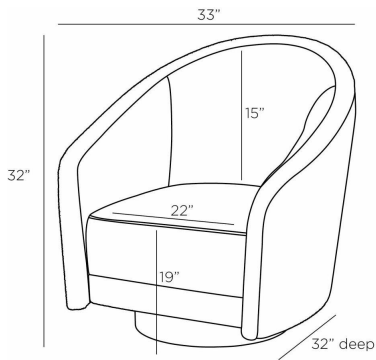

FRU05

H: 32 IN, W: 33 IN, D: 32 IN,
Cream Sherpa

This cream sherpa design is designed to cradle like a hug, providing welcoming comfort to any room. A fully upholstered barrel is wrapped with luxurious oyster leather about the sides and back for textural interest. A recessed champagne finished plinth iron base anchors the chair while concealing a 360-degree swivel mechanism. Leather will vary.

APPEARANCE

Material	Sherpa, Leather, Iron
Finish	Cream, Oyster, Champagne
Finish Will Vary	Yes
Top Coat/Sealant	No
Textile Contract Suitability	Low Traffic/Private Spaces

DIMENSIONS

Foot Print	Dia: 19.00 IN
Seat	H: 19 IN, W: 22 IN, D: 20 IN
Seat Back	H: 15 IN, W: 19 IN, D: 10.5 IN
Diagonal Dimension	45.5 IN
Clearance	3.5 IN

SHIPPING

Shipping Requirements	TruckShip
Product Weight	67.2 lbs
Gross Weight 1	92.2 lbs
Shipping Box 1	H: 32 IN, L: 33 IN, W: 32 IN

ADDITIONAL INFO

Disclaimers	This piece is made with genuine leather. The variations in color are a natural characteristic of leather and may increase over time, adding to the individuality of your item. Please keep this away from prolonged intense sunlight, heat and humidity.
Swatch Number	X72SW, T23SW
Fabric Compliancy	NFPA-260, TB117-2013
Fabric Content	94% Polyester, 6% Acrylic
Fabric Cleaning Code	S - dry clean only
Leg Or Foot Application	360 Swivel Mechanism, Nylon Glides

CONTRACT

Contract Suitable	Yes
Fabric Composition	94% Polyester, 6% Acrylic