

# Assembly Instructions

Caution: You must read this before you proceed

**Please look under The Bench Top for hardware packs**

## BENCH

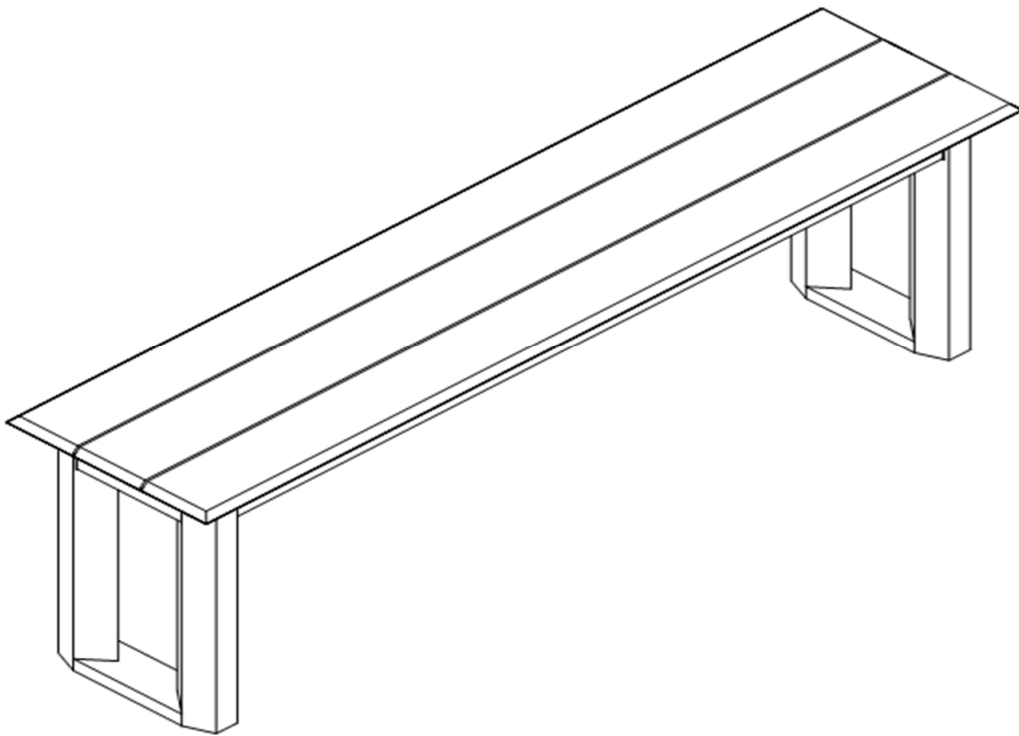





**Caution:** This Bench is NOT a TOY.



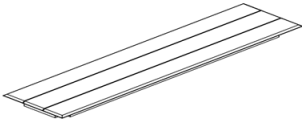

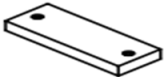
Keep your child/children at bay in the process of assembly

For turning the Bench and to prevent damage to the Bench, 02 persons may be needed to execute this action.

## Part List

Label	Picture	Description	QTY
A		Bench Top	1
B		First Leg	2
C		Support Leg	2
D		Second Leg	2

## Hardware

Label	Picture	Description	QTY
①		Bolt (M8x60mm)	9
②		Screw (M6x70mm)	5
③		Spring Washer (M8.5/10.5x2mm)	9
④		Flat Washer (M8.5/20x2mm)	9
⑤		Allen Wrench	2

# Assembly Preparation

Before Beginning Assembly:

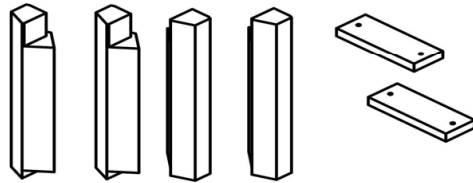
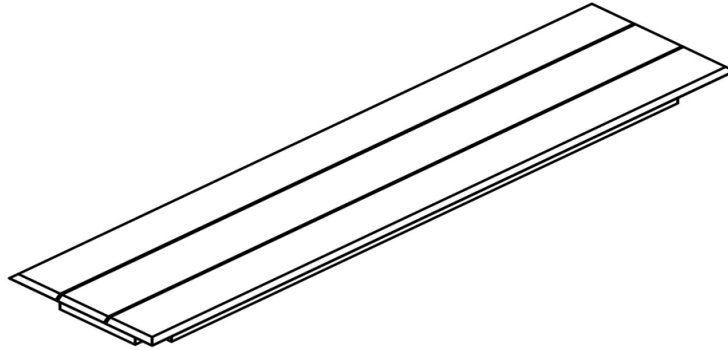

- Read instructions, cover to cover-



- Have 2 adults on hand for assembly-



- Do not assemble on flooring or carpet-



- Assemble on a clean non-marring surface (packing foam)-



- Save all packaging until finished-

# Assembly Steps

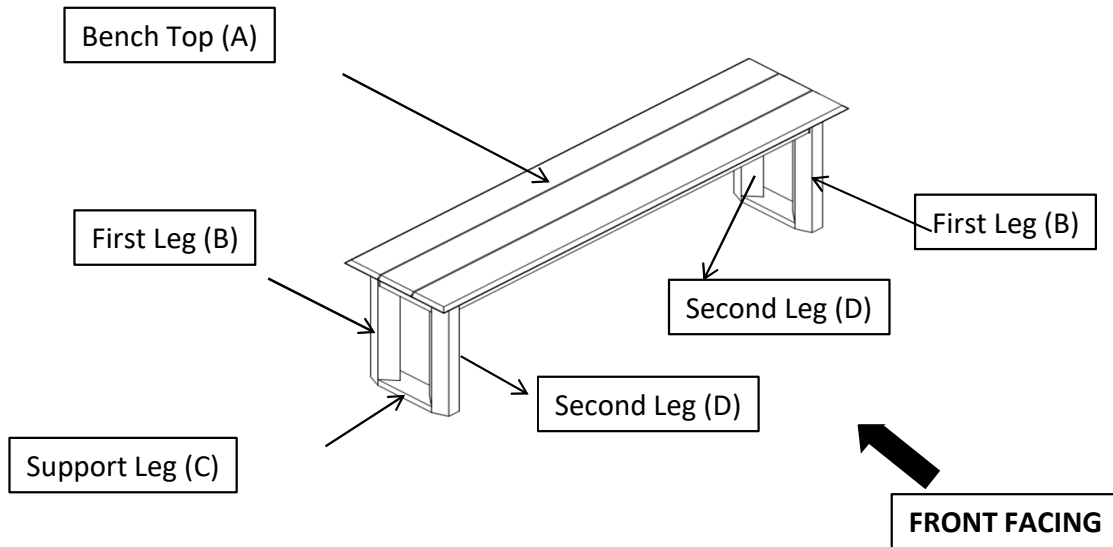

This Bench has multiple parts and may require up to 30 minutes to assemble. To give you an overview of the Bench parts, the above picture is to help you put the various parts into perspective. Please read through the instructions below to familiarise yourself with the parts and steps before assembly.

## Step 1

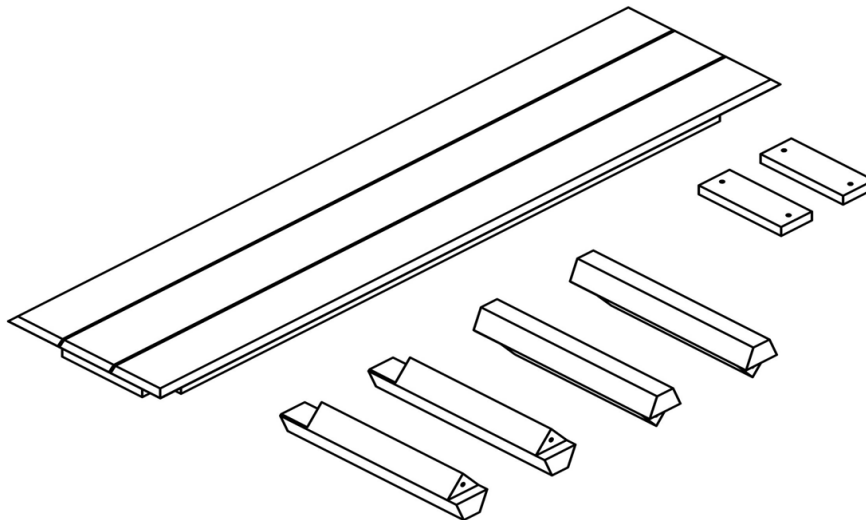

Unpack and place all parts on a clean, non-marring surface.

## Step 2

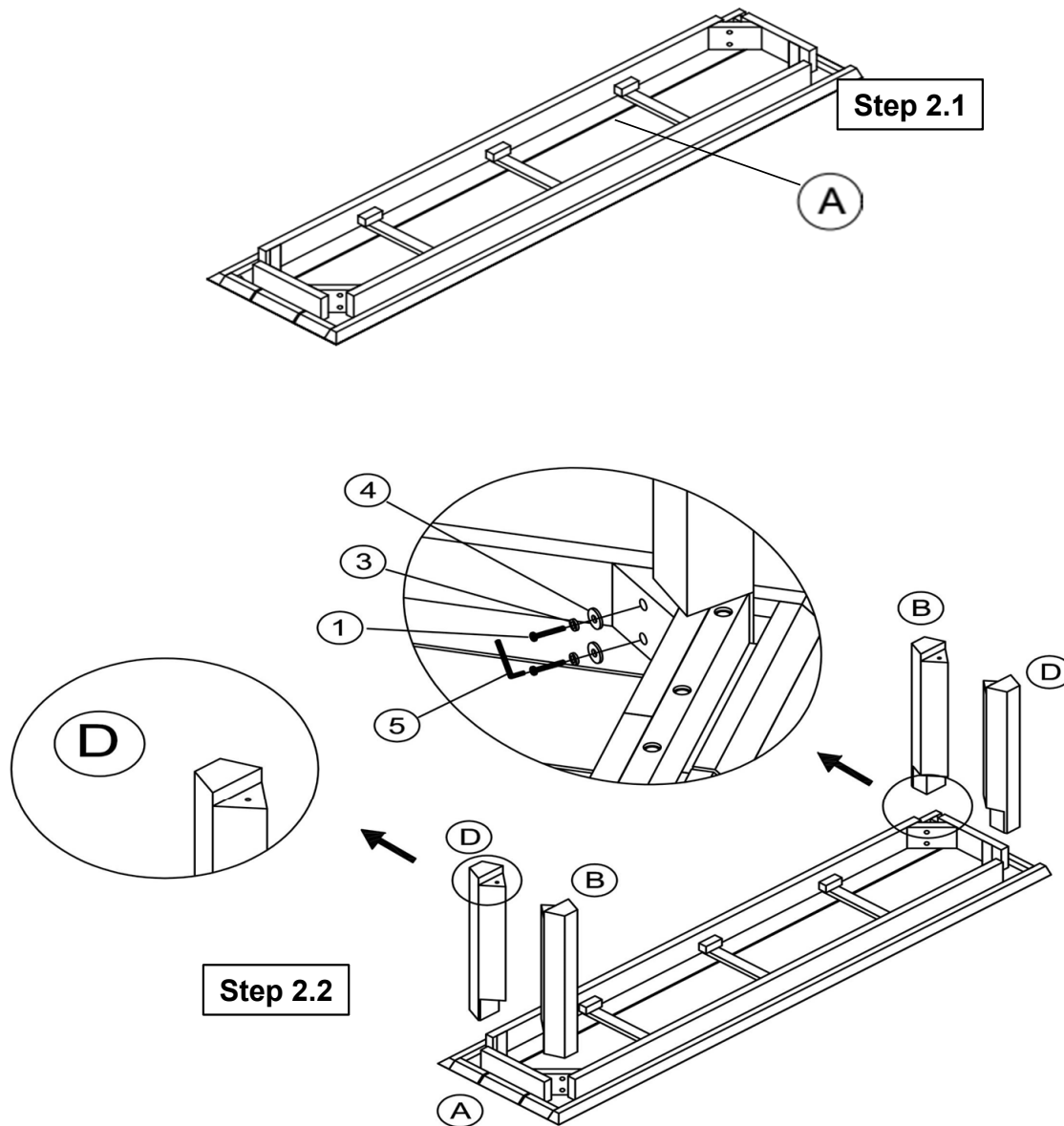

**Step 2.1)** With assistance from your adult partner, turn the Bench Top(A) up side down on a clean, non-marring surface as picture shown above.

**Step 2.2)** Attach Left First (B) to Bench Top (A) by using Bolt (①), Spring Washer (③), Flat Washer (④) and Allen Wrench (⑤) as picture shown above.

Repeat the same process with the Second Legs (D)

**Do not fully tighten Bolts.**

### Step 3

Attention: Drive Screws (2) from the bigger housing of Support Leg

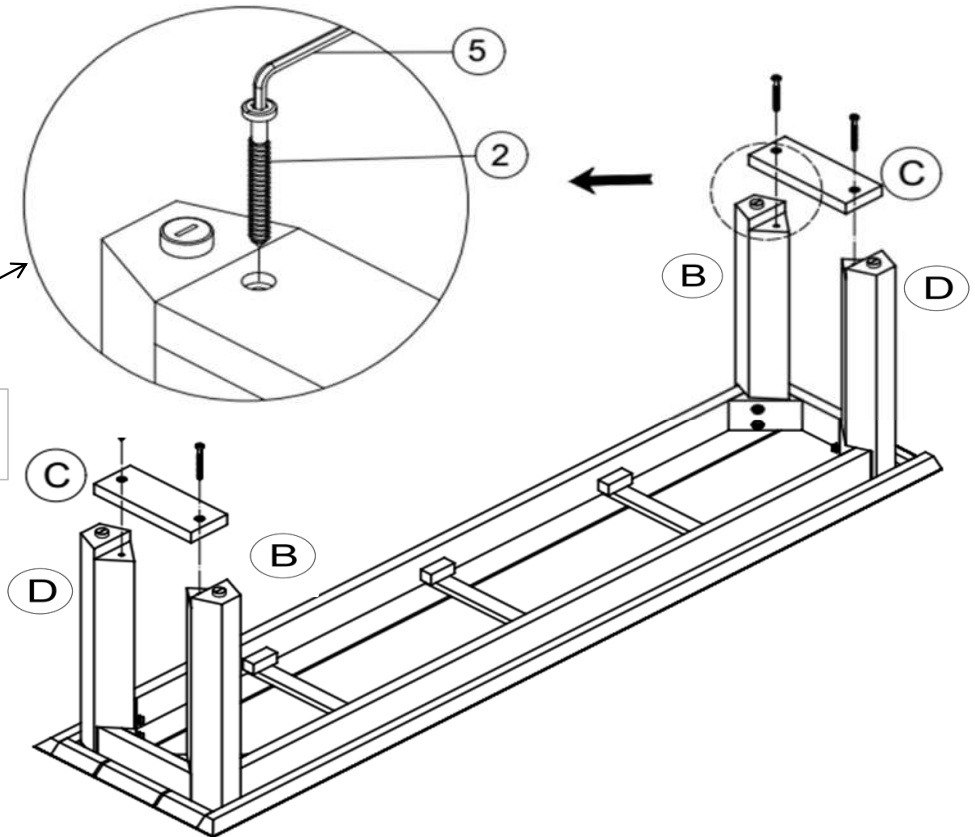

Attach Support Leg (C) to the First Leg (B) and Second Leg (D) by using Screw ((2)) and Allen Wrench ((5))  
Repeat the same process with remain Support Leg (C)  
**Do not fully tighten Screws.**

## Step 4

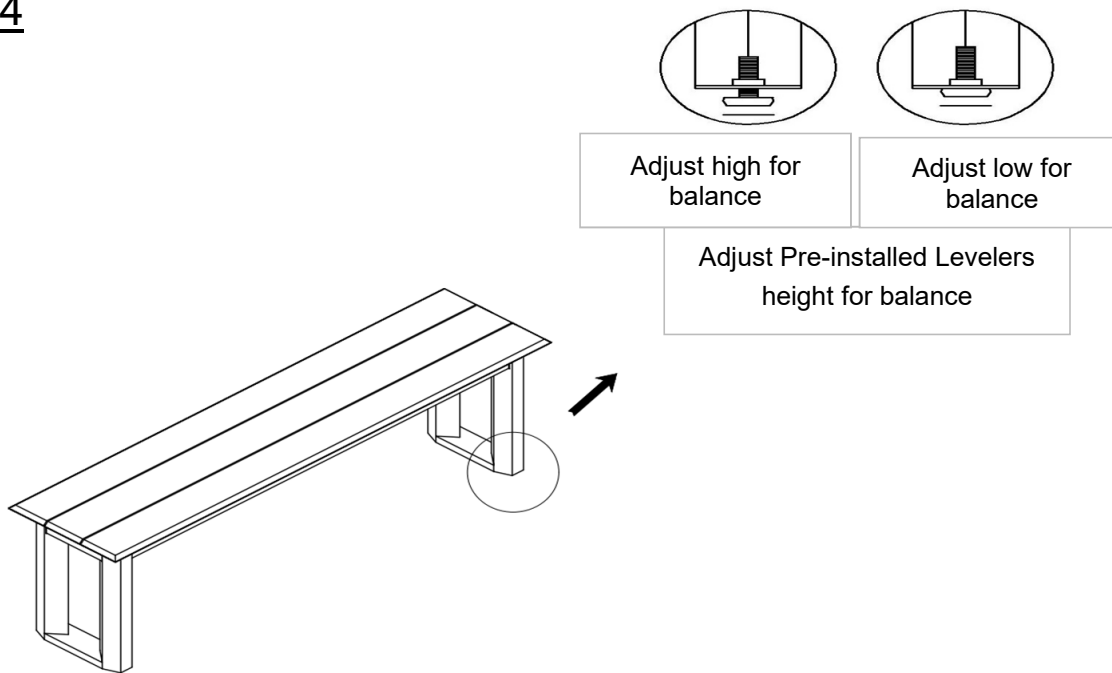

With assistance from your adult partners, turn the Bench right side up EXERT pressure, floorwards, onto the Bench.

This pressure will help the Bench reach alignment at all joints. Check for wobbles. In a sequential manner, gradually tighten all Bolts and Screws at all joints until evenly secured.

Inspect the Bench and make sure all parts are adequately connected.









Do not tighten any Bolt or Screw fully and then move on towards the next one.

With assistance from your adult partners, adjust the Levelers to desired height to avoid wobbles.

Your Bench is ready for use.

**This Bench can only be used on a flat, level surface.**

## Care & Maintenance

-  ● Do not put hot items directly on furniture surface
  -  ● Do not clean furniture with harsh cleansers or polish.
  -  ● To obtain the longest lifespan of your outdoor products, minimizing exposure to direct sunlight is recommended.
  -  ● Children should not climb or jump on the furniture.
  -  ● Do not write on furniture without a padded barrier to protect the surface.
  -  ● To obtain the longest lifespan of your outdoor products, avoid extended and lengthy exposure to rain, snow, and direct sunshine. Whenever possible cover the product and /or place under patio or awnings.
  -  ● Not for commercial use. For residential use only .
  -  ● Stains may be removed with mild soap solution and damp cloth.
- 
-  ● Dust and pick-up spills using a clean, non-colored, lint-free cloth .