

**NOTE: NO Drain Stopper Included**

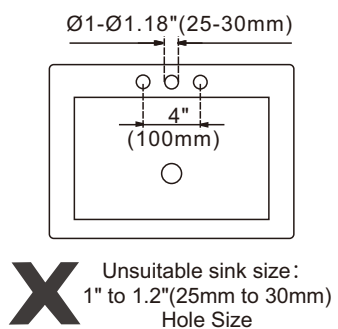

With 1.8 gpm are compliant with California water efficiency regulations, Complies with California Proposition 65 and with the Federal Safe Drinking Water Act.

In areas with extremely low water pressure causing the faucet water flow to be unsatisfactory, replace the 2.2 gpm aerator to improve the water flow in the faucet.

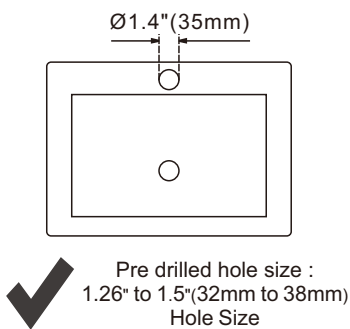
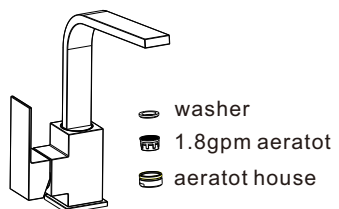

### Cleaning and Care

Care should be given to the cleaning of this product. Although its finish is extremely durable, it can be damaged by harsh abrasives or polish. To clean, simply wipe gently with a damp cloth and blot dry with a soft towel.

## Notes

Before installing the valves, clean the water pipe thoroughly to avoid dirt and deposits.

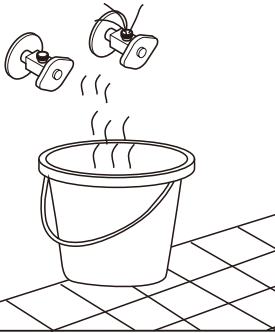

1

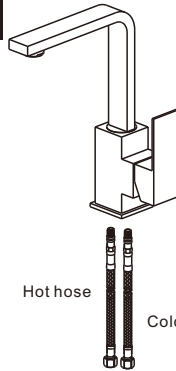

Attach flexible hoses under the faucet body.

2

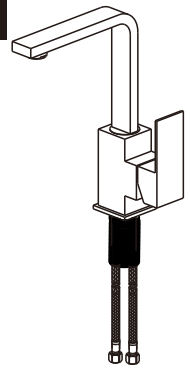

Attach mounting stud under faucet body

3

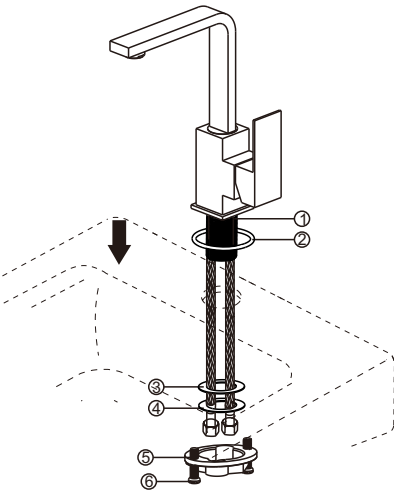

1. Make sure attach the O-ring(2) to the faucet body.
2. Slide tubes down through mounting hole on sink.  
Option: If sink is uneven, use silicone under the faucet body.
3. Place washer(3) and metal plate(4) over mounting stud under sink.
4. Screw hexagonal lock nut (5) on to threaded rod (1) and tighten.
5. Screw the nut (5) with screws (6) to fix the faucet body

4

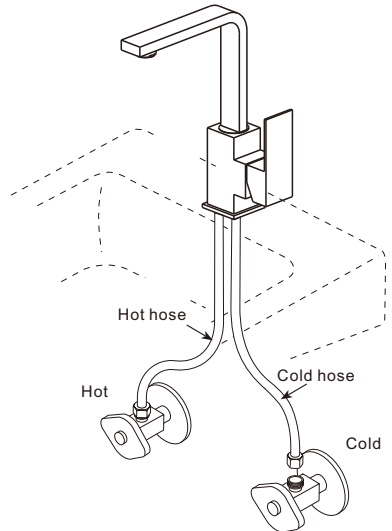

Secure metal nut on faucet supply hoses to supply valve connection and hand tighten, then tighten one additional revolution with wrench. **DO NOT OVERTIGHTEN.** **WARNING:** Do not use pipe dope or other sealants on water connections.