

STEP 4

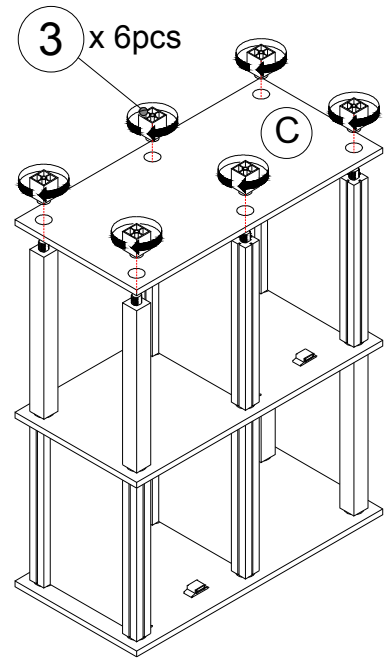

STEP 5

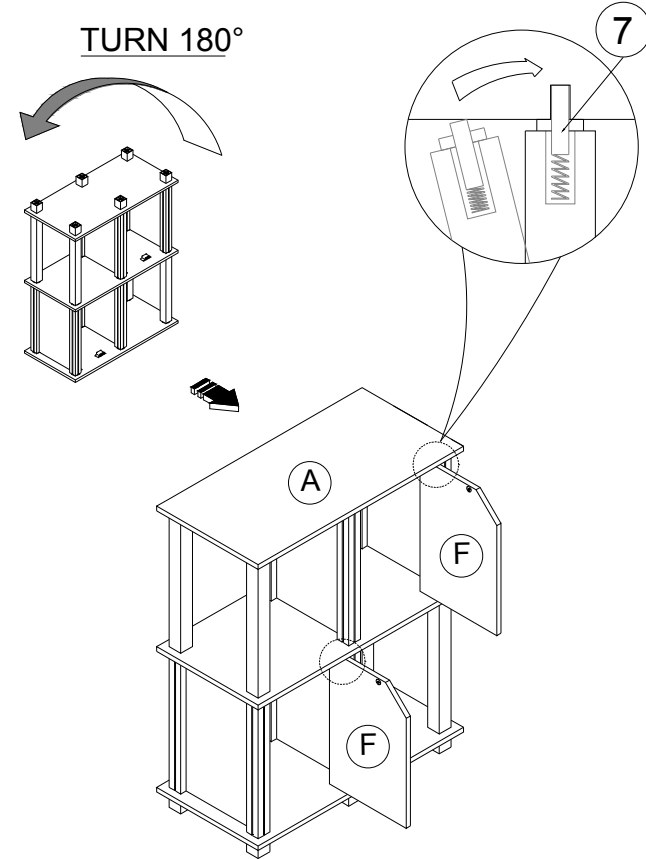

Recommended Maximum Weight

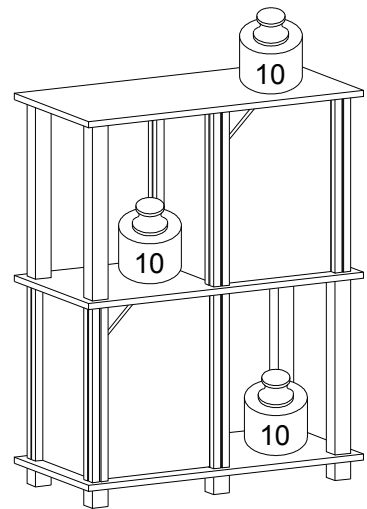

*Unit in Pound(lbs.)

WARNING:

>This unit has been designed to support the maximum loads shown. Exceeding these load limits could cause sagging, instability, product collapse, and/or serious injury.

>DO NOT allow children to climb on unit.

> Put heavier items on lower shelves.

00:15

Approx. 15 minutes



Recomm. 1 Person

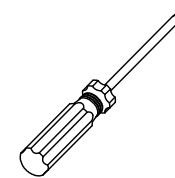





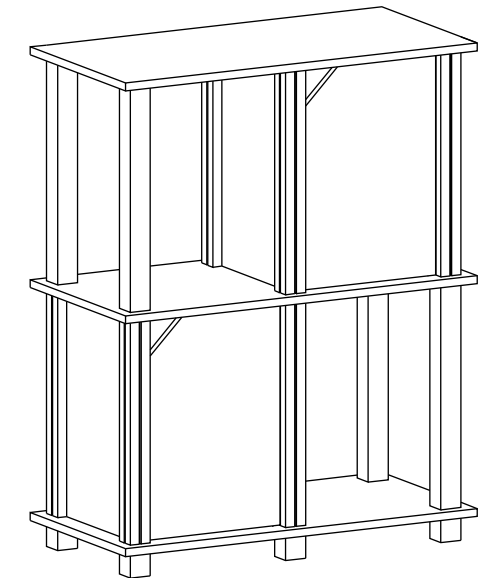

Tools Required

Assembly Instruction

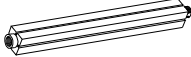
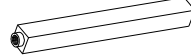
3-Tier Storage Shelf With 2 Doors



HARDWARE & PARTS LIST

NO	HARDWARE LIST	QTY
1	SQ LONG POLE WITH GROOVE 	8pcs
2	SQ LONG POLE 	4pcs
3	SQ LEG 	6pcs
4	ROUND RING 	6pcs
5	MAGNET 	2pcs
6	FLAT SCREW 	2pcs
7	DOOR SPRING SUPPORT 	4pcs

NO	PARTS LIST	QTY
A	TOP PANEL	1pc
B	CENTER PANEL	1pc
C	BOTTOM PANEL	1pc
D	SIDE PANEL	4pcs
E	BACK PANEL	2pcs
F	DOOR PANEL	2pcs

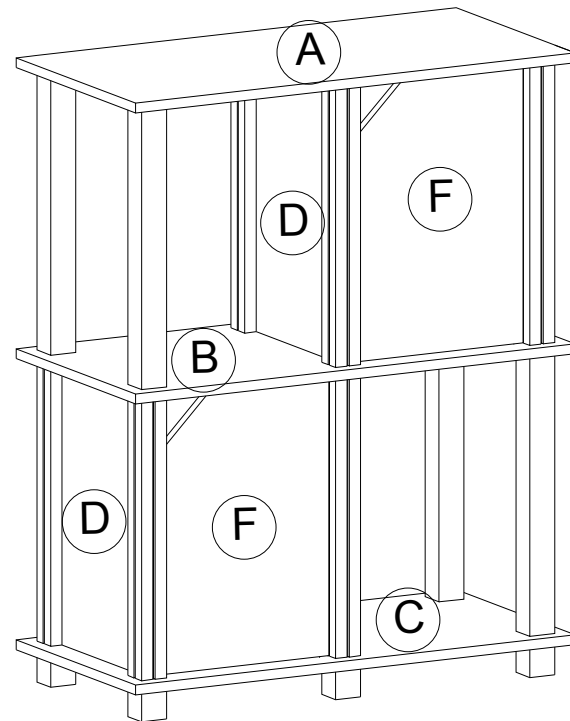

USEFUL HINTS BEFORE YOU START:

1. Read each step carefully before starting.
2. It is important that each step is performed in correct order to avoid difficulties.
3. Identify, sort and count the parts before assembly.
4. Assemble your furniture on packaging cardboard to prevent scratch or damage.
5. Clean the product with mild cleanser using soft damped cloth. Do not use harsh or abrasive cleanser.
6. Using incompatible hardware might cause damage to product.

ASSEMBLY INSTRUCTIONS

BEFORE YOU BEGIN, PLEASE READ ASSEMBLY INSTRUCTION CAREFULLY, FOLLOW THEM STEP BY STEP.

STEP 1

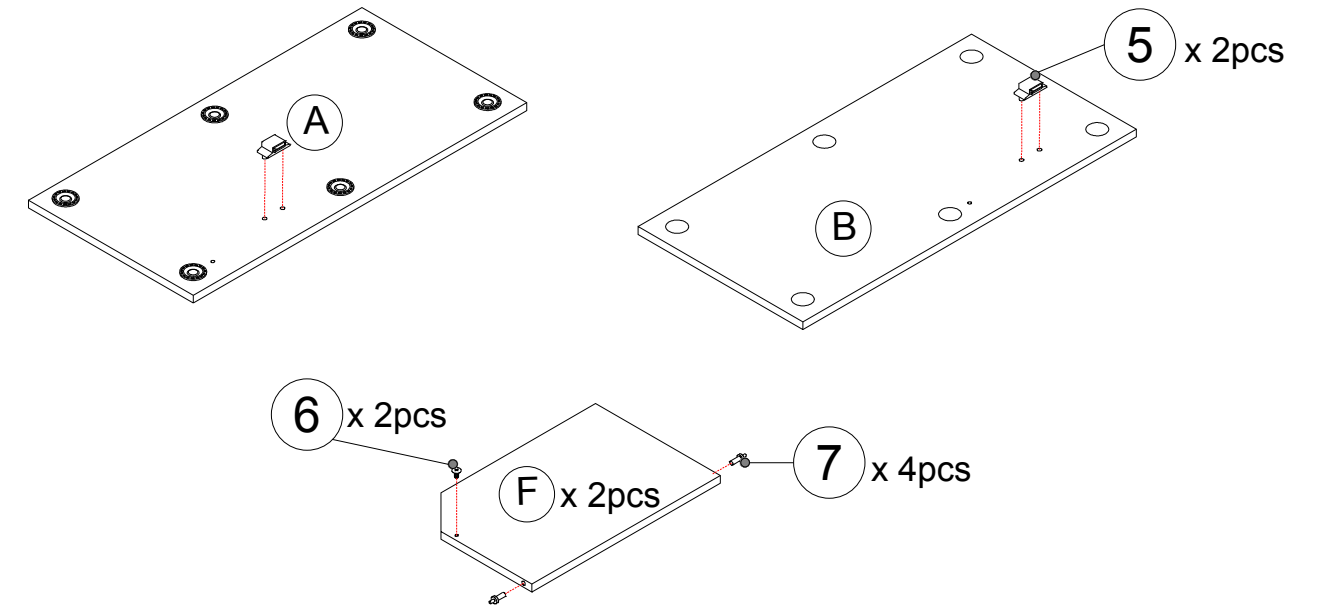

STEP 2

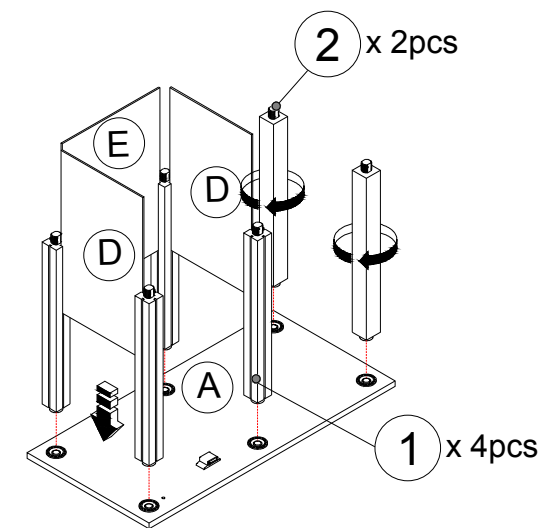

STEP 3

