

ASSEMBLY INSTRUCTIONS



VANITY SET

ASSEMBLY INSTRUCTIONS

ASSEMBLY TIPS:

1. Remove hardware from box and sort by size.
2. Please check to see that all hardware and parts are present prior to start of assembly.
3. Please follow attached instructions in the same sequence as numbered to assure fast & easy assembly.



WARNING!











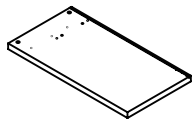

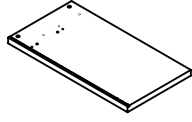

1. Don't attempt to repair or modify parts that are broken or defective. Please contact the store immediately.
2. This product is for home use only and not intended for commercial establishments.

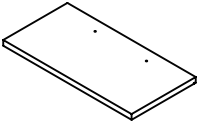

ASSEMBLY TIME

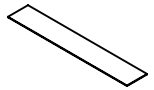
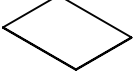
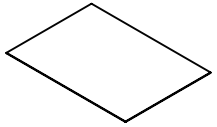
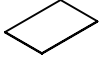
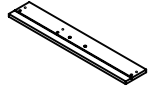



90 MINUTES



PARTS IDENTIFICATION

A	LOWER LEFT SIDE PANEL		1PC	J	LEFT DRAWER SIDE PANEL		1PC
B	LOWER RIGHT SIDE PANEL		1PC	K	RIGHT DRAWER SIDE PANEL		1PC
C	LOWER CROSS PANEL		1PC	L	LONG PARTITION PANEL		1PC
D	LOWER BACK BOARD		1PC	M	SHORT PARTITION PANEL		2PCS
E	LOWER TOP PANEL		1PC	N	DRAWER DIVIDER PANEL		1PC
F	LARGE BACK PANEL		1PC	O	LEFT DRAWER BOTTOM PANEL		1PC
G	SMALL BACK PANEL		1PC	P	RIGHT DRAWER BOTTOM PANEL		1PC
H	DRAWER FRONT PANEL		1PC	Q	UPPER LEFT SIDE PANEL		1PC
I	DRAWER BACK PANEL		1PC	R	UPPER RIGHT SIDE PANEL		1PC

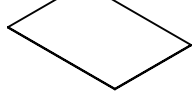



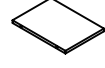

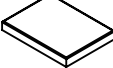

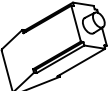
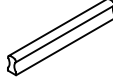
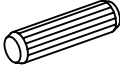

NOTE:

Phillips head screw driver is required in the assembly process; however, manufacturer does not provide this item.

S	UPPER BOTTOM PANEL		1PC
T	UPPER CROSS PANEL		2PCS
U	UPPER TOP PANEL		1PC
V	UPPER BACK PANEL		1PC
W	MIRROR		1PC

X	SEAT SIDE PANEL		2PCS
Y	SEAT BOTTOM PANEL		1PC
AA	SEAT FRONT DIVIDER PANEL		1PC
AB	SEAT BACK DIVIDER PANEL		1PC
AC	SEAT CUSHION		1PC

HARDWARE IDENTIFICATION

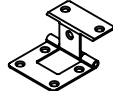







NO	DESCRIPTION	FIGURE	Q'TY	NO	DESCRIPTION	FIGURE	Q'TY
1	GLUE 40g		1 PC	8	HANDLE L = 120mm		1PC
2	WOODEN DOWEL Ø 8x30mm		35PCS	9	HANDLE BOLT Ø 4x23mm		2PCS
3	CAM BOLT Ø 7x35.5mm		29PCS	10	EURO SLIDE L = 350mm		1SET
4	CAM LOCK Ø 15x12mm		29PCS	11	SCREW FOR EURO SLIDE Ø 3x12mm		12PCS
5	LONG SCREW Ø 4.3x35mm		6PCS	12	DUAL EXTENSION SLIDE L = 375mm		1SET
6	PLASTIC FEET Ø 15mm		8PCS	13	SCREW FOR DUAL EXTENSION SLIDE Ø 3.5x12mm		12PCS
7	HOOK		10PCS	14	HINGE		2PCS

NOTE:

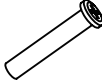
Phillips head screw driver is required in the assembly process; however, manufacturer does not provide this item.

Z

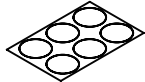
HARDWARE IDENTIFICATION

NO	DESCRIPTION	FIGURE	Q'TY	NO	DESCRIPTION	FIGURE	Q'TY
15	HINGE SCREW Ø 4x15mm		14PCS	20	FIXER		8PCS
16	PIPE THREAD Ø 6.2x47mm		2PCS	21	FIXER SCREW Ø 3x19mm		8PCS
17	LARGE BOLT Ø 4.5x22mm		2PCS	22	RING BOX		1PC
18	METAL PLATE 4.5x12.3x1.2mm		2PCS	23	STICKER Ø 20mm		5PCS
19	METAL PLATE SCREW Ø 3x15mm		4PCS				

Z8,Z9,Z10,Z12,Z13,Z14,Z22 not included in blister packaging.

STEP 1

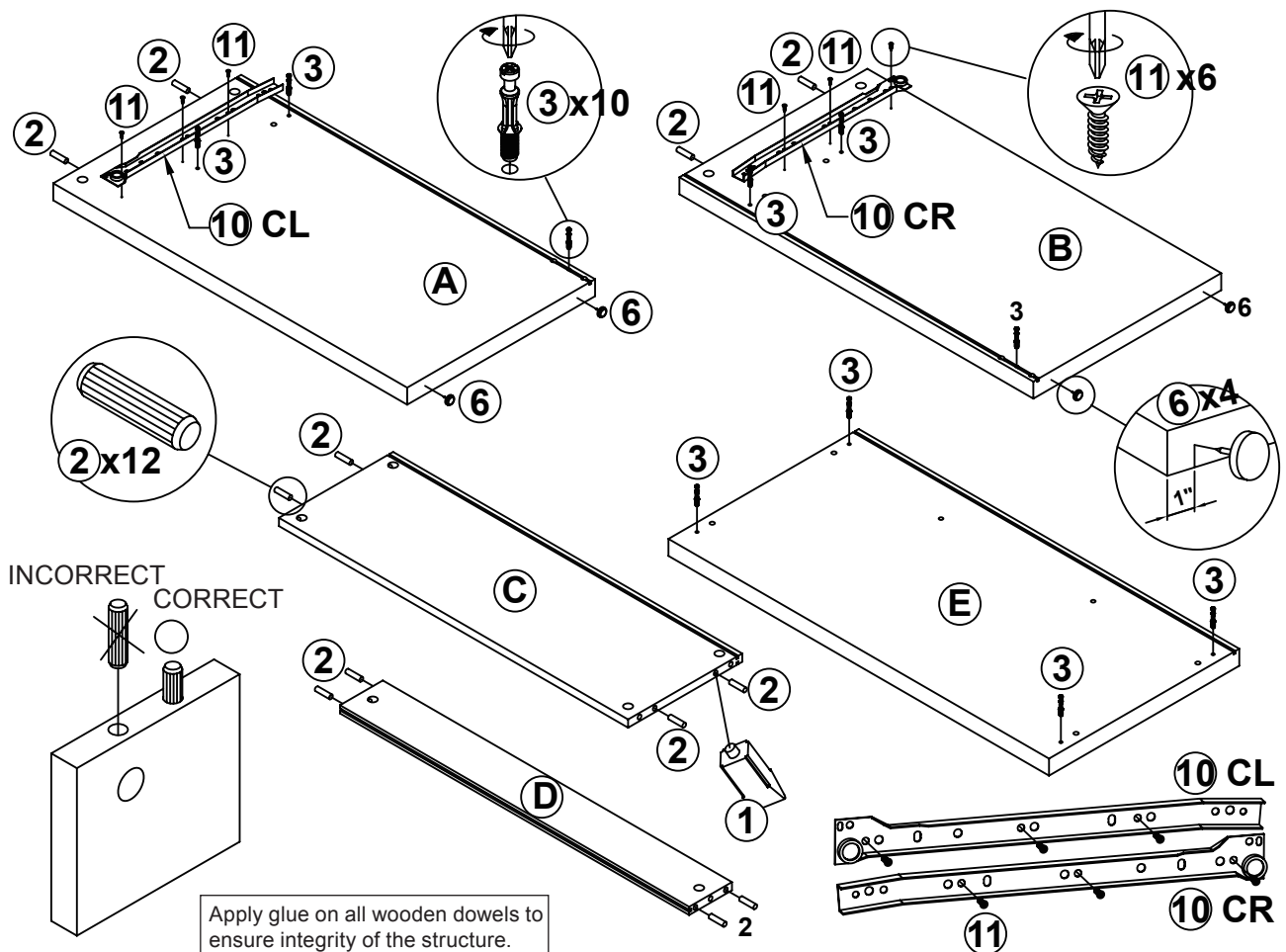

STEP 2

Apply glue on all wooden dowels to ensure integrity of the structure.

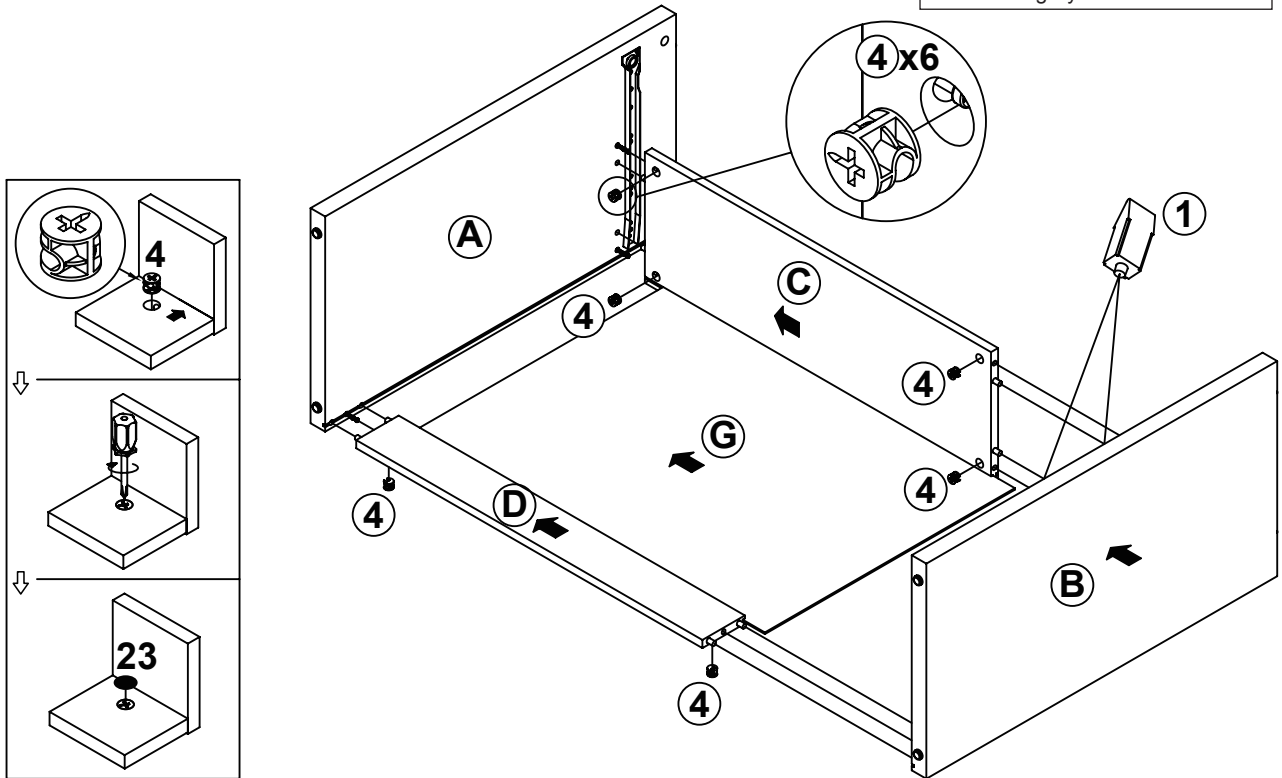

STEP 3

Apply glue on all wooden dowels to ensure integrity of the structure.

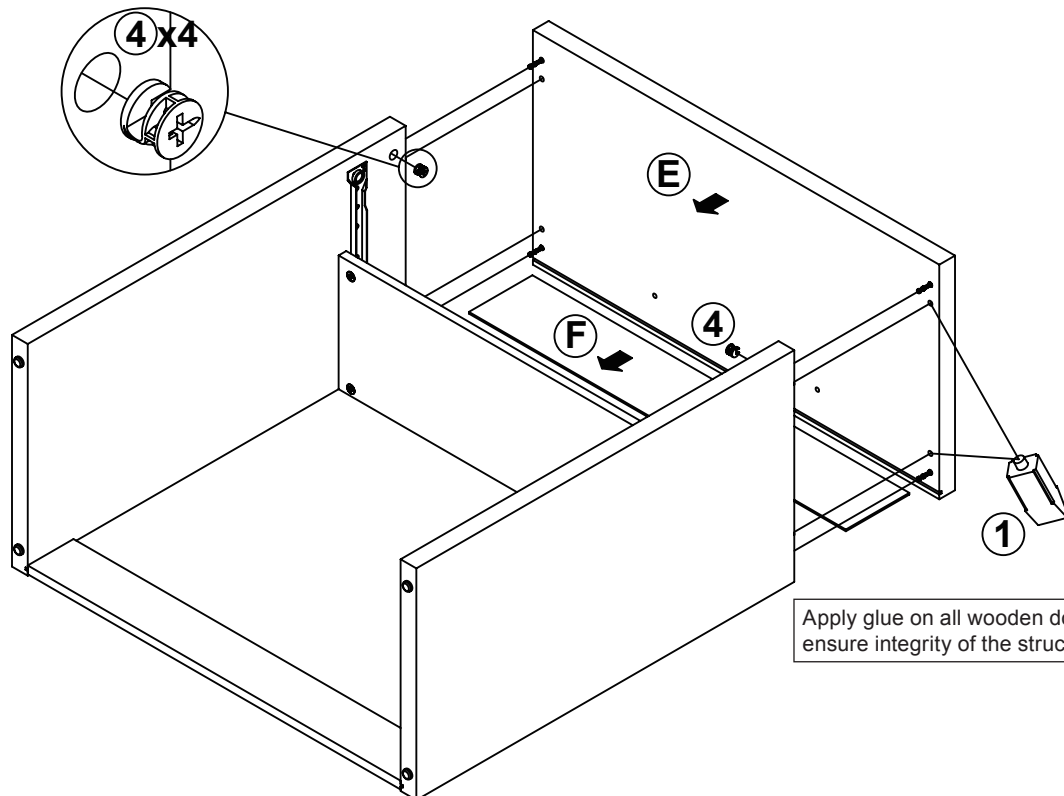

STEP 4

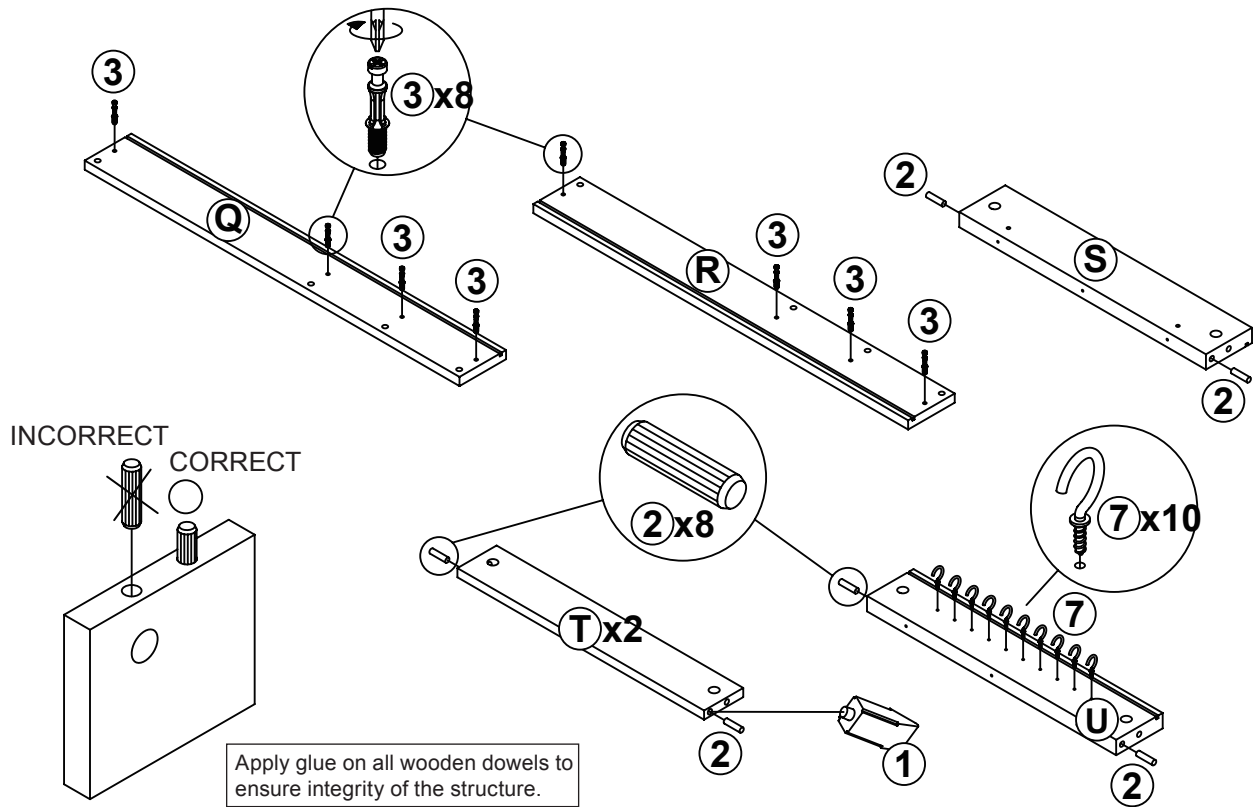

STEP 5

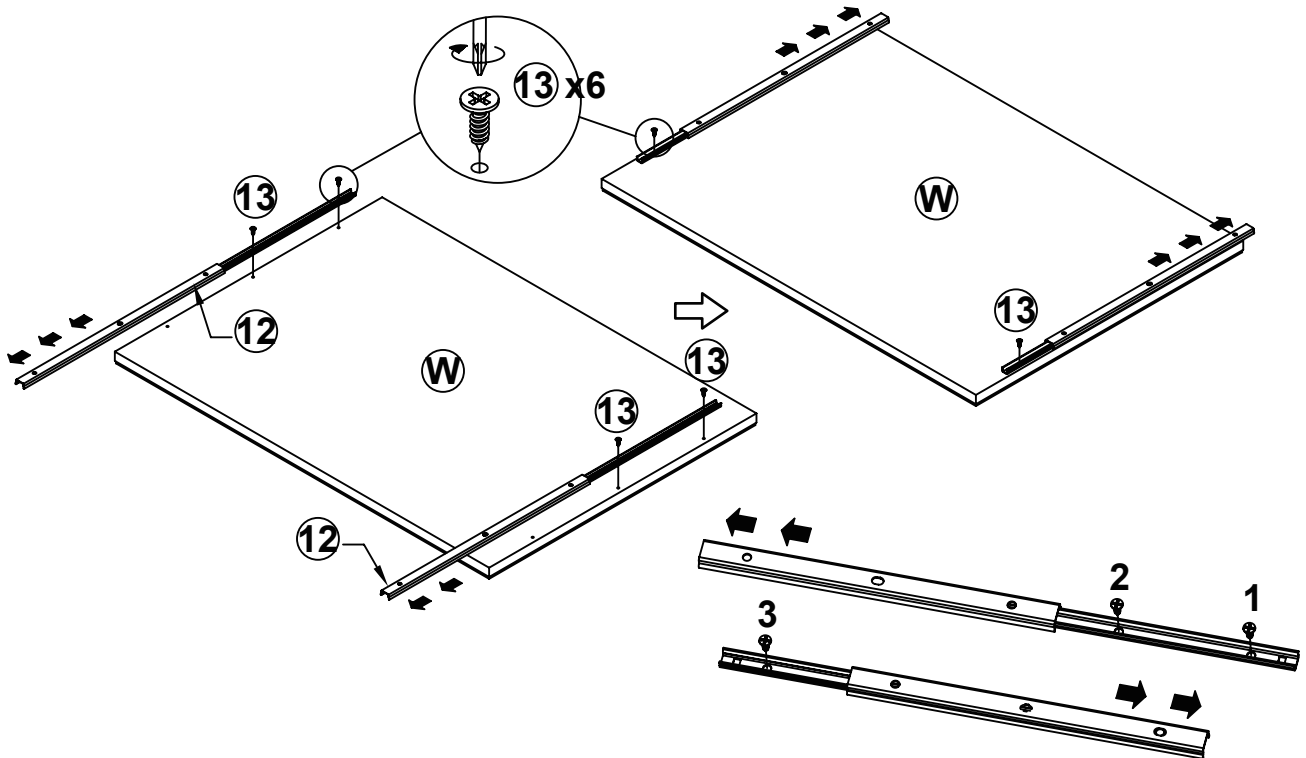

STEP 8

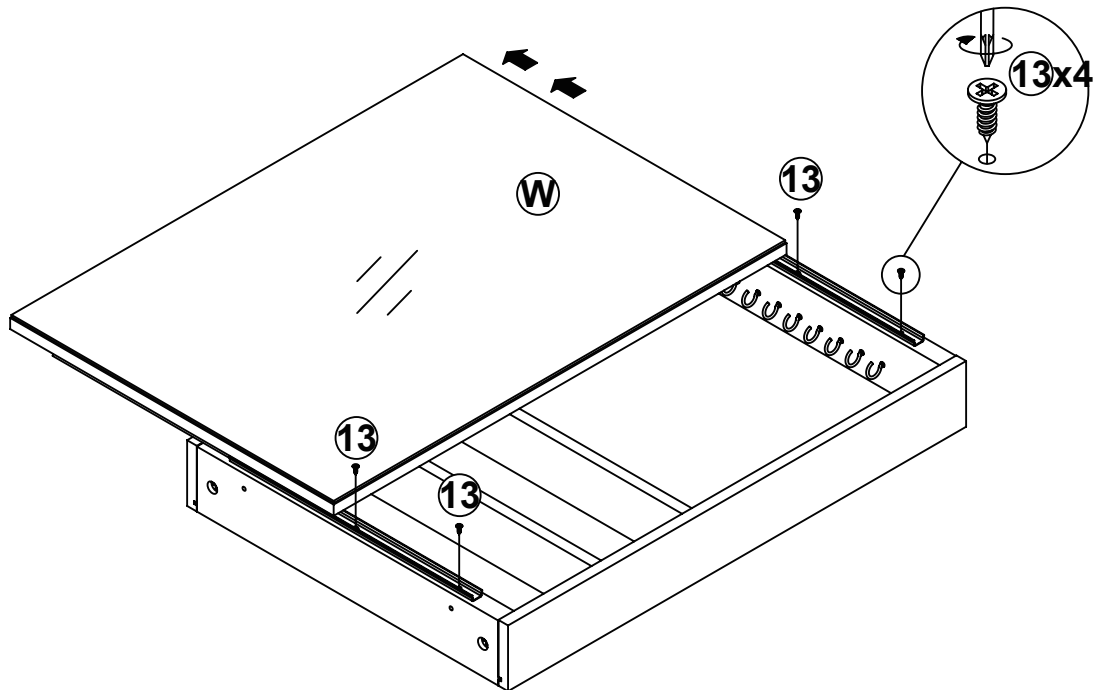

STEP 9

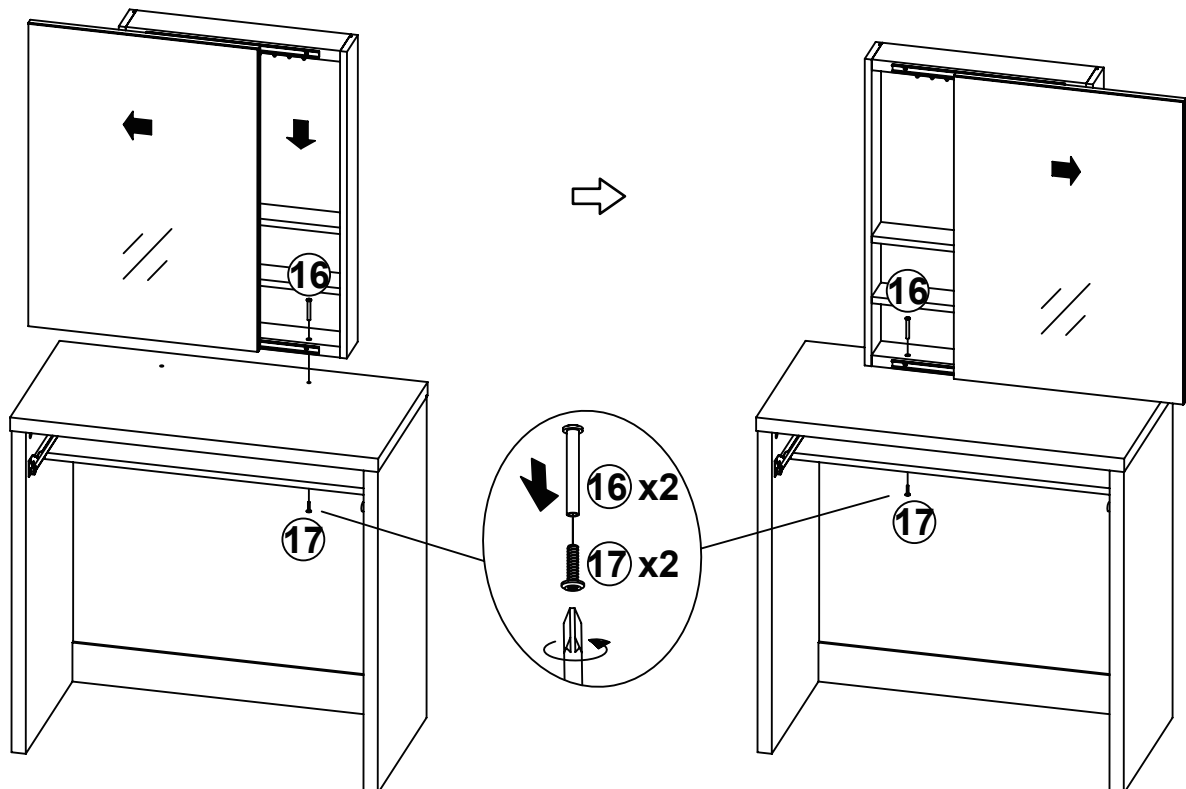

STEP 10

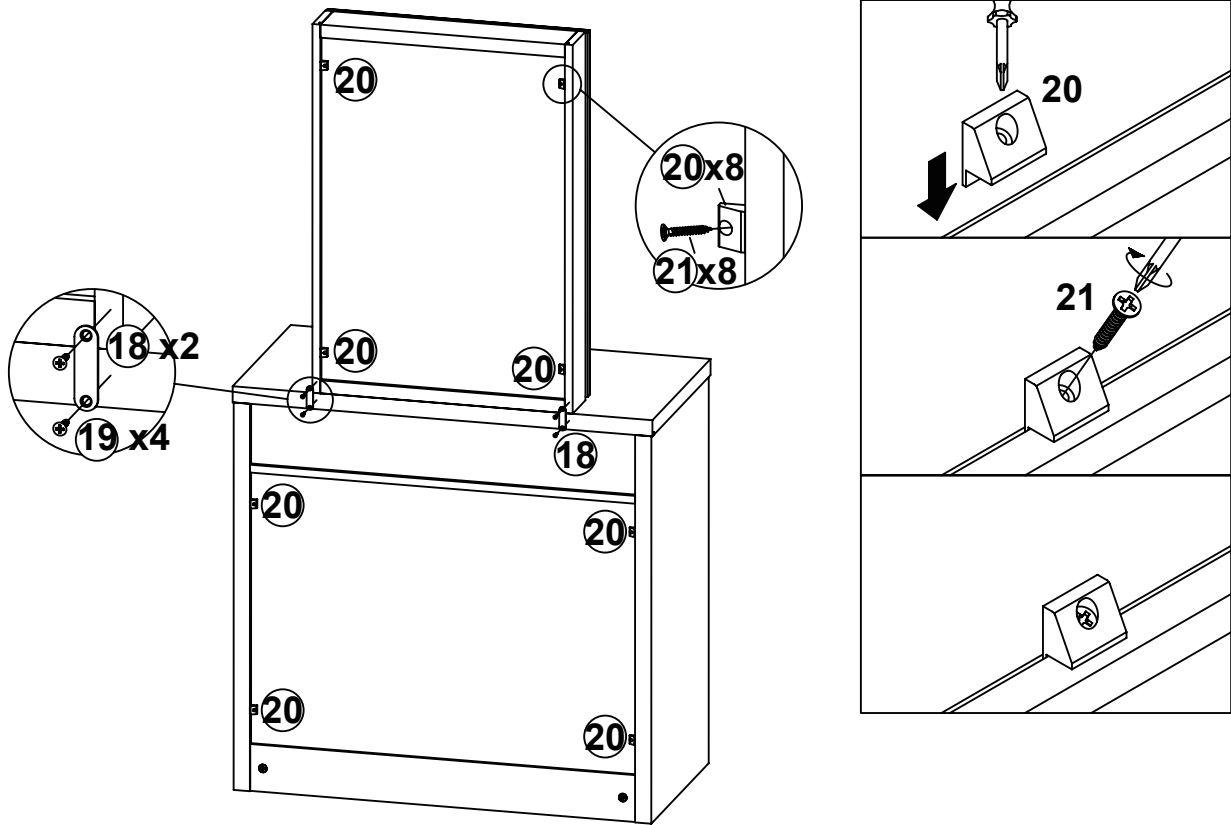

STEP 11

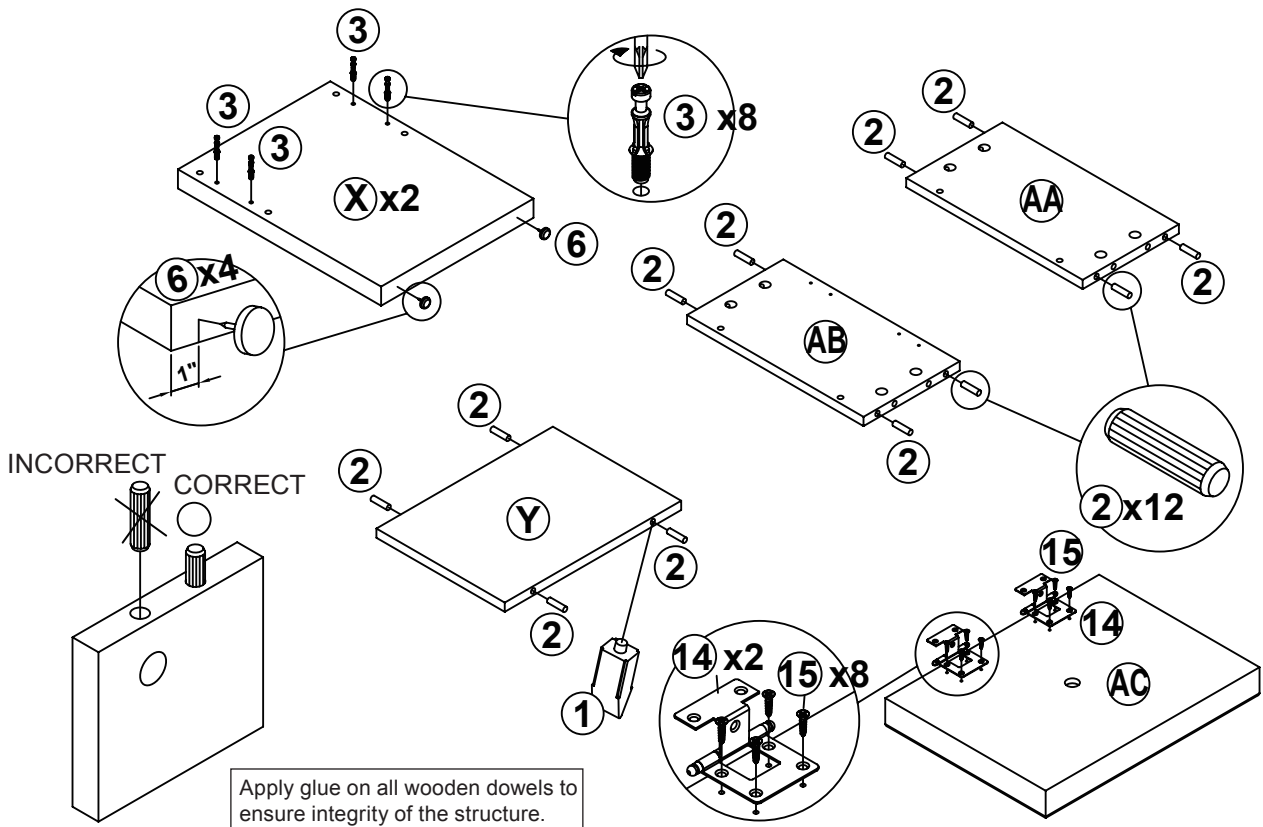

STEP 12

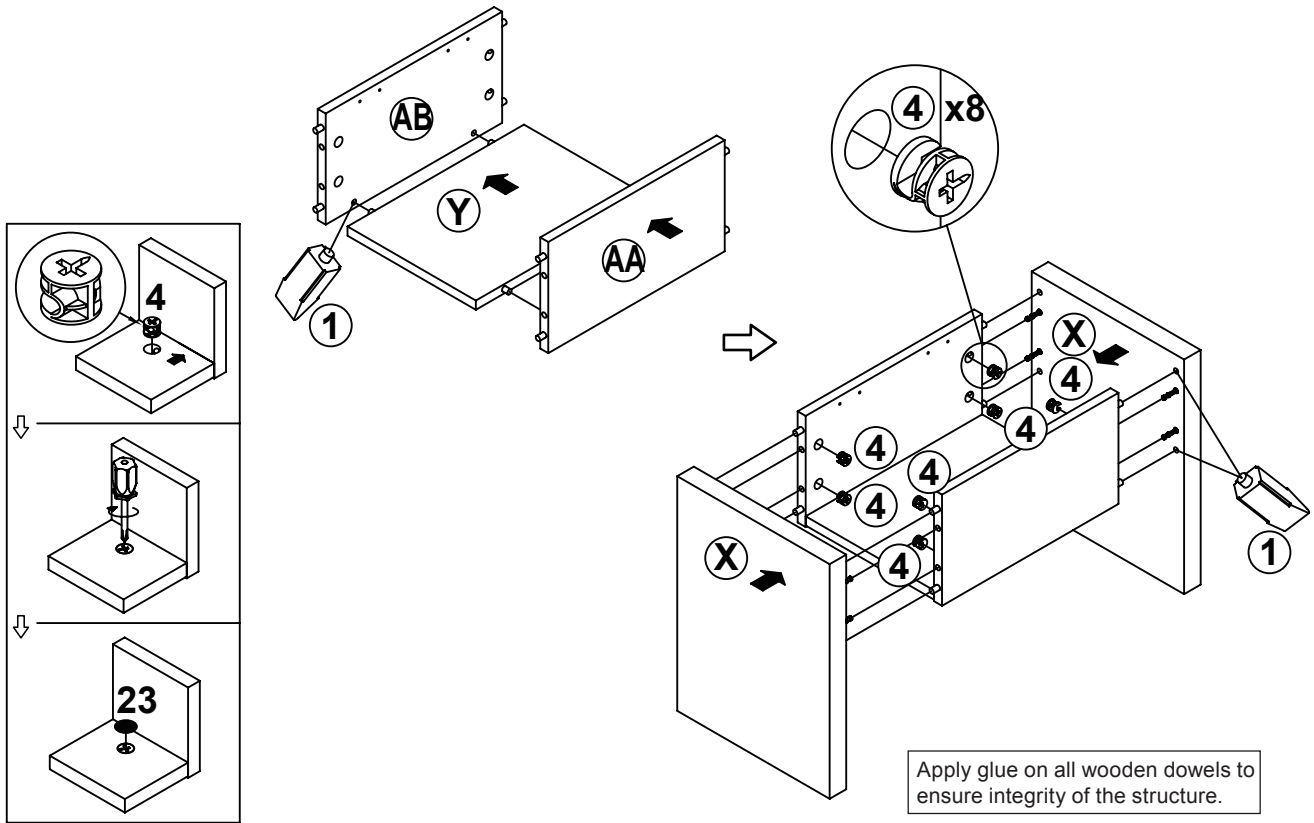

STEP 13

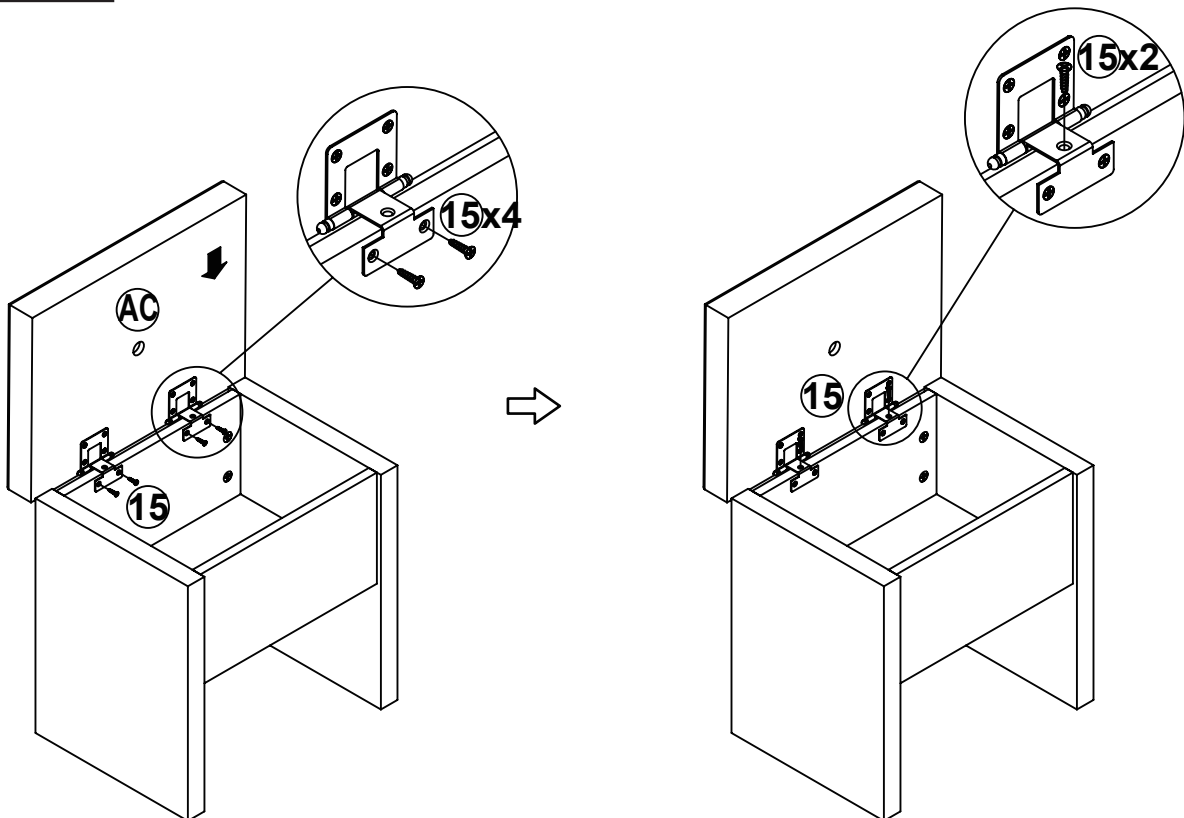

STEP 14

Apply glue on all wooden dowels to ensure integrity of the structure.

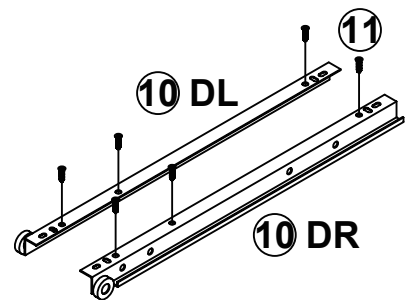
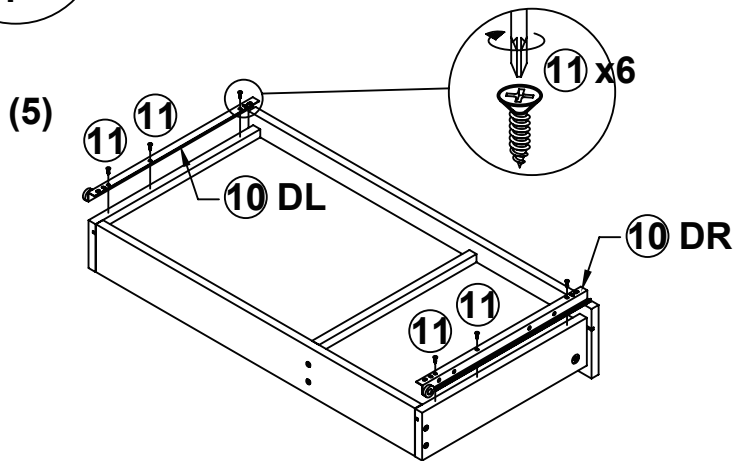
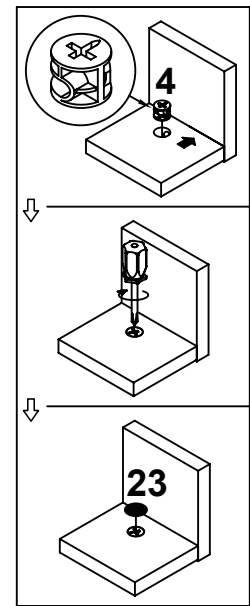
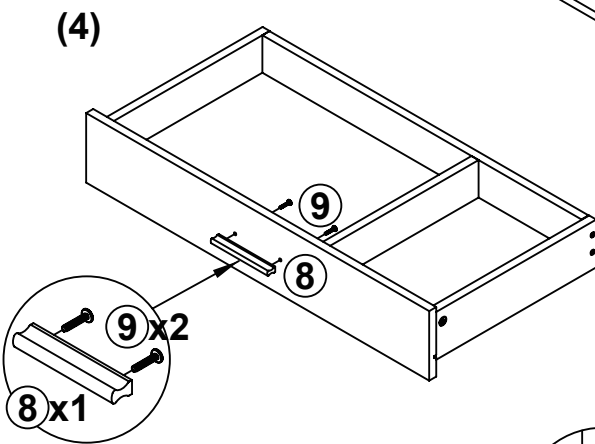
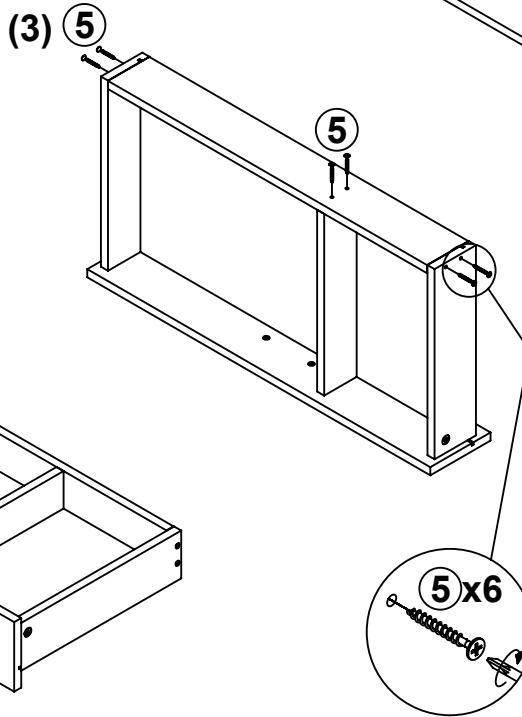
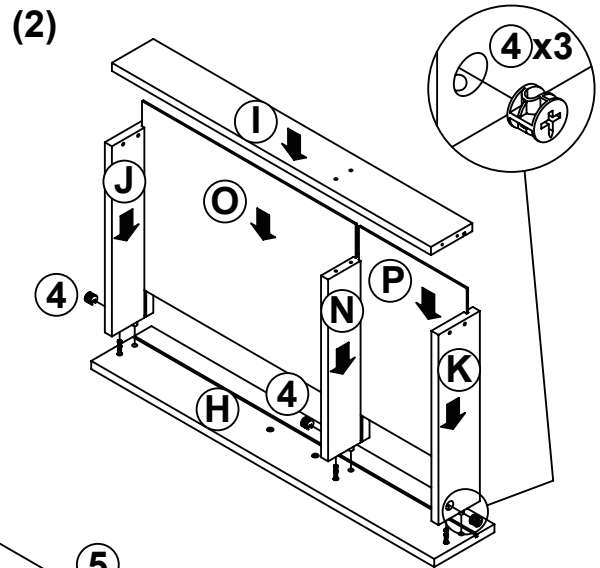
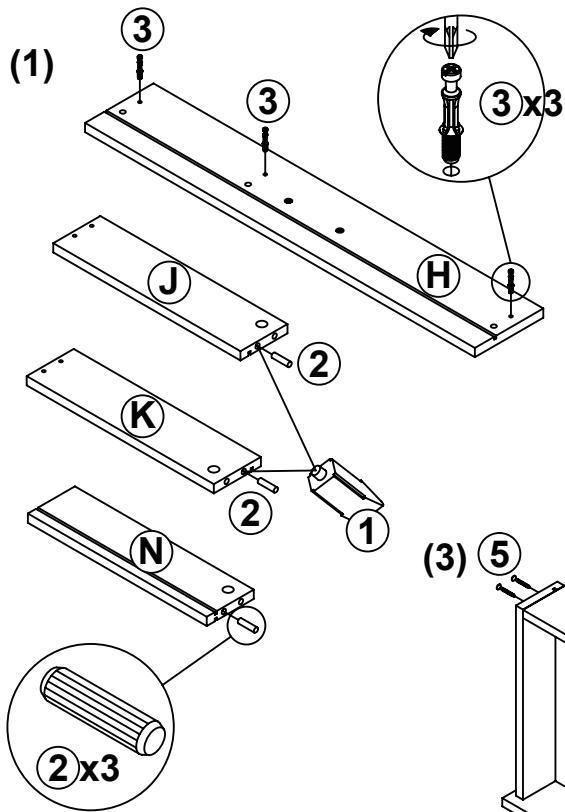

STEP 15

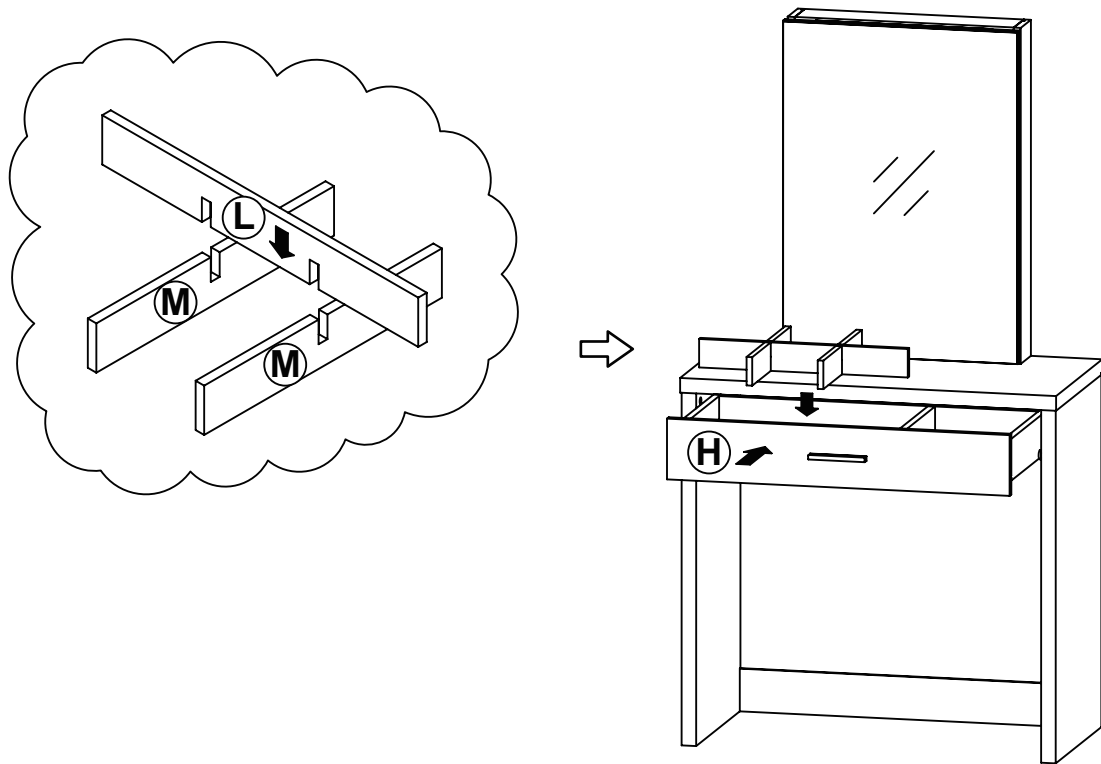

STEP 16

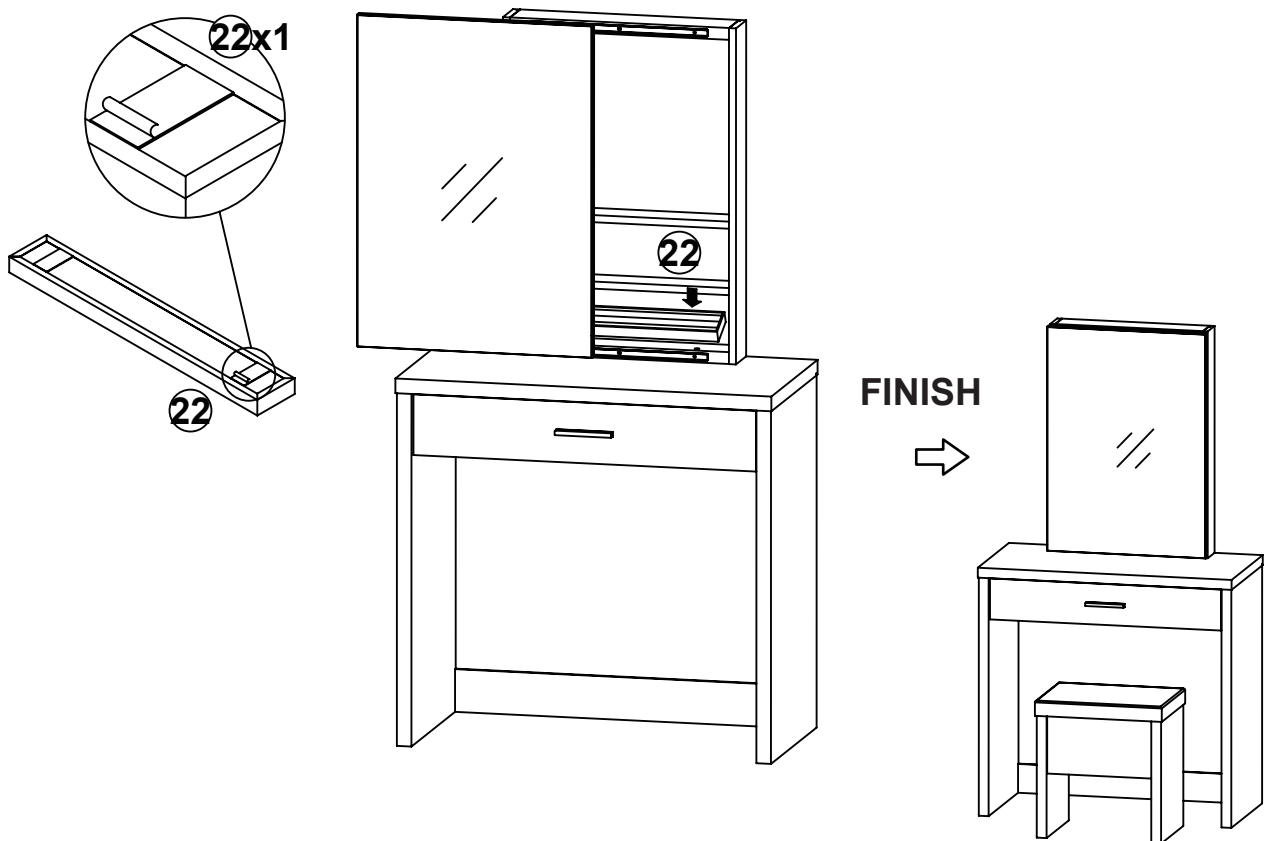

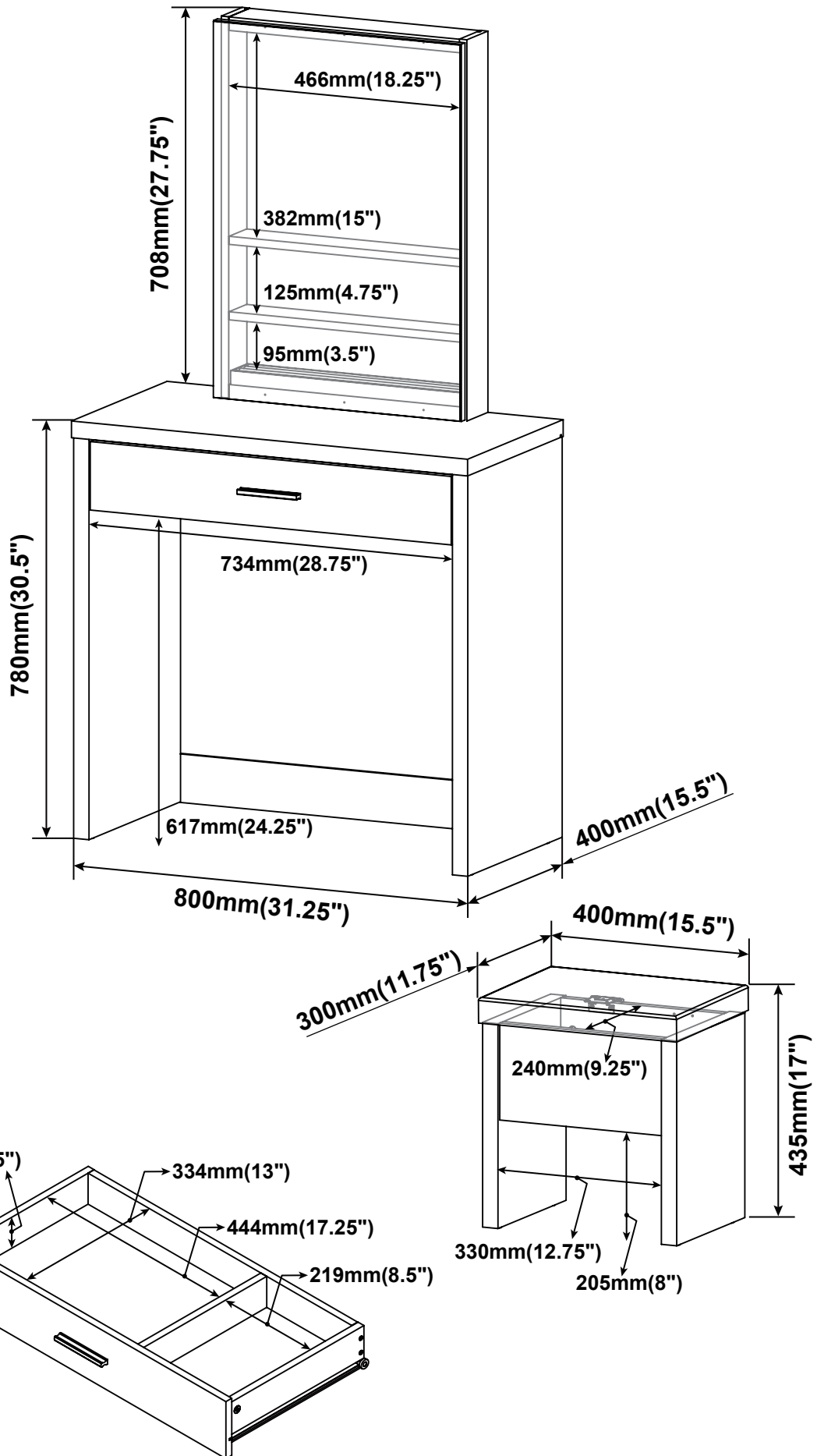

Note : Dimension tolerance $\pm 5\%$