

Assembly Manual

OFFICE CHAIR

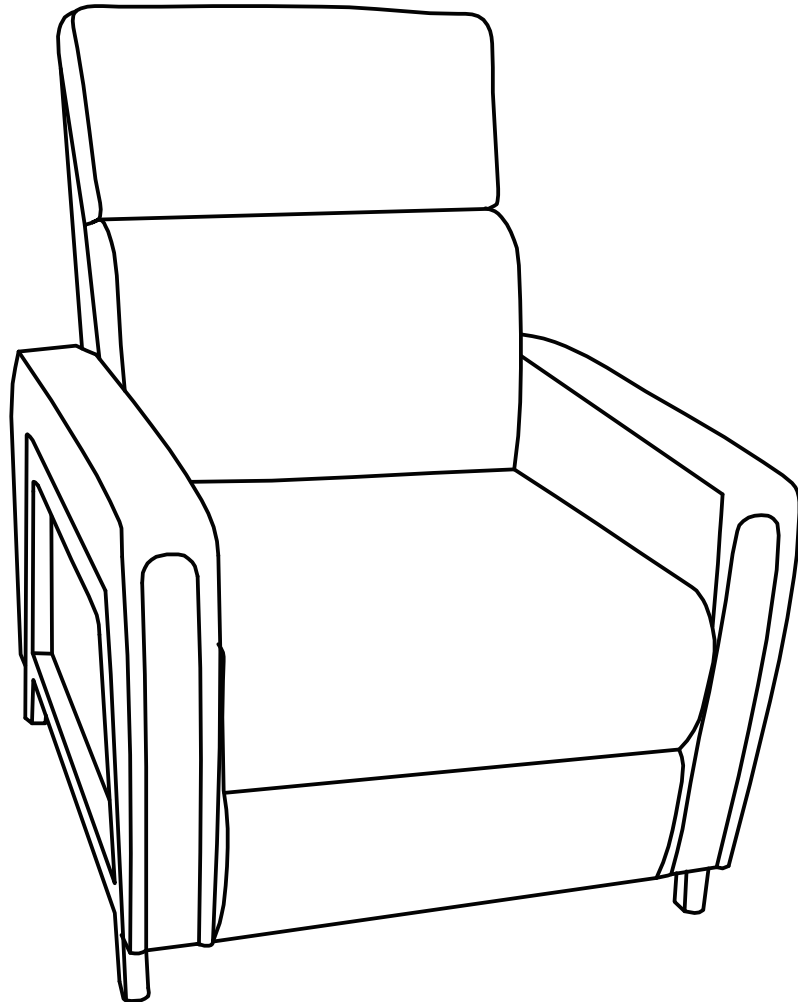

Matters Needed Attention for Chair

Thank you for the recent purchase of our product. We hope you will be pleased with both the product and service you received. If not, please give our helpful customer service team an opportunity to improve your experience right away.







Installation Troubleshoot

- The parts are missing/damaged in transportation, contact us to get replacement part.
- The screws can not insert or the slots for the screw is stripped, contact us to get help.

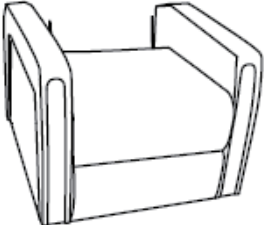
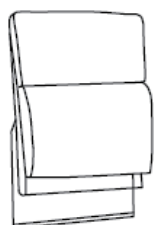
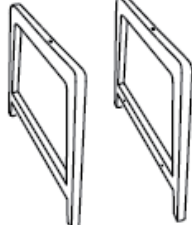
If you are not 100% satisfied with the chair, please give us a chance to help you solve all your problems with our products.

And we also need your suggestions to improve the quality of the chairs to avoid the same problems happening again, this is the most important thing we can do as a new brand.

Accessories List

<p>A Seat x1</p> 	<p>B Backrest x1</p> 	<p>C Seat Frame x2</p> 	<p>D Screws (M6x75mmx4)</p> 
<p>E Screws (M6x40mmx2)</p> 	<p>F Spacer (Ø28 mmx4)</p> 	<p>G Spacer (Ø28 mmx2)</p> 	<p>H Hexagon Wrench (L-Shape)</p> 

Assembly Instruction

STEP 1

Attach the seat frame to both sides of the seat and secure it with two M6 × 40 mm bolts, using two Ø28 mm spacers for spacing.

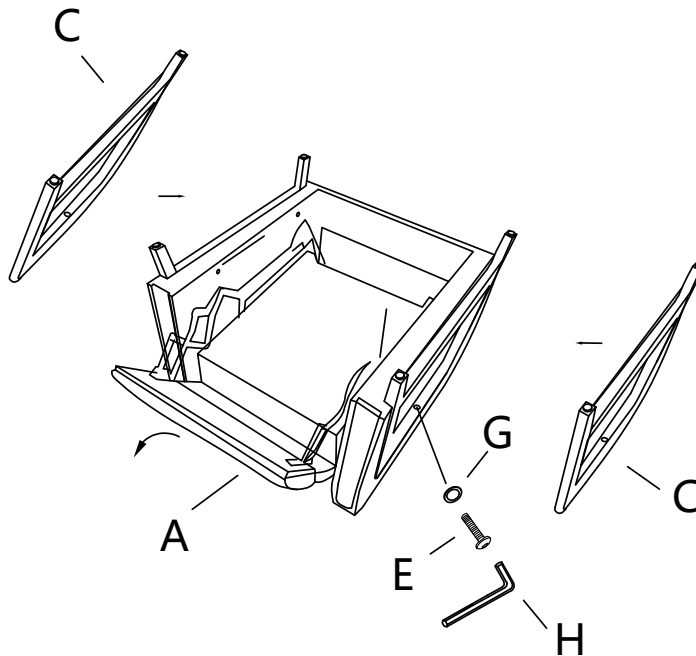

STEP 2

Next, secure it with four D screws (M6 × 75 mm), using four F spacers (Ø28 mm) for spacing.

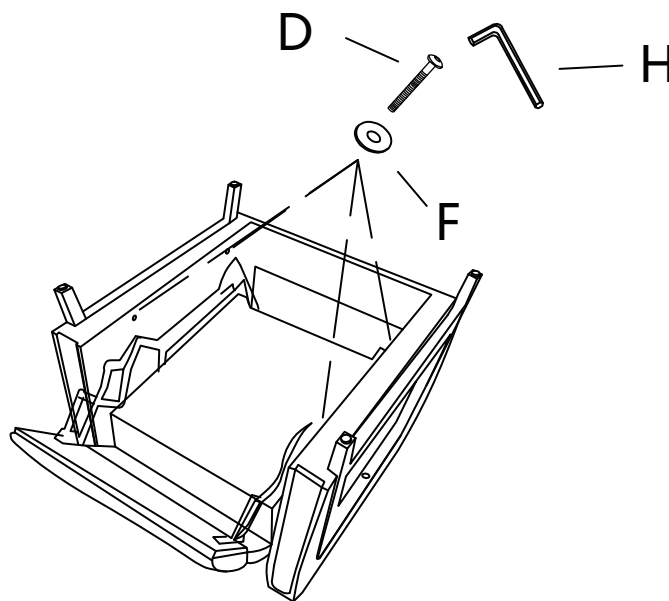

Assembly Instruction

STEP 3

Insert the B backrest into the rear of the A seat.

